



T&S BRASS AND BRONZE WORKS, INC.

2 Saddleback Cove / P.O. Box 1088
Travelers Rest, SC 29690

Model No.

B-0831-WA

Item No.

Travelers Rest, SC: 800-476-4103 • Simi Valley, CA: 800-423-0150 • Fax: 864-834-3518 • www.tsbrass.com



ADA Compliant

This Space for Architect/Engineer Approval

Job Name _____ Date _____

Model Specified _____ Quantity _____

Customer/Wholesaler _____

Contractor _____

Architect/Engineer _____

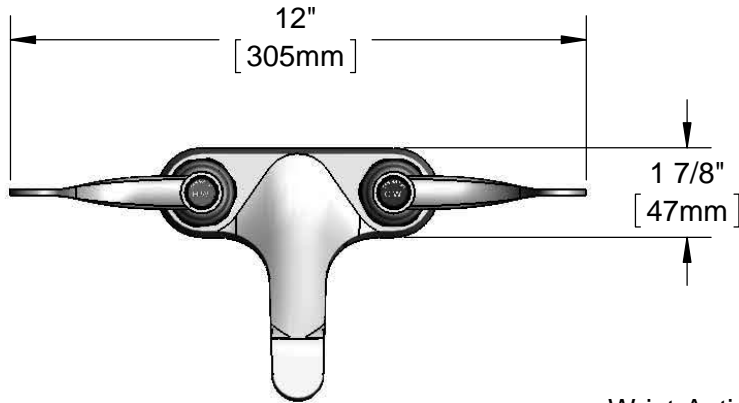

Wrist-Action Metering Cartridges & 4" Wrist Action Handles w/ Color Coded Indexes

B-0199-03
2.2 GPM
Aerator

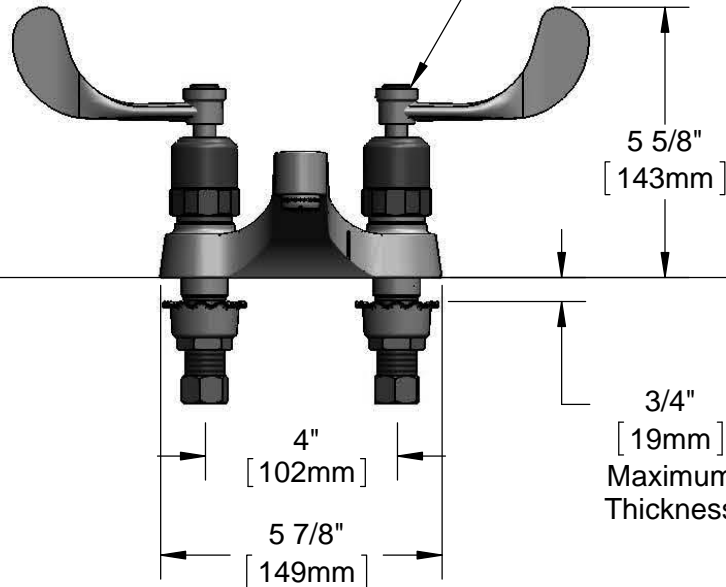

Mounting Surface

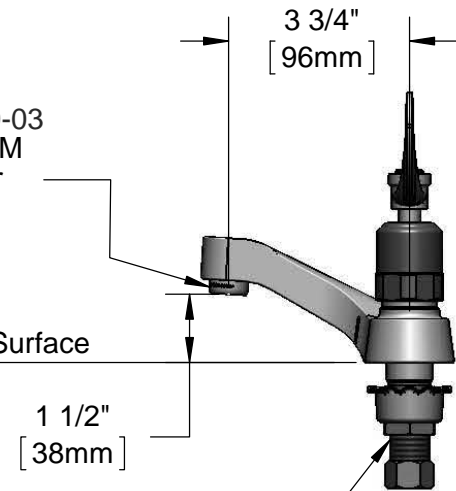

1/2" NPSM
Male Shanks w/
Coupling Nuts

Rough-In Requirement:
(2) ϕ 1 1/8" [29mm] Mounting Holes

Product Specifications:

4" Centerset Metering Mixing Faucet, Metering Cartridges, 4" Wrist Action Handles & 2.2 GPM Aerator & 1/2" NPSM Male Shanks

Product Compliance:

ASME A112.18.1 / CSA B125.1
NSF 61 - Section 9
NSF 372 (Low Lead Content)
ANSI A117.1 (ADA)



T&S BRASS AND BRONZE WORKS, INC.
 2 Saddleback Cove / P.O. Box 1088
 Travelers Rest, SC 29690

Model No.
B-0831-WA
 Item No.

Travelers Rest, SC: 800-476-4103 • Simi Valley, CA: 800-423-0150 • Fax: 864-834-3518 • www.tsbrass.com

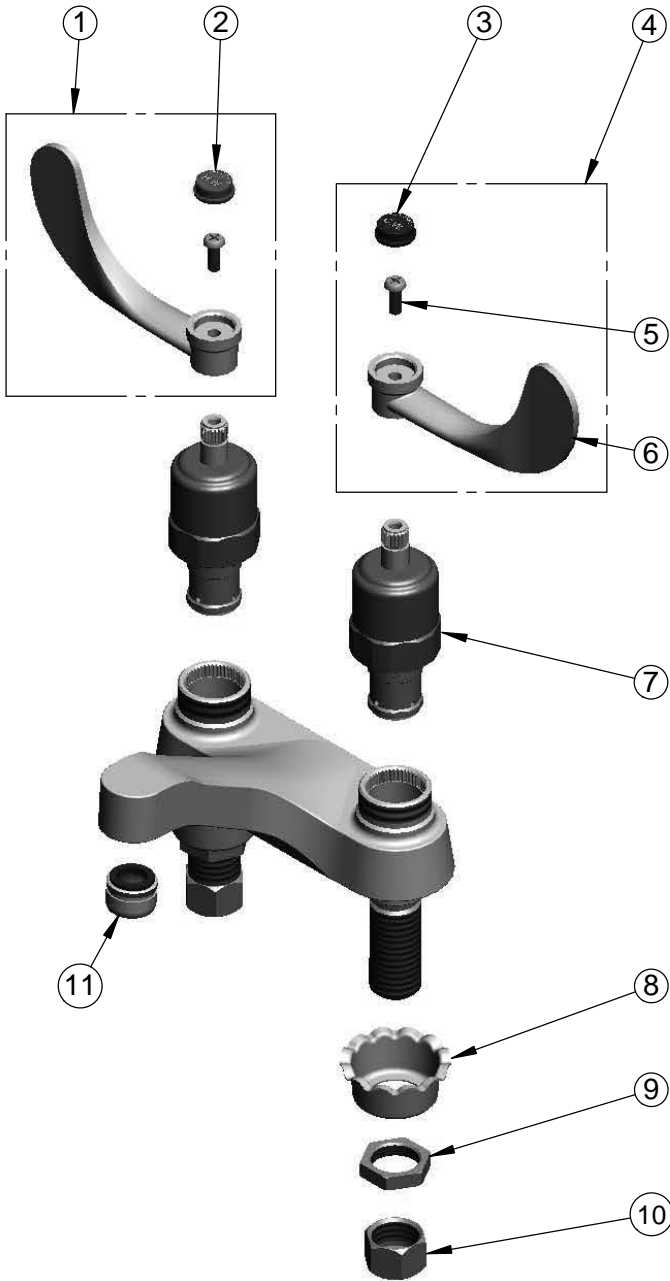

ITEM NO.	SALES NO.	DESCRIPTION
1	B-WH4H	4" Wrist Action Handle, Screw & Hot Index
2	001194-45	Red Index - HW
3	001686-45	Blue Index - CW
4	B-WH4C	4" Wrist Action Handle, Screw & Cold Index
5	000925-45	Lab Handle Screw
6	B-WH4	4" Wrist Action Handle
7	012449-40	Wrist-Action Metering Cartridge
8	001000-45	Rosette Washer
9	002954-45	Shank Lock Nut
10	000958-20	Coupling Nut
11	B-0199-03	2.2 GPM Aerator

Product Specifications:
 4" Centerset Metering Mixing Faucet, Metering Cartridges, 4" Wrist Action Handles & 2.2 GPM Aerator & 1/2" NPSM Male Shanks

Product Compliance:
 ASME A112.18.1 / CSA B125.1
 NSF 61 - Section 9
 NSF 372 (Low Lead Content)
 ANSI A117.1 (ADA)