



T&S BRASS AND BRONZE WORKS, INC.
 2 Saddleback Cove / P.O. Box 1088
 Travelers Rest, SC 29690

Model No.
B-0871-CR

Item No.

Travelers Rest, SC: 800-476-4103 • Simi Valley, CA: 800-423-0150 • Fax: 864-834-3518 • www.tsbrass.com



ADA Compliant

This Space for Architect/Engineer Approval

Job Name _____ Date _____

Model Specified _____ Quantity _____

Customer/Wholesaler _____

Contractor _____

Architect/Engineer _____

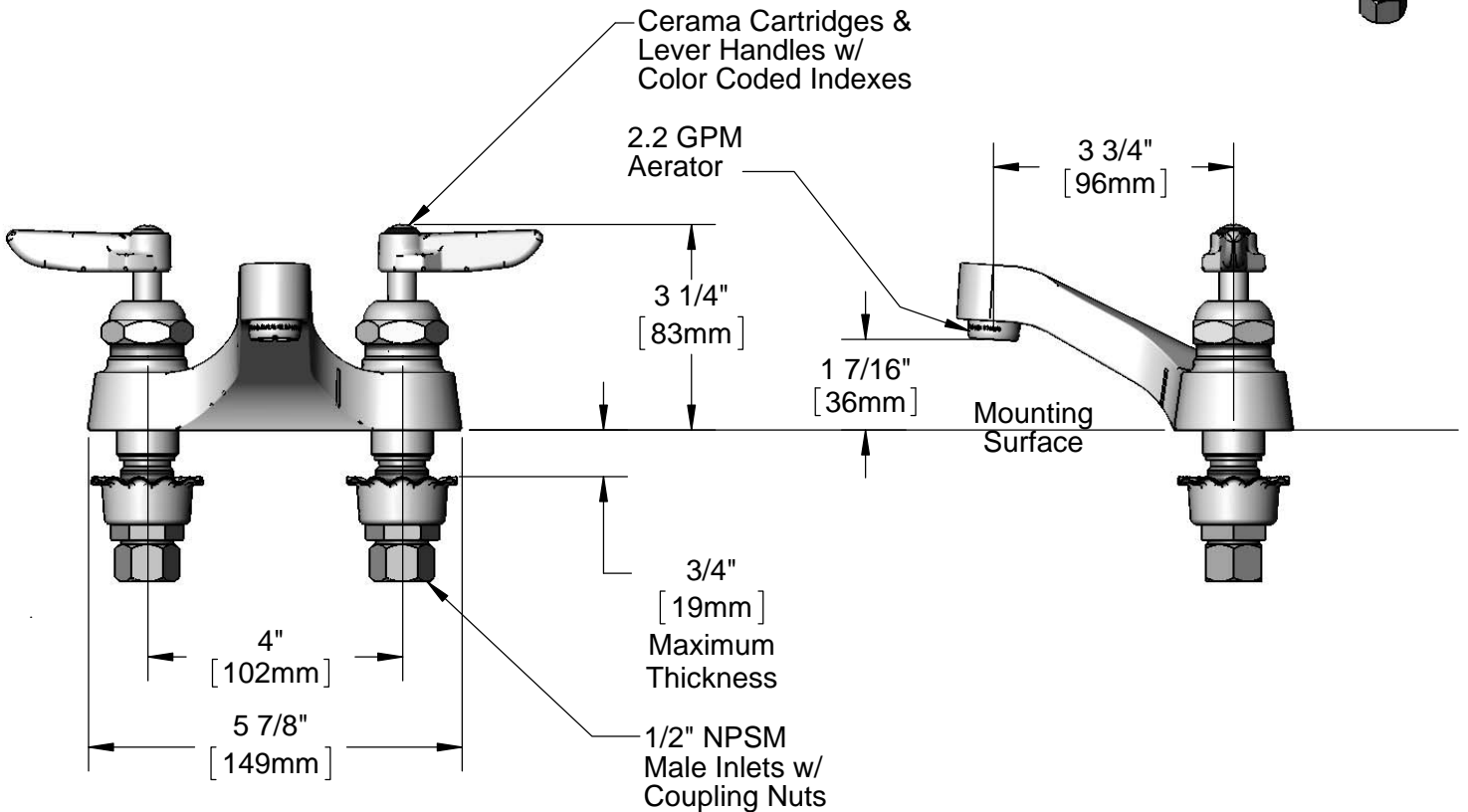
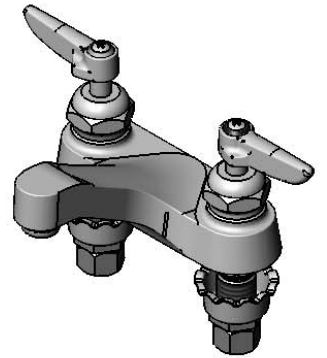
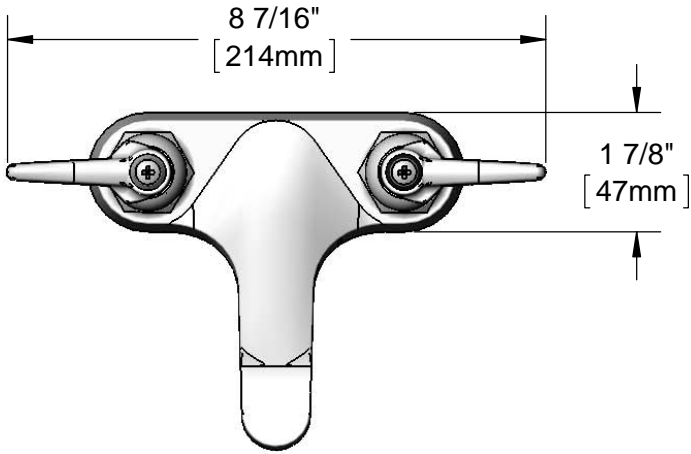

Rough-In Requirement:
 (2) ϕ 1 1/8" [29mm] Mounting Holes

Product Specifications:
 4" Centerset Deck Mount Faucet, Cerama Cartridges, Lever Handles,
 2.2 GPM Aerator & 1/2" NPSM Male Inlets w/ Coupling Nuts

Product Compliance:
 ASME A112.18.1 / CSA B125.1
 NSF 61 - Section 9
 NSF 372 (Low Lead Content)
 ANSI A117.1 (ADA)



T&S BRASS AND BRONZE WORKS, INC.
 2 Saddleback Cove / P.O. Box 1088
 Travelers Rest, SC 29690

Model No.
B-0871-CR
 Item No.

Travelers Rest, SC: 800-476-4103 • Simi Valley, CA: 800-423-0150 • Fax: 864-834-3518 • www.tsbrass.com

ITEM NO.	SALES NO.	DESCRIPTION
1	B-0199-03	2.2 GPM Aerator, 13/16-27 UN Male
2	012444-25	Cerama Cartridge, RTC w/ Handle, Index & Screw
3	011278-25	Cerama Cartridge, RTC
4	001661-45	Red Index-HW
5	000922-45	Lever Handle Screw
6	001660-45	Blue Index-CW
7	001638-45	Lever Handle
8	011279-25	Cerama Cartridge, LTC
9	012445-25	Cerama Cartridge, LTC w/ Handle, Index & Screw
10	001000-45	Rosette Washer
11	002954-45	Shank Lock Nut
12	000958-20	Coupling Nut

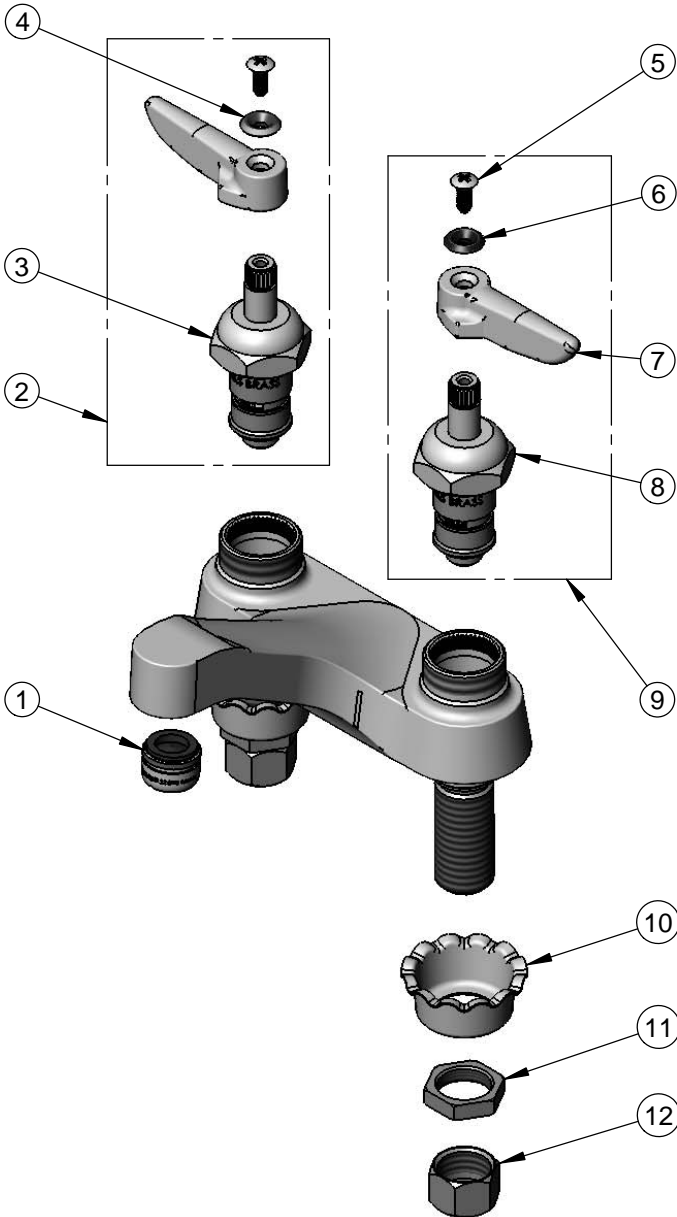

Product Specifications:
 4" Centerset Deck Mount Faucet, Cerama Cartridges, Lever Handles,
 2.2 GPM Aerator & 1/2" NPSM Male Inlets w/ Coupling Nuts

Product Compliance:
 ASME A112.18.1 / CSA B125.1
 NSF 61 - Section 9
 NSF 372 (Low Lead Content)
 ANSI A117.1 (ADA)