

INSTRUCTIONS

CU SERIES COMPACT UNDERCOUNTER FOOD STORAGE CABINETS

MODEL

<i>CU27</i>	<i>ML-111169</i>	
<i>CUF27</i>	<i>ML-111170</i>	
<i>CUS27</i>	<i>ML-111171</i>	
<i>CU48</i>	<i>ML-111175</i>	<i>ML-111185</i>
<i>CUF48</i>	<i>ML-111176</i>	<i>ML-111186</i>
<i>CUS48</i>	<i>ML-111177</i>	<i>ML-111187</i>
<i>CU60</i>	<i>ML-111178</i>	<i>ML-111188</i>
<i>CUF60</i>	<i>ML-111179</i>	<i>ML-111189</i>
<i>CUS60</i>	<i>ML-111180</i>	<i>ML-111190</i>



701 S. RIDGE AVENUE
TROY, OHIO 45374-0001

937 332-3000

www.hobartcorp.com

FORM 34057 Rev. C (Jan. 2002)

SANDWICH PREP TABLES



MODEL CUS27



MODEL CUS48



MODEL CUS60

REFRIGERATOR / FROZEN FOOD STORAGE CABINETS



MODELS CU27 or CUF27



MODELS CU48 or CUF48



MODELS CU60 or CUF60

Installation, Operation and Care of CU SERIES COMPACT UNDERCOUNTER FOOD STORAGE CABINETS

SAVE THESE INSTRUCTIONS

GENERAL

CU Series are 27", 48" or 60" wide refrigerator, frozen food or sandwich preparation type food storage cabinets. The cabinets measure 29½" high, exclusive of legs, casters or cabinet base. Cabinet walls are insulated with urethane foam. CU Series condensing units are front breathing, ventilate from the bottom at the front of the cabinet and cannot be enclosed underneath. CU Series refrigerator and sandwich prep compressors utilize R134A refrigerant. CUF27 frozen food cabinet uses R134A; CUF48 and CUF60 frozen food cabinets use R404A.

Cabinet interior is DuraFinish™ aluminum. Exterior is stainless steel, on front, sides and top. The exterior back and bottom are galvanized steel.

Cabinet doors have spring-loaded hinges that stay open at 105° and self-close below 90°. Doors can be reverse-hinged at the installation site. Vinyl door gaskets with magnetic seal are easy to clean.

CU Series wire shelves are supported by adjustable clips and pilasters.

CU Series cabinets are self-contained and are equipped with cord and plug, standard.

Options include the following: 6" Legs, a variety of Casters, a 6" high Front Ventilated Utility Base (27" wide only), Field-Installed Stainless Steel Worktop with Backsplash, Field-Installed Stainless Steel Worktop with Backsplash and Removable Polyethylene Worktop, Stack Kit (CU27 or CUF27 only), additional Shelves, Overshelves and Stainless Steel Clad Back. Some options are not available on all models.

INSTALLATION

Prior to installation, test the electrical service to assure that it agrees with the specifications on the machine data plate located on the upper left wall inside the cabinet.

UNPACKING

Immediately after unpacking, check for possible shipping damage. If the refrigerator is found to be damaged, save the packaging material and contact the carrier within 15 days of delivery.

Do not lay the refrigerator on its back, front or sides.

LOCATION

Condenser performance is dependent on adequate ventilation for cooling purposes. Adequate clearance **MUST** be provided for the ventilator locations underneath. There are no clearance requirements for sides, rear or top. If installing over a 27" wide utility base, provide adequate clearance at rear of unit to clean the condenser coil (refer to pages 6 and 15).

NOTE: Do not install the cabinet without legs, casters or front-ventilated utility base.

LEGS OR CASTERS

WARNING: THE CABINET MUST BE BLOCKED AND STABLE BEFORE INSTALLING LEGS OR CASTERS.

Raise up and block the cabinet a minimum of 7" from the floor and thread the legs into the Threaded Holes on the bottom of the cabinet (Fig. 1). Thread optional casters into the Threaded Holes on the bottom of the cabinet in the same way (Fig. 2). Casters with brake should be installed at the front. Tighten securely using octagon-shaped head of Bolt underneath — not round flange on top.

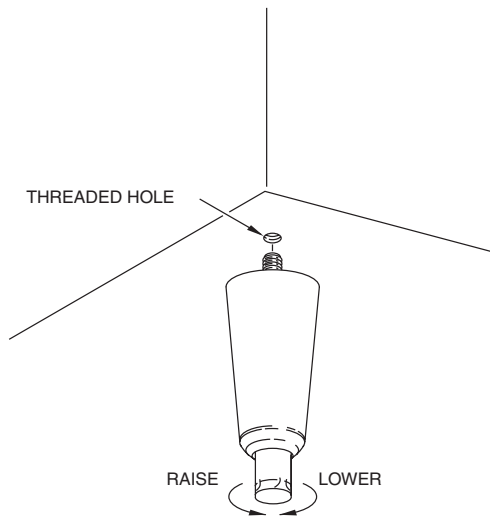

Fig. 1

PL-56125

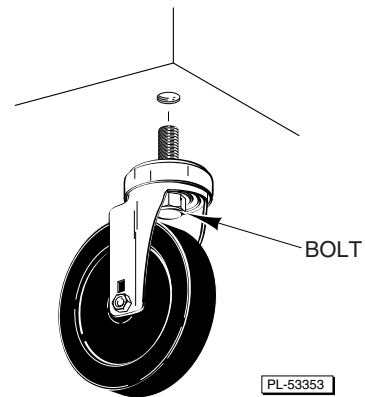

Fig. 2

LEVELING

Level the cabinet using a spirit level or pan of water in the bottom of the cabinet. On units with legs, turn the adjustable feet in or out to level the cabinet side-to-side and front-to-back. Units with casters should be placed on level floors.

SHELVES (Fig. 3)

Shelves and Shelf Clips are packed with the unit. For each Shelf, insert four Shelf Clips into the Pilaster Slots at the same height. The Shelf Clips have a small projection on top which holds the Shelf in position and prevents it from slipping forwards. After installing the Shelf Clips on the Pilasters, place the Shelves on the Shelf Clips.

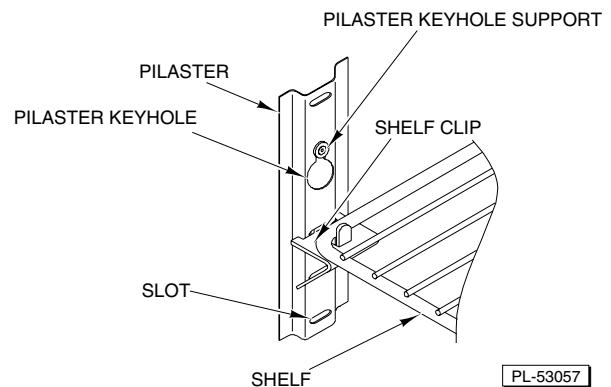

Fig. 3

SANDWICH PREP TOP ASSEMBLY (Figs. 4, 5)

On sandwich prep tables (Fig. 5), the top shelf, cutting board and cover may require assembly.

1. Place the Shelf on top of the rear of the unit. Secure by screwing four threaded Pins through base of Shelf and top of unit (Fig. 4).
2. Install Cutting Board Support. Secure with two threaded Pins and two Bolts per Flange (Fig. 4) (wider units may be equipped with an additional third Pin in the center).
3. Assemble Cutting Board to Cutting Board Support (Pins holding Cutting Board Support fit through holes in Cutting Board when properly aligned — Fig. 4).
4. To install Cover, flex Cover so side Pins fit in holes at lower front corners of Shelf (Fig. 4). Cover pivots up to open.

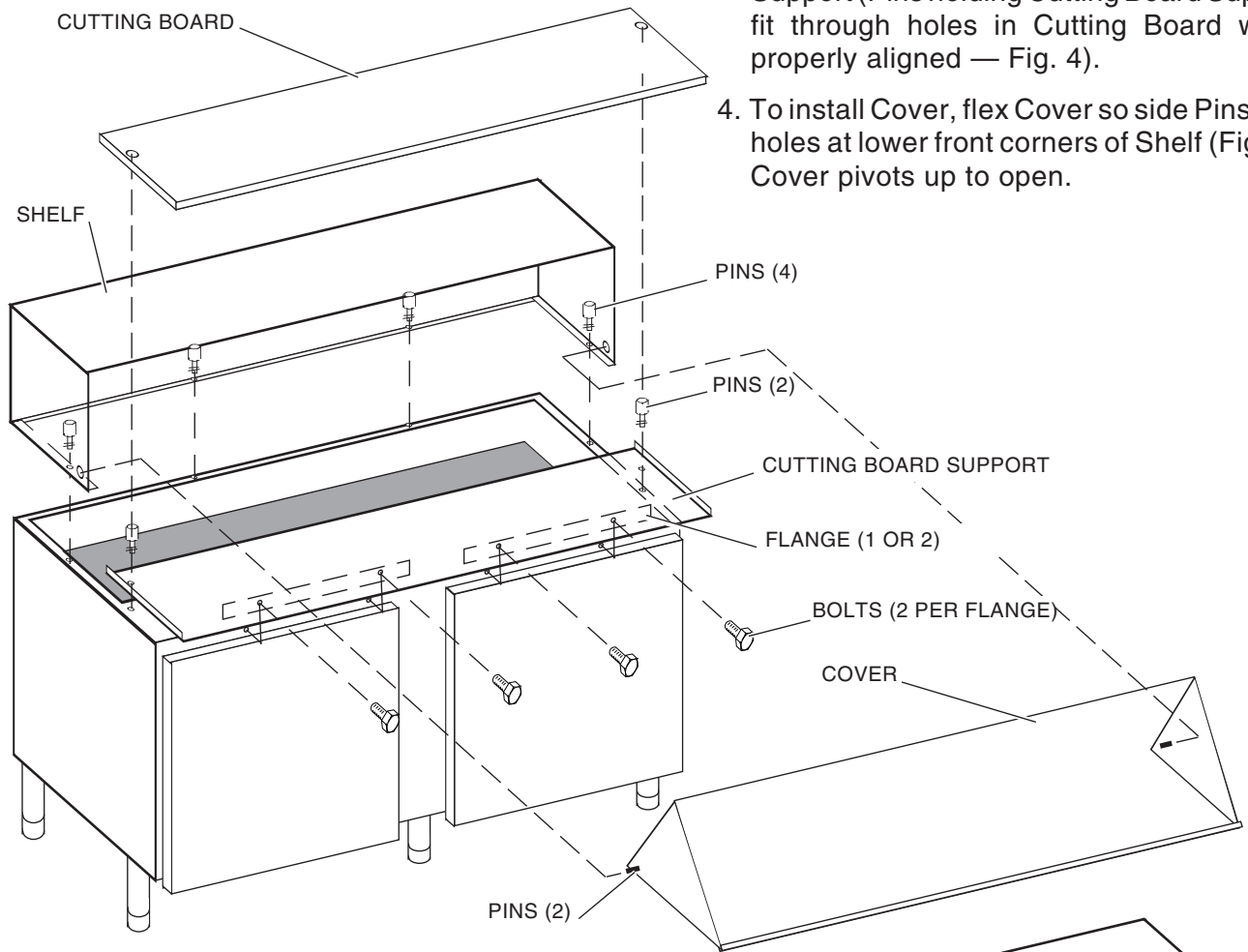

Fig. 4

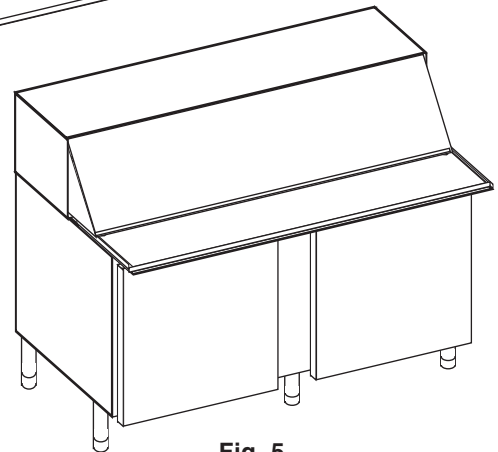

Fig. 5

INSTALLATION OF UTILITY BASE (Optional for CU27, CUF27 & CUS27 Only) — Fig. 6

Provide adequate clearance at the rear of the cabinet for access to the condenser coil for periodic cleaning. Refer to Maintenance (page 15).

1. Place utility base in final installed location. **NOTE:** The front of the utility base must be oriented towards the front. Fastener locations are provided for anchoring utility base to floor, if desired; fasteners are not provided.
2. Place unit on top of utility base so holes underneath are aligned. The plug cord must be routed from the bottom right rear corner of the unit through a slotted hole in the utility base. Assemble the strain relief (provided) around the electric cord and route it through the slotted hole in the utility base.
3. Assemble four $\frac{1}{2}$ – 13 bolts and lockwashers through holes in utility base and into threaded holes in bottom of unit where legs or casters would be installed.
4. Place rear cover on back of utility base so D-slot captures the groove of the strain relief. Attach rear cover with six #8 – 18 self-tapping screws. If floor receptacle is provided underneath utility base for unit to plug into, strain relief will not be used and rear cover should be installed upside-down so D-slot is covered.
5. Install front grill on front of stacking base with eight #8 – 18 self-tapping screws.
6. Apply a bead of NSF approved silicone sealant around the bottom of the utility base.

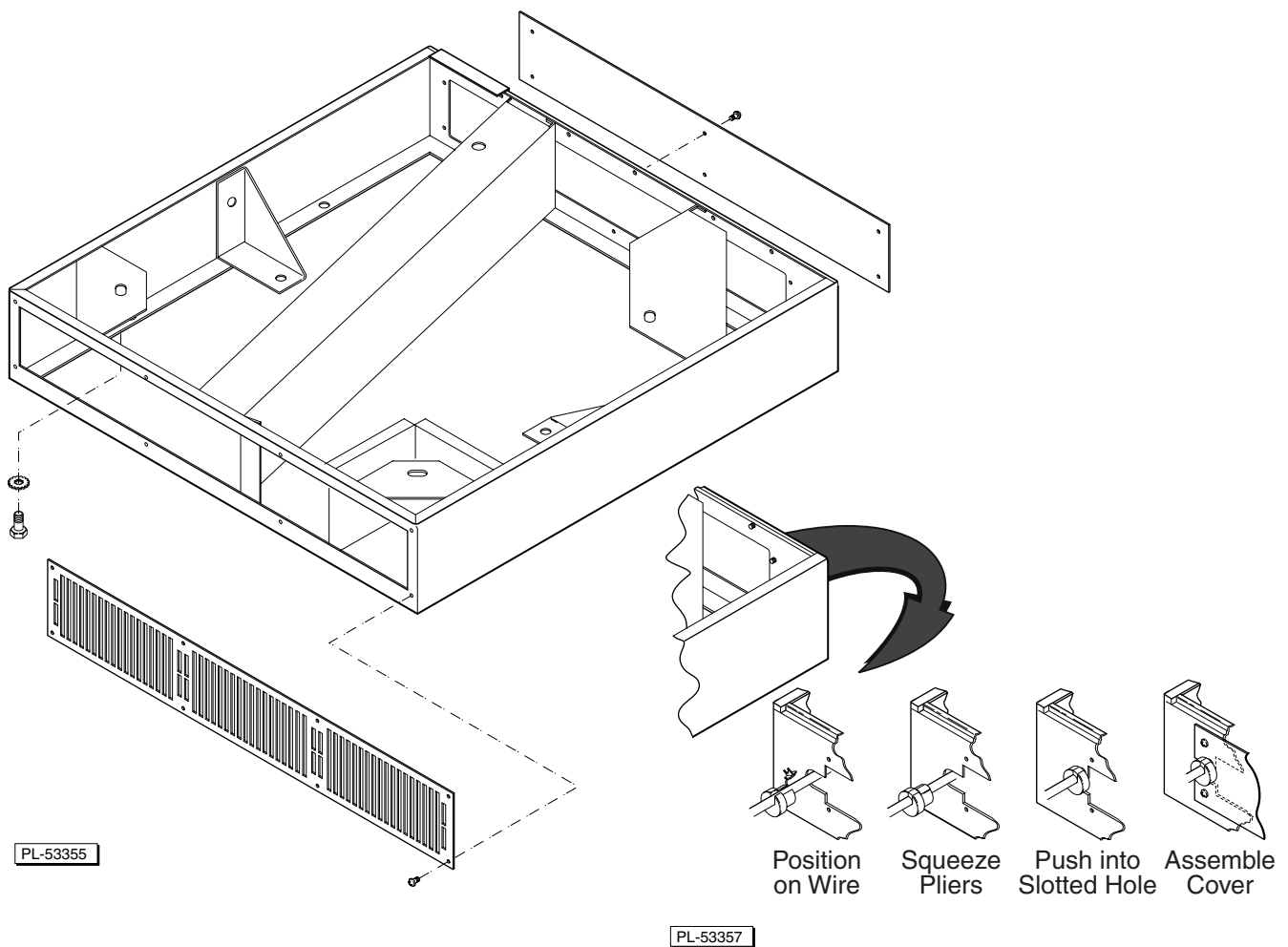
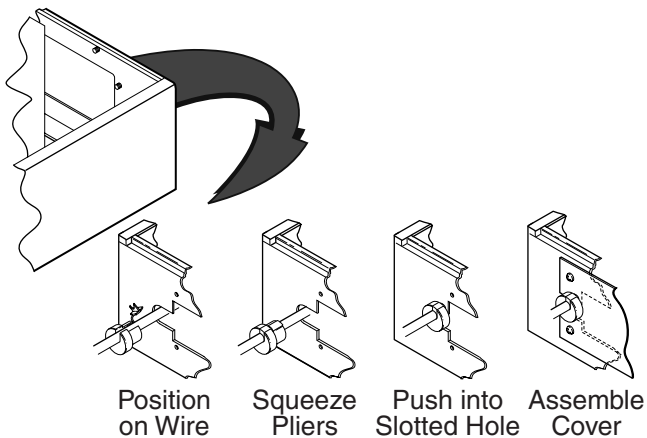
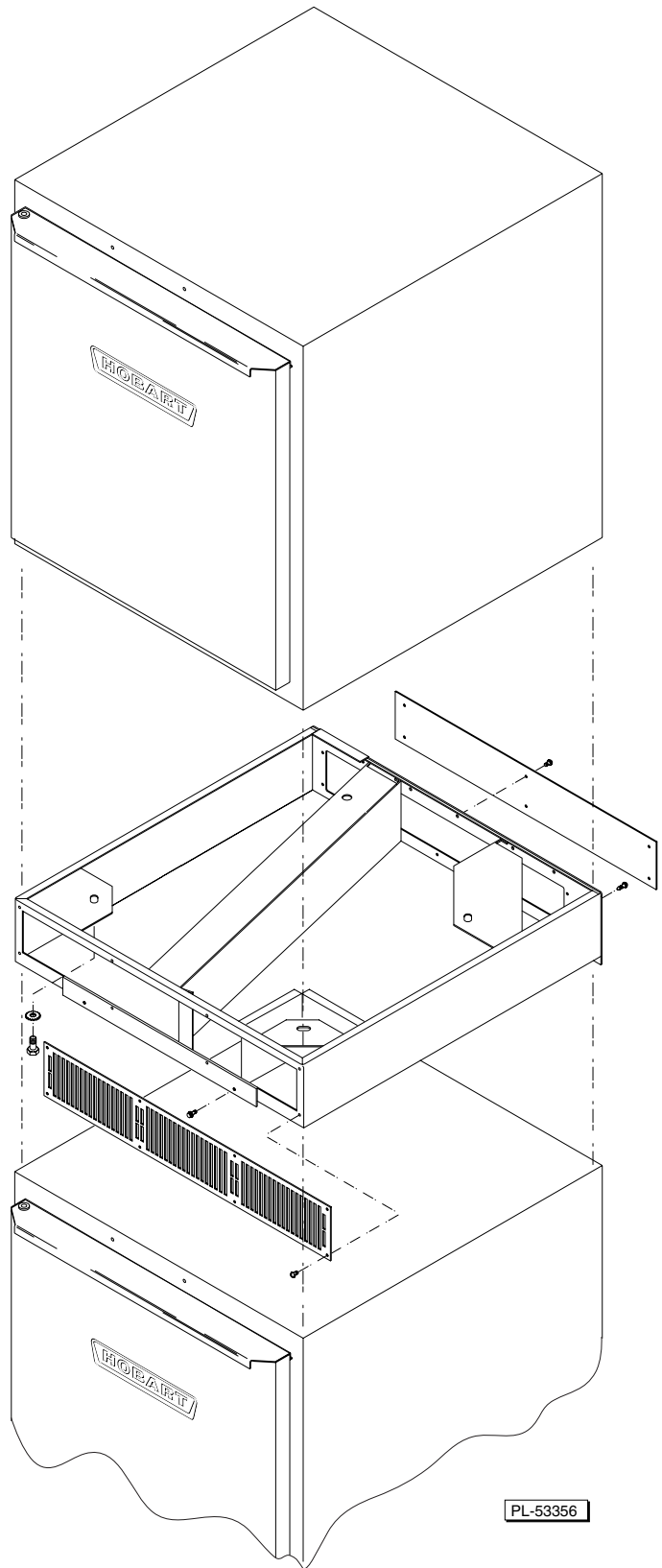

Fig. 6

INSTALLATION OF STACKING BASE (Optional for CU27, CUF27 Only) — Fig. 7

1. Install legs, casters or utility base on bottom unit following instructions elsewhere in this manual. Place bottom unit near final installed location leaving access to rear for further assembly.
2. Place stacking base on top of bottom unit.
NOTE: The front of the stacking base must be oriented towards the front.
3. Assemble two $\frac{1}{4}$ – 20 x $\frac{5}{8}$ " screws through front mounting flange of stacking base into the threaded holes in the front of the top edge of the bottom unit. Assemble five #10 – 16 x $\frac{1}{2}$ " screws through rear flange of the stacking base into the upper rear of bottom unit.
4. Place upper unit on top of stacking base so holes underneath are aligned.
5. Assemble four $\frac{1}{2}$ – 13 bolts and lockwashers through holes in stacking base into threaded holes in bottom of upper unit where legs or casters would be installed if unit were to sit directly on the floor.
6. The plug cord must be routed from the bottom right rear corner of the upper unit through a slotted hole in the stacking base. Assemble the strain relief (provided) around the electric cord and route it through the slotted hole in the stacking base.
7. Place rear cover on back of stacking base so the D-slot captures the groove of the strain relief. Attach rear cover with six #8 – 18 self-tapping screws.
8. Install front grill on front of stacking base with eight #8 – 18 self-tapping screws.



PL-53357

Fig. 7

**INSTALLATION OF THE STAINLESS STEEL WORKTOP (Optional for CU and CUF models)
WITH OR WITHOUT OPTIONAL POLYETHYLENE CUTTING BOARD — Fig. 8**

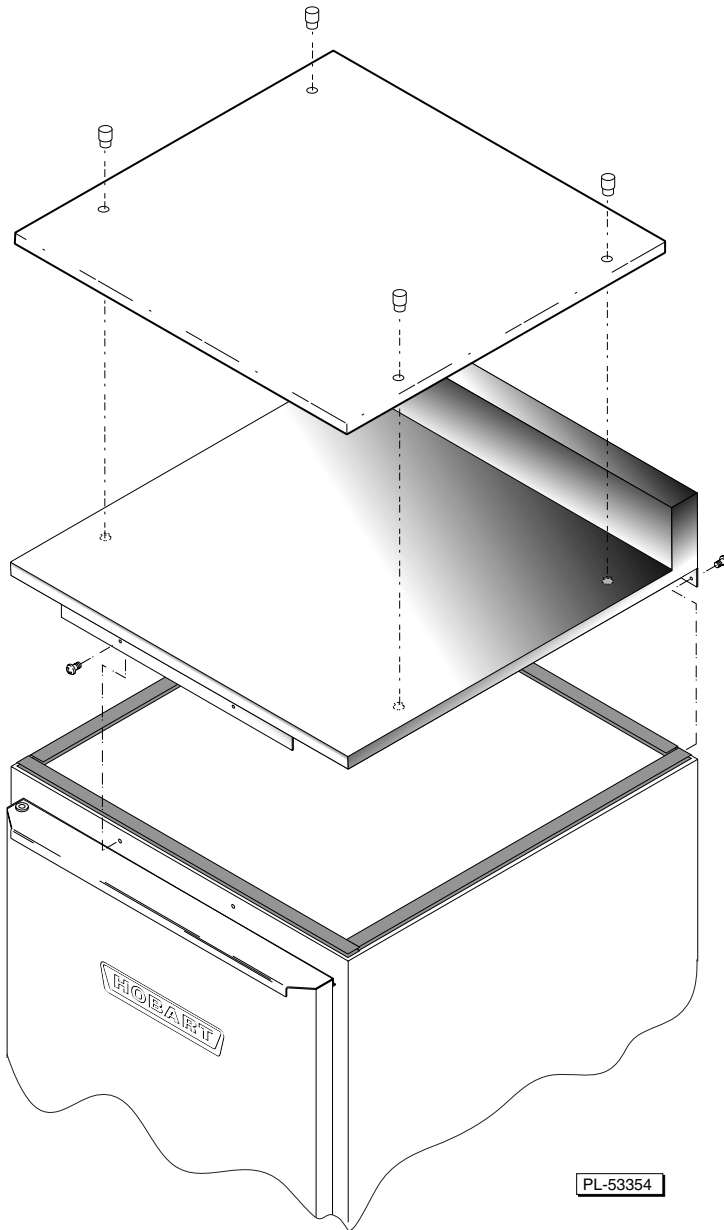

1. Peel off backing and install foam tape (provided) around entire perimeter of the top of the unit.
2. A flange is assembled underneath at the front of the countertop. This flange has two screw holes for 27" cabinets, five screw holes for 48" or 60" wide cabinets. Screw the $\frac{1}{4}$ – 20 x $\frac{5}{8}$ " screws (provided) through the holes in this front flange into the threaded holes in the front of the top edge of the unit.
3. Using the five #10 – 16 x $\frac{1}{2}$ " screws for 27" wide cabinets or eight screws for 48" or 60" wide cabinets provided, screw the bottom of the rear cover plate to the upper rear of the cabinet.
4. If the optional polyethylene cutting board top is provided, there are four threaded pins which screw into the four threaded holes in the worktop. The four holes in the polyethylene cutting board top fit around the heads of the four pins.

Fig. 8

INSTALLATION OF SINGLE OVERSHELF (Accessory for CU and CUF models) — Fig. 9

Parts

Single Overshelf	433935-1 Single Overshelf Accy. for Models CU27, CUF27 27 Inches Wide		433935-2 Single Overshelf Accy. for Models CU48, CUF48 48 Inches Wide		433935-3 Single Overshelf Accy. for Models CU60, CUF60 60 Inches Wide	
	6	SD 032-31 Phillips Head SST Screw #8-18 x 3/8"		6		SD 032-31 Phillips Head SST Screw #8-18 x 3/8"
1	433888-1 Overshelf 27" wide x 10" high x 9 ⁵ / ₈ " deep		1		434002-1 Overshelf 48" wide x 10" high x 9 ⁵ / ₈ " deep	
			1		434003-1 Overshelf 60" wide x 10" high x 9 ⁵ / ₈ " deep	

1. Remove the two screws at the top rear corners of refrigerator or freezer unit. These screws can be reused in the same locations or you can use two new #8 –18 x 3/8" screws from the kit.
2. Place overshelf 10¹/₄" above top rear of top or refrigerator or freezer and support with 10¹/₄" thickness of something suitable.
3. Install four #8 –18 x 3/8" screws from the kit through the overshelf's holes into the rear of the refrigerator or freezer unit.
4. Locate the holes in the sides of the overshelf support. Drill a 1/8" diameter hole a maximum of 1/4" deep through the side of the refrigerator or freezer.
5. Install one #8 –18 x 3/8" screw through each side hole of the overshelf into the newly drilled holes in the sides of the refrigerator or freezer unit.

NOTE: For cleaning, the overshelf may be removed with a screwdriver; reassemble as shown.

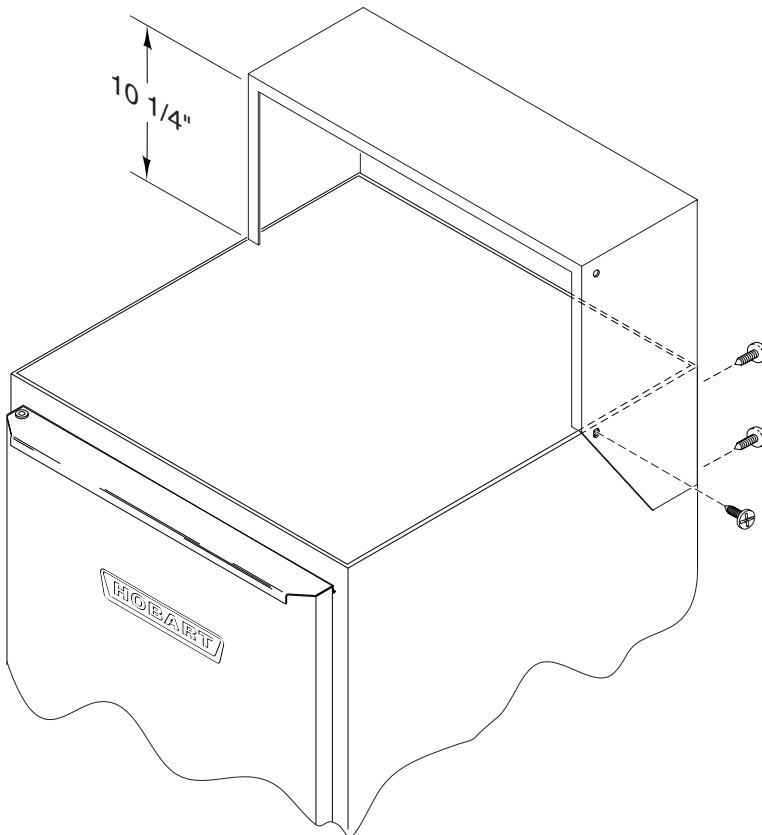

PL-53620

Fig. 9

INSTALLATION OF DOUBLE OVERSHELF (Accessory for CU and CUF models) — Fig. 10

Parts

Double Overshelf	433936-1 Double Overshelf Accy. for Models CU27, CUF27 27 Inches Wide		433936-2 Double Overshelf Accy. for Models CU48, CUF48 48 Inches Wide		433936-3 Double Overshelf Accy. for Models CU60, CUF60 60 Inches Wide	
	6	SD 032-31 Phillips Head SST Screw #8-18 x 3/8"	6	SD 032-31 Phillips Head SST Screw #8-18 x 3/8"	6	SD 032-31 Phillips Head SST Screw #8-18 x 3/8"
	1	433888-1 Lower Overshelf 27" wide x 10" high x 9 ⁵ / ₈ " deep	1	434002-1 Lower Overshelf 48" wide x 10" high x 9 ⁵ / ₈ " deep	1	434003-1 Lower Overshelf 60" wide x 10" high x 9 ⁵ / ₈ " deep
	6	SA 021-36 Phillips Head SST Screw #10-24 x 3/8"	6	SA 021-36 Phillips Head SST Screw #10-24 x 3/8"	6	SA 021-36 Phillips Head SST Screw #10-24 x 3/8"
	6	NS 025-01 SST Acorn Nut #10-24	6	NS 025-01 SST Acorn Nut #10-24	6	NS 025-01 SST Acorn Nut #10-24
	1	433888-2 Upper Overshelf 27" wide x 10" high x 9 ⁵ / ₈ " deep	1	434002-2 Upper Overshelf 48" wide x 10" high x 9 ⁵ / ₈ " deep	1	434003-2 Upper Overshelf 60" wide x 10" high x 9 ⁵ / ₈ " deep

1. Install the lower shelf as described in INSTALLATION OF SINGLE OVERSHELF, page 9.
2. Place upper overshelf 10¹/₄" above top rear of single (lower) overshelf and support with 10¹/₄" thickness of something suitable.
3. Install two upper and two lower #10 – 24 x 3/8" stainless steel machine screws through rear of upper and lower shelves, and secure them with #10 – 24 acorn nuts on the inside.

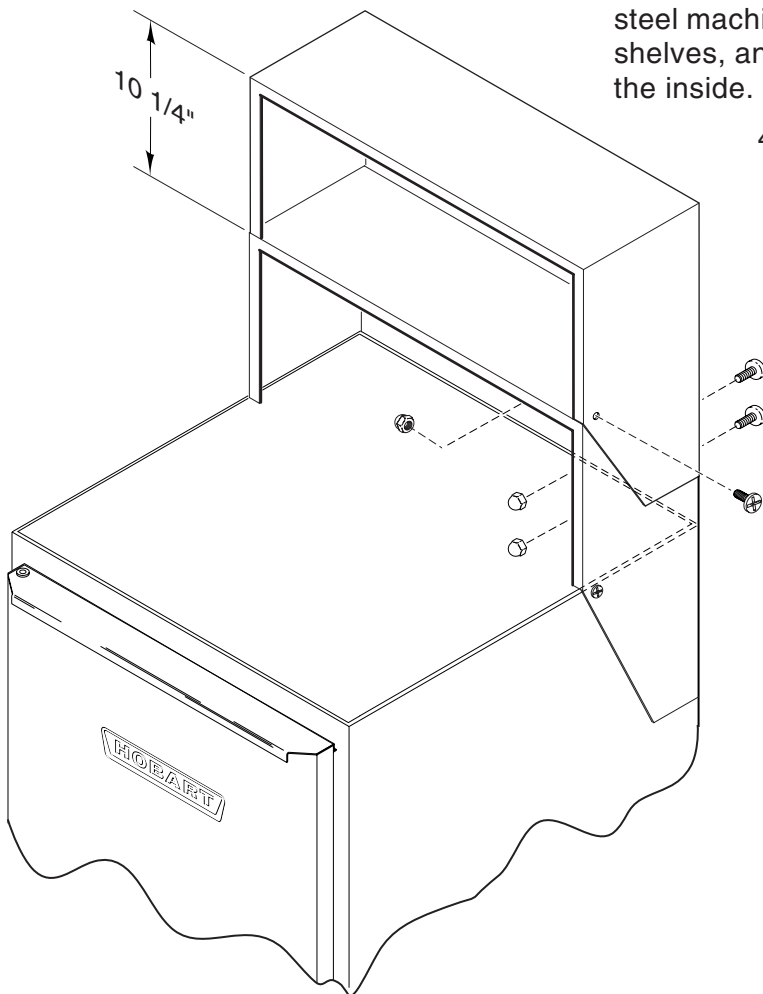

4. Install one #10 – 24 x 3/8" stainless steel machine screw through each side of upper and lower shelves, and secure them with #10 – 24 acorn nuts on the inside.

NOTE: For cleaning, the double overshelf may be removed with a screwdriver; reassemble as shown.

PL-53619

Fig. 10

ELECTRICAL CONNECTIONS

Line voltage supplied to the condensing unit junction box must not be affected by the operation of other electrical equipment. Refer to the wiring diagram shipped with the unit.

Cord Connected Units

WARNING: THIS MACHINE IS PROVIDED WITH A THREE-PRONG GROUNDING PLUG. THE OUTLET TO WHICH THIS PLUG IS CONNECTED MUST BE PROPERLY GROUNDED. IF THE RECEPTACLE IS NOT THE PROPER GROUNDING TYPE, CONTACT AN ELECTRICIAN.

PRESTART CHECKS

The compressor must float freely before connecting to electrical power. The compressor motor is provided with rubber vibration isolator mounts (no springs). No bolts need to be loosened. Check all exposed refrigeration lines to make sure they are not dented or kinked. Check for tubing shifts due to shipping that would cause operating noise, wear or leaks. Check that condenser fan rotates freely.

TEMPERATURE CONTROL — The temperature is set at the factory but local conditions may necessitate slight adjustment.

The temperature control shown in Fig. 11 is located on the right side of the evaporator housing. To adjust, turn the adjustment screw with a screwdriver a small amount at a time; turning clockwise lowers the temperature. An OFF position is fully counterclockwise and interrupts power to the compressor and condenser fan only, not the entire refrigerator.

On earlier 48" and 60" wide models, the temperature control shown in Fig. 12 was mounted inside the cabinet. To adjust, turn adjustment screw with a screwdriver a small amount at a time; turning counterclockwise lowers the temperature. There is no OFF position. The thermostat dial has dual Celsius and Fahrenheit temperature graduations. The dial is marked – 30°F to 90°F.

DEFROST TIMER — Frozen food storage cabinets are equipped with a defrost timer (Fig. 13) that provides a 20 minute defrost cycle every 6 hours (four defrost cycles per day). This control can be adjusted to set when the next defrost cycle will start. To adjust the defrost time control, use a coin on the outside slot in the rim of the timer and turn clockwise until the compressor turns off. Continue turning coin clockwise until the compressor restarts. The next defrost cycle will start in about 5 hours 40 minutes. On models CUF27, CUF48 and CUF60, the defrost time control is located on the right side of the evaporator housing, behind the temperature control adjustment screw. On earlier model CUF48 and CUF60, the defrost time control was accessed through a small round opening on the outside rear of the unit.

**TEMPERATURE CONTROL
ALL CURRENT MODELS**

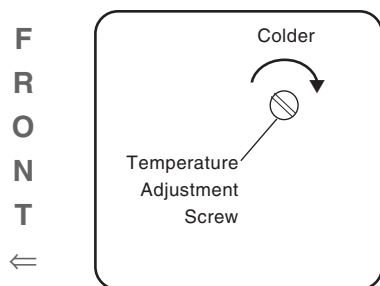

Fig. 11

**TEMPERATURE CONTROL
EARLIER 48" AND 60" WIDE MODELS**

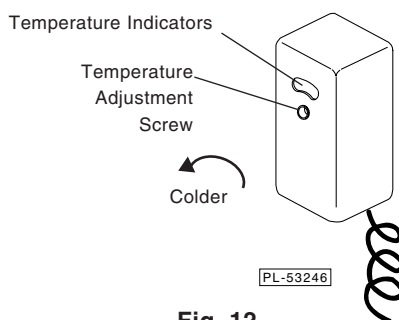

Fig. 12

**DEFROST TIMER
CUF27, CUF48, CUF60 ONLY**

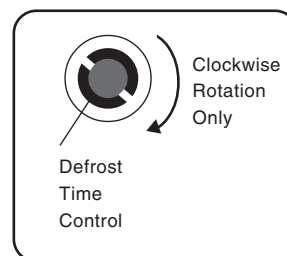

Fig. 13

OPERATIONAL CHECK — The refrigeration system should be checked for proper operation before product is stored in the cabinet.

OPERATION

Thermometer (Fig. 14) is provided on CU series refrigerators.

Allow cabinet to reach normal operating temperature before loading.

CU Series will satisfactorily refrigerate an assorted load of food items. Allow space between articles to permit free air circulation. Do not overload at any one time with warm food products and expect immediate results. A certain amount of time is required to remove heat from items before operating temperatures can be attained. The system is designed for storage of refrigerated or frozen product.

Opening the door will increase the temperature in the cabinet and will require a certain amount of time to recover. Also, after peak service periods or after warm product is loaded, the refrigerator will require a certain amount of time for the temperature to return to the normal operating range.

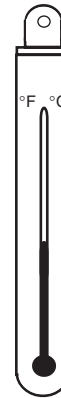

Fig. 14

TO SHUT DOWN FOR AN EXTENDED PERIOD OF TIME

If the refrigerator is not to be used for an extended period of time, disconnect the electrical power supply and open the doors. As soon as the cabinet has warmed up to room temperature, wipe out the interior. Leave the doors open and check again to make sure that no moisture has collected on any parts. To restart refrigerator, follow instructions under PRESTART CHECKS and OPERATION.

Pans and Divider Supports for CUS Models (Fig. 15)

For your convenience, Sandwich Prep models are provided with pans and divider supports in one of several different pan arrangements depending on the width of the unit and the space available. When 18 one-sixth size pans are ordered (on model CUS48 or CUS60), four standard and one wide pan divider supports are provided to achieve appropriate pan separation. When 24 one-sixth size pans are ordered (on model CUS60), six standard and one wide pan divider supports are provided to achieve appropriate pan separation. All other arrangements use all standard width pan divider supports. Pan divider supports hang front to rear.

Pan Arrangements for CUS Models

All pans can be 4" deep. Pan layouts (Fig. 15) show one-sixth size pans (refer to pages 12 – 14).

CUS27 — arranged with 6 pans

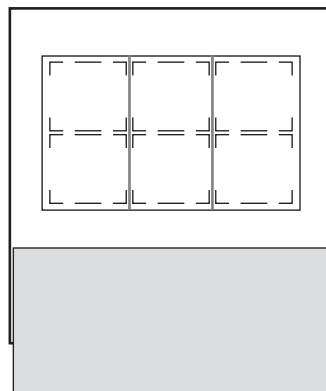

CUS27 — with 9 pans

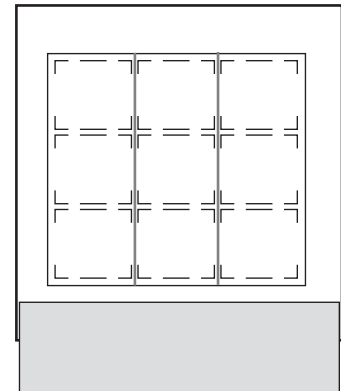
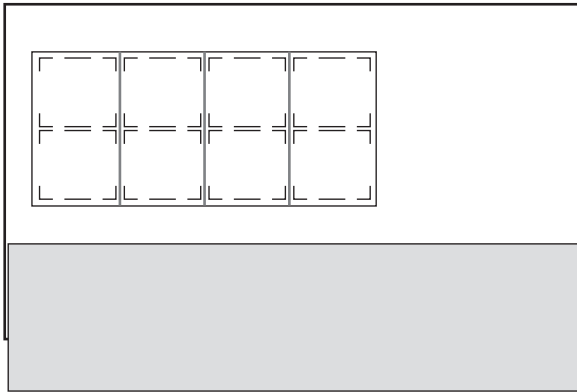
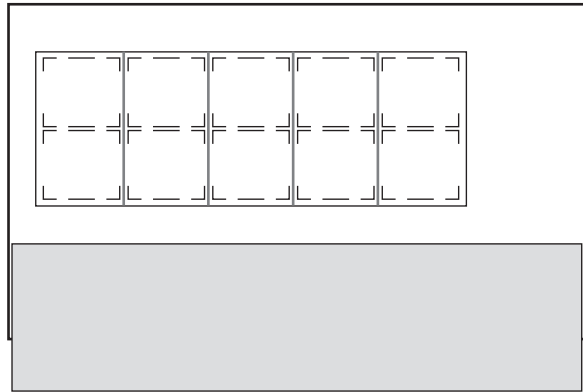

Fig. 15

CUS48 — arrangement with 8 pans



CUS48 — arrangement with 10 pans



CUS48 — arrangement with 12 pans

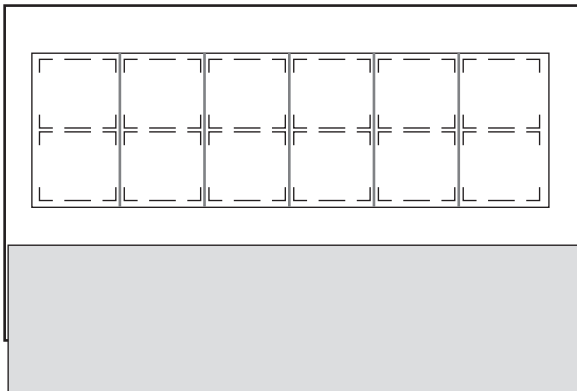

CUS48 — arrangement with 18 pans

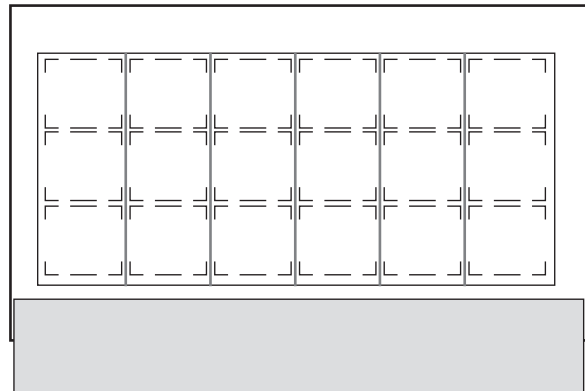

CUS60 — arrangement with 8 pans

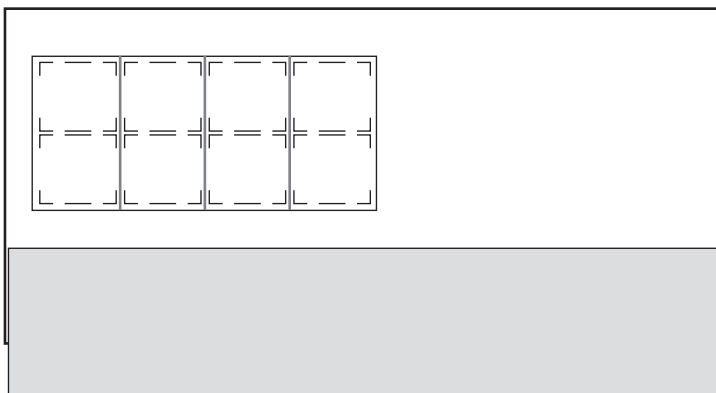
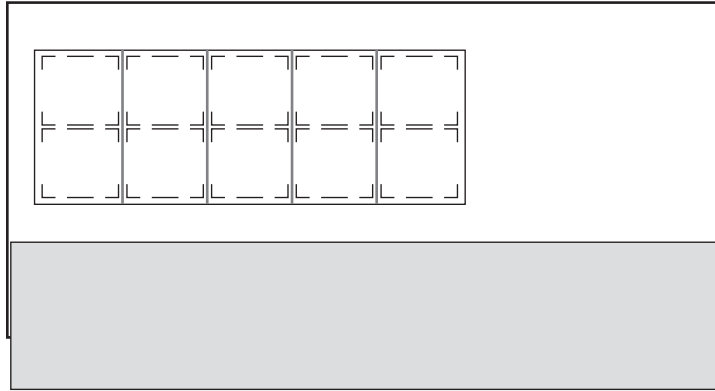
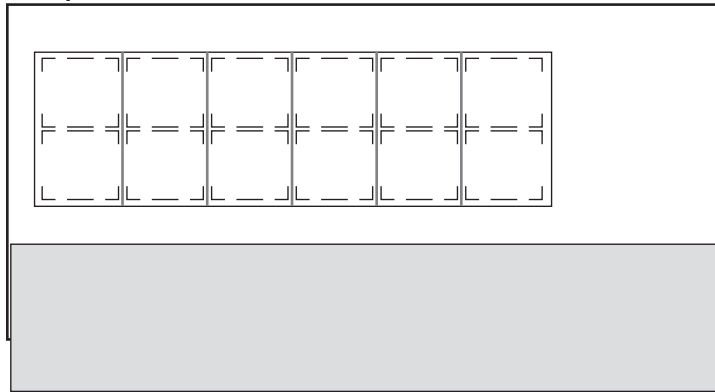

Fig. 15

CUS60 — arrangement with 10 pans



CUS60 — arrangement with 12 pans



CUS60 — arrangement with 18 pans

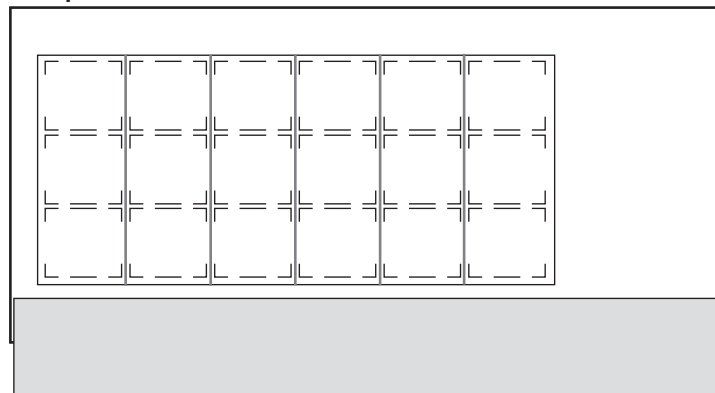

CUS60 — arrangement with 24 pans

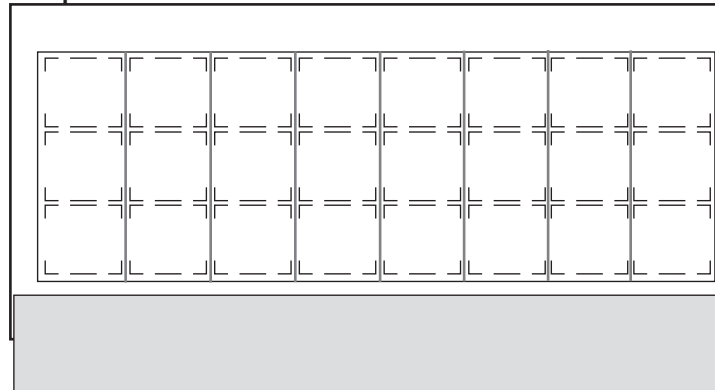

Fig. 15

MAINTENANCE

CLEANING

The cabinet interior is protected with a clear coating. Clean the inside of the cabinet using a soft cloth moistened with warm water. Wipe thoroughly dry. Do not use anything containing grit, abrasive materials, bleach or harsh chemicals. Be cautious with new or improved formulas; use only after being well tested. Rinse thoroughly and dry with a clean soft cloth.

Clean door gaskets and plastic breaker strip around door opening using a solution of mild household liquid dishwashing detergent (such as Palmolive green or Ivory). Do not allow gaskets to come in contact with concentrated cleaners or disinfectants. This can cause premature failure of the gasket material.

Clean stainless steel portions with any recognized stainless steel cleaner.

Remove the shelves, and clean them in a sink.

CONDENSER COIL

WARNING: DISCONNECT ELECTRICAL POWER SUPPLY BEFORE CLEANING ANY PARTS OF THE UNIT.

Check the condenser coil weekly. Air must be able to freely circulate through the condenser. This surface must be kept free of dirt and grease for proper system operation. Remove the lower rear panel on the rear of the equipment cabinet. Carefully clean dirt and lint from the condenser coil using a vacuum cleaner, whisk broom or soft brush; do not use a wire brush. **CAUTION: Do not damage the condenser coil fins.** Replace the lower rear panel. Reconnect electrical power supply.

EVAPORATOR COIL, CONDENSATE LOOP AND CONDENSATE REMOVAL PAN

WARNING: DISCONNECT ELECTRICAL POWER SUPPLY BEFORE CLEANING ANY PARTS OF THE UNIT.

When needed, these components can be flushed with fresh water by a qualified service technician. This should be part of any routine maintenance program and can prolong the life of the equipment.

Condensate removal is provided by evaporation at the lower rear portion of the equipment cabinet and does not need a drain. Periodic cleaning of the condensate removal box may be needed. To access the condensate removal box, remove the lower panel at the rear of the equipment cabinet. Clean the condensate removal box by wiping it out with a clean damp cloth, using care with the condensate loop inside. Replace the lower rear panel. Reconnect electrical power supply.

TROUBLESHOOTING

SYMPTOM

Condensing unit fails to operate.

POSSIBLE CAUSE

Power failure.
Plug loose in receptacle.
Blown fuse or tripped circuit breaker.
If a freezer model is in a defrost cycle, wait 30 minutes and recheck.
Check the Temperature Control (page 11) to make sure it is not OFF.

WARRANTY

The CU series cabinet warranty is for one year. It includes parts, labor and travel during normal working hours in the continental United States. The non-prorated compressor warranty is for an additional four years and does not include labor.

For additional information or to discuss a maintenance program, contact your local Hobart-authorized refrigeration servicer.