



Quality Refrigeration

# CATALOG OF REPLACEMENT PARTS



\* Traulsen's seafood display cabinets were designed for optimal energy efficiency per Department of Energy requirements to be used with ice.

## DISPLAY CASE

TD078HT

4401 BLUE MOUND RD. • FT. WORTH, TX 76106 • 1-800-825-8220



**TABLE OF CONTENTS**

5	CONTROL BOX
7	WELL COMPONENTS
9	FRONT AND SIDE PLEXIGLASS
11	CONDENSING UNIT
13	HEAT EXCHANGE, FANS, AND TUBING
15	DISPLAY CASE BASE

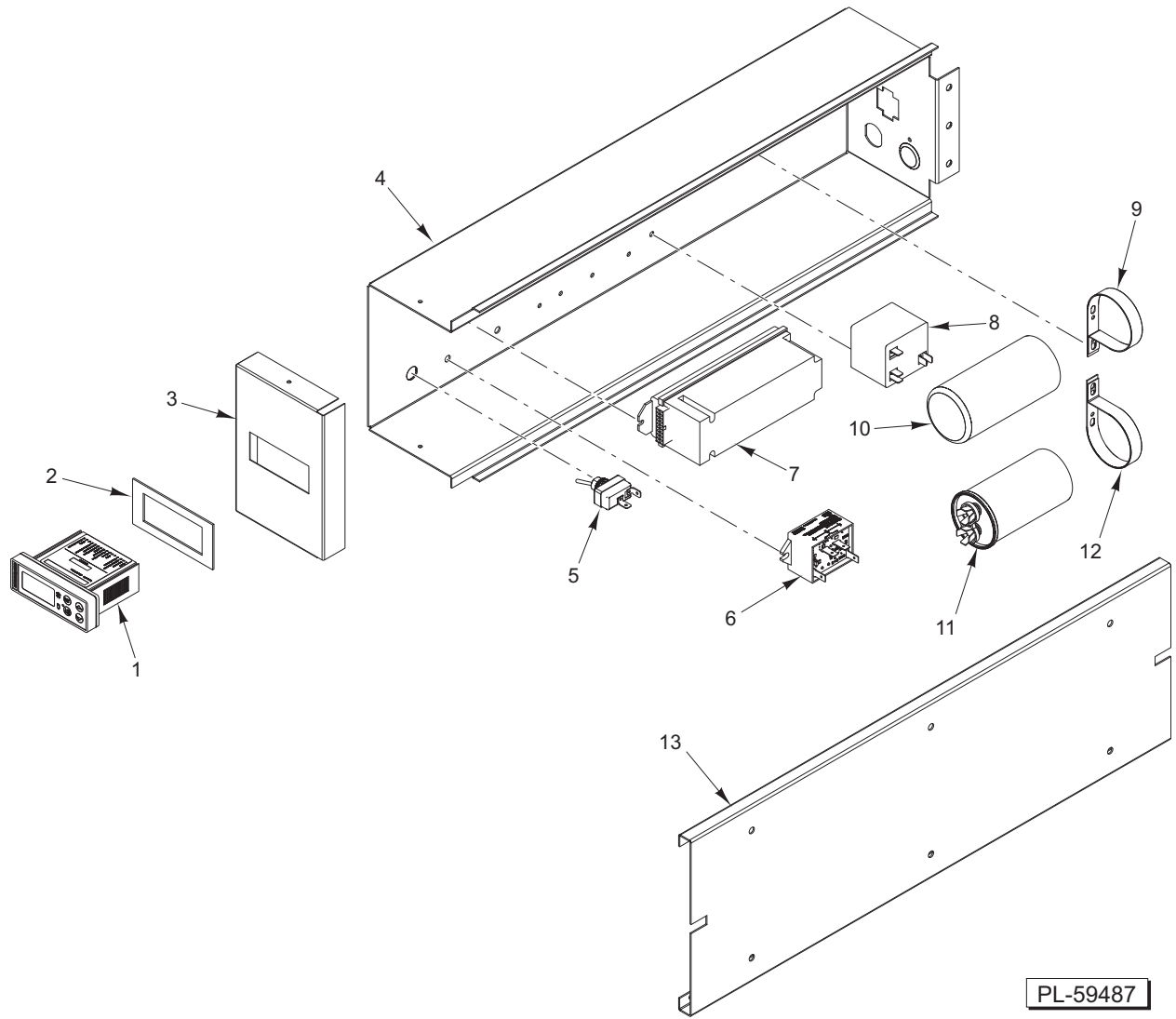

**CONTROL BOX**

**CONTROL BOX**

ILLUS.	PART NO.	NAME OF PART	AMT.
PL-59487			
1	337-60403-00	Control Head.....	1
2	352-60011-00	Gasket – Control Head .....	1
3	701-61172-00	Mount – Control .....	1
4	701-61170-00	Box – Junction .....	1
5	337-60346-00	Switch – Toggle (20 Amp, 1.5 Hp.).....	1
6	337-60360-01	Relay – Hybrid (With Surge Damper) .....	1
7	337-60317-01	Module – Relay .....	1
8	337-60409-01	Relay – Potential Start (Copeland) .....	1
9	510-10368-00	Clamp – Capacitor .....	1
10	337-60411-13	Capacitor – Start (Copeland) .....	1
11	336-60412-06	Capacitor – Run (Copeland) .....	1
12	510-10368-00	Clamp – Capacitor .....	1
13	701-61171-00	Mount Junction Box .....	1
	377-60038-00	Clip – Mounting (Not Shown).....	2
	333-60250-00	Harness (MIT II To Relay Module) (Not Shown) .....	1
	337-60070-00	Horn (Not Shown) .....	1

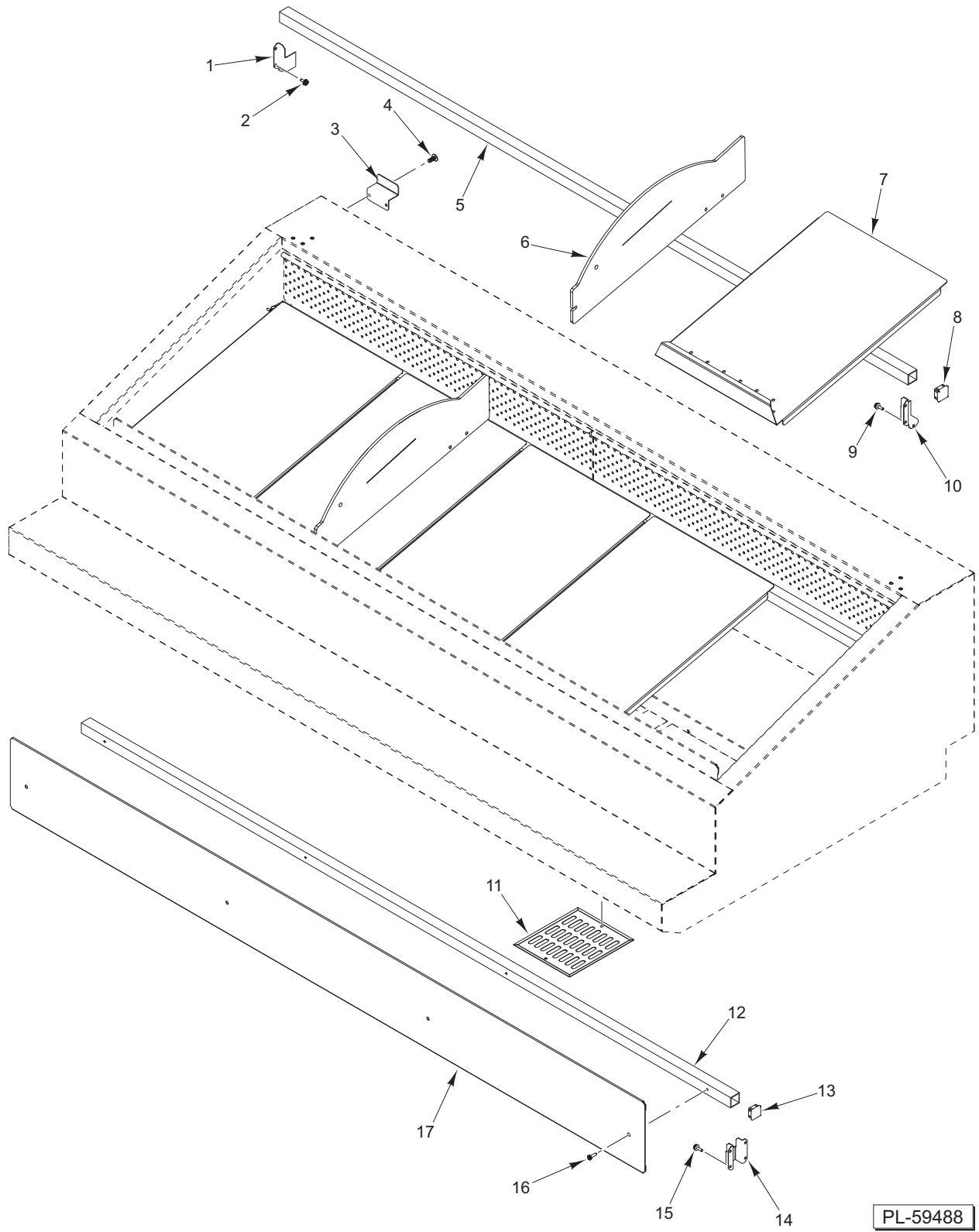

**WELL COMPONENTS**

**WELL COMPONENTS**

ILLUS.	PART NO.	NAME OF PART	AMT.
PL-59488			
1	510-10396-02	Bracket – Rear Bar Support (LH).....	1
2	351-60045-00	Mach. Screw 10-32 x 1/2 (With Sq. Cone Washer) (SST) .....	3
3	510-10427-00	Bracket – Product Bag.....	1
4	351-12798-06	Screw 10-32 x 1/2 Pan Hd. Truss.....	2
5	712-60238-00	Bar – Pan Support (Rear).....	1
6	377-60060-00	Divider – Pan .....	2
7	701-61366-00	Pan – Ice.....	5
8	353-60023-00	Cap – End (Sq. Plug).....	2
9	351-60045-00	Mach. Screw 10-32 x 1/2 (With Sq. Cone Washer) (SST) .....	3
10	510-10396-03	Bracket – Rear Bar Support (RH).....	1
11	601-61131-00	Cover – Motor Assy.....	2
12	712-60238-00	Bar – Pan Support (Front) .....	1
13	353-60023-00	Cap – End (Sq. Plug).....	2
14	510-10396-01	Bracket – Front Bar Support (LH/RH).....	2
15	351-60045-00	Mach. Screw 10-32 x 1/2 (With Sq. Cone Washer) (SST) .....	8
16	351-60003-01	Self-Tapping Screw 10 x 3/4 Phil. Hd. ....	4
17	701-61332-01	Baffle – Air (Front Display).....	1

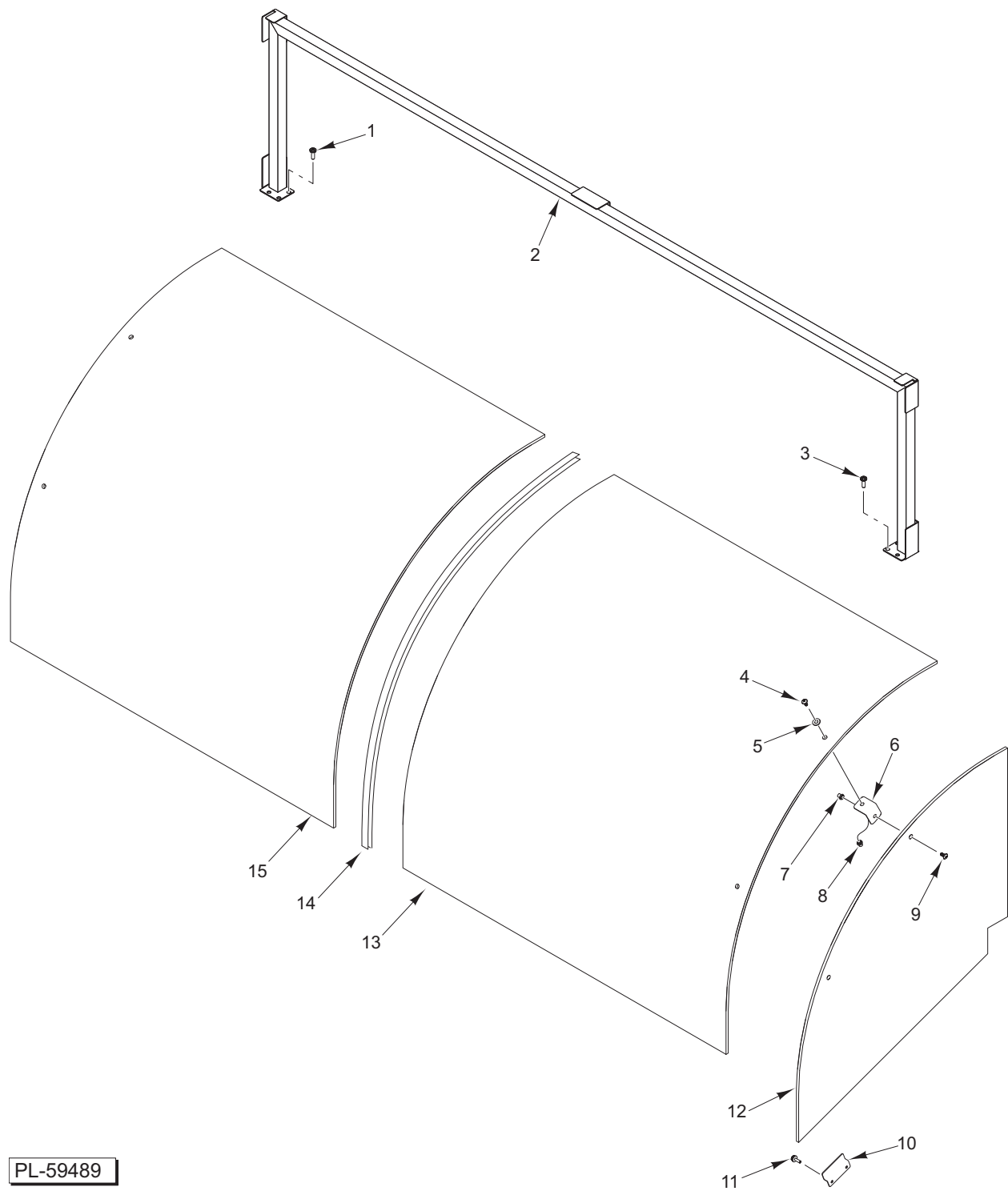

PL-59489

**FRONT AND SIDE PLEXIGLASS**



**FRONT AND SIDE PLEXIGLASS**

ILLUS.	PART NO.	NAME OF PART	AMT.
PL-59489			
1	351-60001-22	Mach. Screw 1/4-20 x 3/4 Phil. Pan Hd. ....	3
2	176-28033-00	Sneeze Shield Support Assy.....	1
3	351-60001-22	Mach. Screw 1/4-20 x 3/4 Phil. Pan Hd. ....	3
4	351-12798-06	Screw 10-32 x 1/2 Pan Hd. Truss.....	2
5	355-12937-00	Washer 1/4 Plain (SST).....	2
6	510-10443-00	Bracket – Side Canopy Support (Upper) .....	2
7	406-130-111-000	Rivet Nut 10-32 (SST) .....	2
8	406-130-111-000	Rivet Nut 10-32 (SST) .....	2
9	351-12798-06	Screw 10-32 x 1/2 Pan Hd. Truss.....	2
10	510-10451-00	Bracket – Side Canopy Support (Lower) .....	2
11	351-60045-00	Mach. Screw 10-32 x 1/2 (With Sq. Cone Washer) (SST) .....	4
12	377-60055-19	Plexiglass – Side Display.....	2
13	377-60055-20	Plexiglass – Front Display (RH).....	1
14	377-60062-00	Joiner – Plexiglass (H-Channel) (Clear Acrylic).....	1
15	377-60055-21	Plexiglass – Front Display (LH) .....	1
-	510-10441-00	Bracket - Water Level .....	1

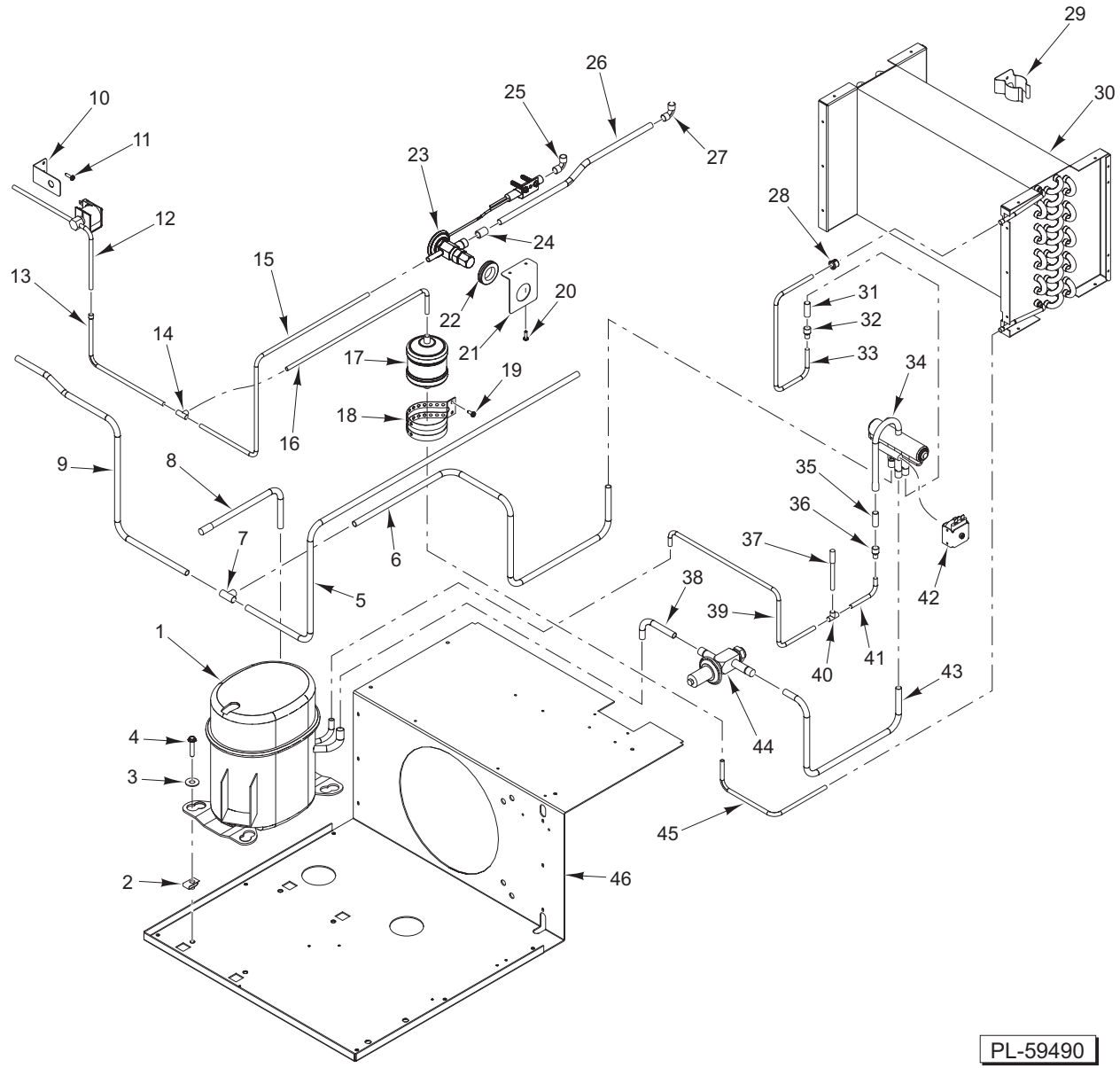

PL-59490

**CONDENSING UNIT**

**CONDENSING UNIT**

ILLUS. PL-59490	PART NO.	NAME OF PART	AMT.
1	321-60234-00	Compressor (RST64C1E-CFA-301) .....	1
2	356-60034-00	Speed Nut 1/4-20 (U Type).....	4
3	355-60019-00	Washer – Flat 5/8 x 7/8.....	4
4	SC-114-68	Mach. Screw 1/4-20 x 1 1/2 Hex Hd.....	4
5	326-60443-00	Tubing (Section Tee To Evaporator Out).....	1
6	326-60431-00	Tubing (Valve To Tee) .....	1
7	326-13087-01	Tee – Tubing .....	1
8	326-60437-00	Tubing – Process (3/8 In. x 10 In.) .....	1
9	326-60432-00	Tubing (Tee To Exchange Lever Evaporator Coil) .....	1
10	701-61273-00	Bracket – Mounting (Hot Gas/Liquid Flow) .....	1
11	351-60003-01	Self-Tapping Screw 10-16 x 3/4 Phil. Pan Hd.....	2
12	325-60108-00	Valve (Hot Gas/Liquid Flow) .....	1
13	326-60433-00	Tubing (Tee To Solenoid).....	1
14	326-13087-02	Tee – Tubing .....	1
15	326-60441-00	Tubing (Liquid Tee To TXV Inlet).....	1
16	326-60426-00	Tubing (Drier To Tee) .....	1
17	325-60162-00	Drier (Liquid Line Filter) .....	2
18	701-60796-00	Bracket – Drier.....	1
19	351-60003-02	Self-Tapping Screw 8-18 x 1/2 Phil. Pan Hd.....	2
20	351-60003-01	Self-Tapping Screw 10-16 x 3/4 Phil. Pan Hd.....	2
21	701-61285-00	Bracket (Valve Support).....	1
22	335-12377-00	Grommet.....	1
23	325-60080-35	Valve – TXV AA 1/8 SC (Emerson).....	1
24	326-60420-03	Coupling – Reducer 1/2 In. to 3/8 In. ....	1
25	326-13107-03	Elbow 90 Deg. I.D.....	1
26	326-60445-00	Tubing (TXV To Evaporator Inlet) .....	1
27	326-13107-03	Elbow 90 Deg. I.D.....	1
28	334-12213-04	Bushing 1/2 In. (Electric Snap) (SB-500-6) .....	1
29	353-60034-00	Clamp (For Drain Hose).....	1
30	322-60052-00	Condenser – Coil .....	1
31	326-60429-00	Tubing (3/8 In. O.D. x 1 In.) (Valve Adapter).....	1
32	326-60420-00	Coupling – Reducer, 3/8 In to 1/4 In.....	1
33	326-60425-00	Tubing (Inlet Valve To Condenser).....	1
34	325-60161-00	Valve – Reversing (4 Way) .....	1
35	326-60429-00	Tubing (3/8 In. O.D. x 1 In.) (Valve Adapter).....	1
36	326-60420-00	Coupling – Reducer, 3/8 In to 1/4 In.....	1
37	326-60436-00	Tubing – Process (1/4 In. x 3 In.) .....	1
38	326-60430-01	Tubing (CRO Valve To Compressor Suction).....	1
39	326-60428-00	Tubing (Valve to Tee, Compressor, & Condenser) (Incls. Item 41).....	1
40	326-13087-02	Tee – Tubing 1/4 In. CxCxC (W40306).....	1
41	326-60428-00	Tubing (Valve to Tee, Compressor, & Condenser) (Incls. Item 39).....	1
42	325-60163-00	Solenoid – Reversing Valve .....	1
43	326-60430-00	Tubing (TXV Valve To CRO Valve) .....	1
44	325-60173-00	Valve – CRO 3/8 In. Inlet/Outlet .....	1
45	326-60427-00	Tubing (Condenser To Drier) .....	1
46	701-61251-00	Base – Condenser Assy.....	1

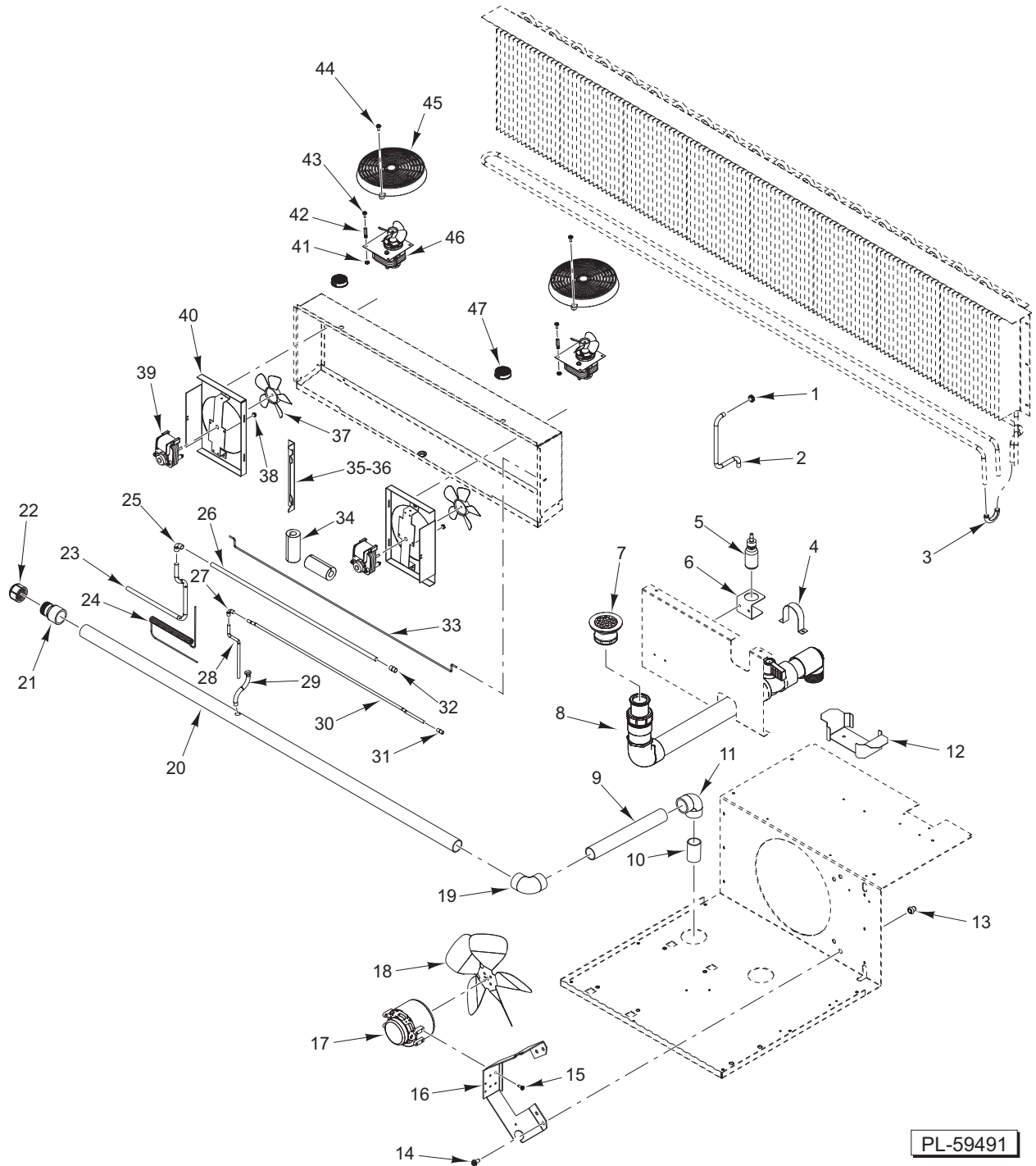

**HEAT EXCHANGE, FANS, AND TUBING**

HEAT EXCHANGE, FANS, AND TUBING

ILLUS.	PART NO.	NAME OF PART	AMT.
PL-59491			
1	335-12377-05	Grommet.....	1
2	326-60450-00	Tubing (Temperature Sensor Rail).....	1
3	326-60409-00	Tubing.....	1
4	701-61312-00	Bracket – Pipe Support.....	1
5	377-60061-01	Bottle – Fan Oil (10 Oz.).....	1
6	701-61330-00	Bracket – Holder (Plastic Oil Bottle).....	1
7	326-60536-00	Strainer – Sink Drain 2 <sup>7</sup> / <sub>8</sub> In. (SST).....	1
8	SER-60560-00	Drain Kit (With Valve).....	
9	326-60371-00	Tubing – PVC 1 In. Dia. (SCH 40) (Drain).....	1
10	326-60379-00	Tubing – PVC 1 In. Dia. 2 In. Lg. (SCH 40).....	1
11	326-60368-00	Elbow 90 Deg. ....	1
12	510-10452-00	Bracket – Cord.....	1
13	356-60024-00	Rivet Nut 1/4-20 (Open End).....	4
14	351-25542-03	Mach. Screw 1/4-20 x 1/2 Hex Washer Hd. ....	4
15	00-265181	Mach. Screw 8-36 x 3/8.....	4
16	510-10305-00	Bracket – Fan Mount.....	1
17	338-60050-00	Motor (16 W., 115 V.) (Incls. Speed Nut).....	1
18	325-60135-00	Blades – Fan 8 <sup>3</sup> / <sub>4</sub> In. Dia. 40 Deg. Pitch.....	1
19	326-60368-00	Elbow 90 Deg. ....	1
20	326-60367-04	Tubing – PVC 1 In. Dia. 51 <sup>1</sup> / <sub>2</sub> In. Lg. (SCH 40).....	1
21	326-60369-00	Reducer 1 In. PVC (SCH 40).....	1
22	326-60370-00	Cap – PVC 1 In. (SCH 40).....	1
23	326-60336-00	Tubing (Suction Line ES Evaporator Insert).....	1
24	326-60378-00	Tubing – Formed (Capillary).....	1
25	326-13107-03	Elbow 90 Deg. 3/8 O.D. (Solder).....	1
26	326-60380-14	Tubing (22.725 In.) (Suction Line).....	1
27	326-60351-00	Elbow 90 Deg. 1/4 In. O.D.....	1
28	326-60343-00	Tubing (Liquid Into Capillary).....	1
29	326-60451-00	Drain 3/8 In. Dia. (Copper).....	1
30	326-60381-00	Tubing – Liquid Line 11 <sup>1</sup> / <sub>4</sub> In. Lg. (Copper).....	1
31	326-13086-03	Coupling 1/4 In. O.D. (Solder).....	1
32	326-13086-02	Coupling 3/8 In. O.D. (Solder).....	1
33	701-61119-01	Rod – Spring 32 <sup>15</sup> / <sub>16</sub> In.....	1
34	327-60003-01	Tubing – Insulation 5/8 In. Dia.....	2
35	605-50058-00	Retainer – Coil & Fan.....	2
36	351-60090-00	Screw 10-16 x 3/8.....	4
37	00-433090	Blades – Fan.....	2
38	356-12942-00	Nut 8-32 Hex (SST).....	4
39	338-60054-00	Motor – Fan 120 V. (“C” Frame).....	2
40	325-60168-00	Bracket – Fan Mount (Incls. Items 39, 40, & 41).....	2
41	356-60017-02	Nut 8-32.....	8
42	351-60103-00	Extension – Threaded (Standoff).....	8
43	351-60095-00	Self-Sealing Screw 8-32 Pan Hd. ....	8
44	351-60045-00	Mach. Screw 10-32 x 1/2 (With Sq. Cone Washer) (SST).....	4
45	325-60102-00	Guard – Fan (Plastic).....	2
46	800-60075-00	Fan Assy. (Incls. Items 43 & 44).....	2
47	334-12213-04	Bushing – Snap (SB-500-6).....	2
	325-60144-00	Condenser Fan Assy. (Incls. Items 17 thru 20).....	1
	350-10001-04	Drain Pipe Assy. (Incls. Items 11, 12, 13, & 21 thru 24).....	1

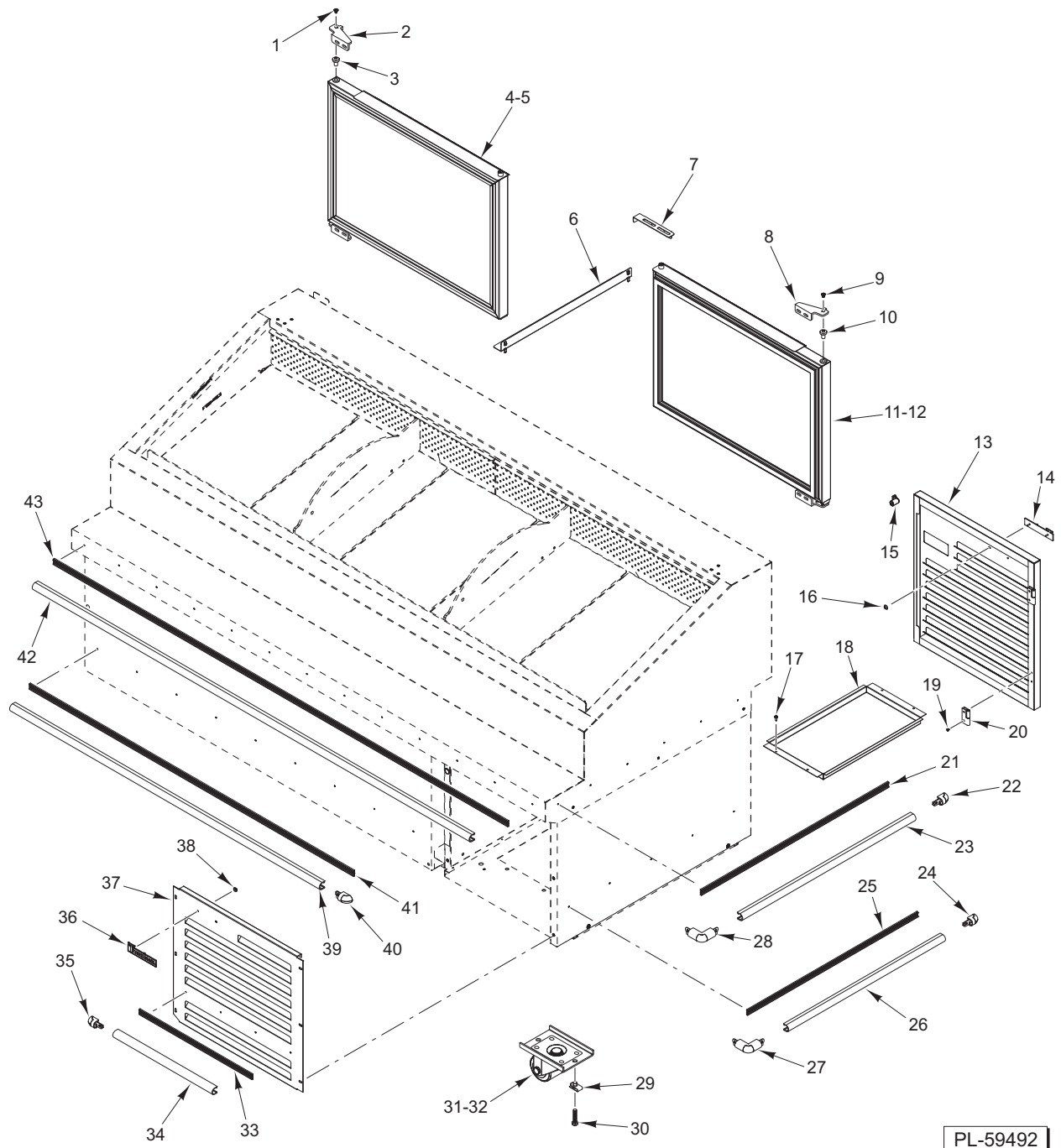

DISPLAY CASE BASE

DISPLAY CASE BASE

ILLUS. PL-59492	PART NO.	NAME OF PART	AMT.
1	358-10037-00	Pin – Upper Hinge (Pivot).....	1
2	282545	Bracket – Door (RH).....	1
3	SA-021-37	Mach. Screw 10-32 x 5/16 Phil. Rd. Hd. ....	1
4	200-60640-01	Door (RH) (Incls. Item 5).....	1
5	341-60199-00	Gasket .....	1
6	701-61323-00	Trayslide .....	AR
7	510-10445-00	Bracket – Door Latch.....	1
8	282544	Bracket – Door (LH).....	1
9	SA-021-37	Mach. Screw 10-32 x 5/16 Phil. Rd. Hd. ....	1
10	358-10037-00	Pin – Upper Hinge (Pivot).....	1
11	200-60640-00	Door (LH) (Incls. Item 12).....	1
12	341-60199-00	Gasket .....	1
13	500-60620-00	Louver Assy. (Front) (TD078).....	1
14	370-09735-00	Nameplate – Traulsen.....	1
15	344-60189-00	Magnet – Door Control .....	1
16	356-12950-01	Pal Nut 1/4 (Nonthreaded).....	1
17	351-60003-02	Self-Tapping Screw 8-18 x 1/2 Phil. Pan Hd.....	1
18	701-61173-00	Pan – Condensate .....	1
19	358-10000-00	Pop Rivet 1/8.....	1
20	344-60165-00	Hinge –Liftoff 2 In. (SST).....	1
21	345-60071-01	Base – Upper Bumper (Side).....	2
22	345-60073-00	Cap – Bumper.....	2
23	345-60072-01	Bumper – Upper (Side).....	2
24	345-60073-00	Corner – Bumper .....	2
25	345-60071-05	Mount – Lower Bumper (Side).....	2
26	345-60072-05	Bumper – Lower (Side).....	2
27	345-60074-00	Elbow – Bumper .....	2
28	345-60074-00	Elbow – Bumper .....	2
29	356-60034-00	Speed Nut 1/4-20 .....	12
30	351-12960-17	Cap Screw 1/4-20 x 11/4 .....	12
31	348-10013-01	Caster 3 1/8 In. (With Brake).....	2
32	348-10013-00	Caster 3 1/8 In. (Without Brake).....	4
33	345-60071-06	Mount – Lower Bumper (Panel).....	1
34	345-60072-06	Bumper – Lower (Panel).....	1
35	345-60073-00	Corner – Bumper .....	1
36	370-09735-00	Nameplate – Traulsen.....	1
37	514-50059-01	Louver Panel (Customer Side) .....	1
38	356-12950-00	Pal Nut 1/4 (Nonthreaded).....	1
39	345-60072-03	Bumper – Lower (Front).....	1
40	345-60073-00	Corner – Bumper .....	1
41	345-60071-03	Base – Lower Bumper (Front) .....	1
42	345-60072-02	Bumper – Upper (Front).....	1
43	345-60071-02	Base – Upper Bumper (Front) .....	1
	342-60090-00	Pilaster – Trayslide Side .....	4
	342-60089-00	Pilaster – Trayslide Center.....	4

