



cial
tor
nual

Mega Top Prep Table

Model: MST-28-12

MST-48-18

MST-60-24

MST-72-30

TAI

1. |

2. |

2-1. MST-48-12 / MST-50-18

2-2. MST-60-24 / MST-72-30

3. MAIN COMPONENTS

4. TEMPERATURE CONTROL INSTRUCTION

5. PARTS LIST

6. REPLACEMENT OF MAIN COMPONENTS

6-1. REPLACING DOOR

6-2. REFRIGERATION COMPARTMENT PARTS

6-3. COMPRESSOR COMPARTMENT PARTS

6-4. REPLACING THE EVAPORATOR & EVAPORATOR FAN MOTOR

1. E
1-1.

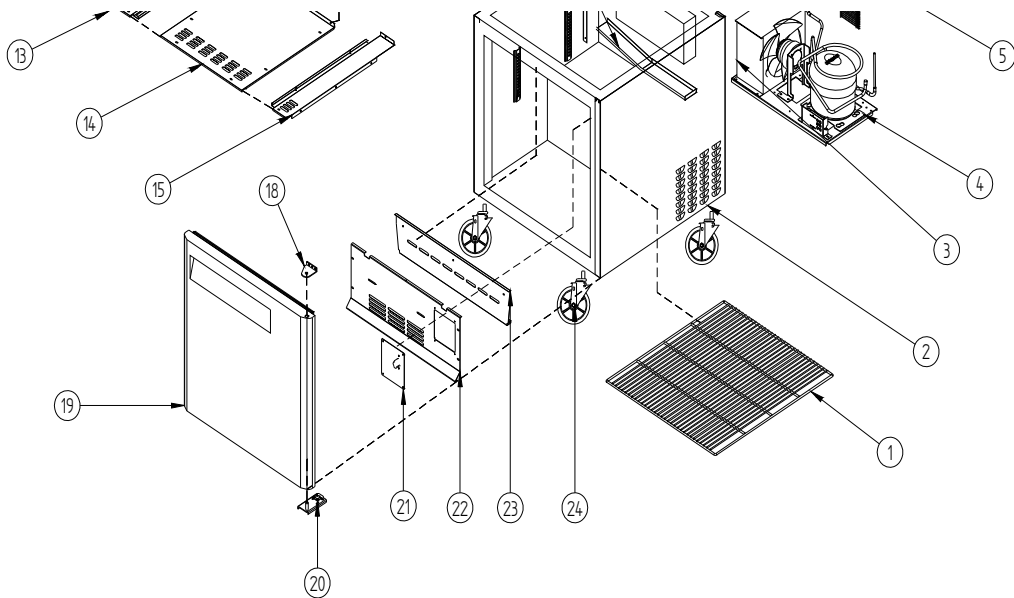

© Part Name

1	SHELF	11	EVAPORATOR FAN DUCT	21	TAMPERATURE CONTROL COVER
2	CABINET ASSEMBLY	12	LOUVE	22	EVAPORATOR DUCT
3	CONDENSER ASSEMBLY	13	PAN DUCT SIDE(LF)	23	PAN DUCT FRONT
4	COMPRESSOR	14	PAN DUCT MID	24	CASTER
5	MECH COVER	15	PAN DUCT SIDE(RH)		
6	HOOD	16	EVAPORATOR ASSEMBLY		
7	HOOD LID	17	EVAPORATOR DRAIN GUI		
8	COUNTER TOP	18	TOP HINGE		
9	BRACKET BOARD KITCHEN	19	DOOR ASSEMBLY		
10	BOARD KITCHEN	20	BOTTOM HINGE		

1-2.

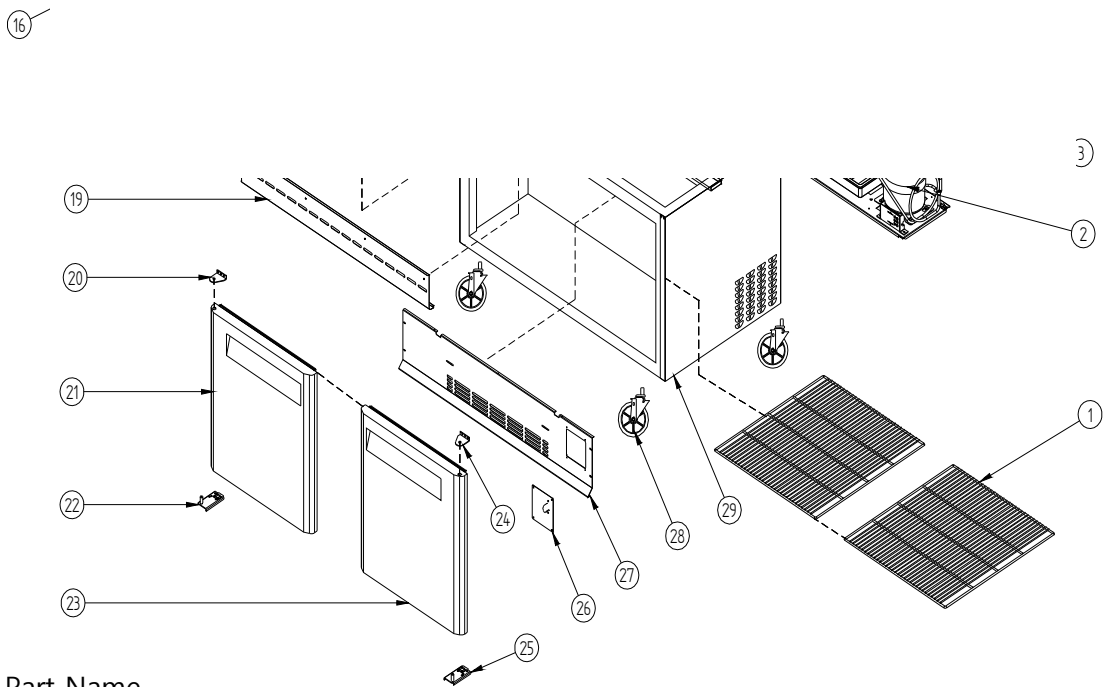
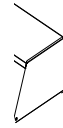

© Part Name

1	SHELF	13	LOUVER	25	BOTTOM HINGE(RH)
2	COMPRESSOR	14	EVAPORATOR	26	TAMPERATURE CONTROL COVER
3	CONDENSER ASSEMBLY	15	EVAP DRAIN GUIDE	27	EVAPORATOR DUCT
4	MECH COVER(RH)	16	PAN DUCT SIDE(LF)	28	CASTER
5	UNIT COVER	17	PAN DUCT MID	29	CABINET ASSEMBLY
6	MECH COVER(LF)	18	PAN DUCT SIDE(RH)		
7	HOOD	19	PAN DUCT FRONT		
8	HOOD LID	20	TOP HINGE(LF)		
9	COUNTER TOP ASSEMBLY	21	DOOR ASSEMBLY(LF)		
10	BRACKET BOARD KITCHEN	22	BOTTOM HINGE(LF)		
11	BOARD KITCHEN	23	DOOR ASSEMBLY(RH)		
12	EVAPORATOR FAN DUCT	24	TOP HINGE(RH)		

1-3.

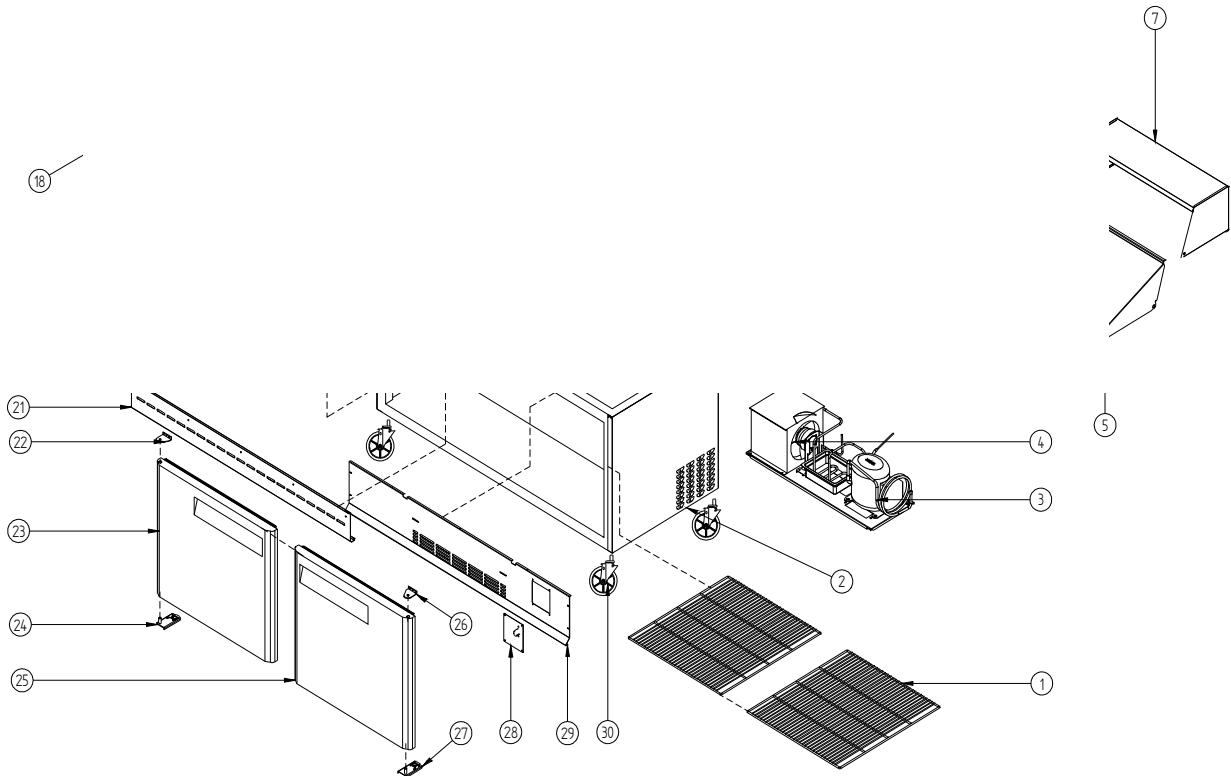

◎ Part Name

1	SHELF	14	EVAPORATOR	27	BOTTOM HINGE(RH)
2	CABINET ASSEMBLY	15	EVAP DRAIN GUIDE	28	TAMPERATURE CONTROL COVER
3	COMPRESSOR	16	EVAP FAN DUCT	29	EVAPORATOR DUCT
4	CONDENSER ASSEMBLY	17	LOUVER	30	CASTER
5	HOOD LID	18	PAN DUCT SIDE(LF)		
6	BRACKET BOARD KITCHEN	19	PAN DUCT MID		
7	HOOD	20	PAN DUCT SIDE(RH)		
8	COUNTER TOP ASSEMBLY	21	PAN DUCT FRONT		
9	HOOD	22	TOP HINGE(LF)		
10	BOARD KITCHEN	23	DOOR ASSEMBLY(LF)		
11	MECH COVER(RH)	24	BOTTOM HINGE(LF)		
12	UNIT COVER	25	DOOR ASSEMBLY(RH)		
13	MECH COVER(LF)	26	TOP HINGE(RH)		

1-4.N

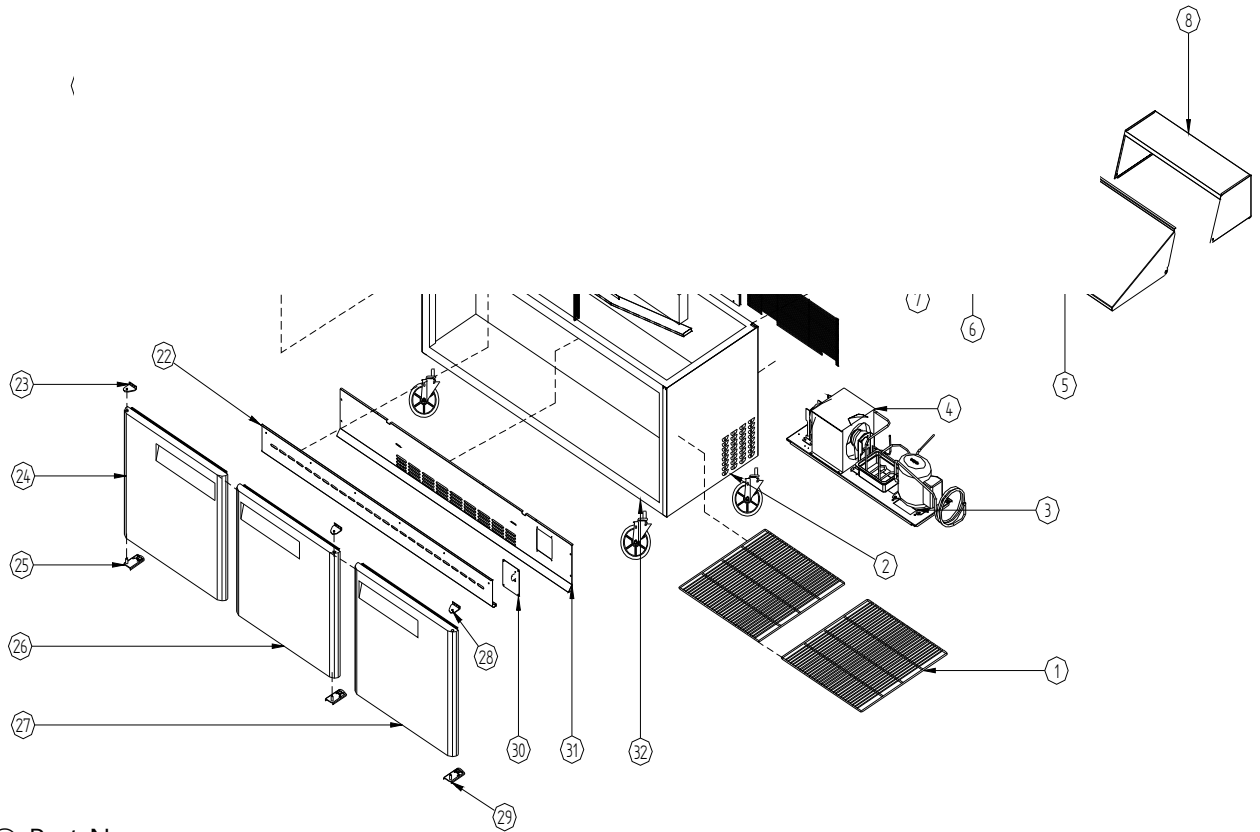

© Part Name

1	SHELF	14	EVAP DRIAN GUIDE	27	DOOR ASSEMBLY(RH)
2	CABINET ASSEMBLY	15	EVAPORATOR	28	TOP HINGE(RH)
3	COMPRESSOR	16	MECH COVER(LF)	29	BOTTOM HINGE(RH)
4	CONDENSER ASSEMBLY	17	UNIT COVER	30	TAMPERATURE CONTROL COVER
5	HOOD LID(RH)	18	MECH COVER(RH)	31	EVAPORATOR DUCT
6	BRACKET BOARD KITCHEN	19	PAN DUCT SIDE(LF)	32	CASTER
7	BRACKET BOARD	20	PAN DUCT MID		
8	HOOD(RH)	21	PAN DUCT SIDE(RH)		
9	COUNTER TOP ASSEMBLY	22	PAN DUCT FRONT		
10	HOOD(LF)	23	TOP HINGE(LF)		
11	HOOD LID(LF)	24	DOOR ASSEMBLY(LF)		
12	EVAPORATOR FAN DUCT	25	BOTTOM HINGE(LF)		
13	LOUVER	26	DOOR ASSEMBLY(MID)		

2. W

2-1. 1

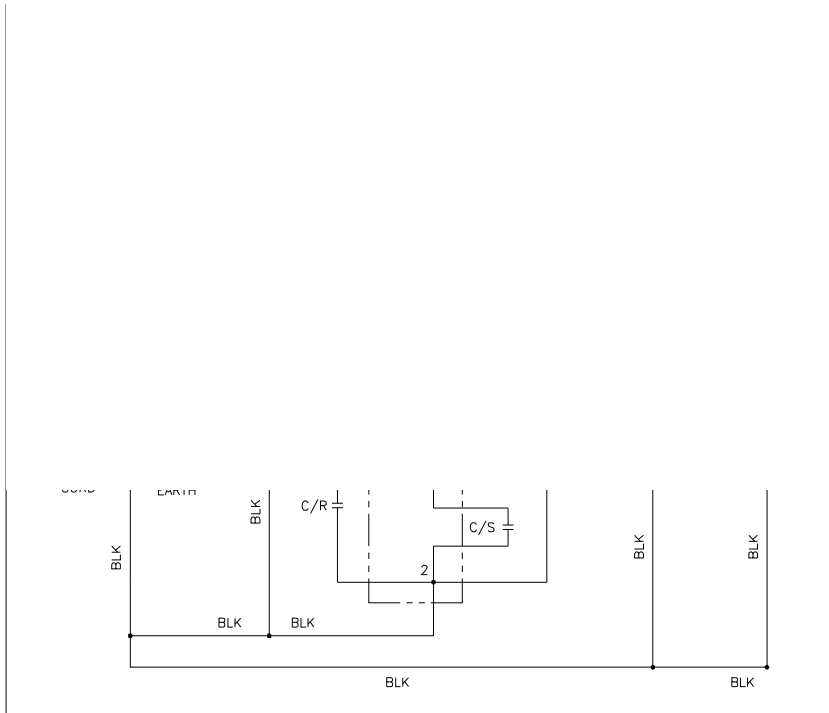

2-2. MST-60-24 / MST-72-30

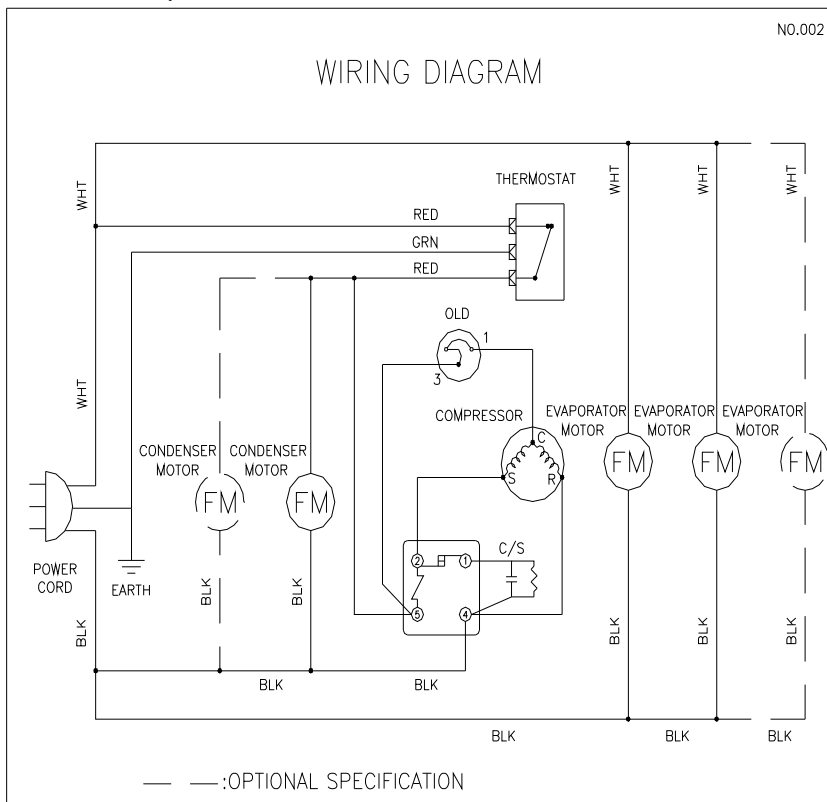

3.M.

1.COM

MOD
MST-2
MST-4
MST-6
MST-7

MAKER
DAEWOO
SAMSUNG
ECUMSHE
ECUMSHE

2.COI

MOD
MST-2
MST-4
MST-6
MST-7

OTE
~
~
~
~

3.COMPRESSOR CAPACITOR

MODEL	STARTING	PART NO.	RUNNING	PART NO.	MAKER	NOTE
MST-28-12	200V/100uF	~	230V/10uF	~	~	~
MST-48-18	125V/125uF	~	250V/12uF	~	~	~
MST-60-24	160V/315uF	~	~	~	~	~
MST-72-30	160V/315uF	~	~	~	~	~

4.CONDENSER FAN MOTOR

MODEL	PART NAME	PART NO.	INPUT	TYPE	BLADE	MAKER
MST-28-12	IS-4420DWSN-2A	3963328120	115V 60Hz	SHADED POLE INDUCTION	AL 5	SUNGSHIN
MST-48-18	IS-4420DWSN-2A	3963328120				
MST-60-24	IS-4420DWSN-2A	3963328120				
MST-72-30	IS-4420DWSN-2A	3963328120				

5.EVAPORATOR FAN MOTOR

MODEL	PART NAME	PART NO.	POLE	INPUT	TYPE	BLADE (NUMBER)	NO
MST-28-12	DAI-6202DEUA	M729900200	2P	115v60Hz	SHADED POLE INDUCTION	ZYTEL 4	SUNGSHIN
MST-48-18	DAI-6202DEUA		2P	115v60Hz			
MST-60-24	DAI-6202DEUA		2P	115v60Hz			
MST-72-30	DAI-6202DEUA		2P	115v60Hz			

6.THERMOSTAT

PART NAME	PART NO.	RATING	MAKER
THERMOSTAT	30283L0100	K55Q-5607,16A	RANCO
		MST-28-12	
		MST-48-18,MST-60-24,MST-72-30	

4.T

-

-

©

S

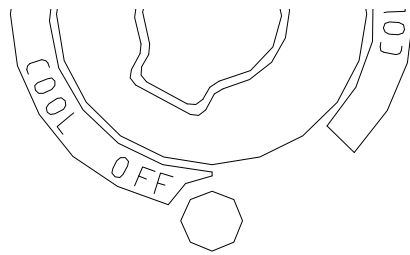

TEMPERATURE
CONTROLLER

- If thermostat knob is pointing at OFF, compressor and condenser fan motor would not run.
- Keep unit unplugged, if not in use for a long period of time.

5. F

							Remark
1. DOC							
DOOR A							
DOOR A							
DOOR A							
DOOR A							
DOOR A							
DOOR A							
DOOR B							
DOOR C							
DOOR C							
DOOR C							
TOP HINGE (L)							
	M722900200			1	1	1	
TOP HINGE SPACER	M725000100		1	2	2	3	
BOTTOM HINGE (U)(R)	30229M0400	SUS304,SM45C	1	1	1	2	
BOTTOM HINGE (U)(L)	30229M0300	SUS304,SM45C		1	1	1	
SPRING BAR			1	2	2	3	
2. COUNTER TOP							
COUNTER TOP ASSEMBLY	M275700200		1				
COUNTER TOP ASSEMBLY	M485700200			1			
COUNTER TOP ASSEMBLY	D605700200				1		
COUNTER TOP ASSEMBLY	D725700200					1	
CASTER	M726500100		2	2	2	2	
CASTER	M726500200		2	2	2	2	
3. COMPRESSOR COMPAR							
COMPRESSOR	M369700100		1				
COMPRESSOR	M609700100			1			
COMPRESSOR	M729700100				1	1	
SUCTION PIPE(B)	M364400200		1				
SUCTION PIPE(B)	M604400200	CU		1			
SUCTION PIPE(B)	M604400800	CU			1		
SUCTION PIPE(B)	M724400200	CU				1	
SUCTION PIPE(A)	M274400100	CU	1				
SUCTION PIPE(A)	M604400900	CU			1		
SUCTION PIPE(A)	M604400400	CU		1			
SUCTION PIPE(A)	M724400100	CU				1	
COMP BASE	M270300100	GI	1				
BRACKET MOTOR	30220T0300	SUS304	2	2	2	3	
FAN COOLING BLADE	3011802210	ZYTEL	1	1	1	1	
PAN	30211M0100	PC	12	18	24	30	

	Remark
COMP E	
COMP E	
COMP E	
CONDEI	
POWER	
CONDEI	
DRAIN F	
DRAIN F	
DRAIN F	
DRAIN F	
CONDEI	
CONDEI	

Part Name	Part Code	Description	Model				Remark
			28	48	60	72	
4. REFRIGERATION COMPARTMENT							
PAN SUPPORT ASS'Y	M270001200	SUS304-2B	1				
PAN SUPPORT ASS'Y	M480001100			1			
PAN SUPPORT ASS'Y	M600001300				1		
PAN SUPPORT ASS'Y	M720002500					1	
EVAP FAN MOTOR	M729900200		2	2	2	3	
KITCHEN BOARD	M279400100	MIPS	1				
KITCHEN BOARD	M489400100			1			
KITCHEN BOARD	M609400100				1		
KITCHEN BOARD	M729400100					1	
PAN DUCT MID	M276900500		1				
PAN DUCT MID	M606900500			1	1		
PAN DUCT MID	M726900500	SUS304-2B				1	
PAN DUCT SIDE(L)	M276900100	SUS304-2B	1				
PAN DUCT SIDE(L)	M486900100	SUS304-2B		1			
PAN DUCT SIDE(L)	M726900100	SUS304-2B			1	1	
PAN DUCT SIDE(R)	M276900400	SUS304-2B	1				
PAN DUCT SIDE(R)	M486900400	SUS304-2B		1			
PAN DUCT SIDE(R)	M726900400	SUS304-2B			1	1	
PAN DUCT FRONT	M276900600	SUS304-2B	1				
PAN DUCT FRONT	M486900600	SUS304-2B		1			
PAN DUCT FRONT	M606900600	SUS304-2B			1		

							Remark
PAN DUCT							
LOUVER							
LOUVER							
LOUVER							
LOUVER							
SHELF							
SHELF							
SHELF							
SHELF MII							
FIXTURE :							
SHELF MII							
SHELF ST,							
DRAIN PAI							
DRAIN PAI							
EVAPORATOR AS	M367000100	CU,SPG,AL	1				
EVAPORATOR AS	M487000200	CU,SPG,AL		1			
EVAPORATOR AS	M607000100	CU,SPG,AL			1		
EVAPORATOR AS	M727000100	CU,SPG,AL				1	
THERMOSTAT	30283L0100	250V,16A K55Q -5607	1	1	1	1	
EVAPOVATOR FAN DUCT	M276900200	SUS439-2B	1				
EVAPOVATOR FAN DUCT	M486900200	SUS439-2B		1			
EVAPOVATOR FAN DUCT	M606900200	SUS439-2B			1		
EVAPOVATOR FAN DUCT	M726900200	SUS439-2B				1	
EVAPOVATOR DUCT	M276900300	SUS439-2B	1				
EVAPOVATOR DUCT	M486900300			1			
EVAPOVATOR DUCT	M606900300				1		
EVAPOVATOR DUCT	M726900300					1	
FIXTURE EVAP DUCT BRACKET	M720601000		2	2	2	2	
HOOD LID	WM28900100	SUS439-#4	1				
HOOD LID	WM48900300			1			
HOOD LID	WD68900300				2	1	
HOOD LID	WD78900300					1	
MULLION FRAME	M722200400			1	1	2	
MULLION BACK FRAME	M722200200			1	1	2	
MULLION FRAME INSULATION	M723300100			1	1	2	
CONDENSER AS	M365900100		1				
CONDENSER AS	M605900100			1			
CONDENSER AS	M725900100				1	1	
HOOD SHAFT SPACER	M725000400		2	2	4	4	
HOOD HINGE	M724900100		2	2	4	4	
BRACKET BOARD KITCHEN(L)	M720601301		1	1	1	1	
BRACKET BOARD KITCHEN(R)	30206P1902	SUS304	1	1	1	1	
PAN GUIDE	M722500100	SUS304	3	5	7	9	

6. R

6-1.

A. Ur

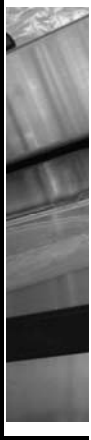

6-2. REFRIGERATION COMPARTMENT PARTS

A. Disassemble the evaporator fan duct assembly

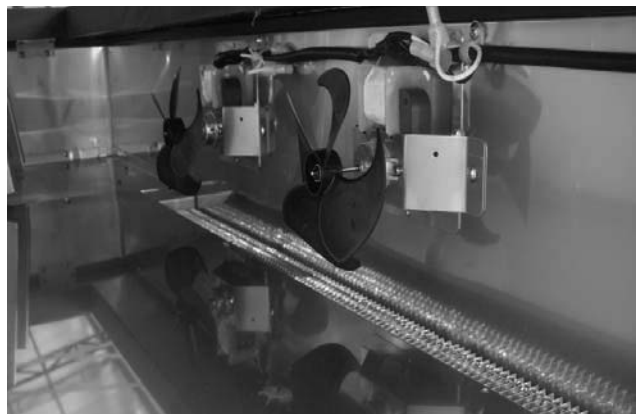

B. Disassemble the evaporator duct



C.Rer



6-3.

A.Dis

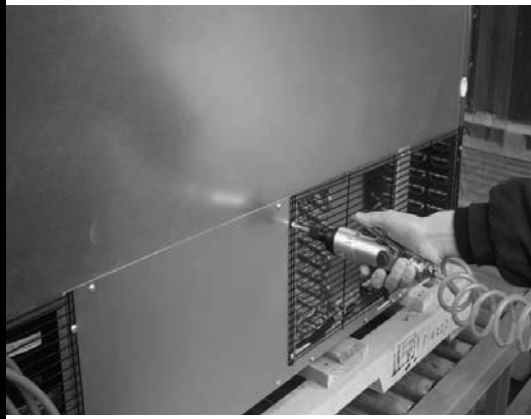

B.Disassembly the condensing unit

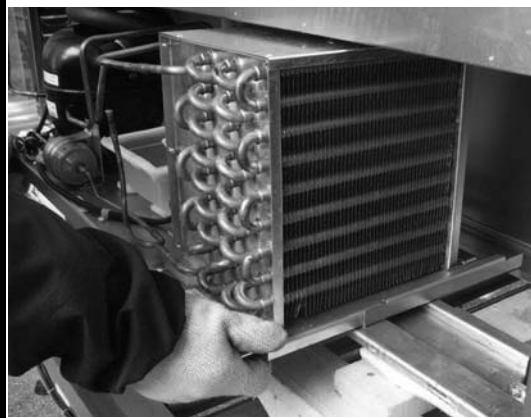

6-4.

