

REFRIGERATOR MANUFACTURER
Turbo air

Turbo Air Speed up the Pace of Innovation

CAUTION!
PLEASE KEEP POWER
SWITCH ON BEFORE
OPERATING THIS EQUIPMENT

Glass Door Ice Merchandisers Service Manual

Please read this manual completely before attempting to install or operate this equipment!

TGIM-23
TGIM-49

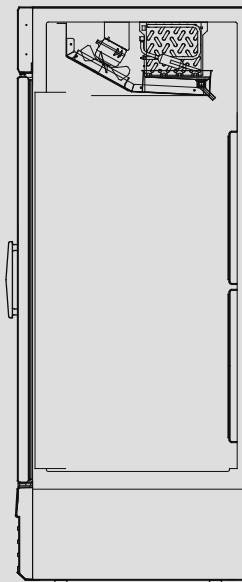
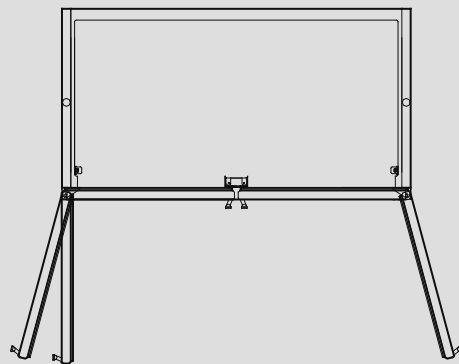

TABLE OF CONTENTS

<ICE MERCHANDISER>

- 1. FEATURE CHART**
- 2. PART DETAILS**
- 3. WIRING DIAGRAM**
- 4. SPECIFICATION OF MAIN COMPONENTS**
- 5. MAIN PCB PROGRAMING**
- 6. PARTS LIST**
- 7. REPLACEMENT OF MAIN COMPONENTS**
 - 1. TGIM-23***
 - 2. TGIM-49***

1. FEATURE CHART

• Model : TGIM-23*

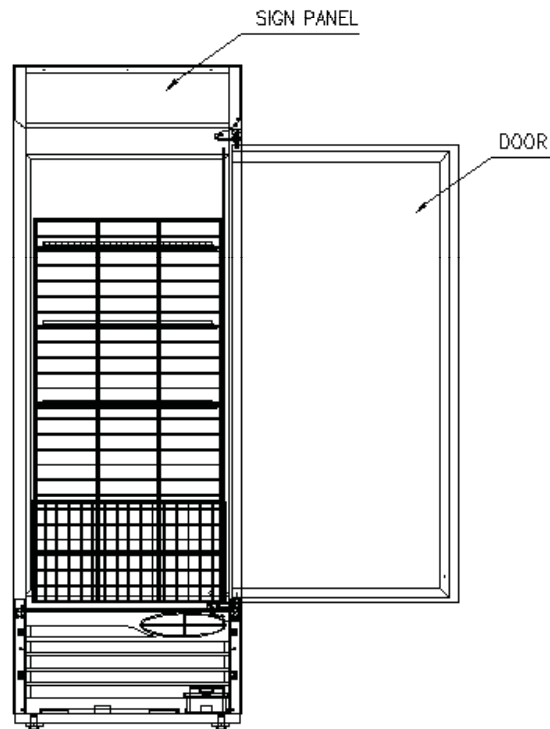

<FRONT>

• Model : TGIM-23*

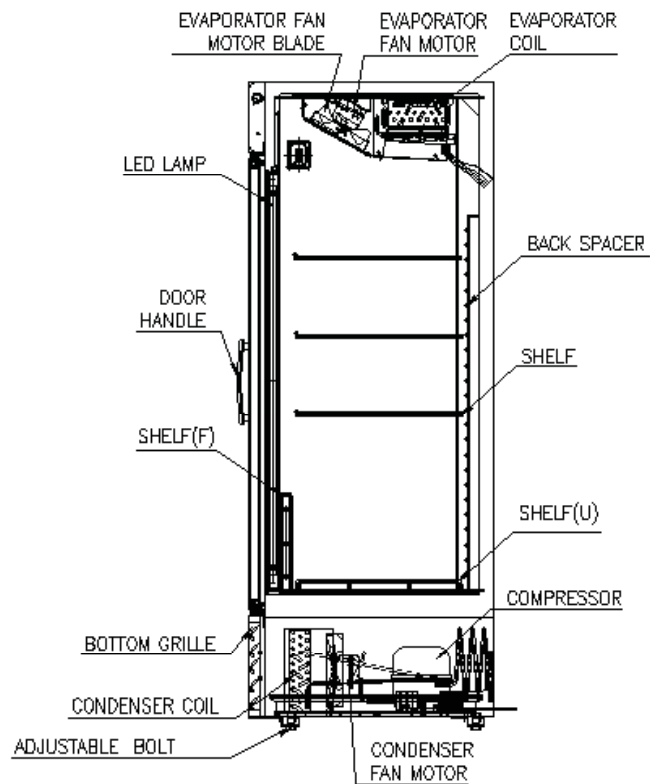

<SIDE>

FEATURE CHART

• Model : TGIM-49*

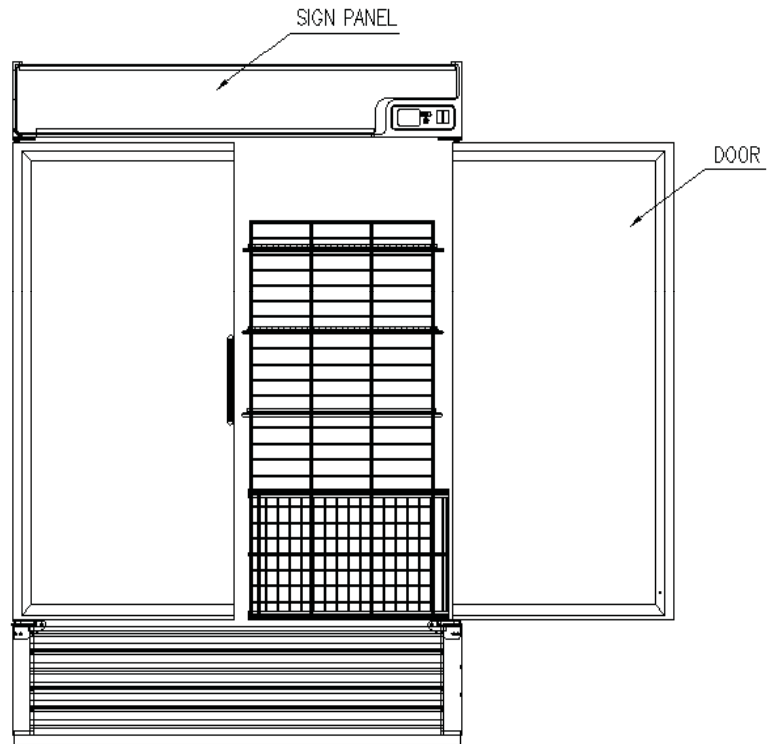

<FRONT>

• Model : TGIM-49*

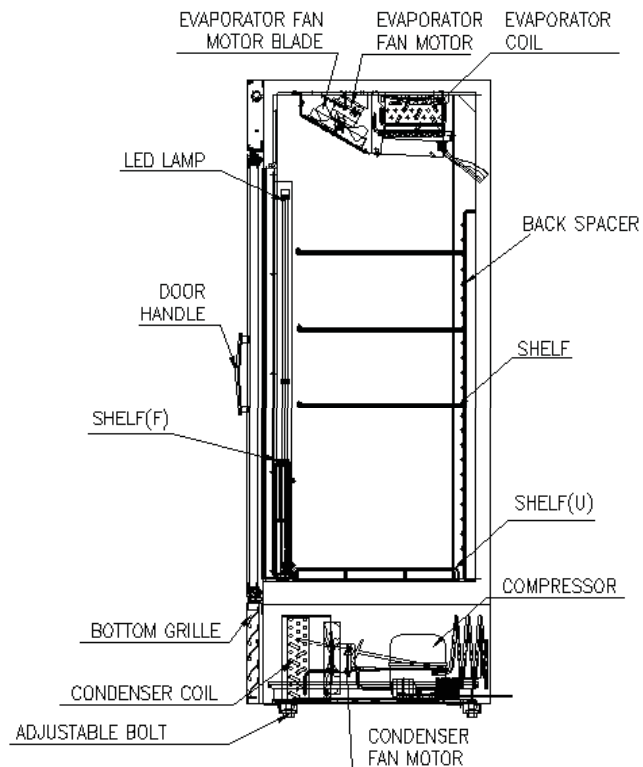

<SIDE>

2. PART DETAILS

DOOR PARTS : TGIM-23*, TGIM-49*

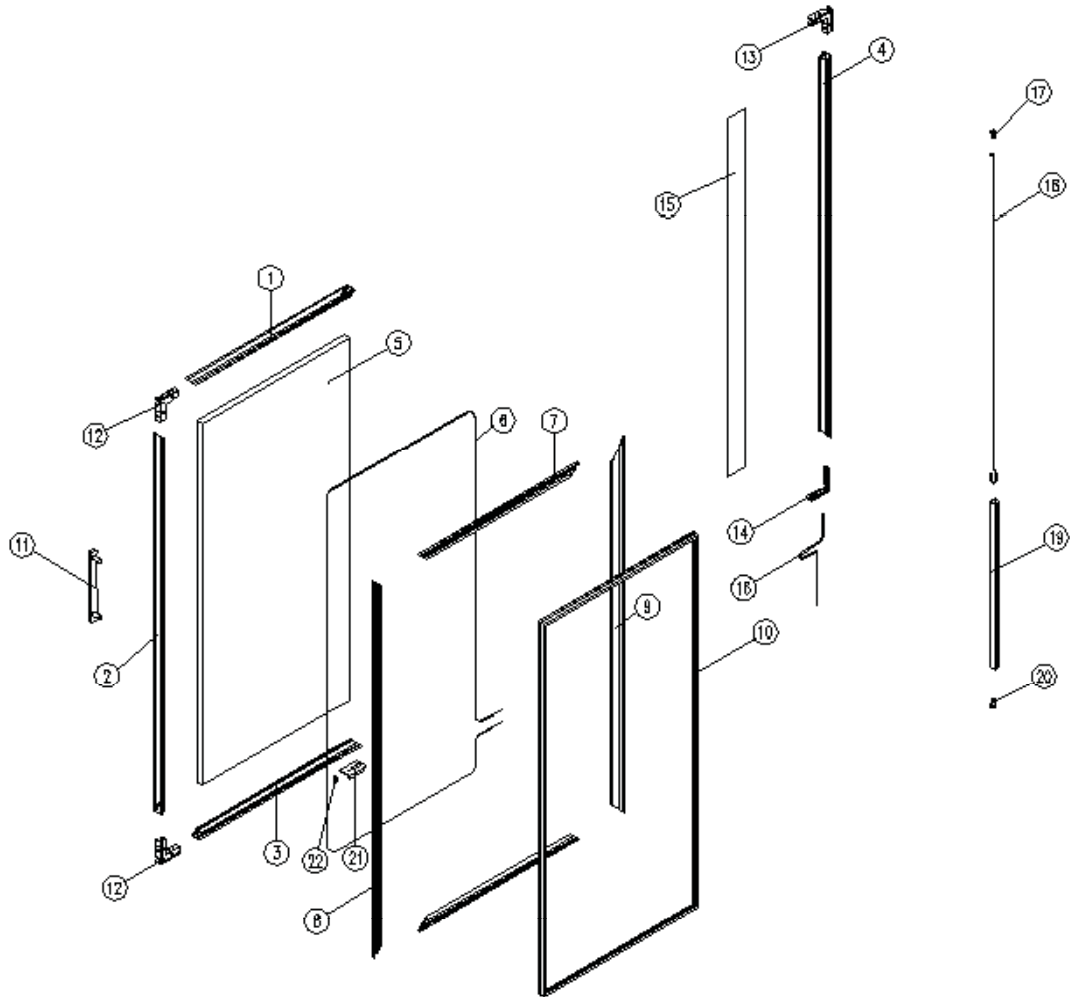

01 DOOR FRAME *TOP	09 AUXILIARY DOOR FRAME *A	17 DOOR BUSHING *TOP
02 DOOR FRAME *LEFT	10 DOOR GASKET	18 BAR SPRING
03 DOOR FRAME *BOTTOM	11 DOOR HANDLE	19 BAR SPRING FIXTURE
04 DOOR FRAME *RIGHT	12 DOOR FRAME FIXTURE- A	20 DOOR BUSHING *BOTTOM
05 DOOR GLASS	13 DOOR FRAME FIXTURE- B	21 DOOR STOPPER-A
06 DOOR FRAME HEATER	14 DOOR FRAME FIXTURE- D	22 CORD BUSHING
07 AUXILIARY DOOR FRAME *TOP *BOTTOM	15 DOOR SIGN PANEL	
08 AUXILIARY DOOR FRAME *LEFT *RIGHT	16 DOOR HEATER HARNESS	

PART DETAILS

▶ DUCT(TGIM-23*)

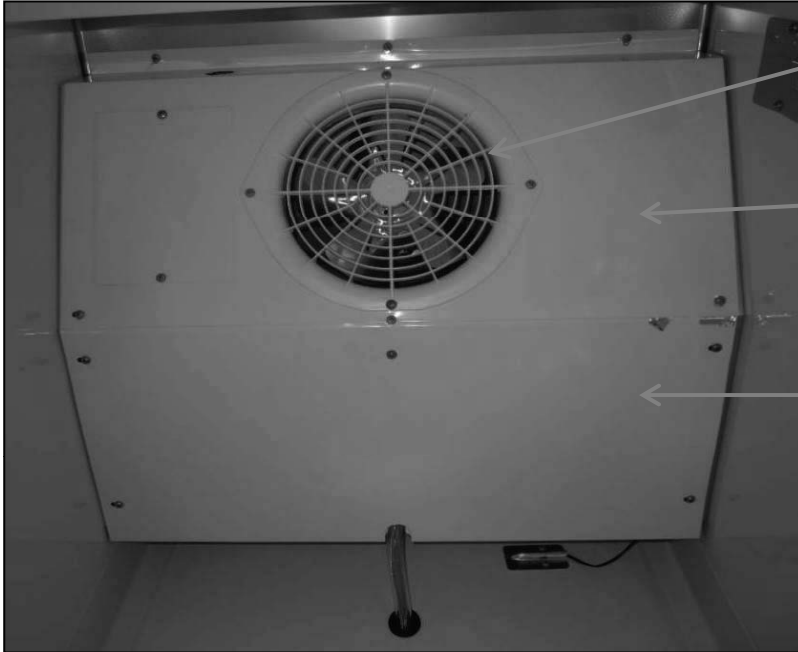

EVAPORATOR
FAN GRILLE GUARD

EVAPORATOR
FRONT COVER

EVAPORATOR
BOTTOM COVER

▶ EVAPORATOR, FAN MOTOR, DEFROST HEATER, SENSORS(TGIM-23*)



EVAPORATOR
FAN MOTOR & BLADE

EVAPORATOR COIL

THERMAL
PROTECTOR

DEFROST HEATER

DEFROST SENSOR

F-SENSOR
(TEMPERATURE CONTROL)

PART DETAILS

▶ DUCT(TGIM-49*)

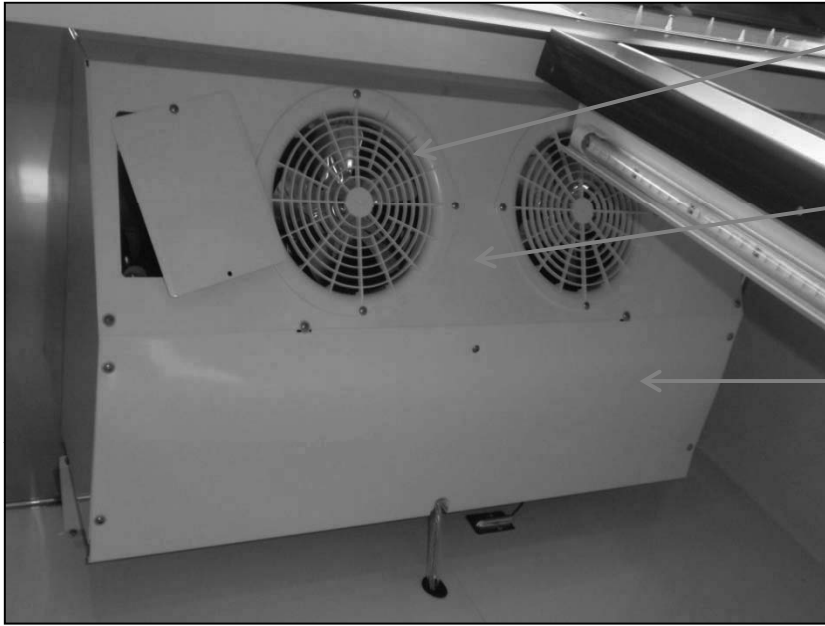

EVAPORATOR
FAN GRILLE GUARD

EVAPORATOR
FRONT COVER

EVAPORATOR
BOTTOM COVER

▶ EVAPORATOR, FAN MOTOR, DEFROST HEATER, SENSORS(TGIM-49*)



EVAPORATOR
FAN MOTOR & BLADE

THERMAL
PROTECTOR

EVAPORATOR COIL

DEFROST HEATER

DEFROST SENSOR

F-SENSOR
(TEMPERATURE CONTROL)

PART DETAILS

▶ COMPRESSOR & FAN MOTOR(TGIM-23*)

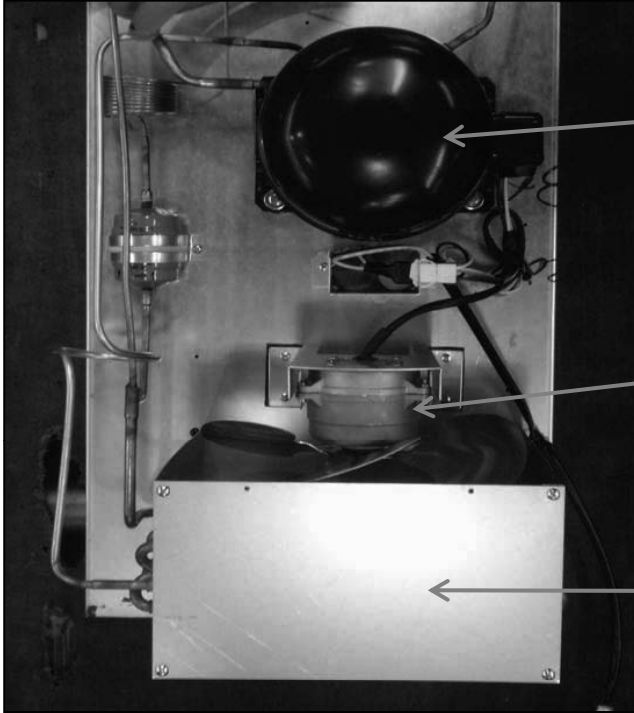

COMPRESSOR

CONDENSER
FAN MOTOR

CONDENSER

▶ COMPRESSOR & FAN MOTOR(TGIM-49*)

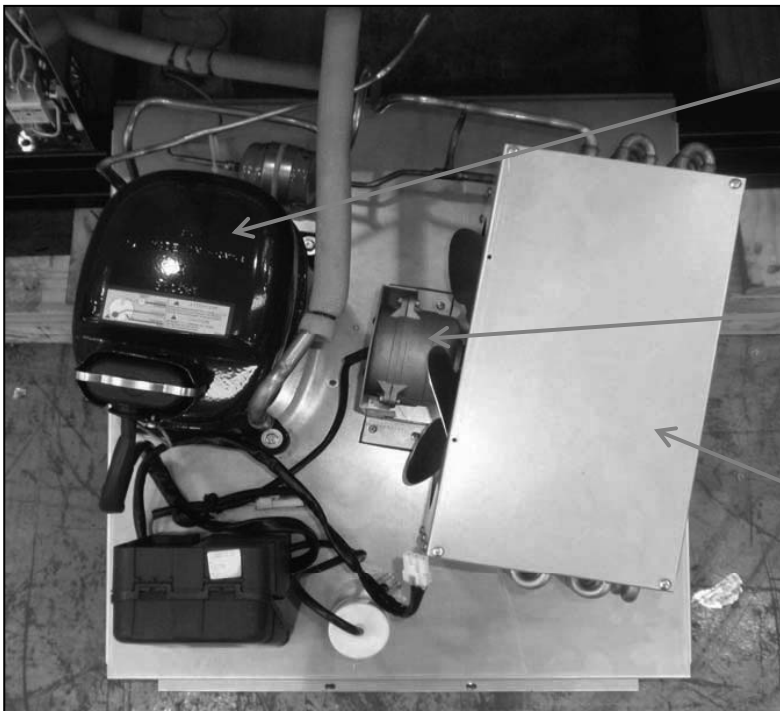

COMPRESSOR

CONDENSER
FAN MOTOR

CONDENSER

3. WIRING DIAGRAM

• Model : TGIM-23*

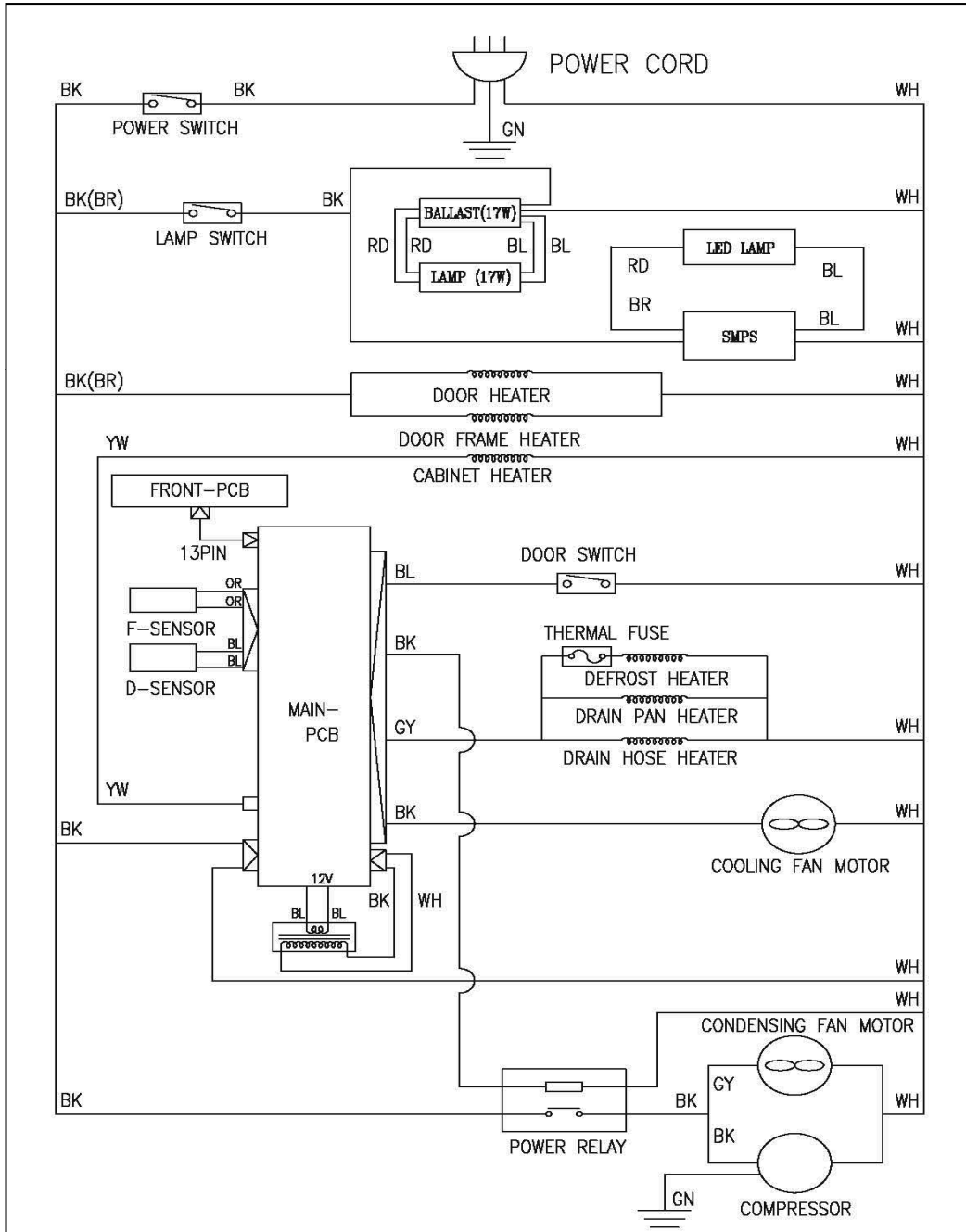

WIRING DIAGRAM

• Model : TGIM-49*

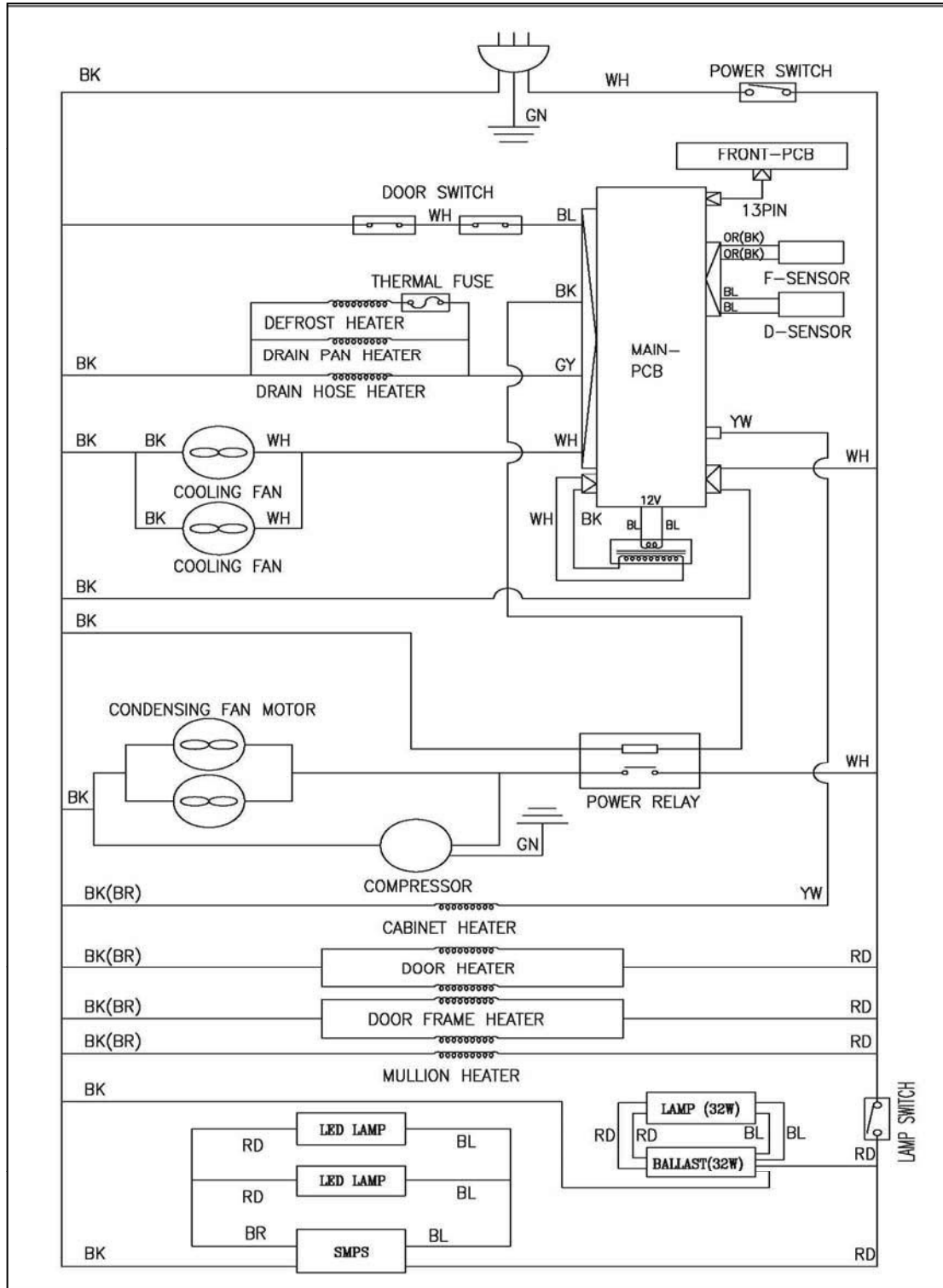

4. SPECIFICATION OF MAIN COMPONENTS

1. COMPRESSOR

MODEL	PART NAME	PART NO.	HORSE POWER	CAPACITY	TYPE OF MOTOR	Current (RLA)	MAKER
TGIM-23*	SK1A1C-L2W	30200Q1200	1/3 HP	1,203 BTU/h (303 Kcal/h)	LBP CSR	3.85A	SAMSUNG
TGIM-49*	CAJ2432Z	30200R1000	2/3 HP	3,200 BTU/h (807 Kcal/h)	LBP CSR	7.0A	TECUMSEH

MODEL	BASIC COMPRESSOR			EXCHANGEABLE COMPRESSOR		
	PART NAME	MOTOR TYPE	MAKER	PART NAME	MOTOR TYPE	MAKER
TGIM-23*	SK1A1C-L2W	LBP(CSR)	SAMSUNG	AEA4440XA	HBP(CSIR)	USA TECUMSEH
TGIM-49*	CAJ2432Z	LBP(CSR)	FRENCH TECUMSEH	AJA2425ZXA	LBP(CSR)	USA TECUMSEH

2. COMPRESSOR RELAY, OVERLOAD

MODEL	RELAY	PART NO.	OVERLOAD	PART NO.	MAKER	NOTE
TGIM-23*	22Ω-3PIN		4TM-795TFBZZ		SAMSUNG	
TGIM-49*	3ARR3*5**	-	GA3PJU00	-	TECUMSEH	

3. COMPRESSOR CAPACITOR

MODEL	STARTING	PART NO.	RUNNING	PART NO.	MAKER	NOTE
TGIM-23*	125V/125μF	30264L0200	250V/12μF	30264L0100	SAMSUNG	
TGIM-49*	160V/315μF	-	400V/30μF	-	TECUMSEH	

MAIN COMPONENTS

4. CONDENSER FAN MOTOR

MODEL	PART NAME	PART NO.	POLE	Quantity	BLADE	SIZE	MAKER
TGIM-23*	IS-4420DWSG-1	39633220410	4P	1EA	AL 4	250mm	SUNG-SHIN
TGIM-49*							

5. EVAPORATOR FAN MOTOR

MODEL	PART NAME	PART NO.	POLE	Quantity	BLADE	SIZE	MAKER
TGIM-23*	IS-4420DWSN-2A	3963328120	4P	1EA	AL 5	175mm	SUNG-SHIN
TGIM-49*				2EA			

6. EVAPORATOR DEFROST HEATER

MODEL	PART NAME	PART NO.	SPEC	MAKER
TGIM-23*	SHEATH HEATER	30228L0803	445W	SANG-DO
TGIM-49*		30228L00701	600W	

7. BALLAST & SMPS

MODEL	PART NAME	SPEC	PART NO.	QTY	MAKER
TGIM-23*	BALLAST	B232IUNVHP-B	30285R1220	1	UNIVERSAL
	SMPS	LPV-20-12(12V)	30236R2200	1	MEAN WELL
TGIM-49*	BALLAST	B232IUNVHP-B	30285R1220	1	UNIVERSAL
	SMPS	LPV-60-12(12V)	30284R0700	1	MEAN WELL

8. FLUORESCENT LAMP & LED

MODEL	PART NAME	PART NAME	PART NO.	QTY	WATT	LENGTH	BULB
TGIM-23*	Fluorescent lamp	F17T8/SP41/ECO	30236H0510	1	17W	24"	T8
	LED	19W-12V	30236R2200	1	19W	48"	-
TGIM-49*	Fluorescent lamp	TLD32W/865	30236D0511	1	32W	48"	T8
	LED	19W-12V	30236R2200	2	19W	48"	-

MAIN COMPONENTS

9. SWITCH

MODEL	TYPE	RATING	PART NO.	MAKER
TGIM-23*	LAMP SWITCH (GREEN)	125V/20A	30281R0101	SIGNAL LUX
TGIM-49*	POWER SWITCH (RED)	125V/20A	30281R0201	

10. TRANSFORMER & MAIN PCB

MODEL	PART NAME	SPEC	PART NO.	MAKER
TGIM-23*	TRANSFORMER	DWS-1310U	30284L0120	NAM-SUNG
TGIM-49*	MAIN PCB	NIF1151	30243R1000	NEUROSYS

5. MAIN PCB PROGRAMING

1. HOW TO USE THE DISPLAY PANEL

- The default temperature setting is 16°F.
- The operating temperature is between 27°F and 5°F, which can be adjusted by using the arrow key.

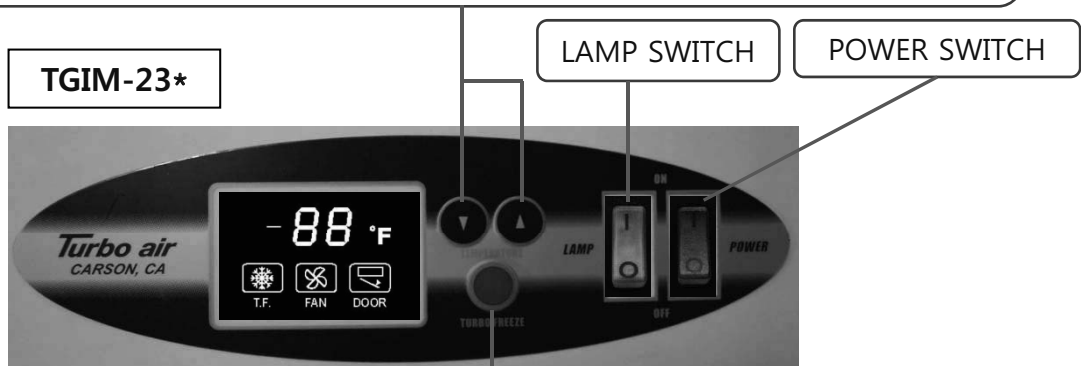

- The compressor continuously operates for 120 minutes under 'TURBO FREEZE' mode.
- Press 'TURBO FREEZE' button again to deactivate 'TURBO FREEZE' mode.



- Adjust to desired temperature setting between 27°F to 5°F with (+) and (-) buttons on the display.

MAIN PCB PROGRAMING

2. FUNCTION TABLE

No	Control Fucntion	Control Objects	Description																																																																																										
1	Initial Operation	Buzzer Fan Lamp 88 LED	<ol style="list-style-type: none"> Buzzer will be sound within 2 seconds after the power is turned on. 88 LED displays the temperature value inside the appliance. Compressor will run if evaporator's temperature is higher than 38.3°F(3.5°C). Once powered, compressor will not run for 3 minutes. If the temperature in a cooler is lower than -40°F or higher tha 99°F, 88 LED displays 'LO' or 'HI' respectively. 																																																																																										
2	Temperature Control	Compressor Evap. Fan Motor Cond. Fan Motor 88 LED	<ol style="list-style-type: none"> You can set the desired temperature from 27°F to 5°F by using the up or down arrow keys (the + or - keys). 7-segment LED will display a setting temperature when you push the up or down arrow keys (the + or - keys). 88 LED will indicate real temperature after setting the value. Buzzer will sound once whenever each button is pressed. Compressor will automatically adjust to on or off cycle, relative to the return air detection of F-sensor . Compressor will not run for 5 minutes after the off cycle even though F-sensor is in its operatinal range. Evaporator Fan Motor will run continuously except when the door is opened and the freezer is on defrost mode. Evaporator Fan Motor will run within 3 seconds after the doors are closed. Compressor On/Off Temperature(°F) <table border="1" style="width: 100%; border-collapse: collapse; text-align: center;"> <tbody> <tr> <td>Setting Value(°F)</td> <td>27</td> <td>26</td> <td>25</td> <td>24</td> <td>23</td> </tr> <tr> <td>Comp On(°F)</td> <td>30.5</td> <td>29.5</td> <td>28.5</td> <td>27.5</td> <td>26.5</td> </tr> <tr> <td>Comp Off(°F)</td> <td>23.5</td> <td>22.5</td> <td>21.5</td> <td>20.5</td> <td>19.5</td> </tr> <tr> <td>Setting Value(°F)</td> <td>23</td> <td>22</td> <td>21</td> <td>20</td> <td>19</td> </tr> <tr> <td>Comp On(°F)</td> <td>26.5</td> <td>25.5</td> <td>24.5</td> <td>23.5</td> <td>22.5</td> </tr> <tr> <td>Comp Off(°F)</td> <td>19.5</td> <td>18.5</td> <td>17.5</td> <td>16.5</td> <td>15.5</td> </tr> <tr> <td>Setting Value(°F)</td> <td>18</td> <td>17</td> <td>16</td> <td>15</td> <td>14</td> </tr> <tr> <td>Comp On(°F)</td> <td>21.5</td> <td>20.5</td> <td>19.5</td> <td>18.5</td> <td>17.5</td> </tr> <tr> <td>Comp Off(°F)</td> <td>14.5</td> <td>13.5</td> <td>12.5</td> <td>11.5</td> <td>10.5</td> </tr> <tr> <td>Setting Value(°F)</td> <td>13</td> <td>12</td> <td>11</td> <td>10</td> <td>9</td> </tr> <tr> <td>Comp On(°F)</td> <td>16.5</td> <td>15.5</td> <td>14.5</td> <td>13.5</td> <td>12.5</td> </tr> <tr> <td>Comp Off(°F)</td> <td>9.5</td> <td>8.5</td> <td>7.5</td> <td>6.5</td> <td>5.5</td> </tr> <tr> <td>Setting Value(°F)</td> <td>8</td> <td>7</td> <td>6</td> <td>5</td> <td></td> </tr> <tr> <td>Comp On(°F)</td> <td>11.5</td> <td>10.5</td> <td>9.5</td> <td>8.5</td> <td></td> </tr> <tr> <td>Comp Off(°F)</td> <td>4.5</td> <td>3.5</td> <td>2.5</td> <td>1.5</td> <td></td> </tr> </tbody> </table>	Setting Value(°F)	27	26	25	24	23	Comp On(°F)	30.5	29.5	28.5	27.5	26.5	Comp Off(°F)	23.5	22.5	21.5	20.5	19.5	Setting Value(°F)	23	22	21	20	19	Comp On(°F)	26.5	25.5	24.5	23.5	22.5	Comp Off(°F)	19.5	18.5	17.5	16.5	15.5	Setting Value(°F)	18	17	16	15	14	Comp On(°F)	21.5	20.5	19.5	18.5	17.5	Comp Off(°F)	14.5	13.5	12.5	11.5	10.5	Setting Value(°F)	13	12	11	10	9	Comp On(°F)	16.5	15.5	14.5	13.5	12.5	Comp Off(°F)	9.5	8.5	7.5	6.5	5.5	Setting Value(°F)	8	7	6	5		Comp On(°F)	11.5	10.5	9.5	8.5		Comp Off(°F)	4.5	3.5	2.5	1.5	
Setting Value(°F)	27	26	25	24	23																																																																																								
Comp On(°F)	30.5	29.5	28.5	27.5	26.5																																																																																								
Comp Off(°F)	23.5	22.5	21.5	20.5	19.5																																																																																								
Setting Value(°F)	23	22	21	20	19																																																																																								
Comp On(°F)	26.5	25.5	24.5	23.5	22.5																																																																																								
Comp Off(°F)	19.5	18.5	17.5	16.5	15.5																																																																																								
Setting Value(°F)	18	17	16	15	14																																																																																								
Comp On(°F)	21.5	20.5	19.5	18.5	17.5																																																																																								
Comp Off(°F)	14.5	13.5	12.5	11.5	10.5																																																																																								
Setting Value(°F)	13	12	11	10	9																																																																																								
Comp On(°F)	16.5	15.5	14.5	13.5	12.5																																																																																								
Comp Off(°F)	9.5	8.5	7.5	6.5	5.5																																																																																								
Setting Value(°F)	8	7	6	5																																																																																									
Comp On(°F)	11.5	10.5	9.5	8.5																																																																																									
Comp Off(°F)	4.5	3.5	2.5	1.5																																																																																									
3	Turbo Freeze	Compressor Evap. Fan Motor Cond. Fan Motor 88 LED	<ol style="list-style-type: none"> If the 'Turbo Freeze' button is pressed, the 'Turbo Freeze' mode will start. If the 'Turbo Freeze' button is pressed again during 'Turbo Freeze' mode, the turbo freeze mode will be cancelled. 'TURBO FREEZE' mode activates uninterrupted decrease in temperature; the arrow keys will not be operational. 88 LED will continuously flash 'T.F.' during 'Turbo Freeze' mode. The compressor & condenser fan motor will operate for 120 minutes. 																																																																																										

MAIN PCB PROGRAMING

No	Control Fucntion	Control Objects	Description																														
3	Turbo Freeze	Compressor Evap. Fan Motor Cond. Fan Motor 88 LED	<p>6. If the 'Turbo Freeze' button is pressed under defrost mode, 88 LED will flash 'T.F'; however, 'Turbo Freeze' mode will start after defrost mode is terminated.</p> <p>7. If defrost mode occurs during 'Turbo Freeze' mode, the defrost mode will start after the turbo freeze mode is terminated.</p>																														
4	Determination of Defrost		<p>1. Defrost mode will initiate under the following condition:</p> <p>2. Make sure 6 hours have passed since the last defrost mode was terminated.</p> <ul style="list-style-type: none"> - F sensor ERROR - Defrost sensor ERROR - Door sensor ERROR - 14 hours have passed since last defrost mode was terminated. - Doors have been open for more than 10 minutes. - Compressor has been running for more than 85% of the time. <p>3. If defrost mode does not initiate under errors described above, it will also trigger if:</p> <ul style="list-style-type: none"> - Compressor has been operating for more than 6 hours. <p>4. where, the defrost period is 6 hours when the appliance is initially powered up.</p>																														
5	Defrost Function	Heater Compressor Evap. Fan Motor Cond. Fan Motor	<p>1. Defrost Step</p> <table border="1" style="width: 100%; border-collapse: collapse; text-align: center;"> <thead> <tr> <th></th> <th>Pre-cool</th> <th>Heater</th> <th>Pause</th> <th>Fan Delay</th> </tr> </thead> <tbody> <tr> <td>Comp</td> <td>on</td> <td>off</td> <td>off</td> <td>on</td> </tr> <tr> <td>E-fan motor</td> <td>on</td> <td>off</td> <td>off</td> <td>off</td> </tr> <tr> <td>C-fan motor</td> <td>on</td> <td>off</td> <td>off</td> <td>on</td> </tr> <tr> <td>Heater</td> <td>off</td> <td>on</td> <td>off</td> <td>off</td> </tr> <tr> <td>Max time</td> <td>15min</td> <td>30min</td> <td>5min</td> <td>5min</td> </tr> </tbody> </table> <p>A. Pre-cool step</p> <ol style="list-style-type: none"> a. It prevents from excessive high temperature during defrost mode. b. Compressor, condenser fan motor and evaporator fan motor will run continuously during the pre-cool step. c. 88 LED shows the temperature inside the cabinet. d. If F-sensor temperature is lower than -16°F or maximum time of pre-cool step interval for 15 minutes, the pre-cool step will turn off. e. 'Turbo Freeze' mode is enabled just once during pre-cool step. <p>B. Heater defrost step</p> <ol style="list-style-type: none"> a. To minimize the risk of icing up, the defrost heater will run periodically. b. 88 LED display 'dF' when the defrost heater is energized. c. The defrost heater will stop running if the temperature of D-sensor rises above 43°F(6°C) or exceeds a maximum running time, 30 minutes. d. If D-sensor temperature does not reach 43°F in 30 minutes, error code will be shown on LED display panel. 		Pre-cool	Heater	Pause	Fan Delay	Comp	on	off	off	on	E-fan motor	on	off	off	off	C-fan motor	on	off	off	on	Heater	off	on	off	off	Max time	15min	30min	5min	5min
	Pre-cool	Heater	Pause	Fan Delay																													
Comp	on	off	off	on																													
E-fan motor	on	off	off	off																													
C-fan motor	on	off	off	on																													
Heater	off	on	off	off																													
Max time	15min	30min	5min	5min																													

MAIN PCB PROGRAMING

No	Control Function	Control Objects	Description
5	Defrost Function	Heater Compressor Evap. Fan Motor Cond. Fan Motor	<p>C. Pause step</p> <p>a. To ensure that refrigeration system has the time to be stabilized, please allow compressor and fan motors to have enough rest time after heater defrost mode is deactivated.</p> <p>b. Time = 5 min, LED Display panel will be shown as 'dF'.</p> <p>D. Fan delay step</p> <p>a. Max. Time = 5 min</p> <p>b. Only Comp. is ON.</p> <p>c. If D-sensor temperature goes down under 14°F in 5 minutes, evaporator fan motor will turn on immediately.</p>
6	Manual Defrost	Heater Compressor Evap. Fan Motor Cond. Fan Motor	<p>A. 1. Press the both up/down (or +/-) keys for 5 seconds. 88 LED should display "SL".</p> <p>2. Press the down(or -) button. 88 LED display "dS".</p> <p>3. Press the down(or -) button. 88 LED display "dF" and defrost mode start.</p> <p>B. On manual defrost mode</p> <p>1. The pre-cool step is omitted.</p> <p>2. Heater defrost step is run.</p> <p>3. The next procedure is the same as that of defrost mode.</p>
7	Fuzzy Defrost	Heater Compressor Evap. Fan Motor Cond. Fan Motor	<p>The defrost cycle will start during conditions as specified below.</p> <p>A. The compressor has run for 30 minutes.</p> <p>B. There is no door open for 30 minutes.</p> <p>C. The temperature of D-sensor is lower than 5°F.</p> <p>D. The temperature of F-sensor is higher than D-sensor's temperature by 32°F for 10 minutes.</p>
8	Comp Restart Prevent	Compressor Cond. Fan Motor	<p>A. Compressor will not run for 5 minutes after off cycle even if F-sensor is in its operational range.</p>
9	Power Failure Back up Function	Compressor Evap. Fan Motor Cond. Fan Motor	<p>A. Compressor will not be run for 5 minutes after power failure.</p> <p>B. Only Evap. Fan Motor is ON.</p>
10	Door Open Alarm Function	Buzzer 88 LED	<p>A. The LED Display panel will read 'DOOR' icon and will not flash 'FAN' icon.</p> <p>B. Before sounding the beeper:</p> <p>1. Door was open for more than 30 seconds, the buzzer will sound 3 times.</p> <p>2. Door was open for more than 60 seconds, the buzzer will sound 5 times.</p> <p>3. Door was open for more than 5 minutes, the buzzer will continuously sound.</p>
11	Buzzer Function	Buzzer	<p>A. Beep sound rings once after initial power up.</p> <p>B. Beep sound rings whenever each button is pressed.</p> <p>C. If the door stays open past a certain amount of time, beeping will occur. (see door open alarm function)</p>

MAIN PCB PROGRAMING

3. FUNCTION MODE(Manual defrost, Error display, Model change. etc.)

3-1) Enter the Function mode

- ▶ Press the both up/down (or +/-) buttons at the same time for 5 seconds.
88 LED display "SL".

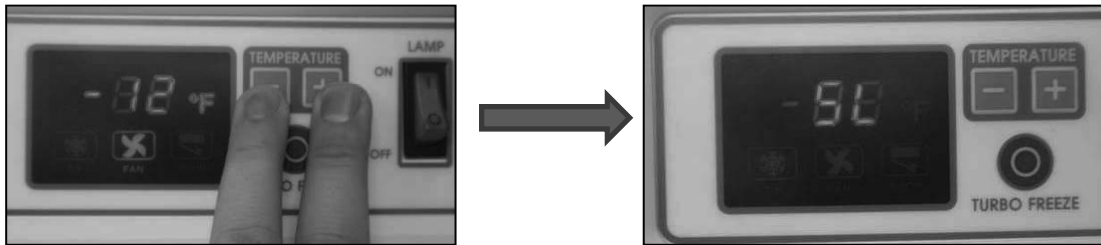

3-2) Manual Defrost Mode

- ▶ initiate the manual defrost function by pressing the down (-) button once while displaying SL on the display. Then, the display will show 'dS'.
- ▶ if the down (-) button is pressed again while displaying 'dS', it will display 'dF' and it is in manual defrost mode.
- ▶ Repeat the procedure to terminate the manual defrost.

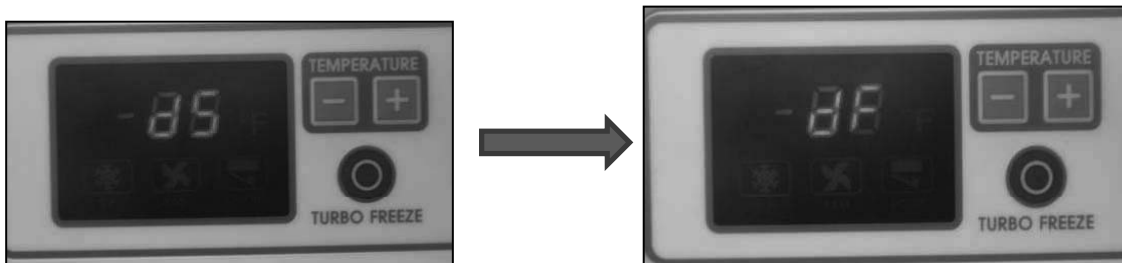

3-3) Error display Mode

- ▶ Press the down (-) button 4 times while displaying 'SL' on the display.
If there is no error in the memory, display will show 'no'.

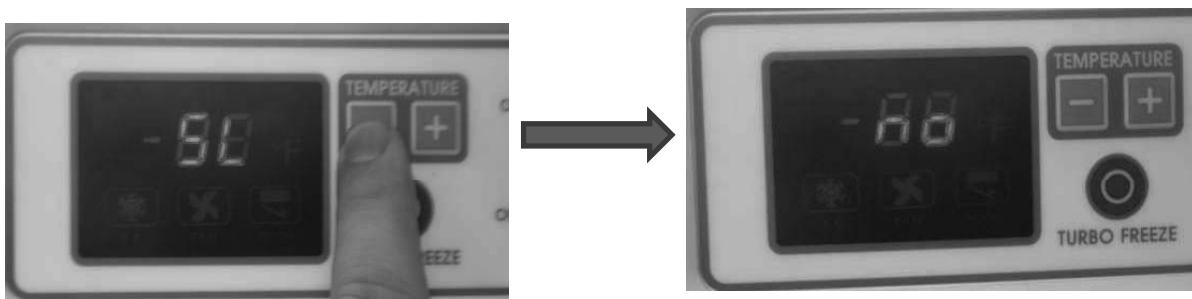

MAIN PCB PROGRAMING

Code	Content	Perception Method	Freezer Operation State
F1	F-sensor Malfunction	- Sensor shorted.	- The compressor runs for 30 minutes and stops for 5 minutes repeatedly.
F0		- Sensor disconnected.	
D1	D-sensor Malfunction	- Sensor shorted	- Defrost heater may operate it. - If F-sensor temperature is higher than 28.4°F, the heater goes off.
D0		- Sensor disconnected	- Defrost heater turns on for 20 minutes if F-sensor is in error mode too.
C1	Cycle, Comp. Malfunction	- The temperature of D-sensor is over 32°F even though the compressor has been running for 30 minutes.	- Normal operation (Compressor is automatically turned on and off by F-sensor.)
F3	Defrost Malfunction	- The temperature of D-sensor doesn't reach 43°F within 30 minutes.	- Defrost heater will be on every time for 30 minutes. - If the D-sensor's temp. reaches 43°F within 30 minutes, defrost heater will be turned off immediately.

3-4) Change the Model

- ▶ Press the down (or -) keys five times during 88 LED displaying "SL", 88 LED display Present Model Number. If the number is not "5" you have to change the model number. (Next Five Model is controlled by the same PCB ASSY)

MODEL	Top Mount Refrigerator	Top Mount Freezer	Bottom Mount Refrigerator	Bottom Mount Freezer	Glass Door Freezer	ICE Merchandiser
		TRF-****	TFF-****	TSR-****	TSF-****	TGF-****
Number	0	1	2	3	4	5

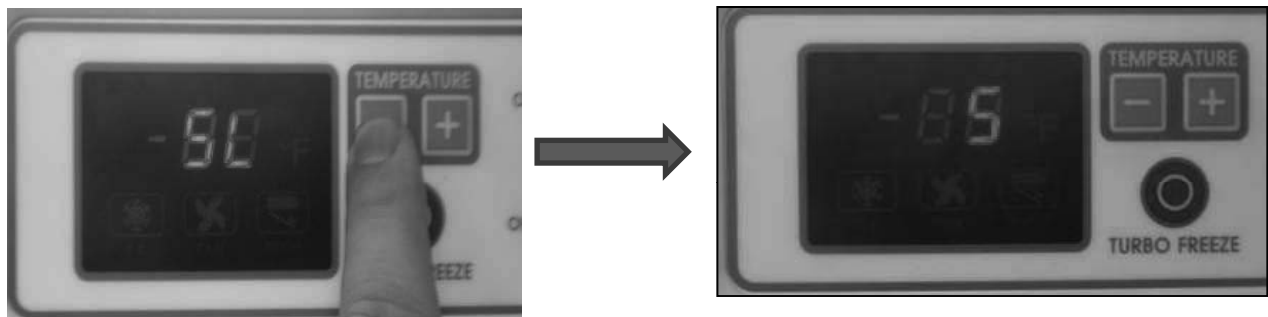

6. PARTS LIST

Part Name	Part Number	Description	Model	
			TGIM 23	TGIM 49
ADJUSTABLE FEET BOLT				
ADJUSTABLE FEET BOLT	30206K0100	1/2" 28mm	4	4
Compressor				
Compressor	30200Q1200	SK1A1C-L2W(115V/60Hz)	1	
Compressor	30200R1000	CAJ2432Z		1
Compressor Relay	-	J531Q34E22OM3503	1	
Compressor Overload	-	4TM 795TFBZZ-53	1	
Compressor Run Capacitor	30264L0100	250V/12 μ F	1	
Compressor Start Capacitor	30264L0200	125V/125 μ F	1	
Power Relay	30281H0350	GMC-30P2 (110V)	1	1
Main Power Cord	30213A1014	KKP-30B(탈피)	1	1
Condenser				
Condenser Coil	30200L4002	CU+AL	1	
Condenser Coil	30200L4305	CU+AL		1
Condenser Fan Motor	3963320410	IS-4420DWSG-1	1	1
Condenser Fan Motor Blade	30218A0300	AL 5 (Φ250mm)	1	1
Dryer	30268Q0300	C-052-S	1	1
COVER MACH-RM	30214Q5000	Wire	1	
COVER MACH-RM	30278Q0410	Wire		1
Evaporator				
Evaporator Coil	30270R0500	Cu + AL	1	
Evaporator Coil	30270L0606	Cu + AL		1

PARTS LIST

Part Name	Part Number	Description	Model	
			TGIM 23	TGIM 49
Evaporator Sensor	30227Q1210	F-D Sensor	1	1
Evaporator Thermal Fuse	30272L0401	PST-3(80°C/10°C)	1	1
Evaporator Defrost Heater	30228L0803	445W(Sheath Heater)	1	
Evaporator Defrost Heater	30228L0701	600W(Sheath Heater)		1
Evaporator Drain Pan Heater	30228L1400	90W	1	
Evaporator Drain Pan Heater	30228L1500	90W		1
Evaporator Drain Hose Heater	30228L1380	10W	1	1
Evaporator Fan Motor Guard	30214K0100	HIPS	1	2
Evaporator Fan Motor Blade	30218F0200	AL Φ175	1	2
Evaporator Fan Motor	3963328122	IS-4420DWSN-2A	1	2
Door				
Door Assembly	30200R1500	Heated Glass	1	
Door Assembly	30200R3500	Heated Glass Right		1
Door Assembly	30200R3600	Heated Glass Left		1
Door Glass	30255R0200	T24, Right	1	1
Door Glass	30255R0300	T24, Left		1
Door Gasket	30223R0201	PVC-S, 1345×650	1	2
Door Handle	30226G0101	Zn, Dycasting	1	2
Sign Panel				
Ballast	30285R1220	B232I120RH-A (17W or 32W)	1	1
Lamp	30236D0511	TLD32W/865 (32W)		1
Lamp	30236H0510	F17T8/SP41/ECO (17W)	1	
Lamp Holder	3183005000	SK-10, OD28	1	1
Lamp Socket	30227R1001	Including Harness	1	
Lamp Socket	30227R2400	Including Harness		1
Lamp Switch	30281R0301	125V/20A (Green)	1	1
Power Switch	30281R0201	125V/20A (Red)	1	1

PARTS LIST

Part Name	Part Number	Description	Model	
			TGIM 23	TGIM 49
Sign Panel	P0145A1200	PC	1	
Sign Panel	P0145A1300	PC		1
Sign Frame *Left	30222A2400	ABS	1	
Sign Frame *Right	30222A2500	ABS	1	
Sign Frame *Left	30222R2200	ABS		1
Sign Frame *Right	30222R2300	ABS		1
Bottom Grille				
Bottom Grill	30224R0103	ABS	1	
Bottom Grill	30200R3400	White Painting		1
Thermostat & PCB				
Main PCB	30243R0400	NGF1151	1	1
Display PCB	30242R0100	Display	1	1
Transformer	30284L0100	DWS-115U	1	1
BI-METAL THERMOSTAT	30272L0401	DWS-115U	1	1
Shelf				
Shelf(U)	30278R0500	Wire, White	1	
Shelf(U)	30278Q0300	Wire, White (Right)		2
Shelf(F)	30278R0400	Wire, White (Left)	1	
Shelf(F)	30278R0520	Wire, White		2
Shelf	30278R0600	Stainless Steel	3	
Shelf	30278R0400	PA-6		6
Shelf(B)	30278R0700		1	2
LED & SMPS				
LED	30236R2200	LED LAMP 19W	1	2
SMPS	30284R0500	LPV-20-12	1	
SMPS	30284R0700	LPV-60-12		1
COVER LAMP	30214R1020	EGI+WHITE PAINT	1	
LED BKT COVER *T	30214Q3500	EGI+WHITE PAINT		1
LED BRACKET *L	30206Q1010	EGI+WHITE PAINT		1
LED BRACKET *R	30206Q1000	EGI+WHITE PAINT		1

7. REPLACEMENT OF MAIN COMPONENTS

1. TGIM-23*

1-1. BOTTOM GRILLE PARTS

- MAIN PCB, TRANSFORMER, POWER RELAY
- DISPLAY PCB
- LAMP SWITCH, POWER SWITCH

A. Remove the 4 screws and detach the bottom grille.



B. Remove the Bracket of Display PCB



REPLACEMENT OF MAIN COMPONENTS

C . Remove the Electrical Box Cover.

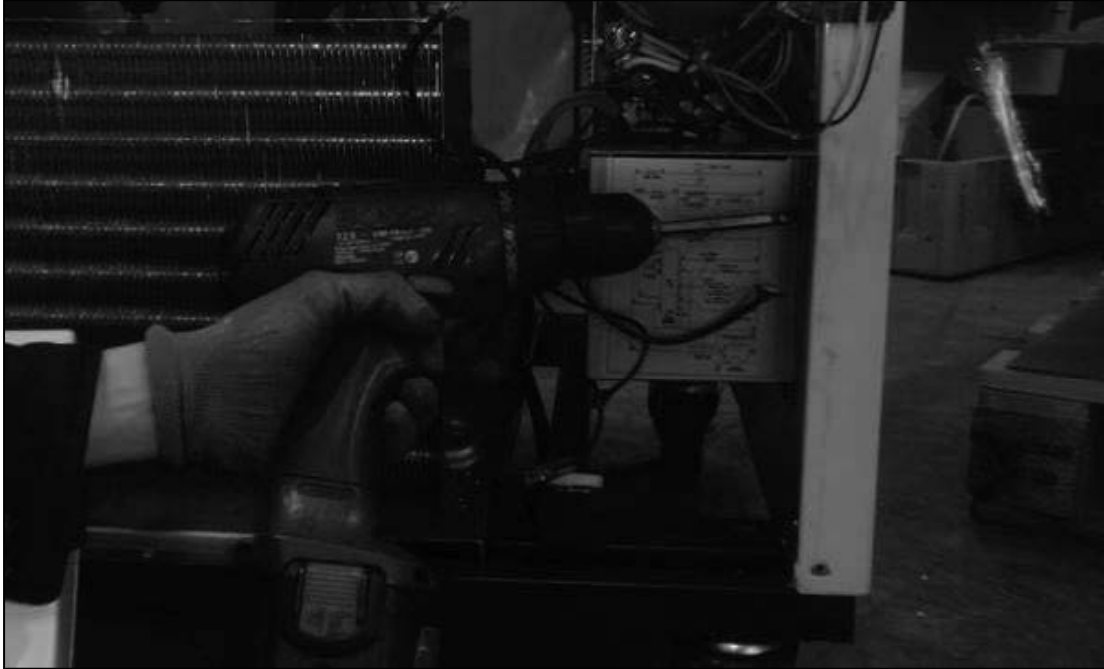

REPLACEMENT OF MAIN COMPONENTS

D. Replace the Main PCB, Transformer, and Magnetic contactor.

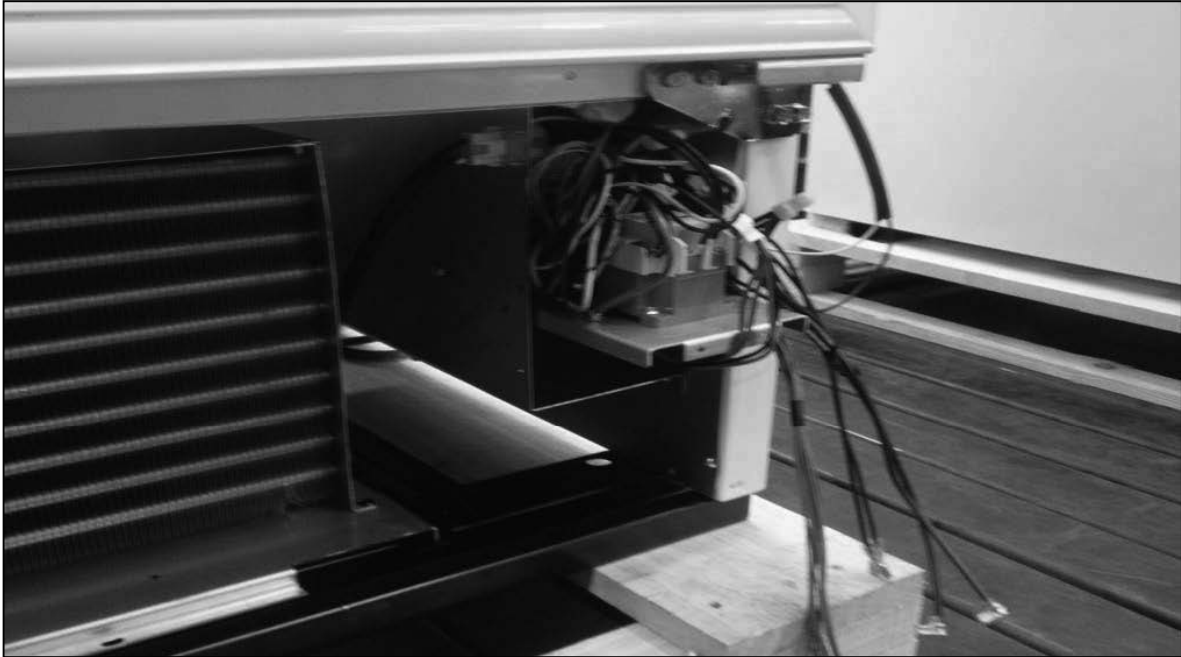

E. Replace the SMPS

- . LED ballast (SMPS) is located on the other side of the main PCB base.



REPLACEMENT OF MAIN COMPONENTS

1-2 REPLACE THE DOOR

- A. Disassemble bottom grille as described section 7-1, A,B,C,D**
- B. Disconnect the door heater and lamp wire.**

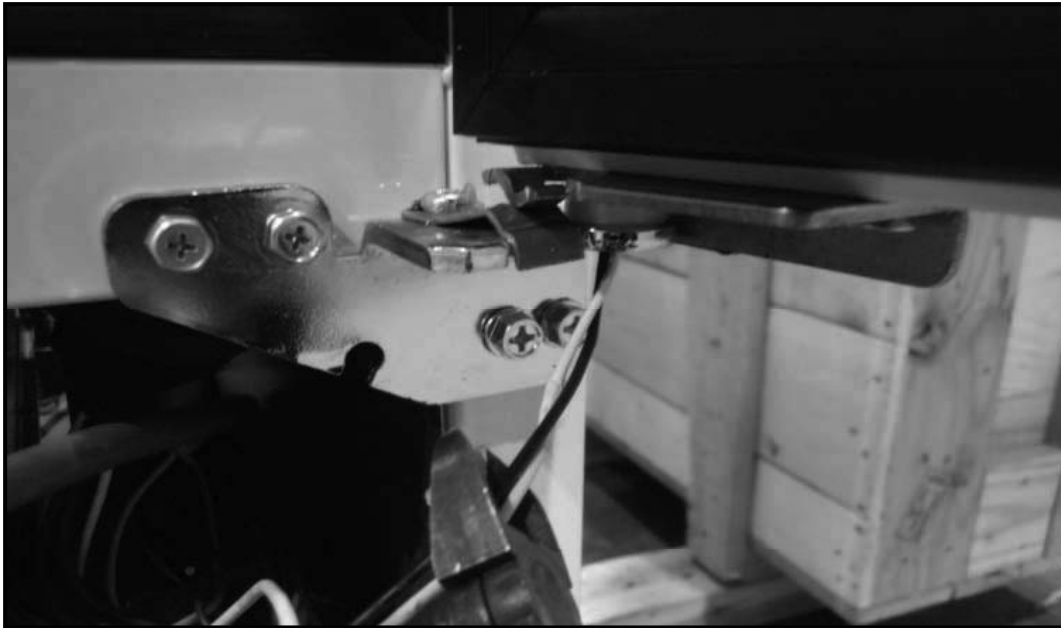

- C. Remove the Sign Frame(Left, Right) by unscrewing the four screws of each side.**



REPLACEMENT OF MAIN COMPONENTS

D. Pull out sign panel to the Right side.



E. Remove the bottom sign panel frame.

- Replace the Ballast (Sign Panel)

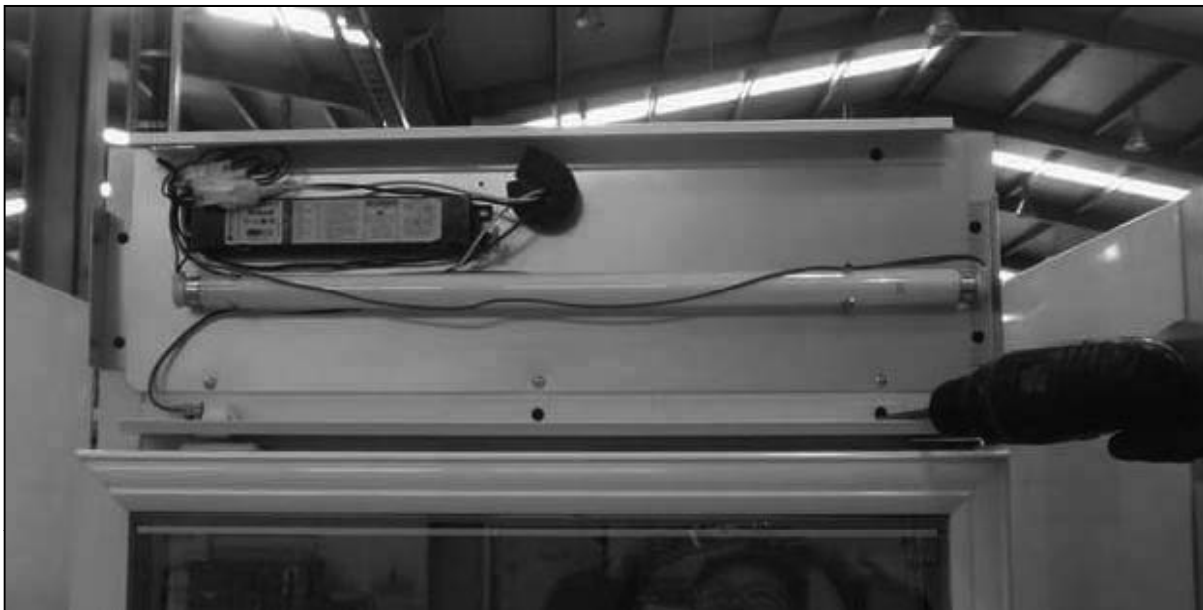

REPLACEMENT OF MAIN COMPONENTS

F. Remove the harness of door switch.

- Replace door Switch.

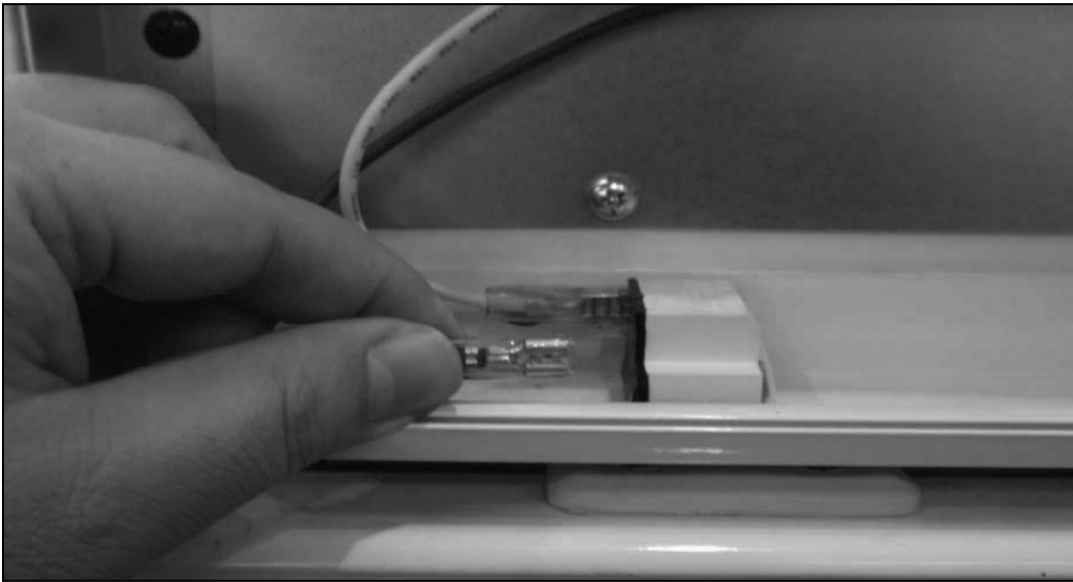

G. Remove the top hinge.

H. Lift up the door and pull out the heater wire at the same time.

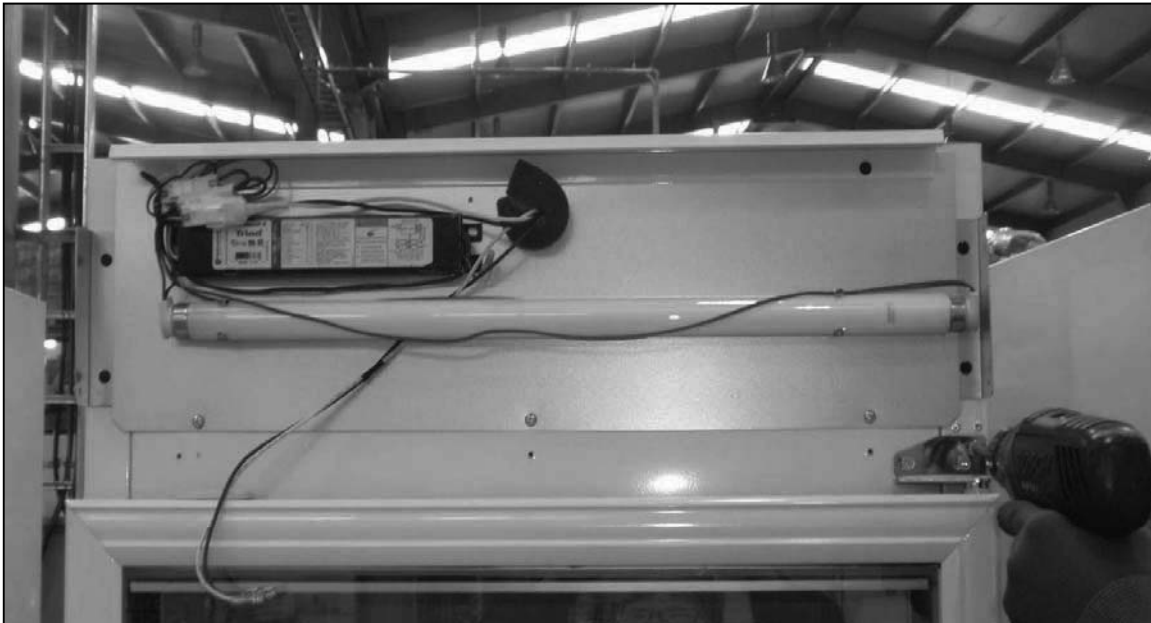

REPLACEMENT OF MAIN COMPONENTS

2. TGIM-49*

2-1. BOTTOM GRILL PARTS

- Condensing Unit, Ballast. Power Relay

A. Remove Bottom Grill by unscrewing the four screws.



B. Disconnect Connector to replace the condensing unit.



REPLACEMENT OF MAIN COMPONENTS

C. Remove two screws from the base of condensing unit.

1. Pull out the Condensing Unit.
2. Replace the Parts.

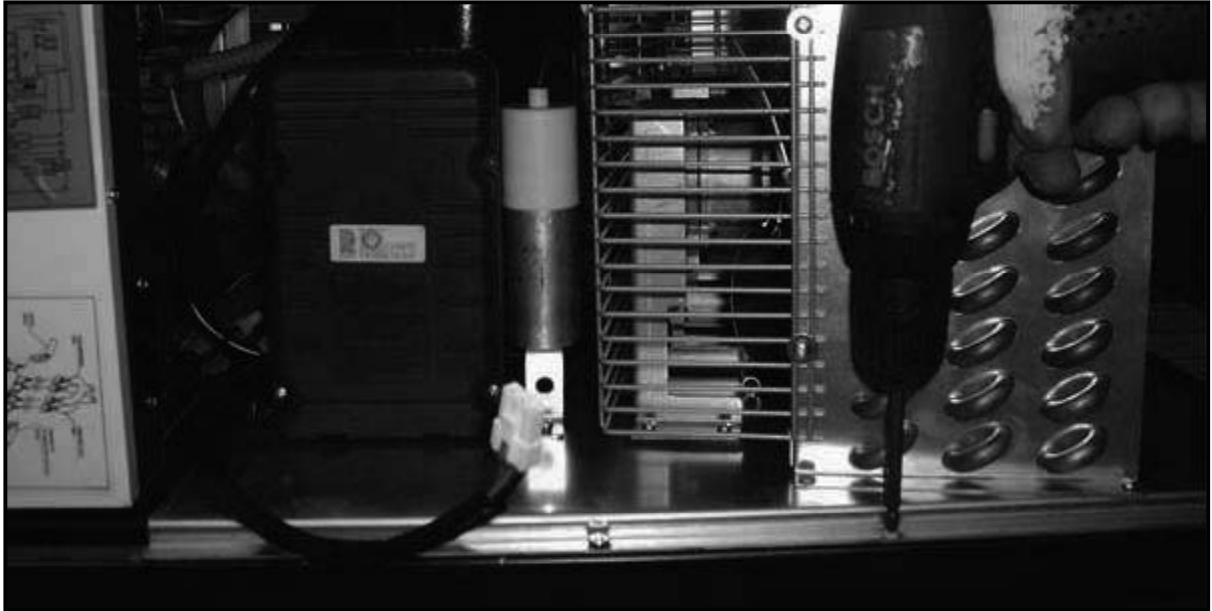

D. Slide out the Condensing Unit to replace the fan motor and the compressor.



REPLACEMENT OF MAIN COMPONENTS

E. Remove one screw from each side and remove the wire junction box cover.

* Replace the magnetic contactor.

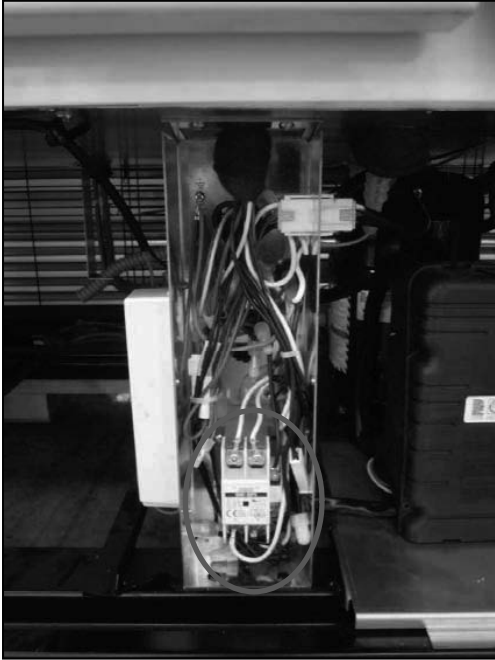

F. Disconnect connector to replace the SMPS

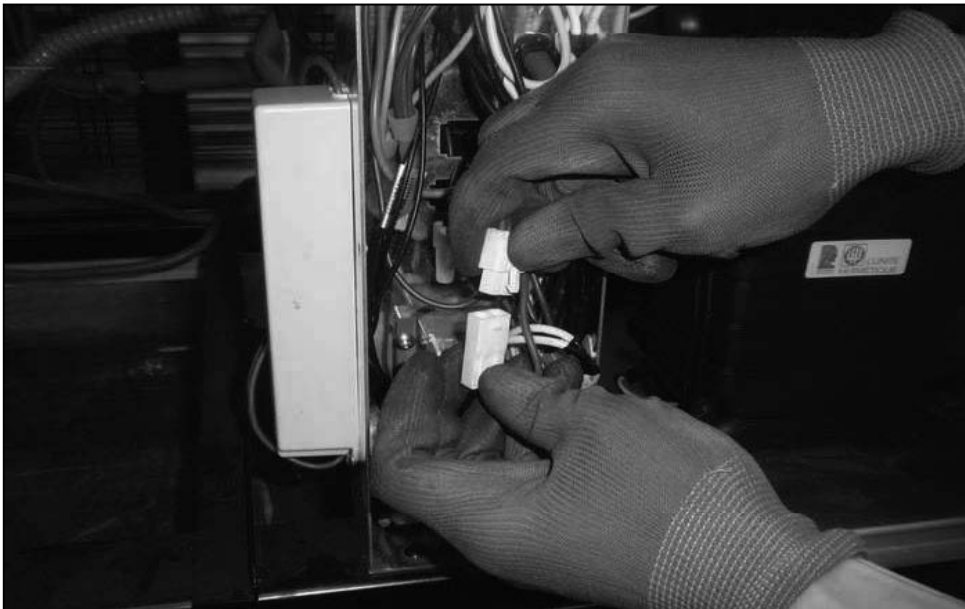

REPLACEMENT OF MAIN COMPONENTS

G. Replace the SMPS



REPLACEMENT OF MAIN COMPONENTS

2-2. Parts inside the top sign panel

- PCB, TRANSFORMER, BALLAST, POWER SWITCH, LAMP SWITCH

A. Remove two screws from the side bracket.



B. Slide out the sign panel.

- Replace the parts



REPLACEMENT OF MAIN COMPONENTS

C. Remove the display panel.

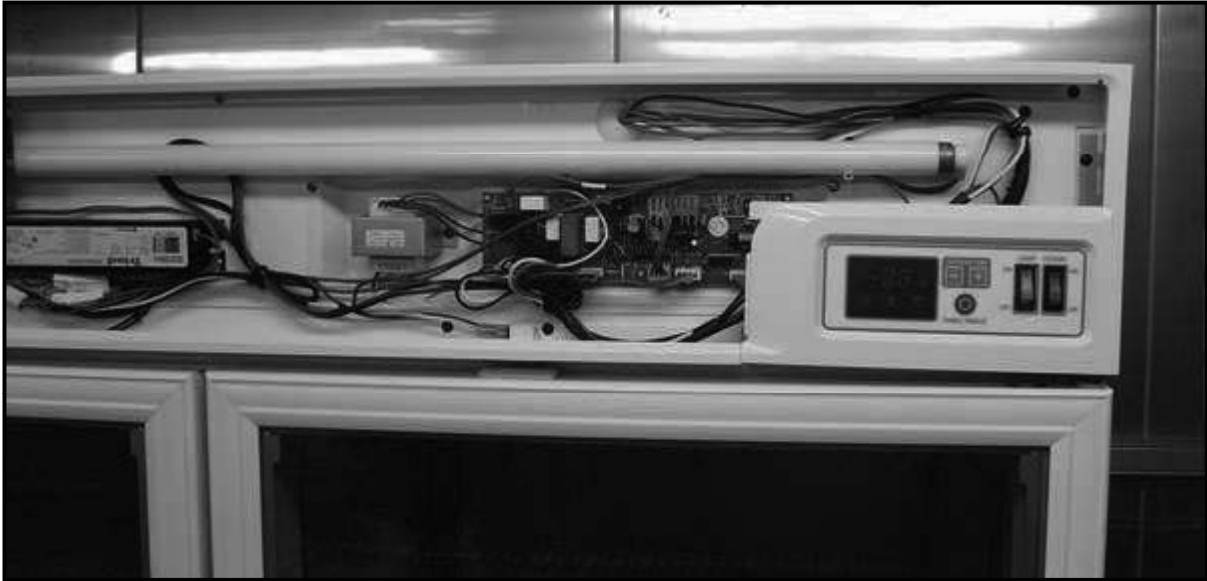

D. Replace parts as needed (Display board, Power switch, Lamp switch)

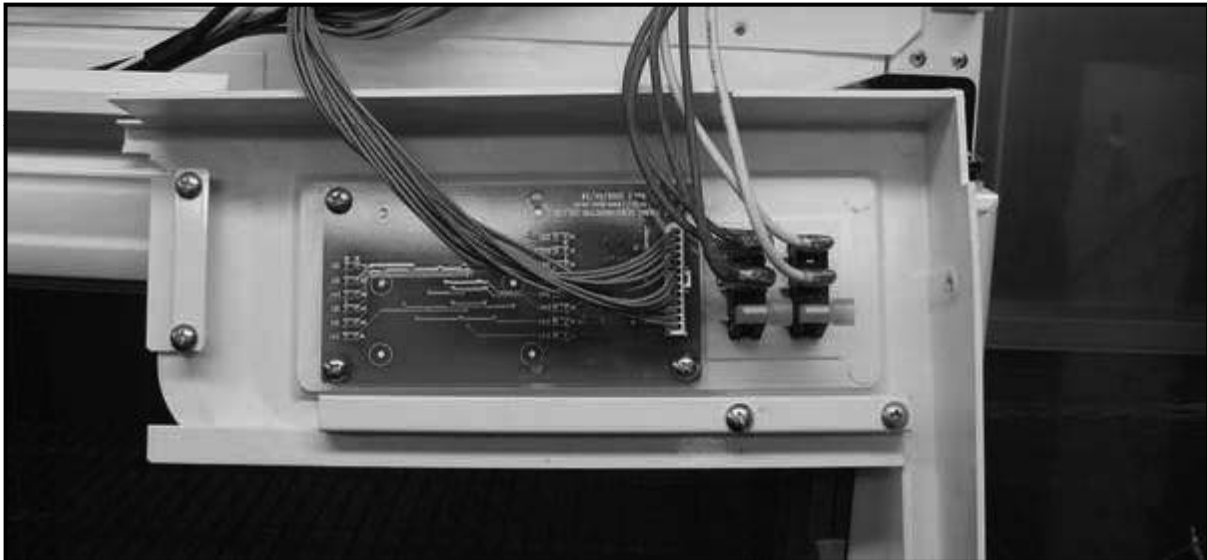

REPLACEMENT OF MAIN COMPONENTS

2-3. Replace the Door

A. Disconnect the door heater wire in the wire junction box.

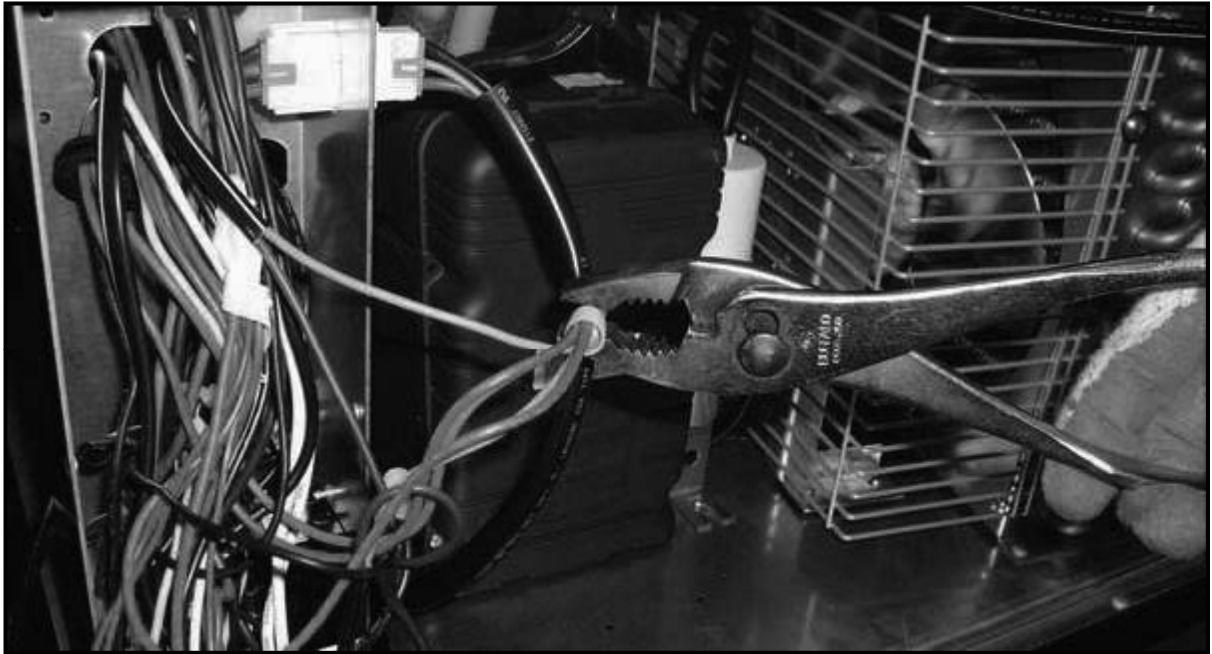

B. Remove the top hinge.

C. Lift up the door and pull out the heater wire at the same time..

