

REFRIGERATOR MANUFACTURER
Turbo air

**SUPER DELUXE
REFRIGERATOR
& FREEZER
SERVICE MANUAL**

Model No.

SD REFRIGERATOR

TGM-5SD*

TGM-7SD*

TGM-10SD*

TGM-12SD*

TGM-15SD*

TGM-20SD*

TGM-23SD*

TGM-35SD*

TGM-47SD*

TGM-72SD*

SD FREEZER

TGF-5SD*

TGF-10SD*

TGF-15SD*

TGF-23SD*

TGF-35SD*

TGF-47SD*

TGF-72SD*

TABLE OF CONTENTS

1. FEATURE CHART

2. PART DETAILS

3. WIRING DIAGRAM

4. SPECIFICATION OF MAIN COMPONENTS

5. MAIN PCB PROGRAMING

6. PARTS LIST

7. REPLACEMENT OF MAIN COMPONENTS

7-1. TGM-5SD*, TGM-7SD*, TGF-5SD*

7-2. TGM-10SD*, TGM-12SD*, TGF-10SD*

7-3. TGM-15SD*, TGM-20SD*, TGM-23SD*, TGF-15SD*, TGF-23SD*

7-4. TGM-35SD*, TGM-47SD*, TGM-72SD*, TGF-35SD*, TGF-47SD*, TGF-72SD*

1. FEATURE CHART

1-1. TGM-5SD*, TGM-7SD*, TGF-5SD*

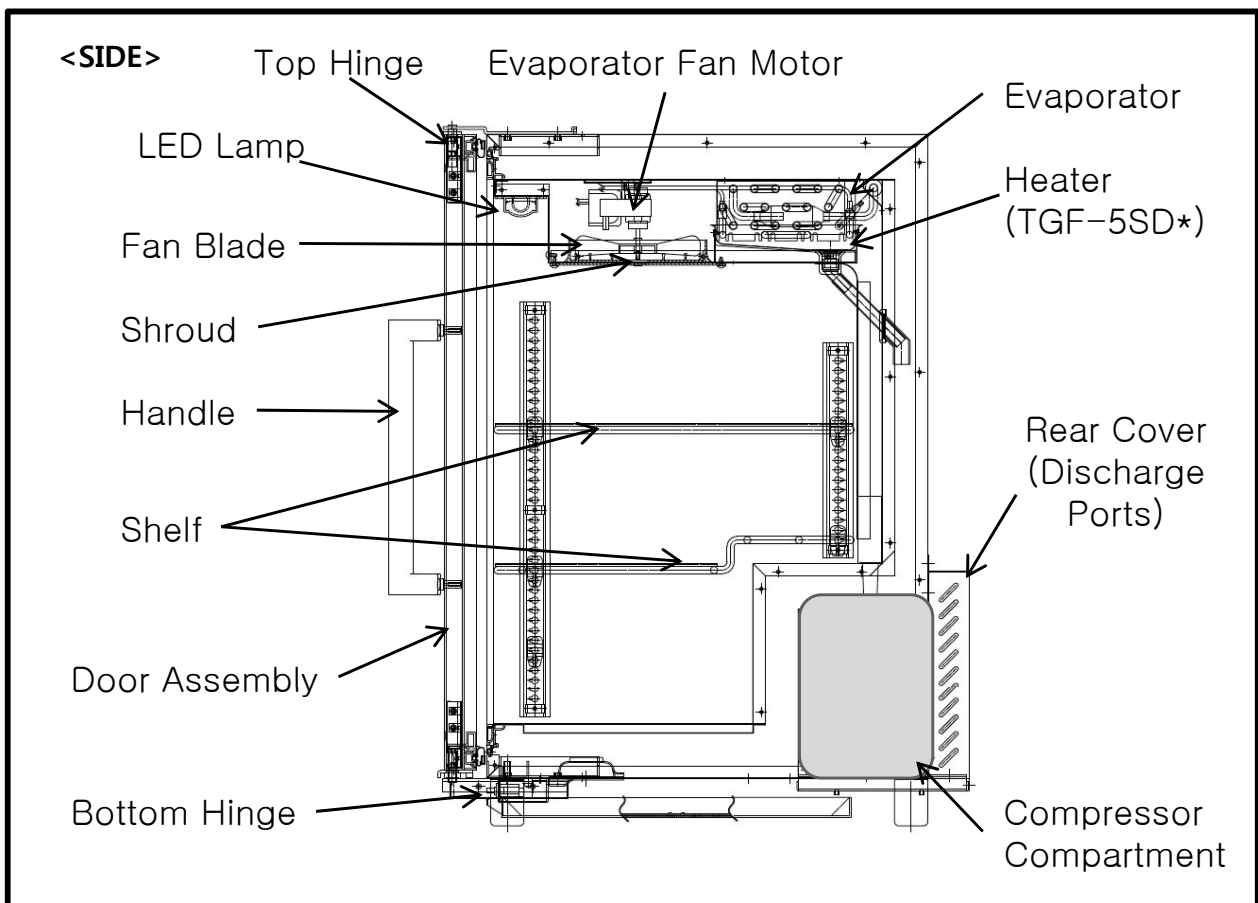
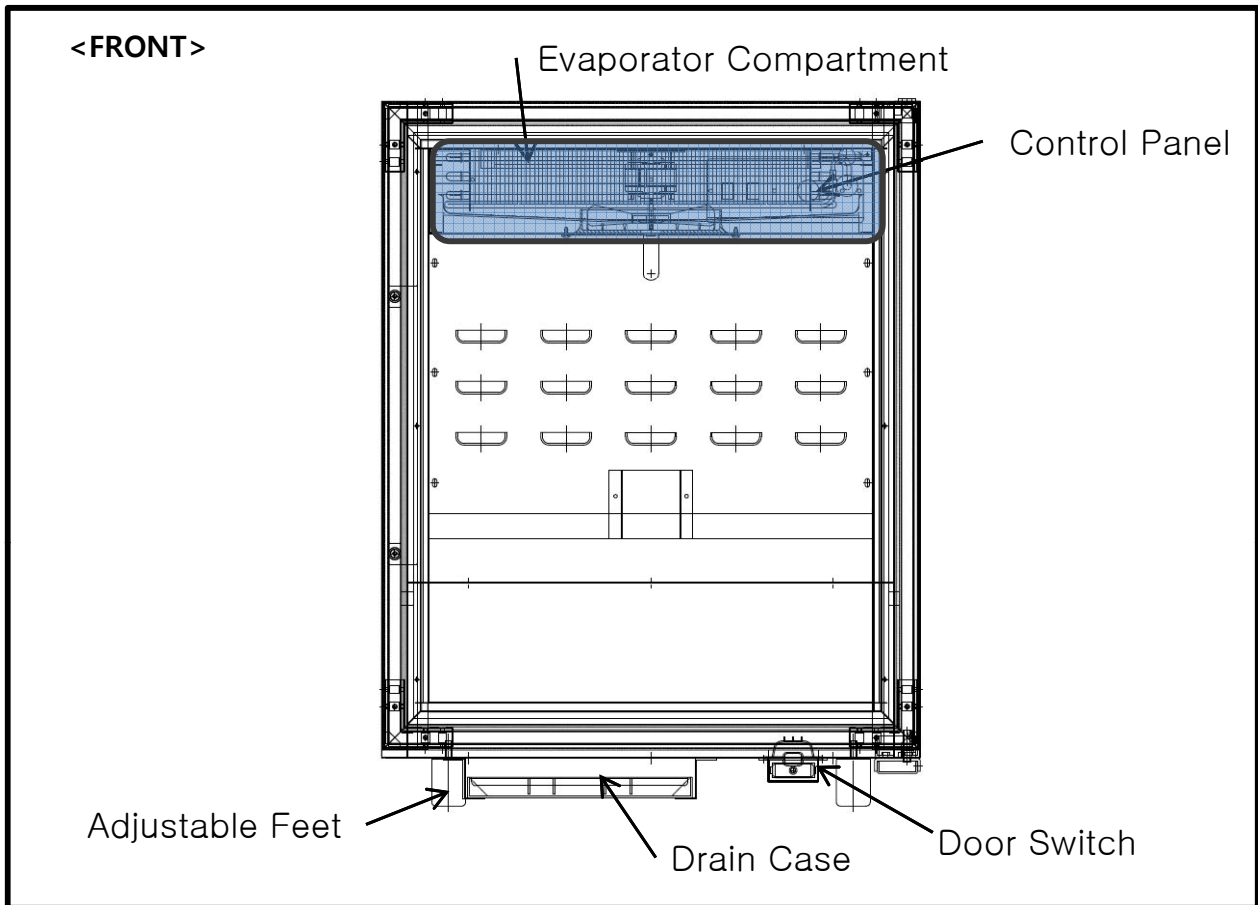

FEATURE CHART

1-2. TGM-10SD*, TGM-12SD*, TGF-10SD*

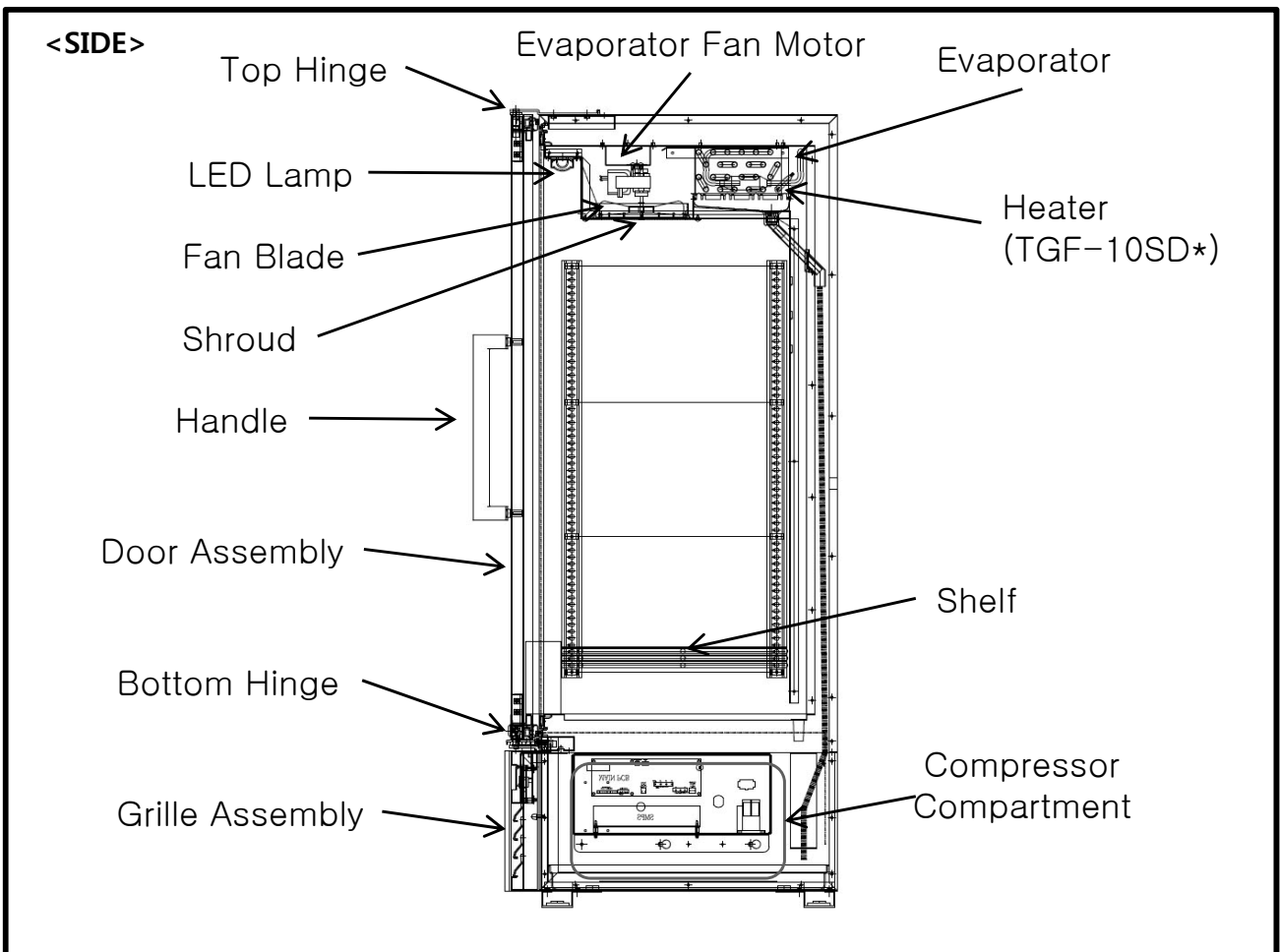
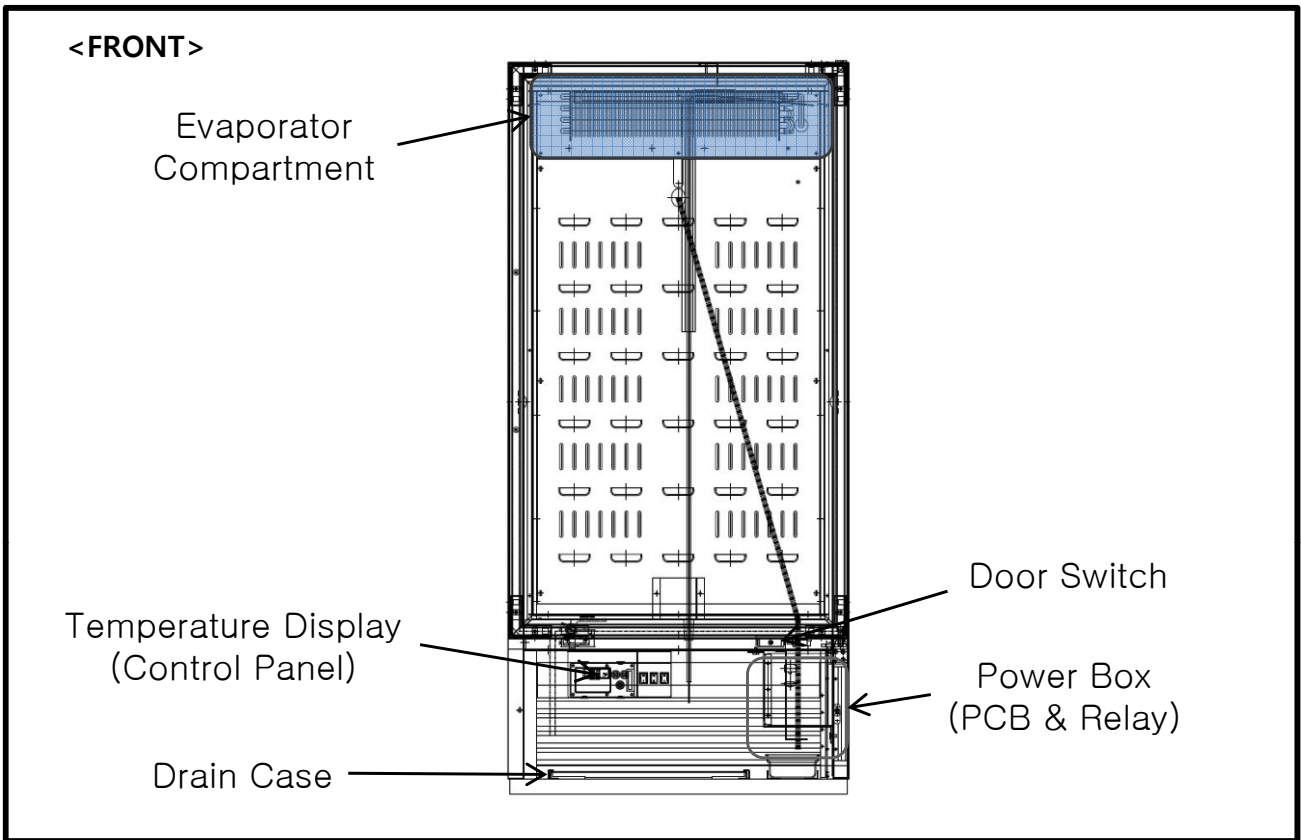

FEATURE CHART

1-3. TGM-15SD*, TGM-20SD*, TGM-23SD*, TGF-15SD*, TGF-23SD*

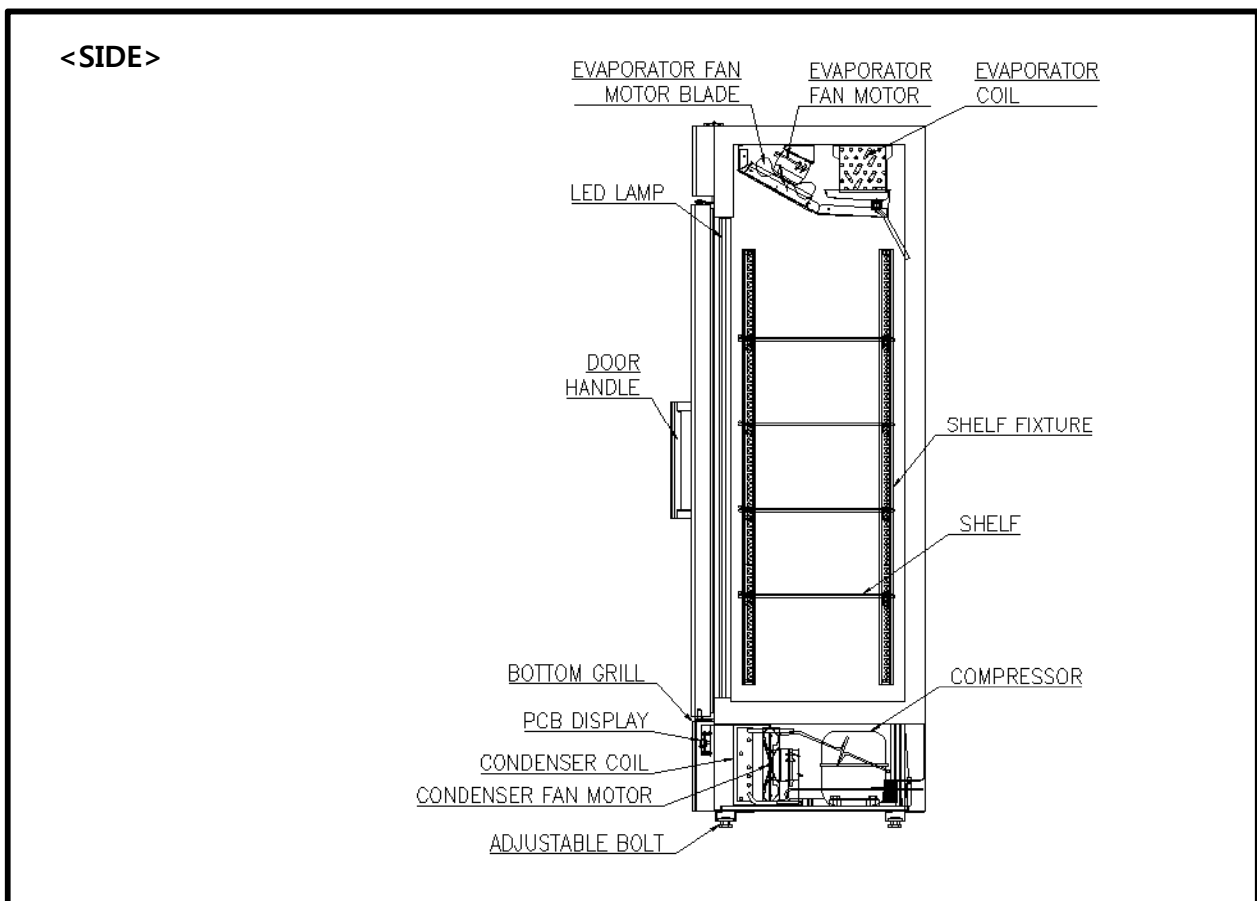
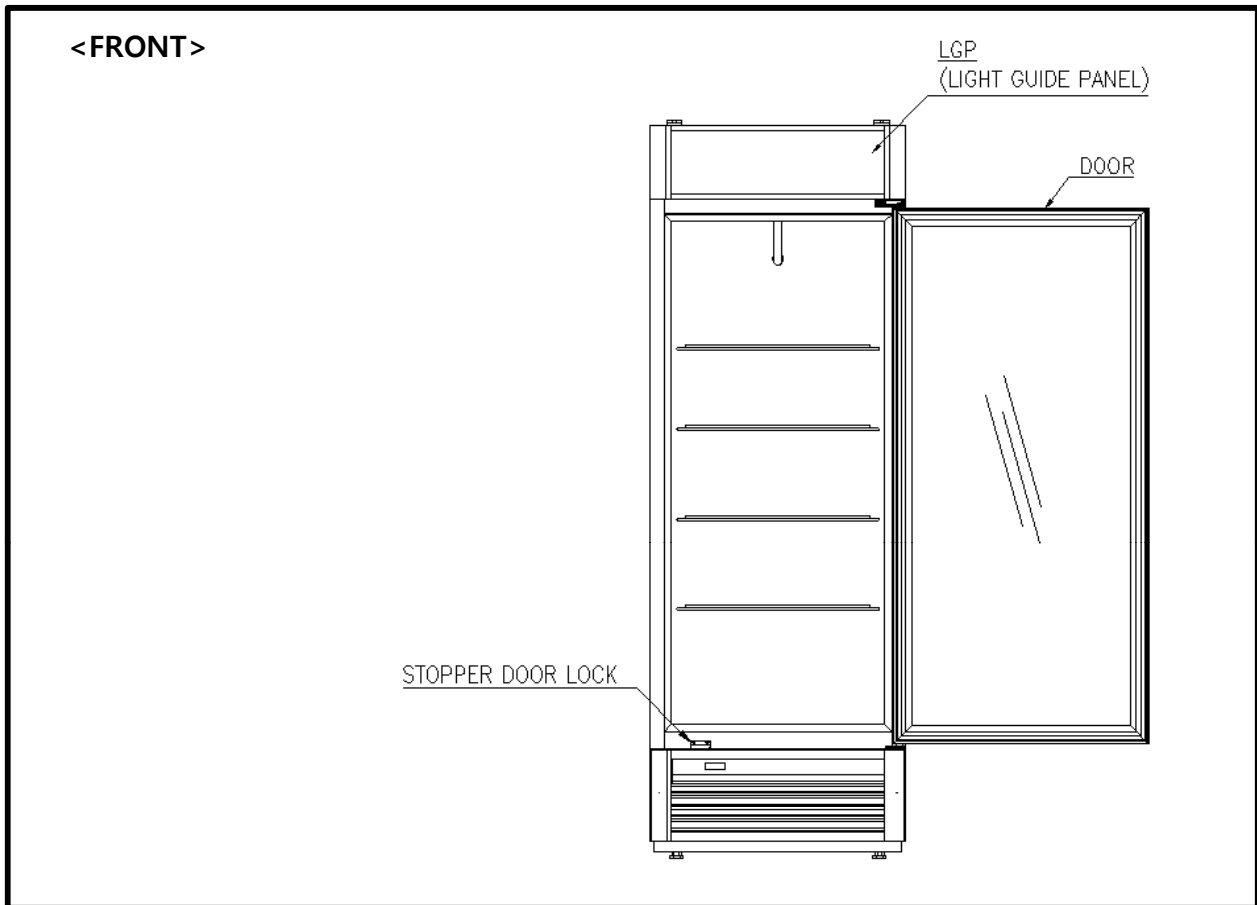

FEATURE CHART

1-4. TGM-35SD*, TGM-47SD*, TGF-35SD*, TGF-47SD*

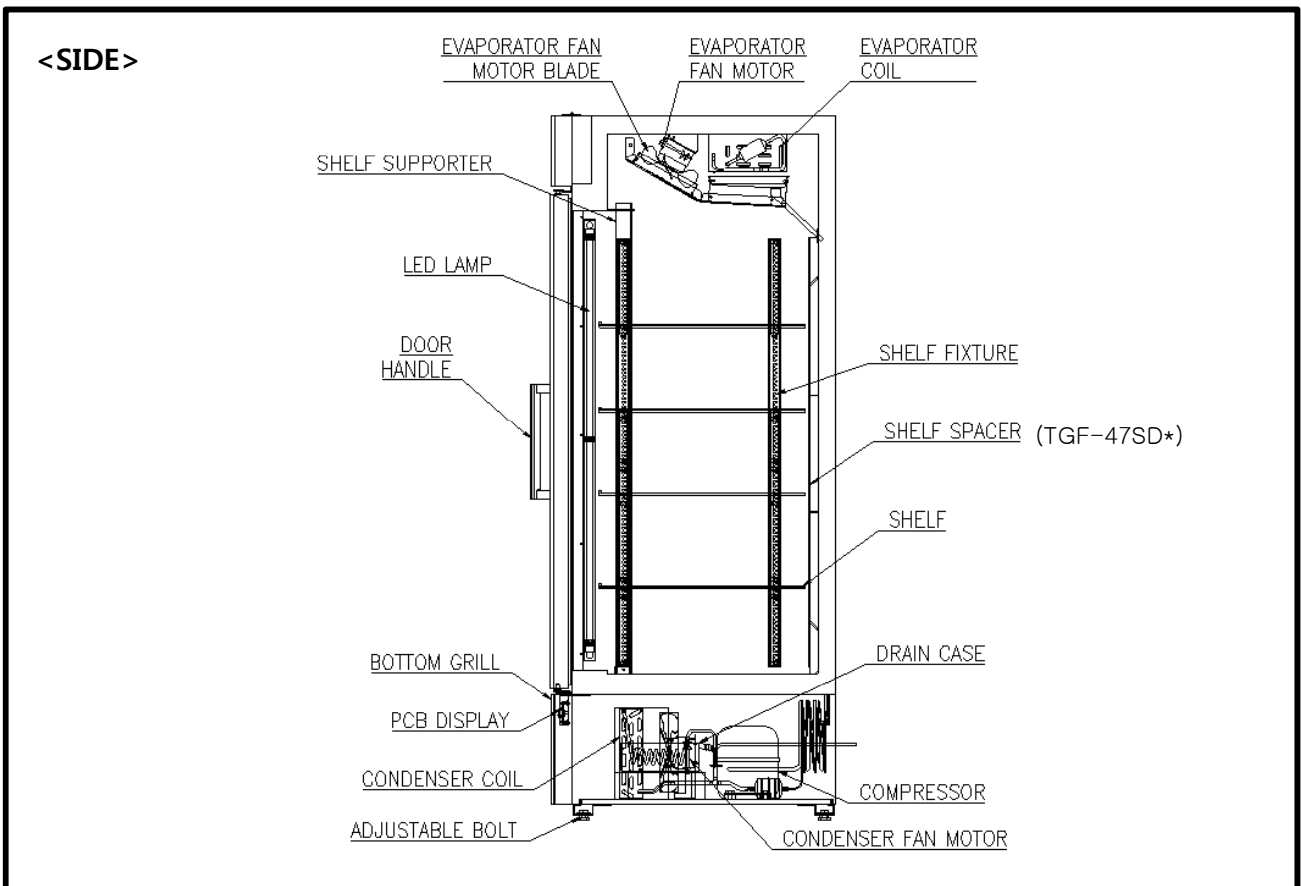
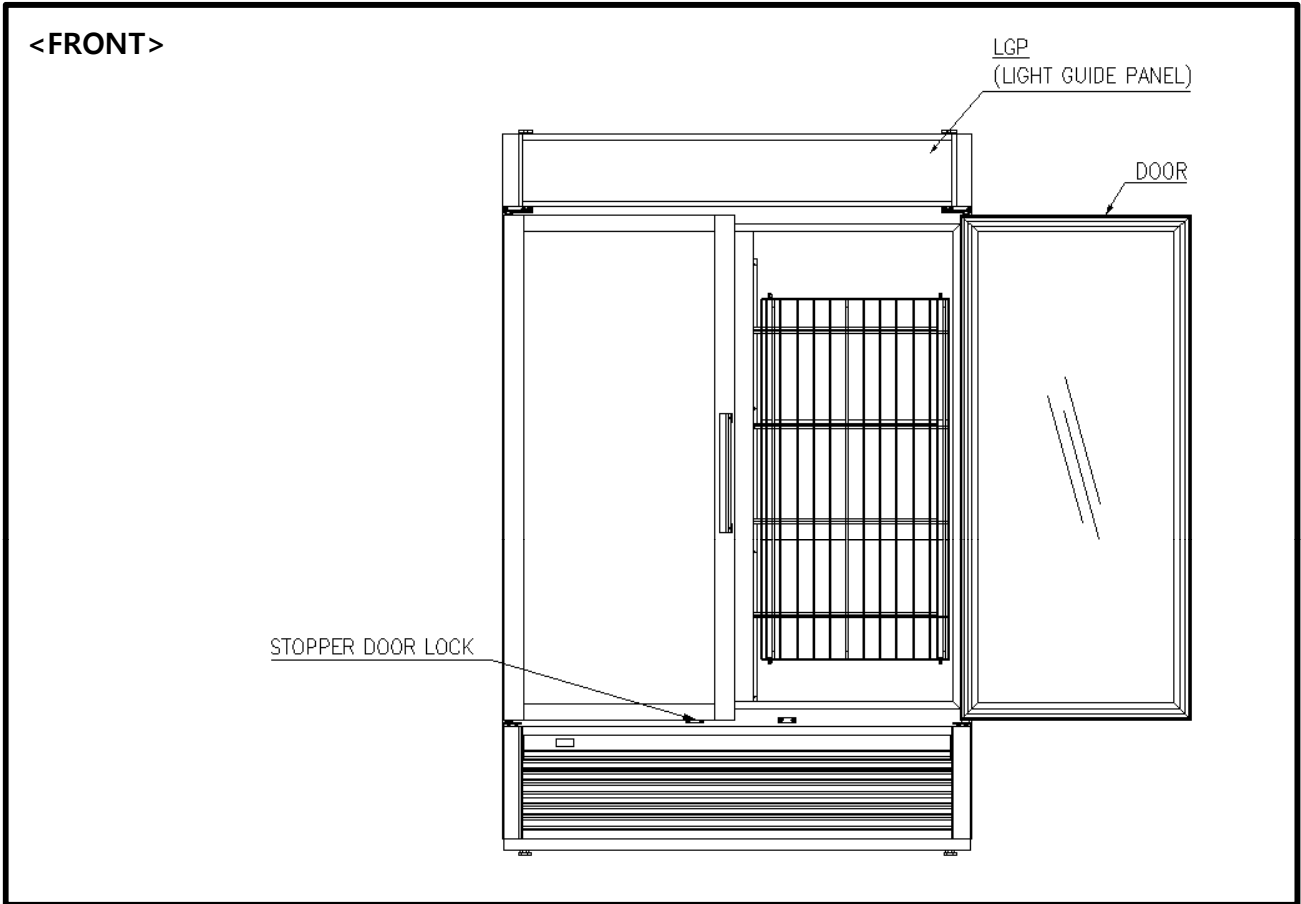

FEATURE CHART

1-5. TGM-72SD*, TGF-72SD*

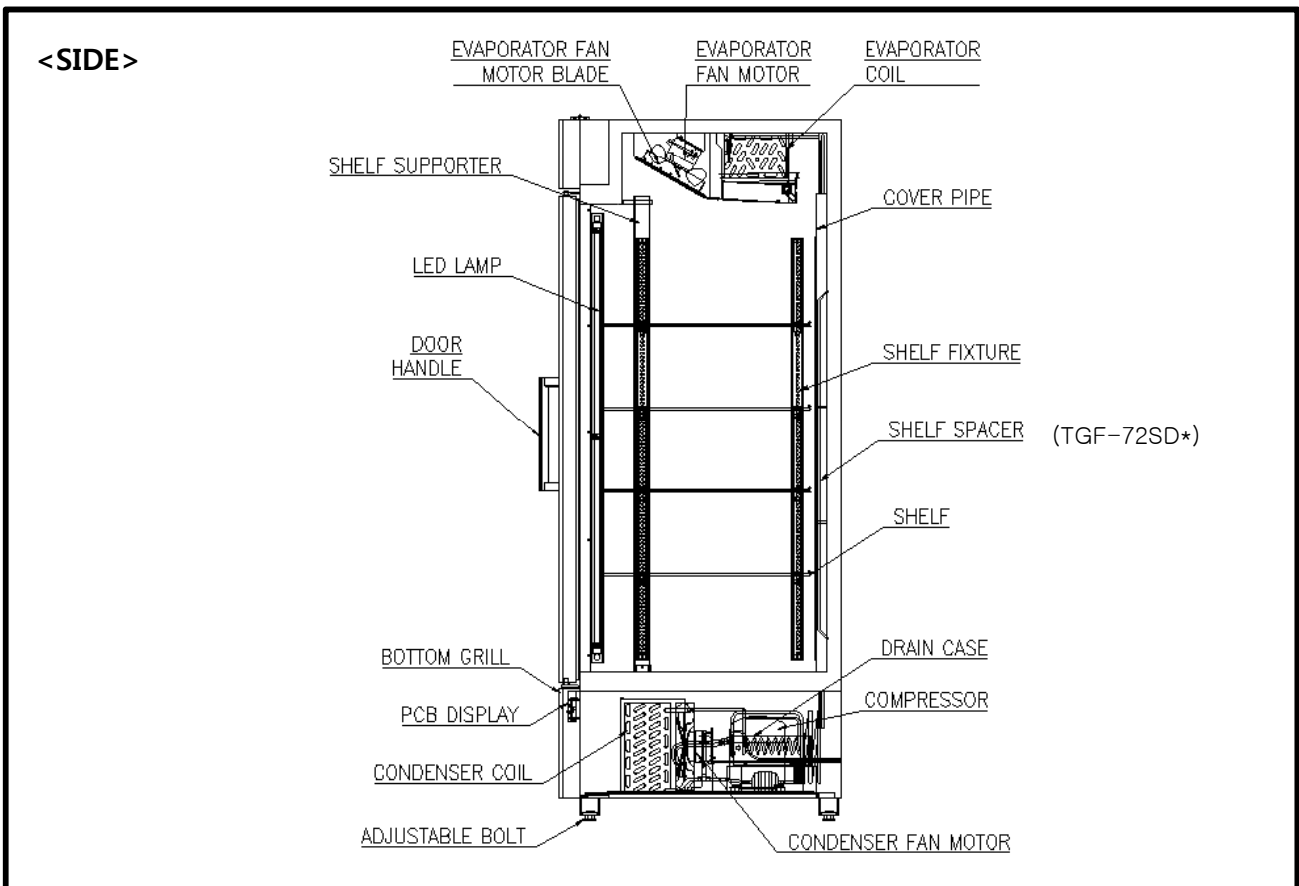
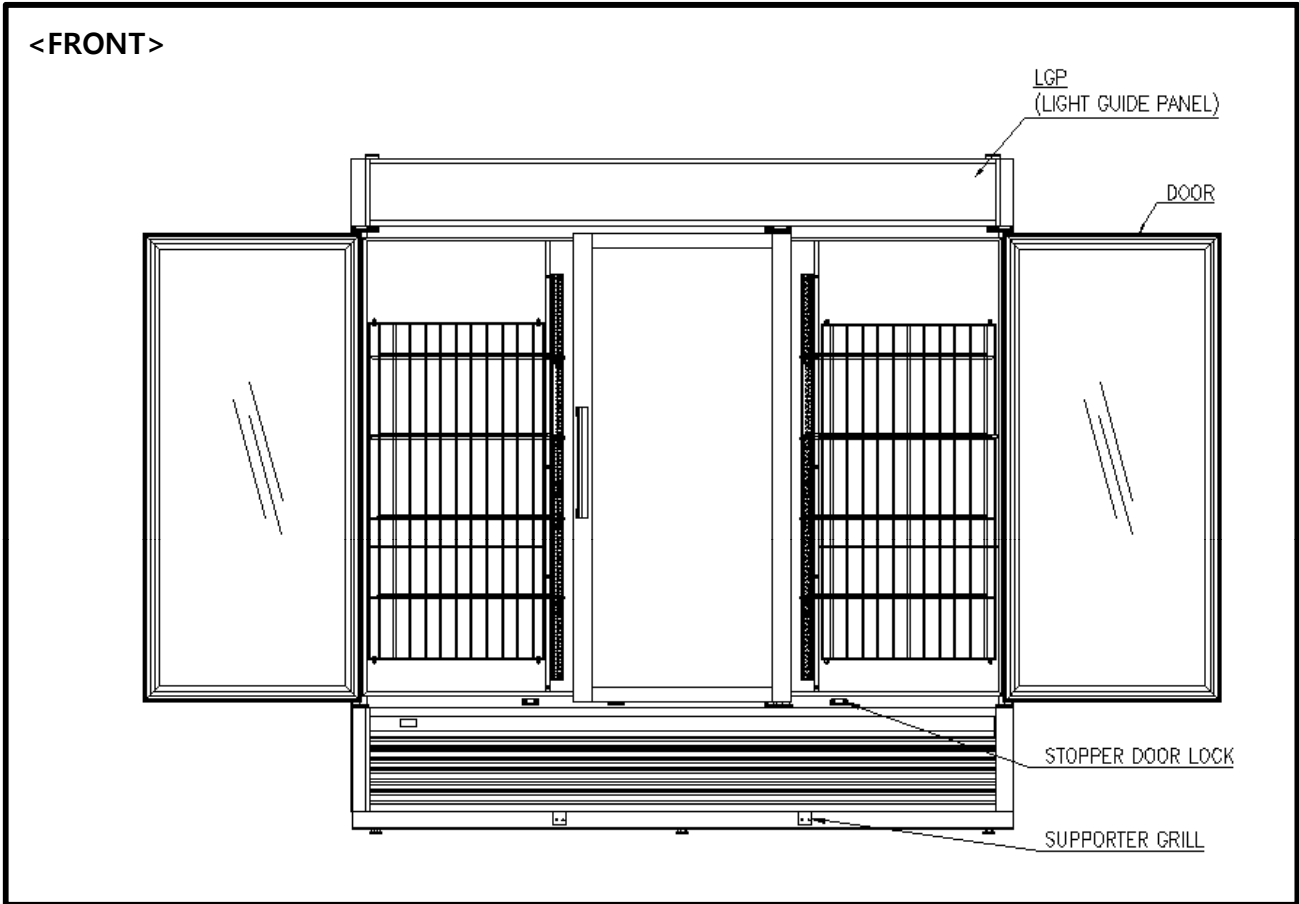

2. PART DETAILS

2-1. DOOR PARTS

2-1-1. TGM-5SD*, TGM-7SD*, TGM-10SD*, TGM-15SD*,
TGM-20SD*, TGM-23SD*, TGM-35SD*, TGM-47SD*, TGM-72SD

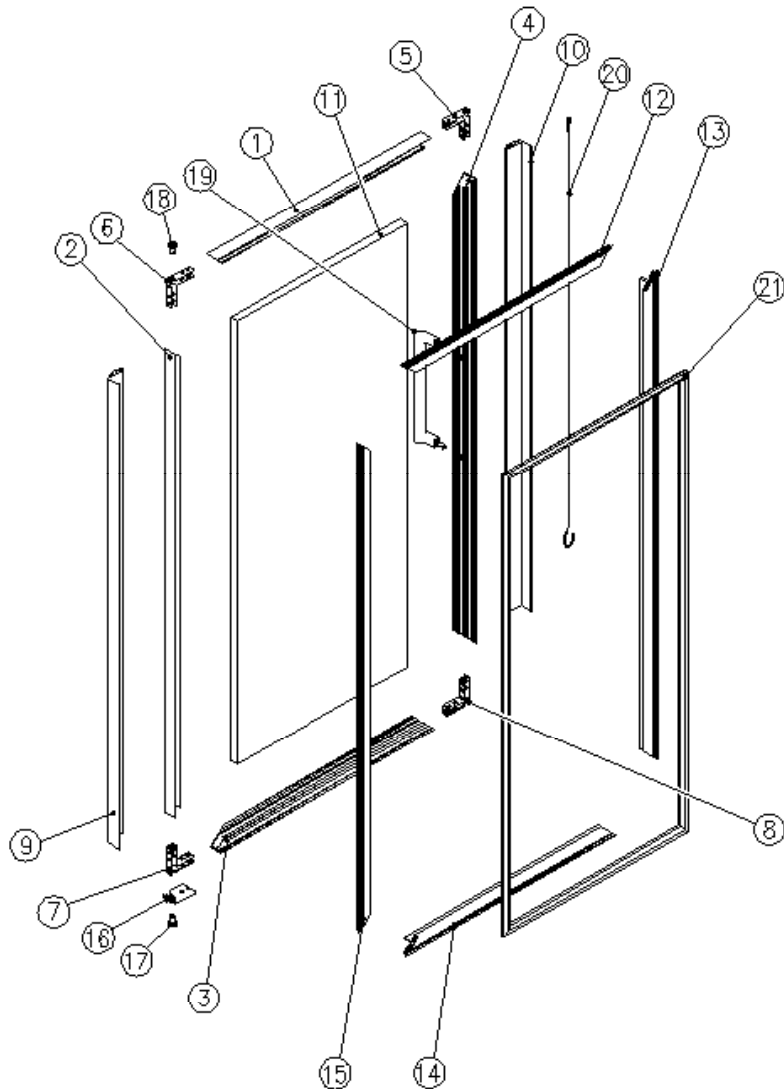

- | | |
|---|---|
| 01 DOOR FRAME *TOP | 13 AUXILIARY DOOR FRAME * LEFT |
| 02 DOOR FRAME *RIGHT | 14 AUXILIARY DOOR FRAME * BOTTOM |
| 03 DOOR FRAME *BOTTOM | 15 AUXILIARY DOOR FRAME * RIGHT |
| 04 DOOR FRAME *LEFT | 16 DOOR STOPPER (A) - RIGHT |
| 05 DOOR FRAME FIXTURE- A | 17 DOOR BUSHING *BOTTOM |
| 06 DOOR FRAME FIXTURE- B | 18 DOOR BUSHING *TOP |
| 07 DOOR FRAME FIXTURE- B | 19 DOOR HANDLE |
| 08 DOOR FRAME FIXTURE- A | 20 BAR SPRING |
| 09 DOOR FRAME DECORATION * RIGHT | 21 DOOR GASKET |
| 10 DOOR FRAME DECORATION * LEFT | |
| 11 DOOR GLASS | |
| 12 AUXILIARY DOOR FRAME * TOP | |

2. PART DETAILS

2-1-2. TGF-5SD, TGF-10SD, TGF-15SD*, TGF-23SD* TGF-35SD*, TGF-47SD*, TGF-72SD

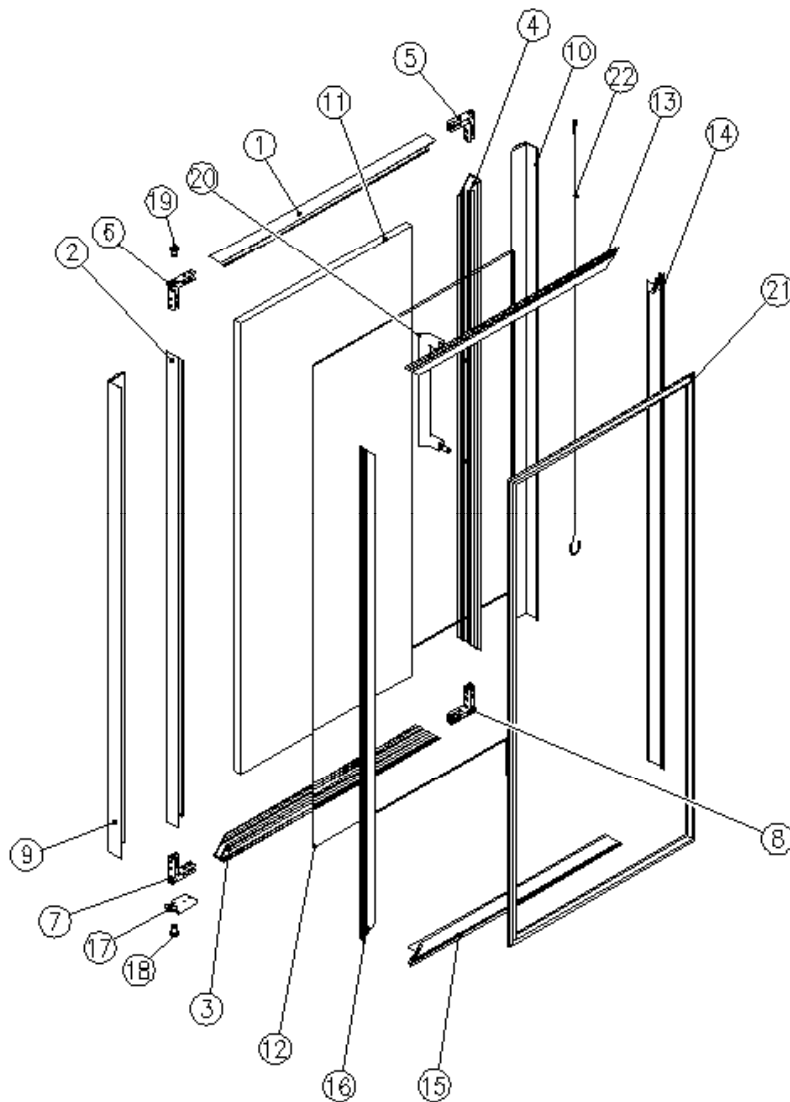

- | | |
|---|---|
| 01 DOOR FRAME *TOP | 13 AUXILIARY DOOR FRAME * TOP |
| 02 DOOR FRAME *RIGHT | 14 AUXILIARY DOOR FRAME * LEFT |
| 03 DOOR FRAME *BOTTOM | 15 AUXILIARY DOOR FRAME * BOTTOM |
| 04 DOOR FRAME *LEFT | 16 AUXILIARY DOOR FRAME * RIGHT |
| 05 DOOR FRAME FIXTURE- A | 17 DOOR STOPPER (A) - RIGHT |
| 06 DOOR FRAME FIXTURE- B | 18 DOOR BUSHING *BOTTOM |
| 07 DOOR FRAME FIXTURE- B | 19 DOOR BUSHING *TOP |
| 08 DOOR FRAME FIXTURE- A | 20 DOOR HANDLE |
| 09 DOOR FRAME DECORATION * RIGHT | 21 BAR SPRING |
| 10 DOOR FRAME DECORATION * LEFT | 22 DOOR GASKET |
| 11 DOOR GLASS | |
| 12 DOOR FRAME HEATER | |

PART DETAILS

2-2. REFRIGERATION CYCLE

■ 2-2-1. TGM-5SD*, TGM-7SD*

① DUCT

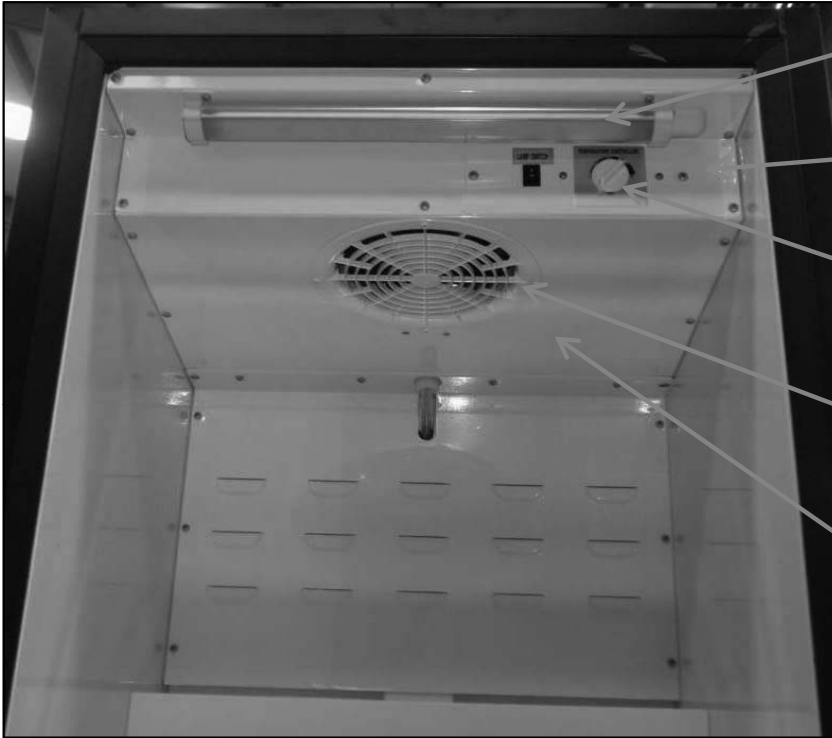

- LED
- EVAPORATOR FRONT COVER
- TEMPERATURE SENSOR
- EVAPORATOR FAN GRILLE GUARD
- EVAPORATOR BOTTOM COVER

② EVAPORATOR, FAN MOTOR, SENSORS

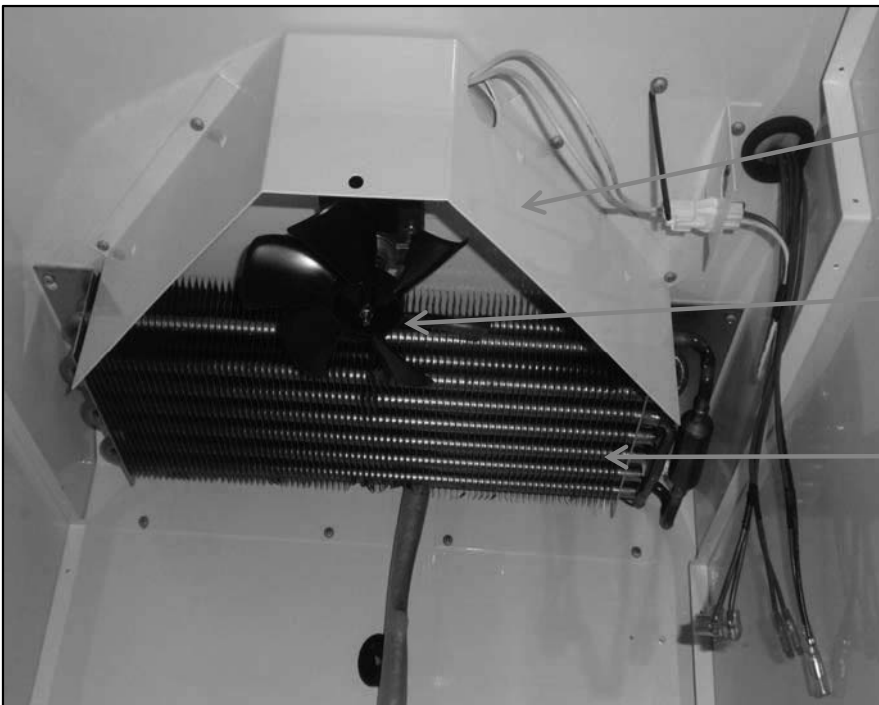

- EVAPORATOR FAN MOTOR GUARD
- EVAPORATOR FAN MOTOR & BLADE
- EVAPORATOR COIL

PART DETAILS

③ COMPRESSOR & FAN MOTOR

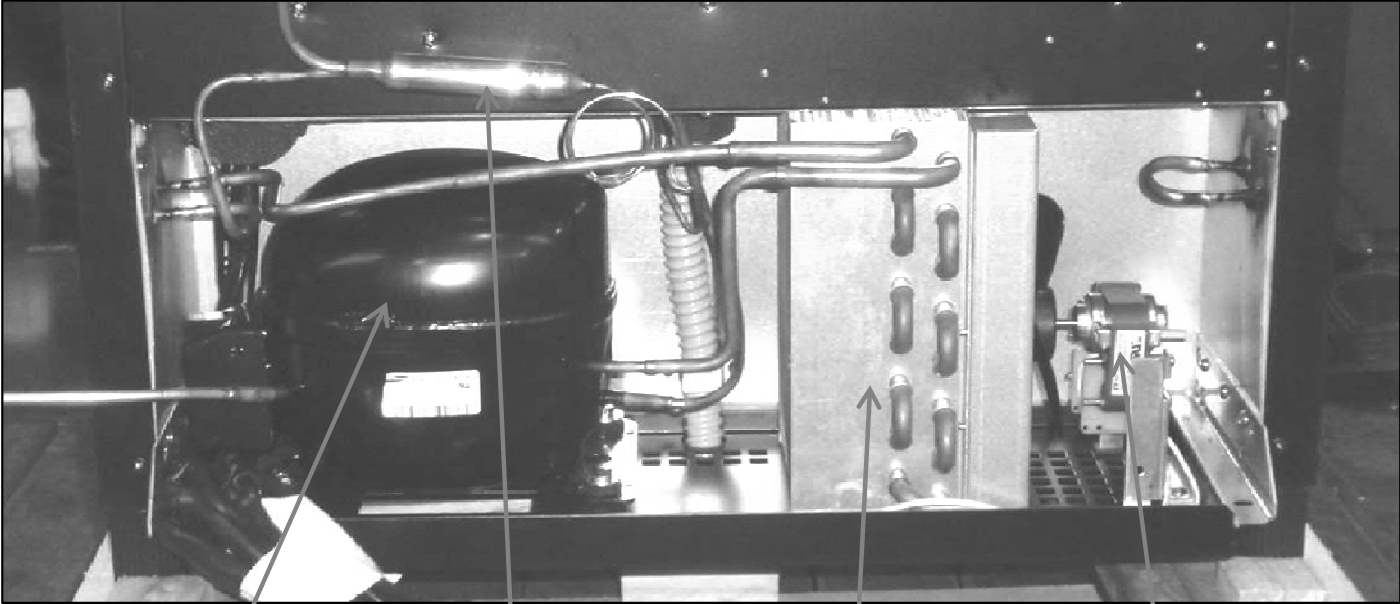

COMPRESSOR

DRYER

CONDENSER

CONDENSER
FAN MOTOR

PART DETAILS

■ 2-2-2. TGF-5SD*

① DUCT

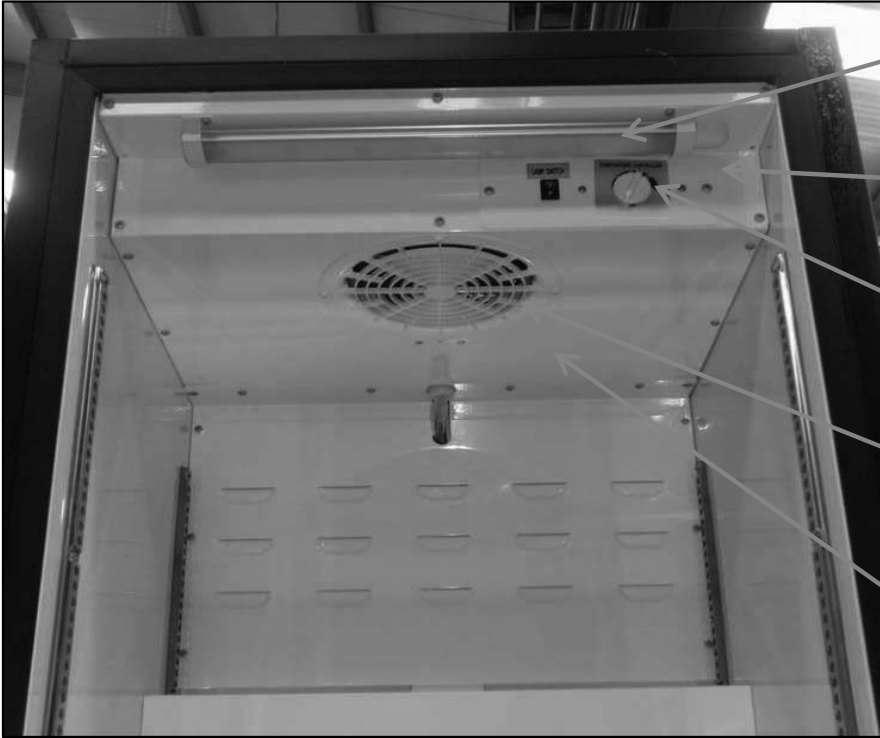

- LED
- EVAPORATOR FRONT COVER
- TEMPERATURE SENSOR
- EVAPORATOR FAN GRILLE GUARD
- EVAPORATOR BOTTOM COVER

② EVAPORATOR, FAN MOTOR, SENSORS

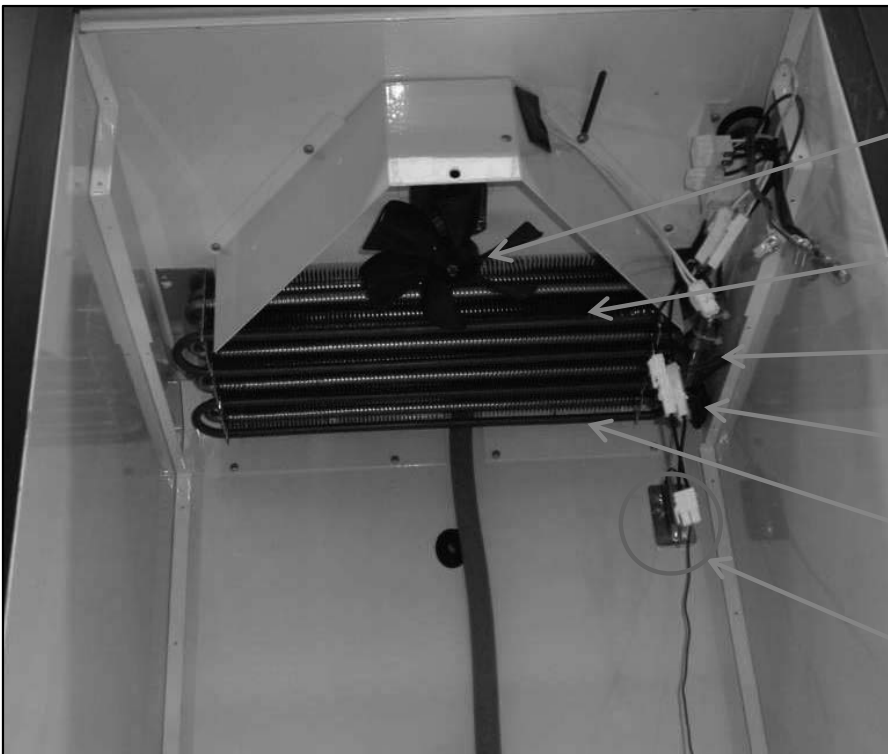

- EVAPORATOR FAN MOTOR & BLADE
- EVAPORATOR COIL
- DEFROST SENSOR
- THERMAL FUSE
- DEFROST HEATER
- TEMPERATURE SENSOR

PART DETAILS

③ COMPRESSOR & FAN MOTOR

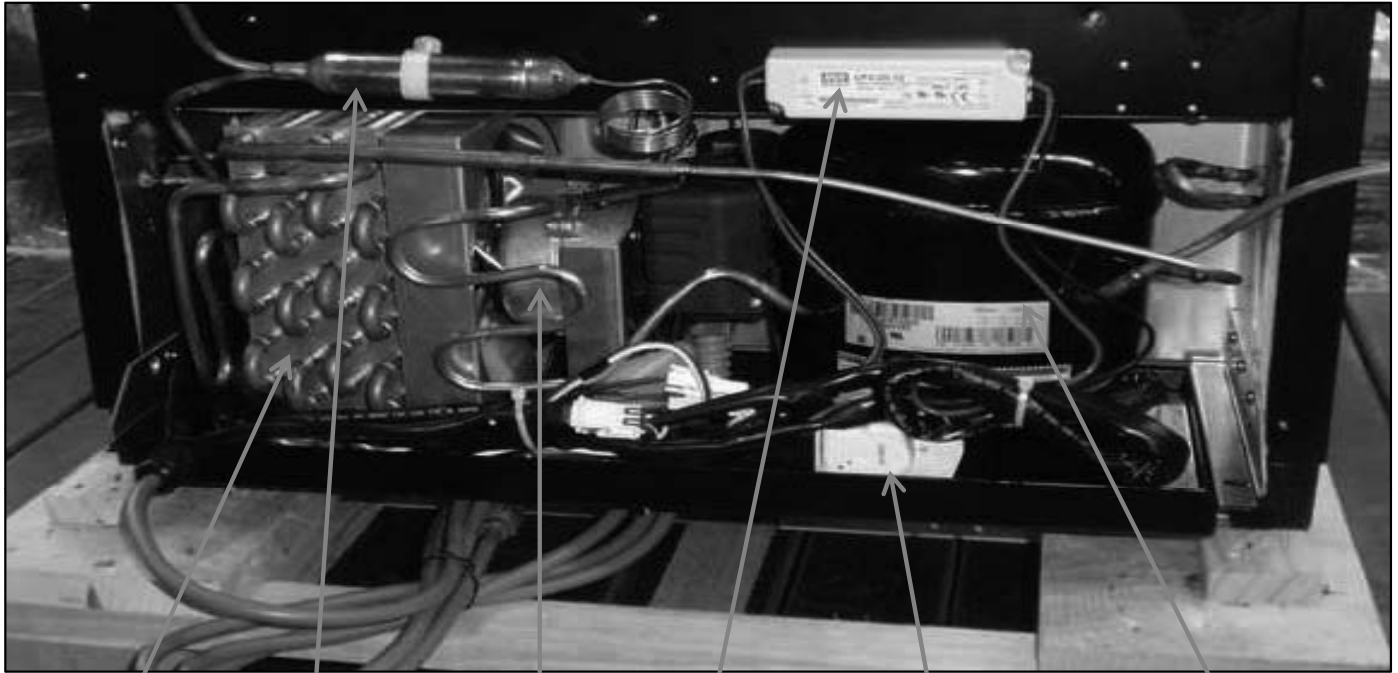

CONDENSER

DRYER

CONDENSER
FAN MOTOR

SMPS

DEFROST
TIMER

COMPRESSOR

PART DETAILS

■ 2-2-3. TGM-10SD*, TGM-12SD*

① DUCT

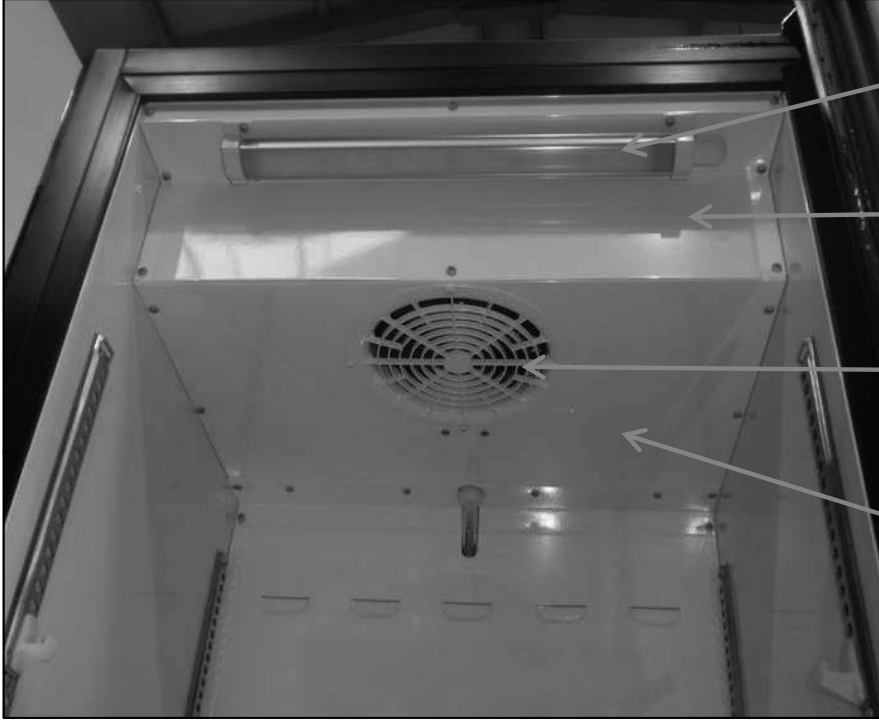

LED

EVAPORATOR
FRONT COVER

EVAPORATOR
FAN GRILLE GUARD

EVAPORATOR
BOTTOM COVER

② EVAPORATOR, FAN MOTOR, SENSORS

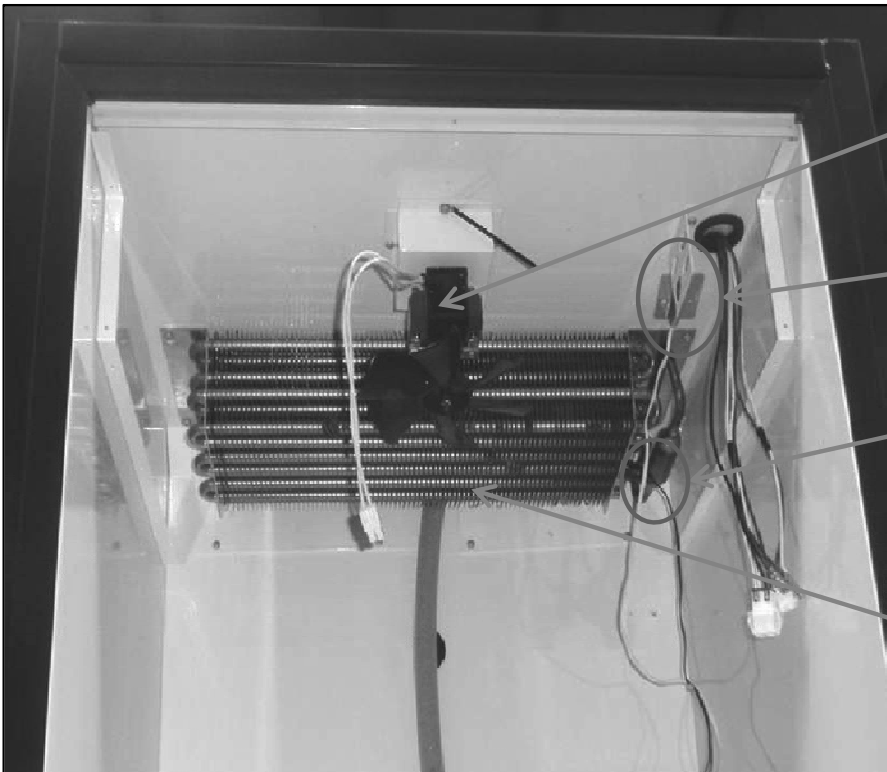

EVAPORATOR
FAN MOTOR & BLADE

R-SENSOR
(TEMPERATURE CONTROL)

DEFROST SENSOR

EVAPORATOR COIL

PART DETAILS

③ COMPRESSOR & FAN MOTOR



DRYER

COMPRESSOR

RUNNING
CAPACITOR

CONDENSER
FAN MOTOR

CONDENSER

PART DETAILS

2-2-4. TGF-10SD*

① DUCT

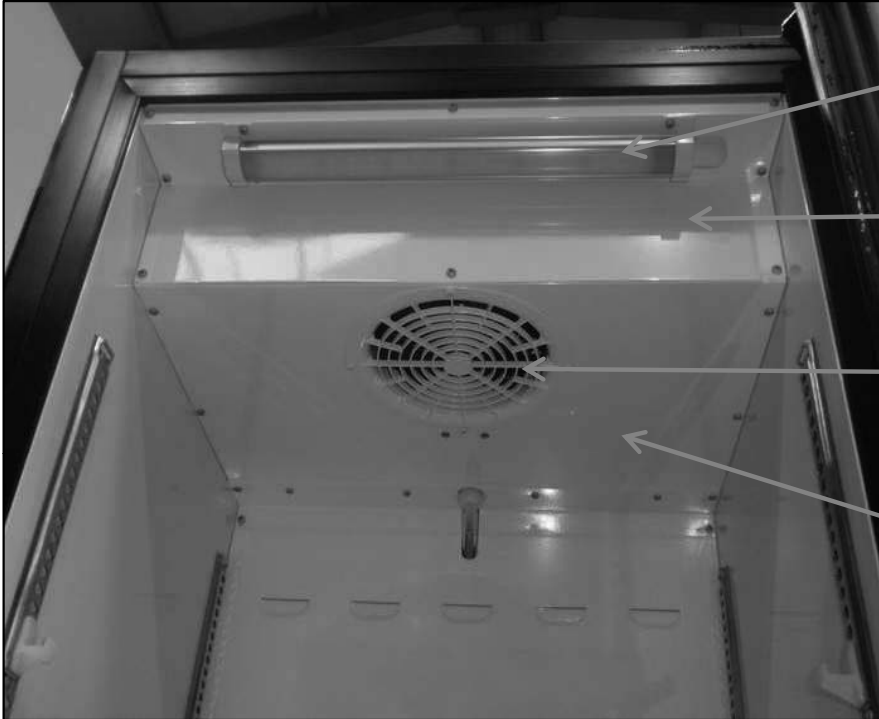

LED

EVAPORATOR
FRONT COVER

EVAPORATOR
FAN GRILLE GUARD

EVAPORATOR
BOTTOM COVER

② EVAPORATOR, FAN MOTOR, SENSORS

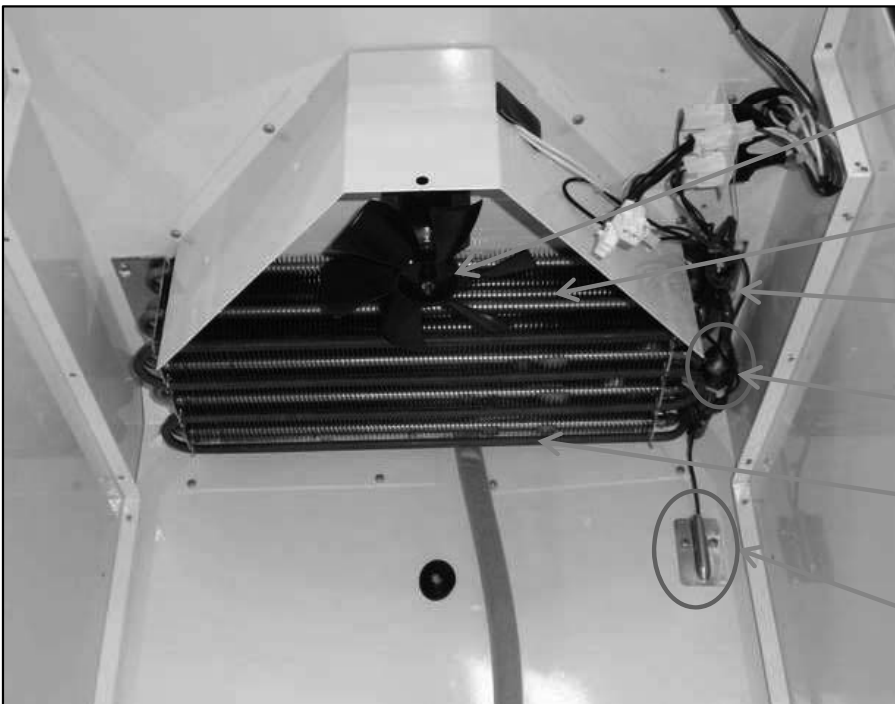

EVAPORATOR
FAN MOTOR & BLADE

EVAPORATOR COIL

THERMAL FUSE

DEFROST SENSOR

DEFROST HEATER

R-SENSOR
(TEMPERATURE CONTROL)

PART DETAILS

③ COMPRESSOR & FAN MOTOR

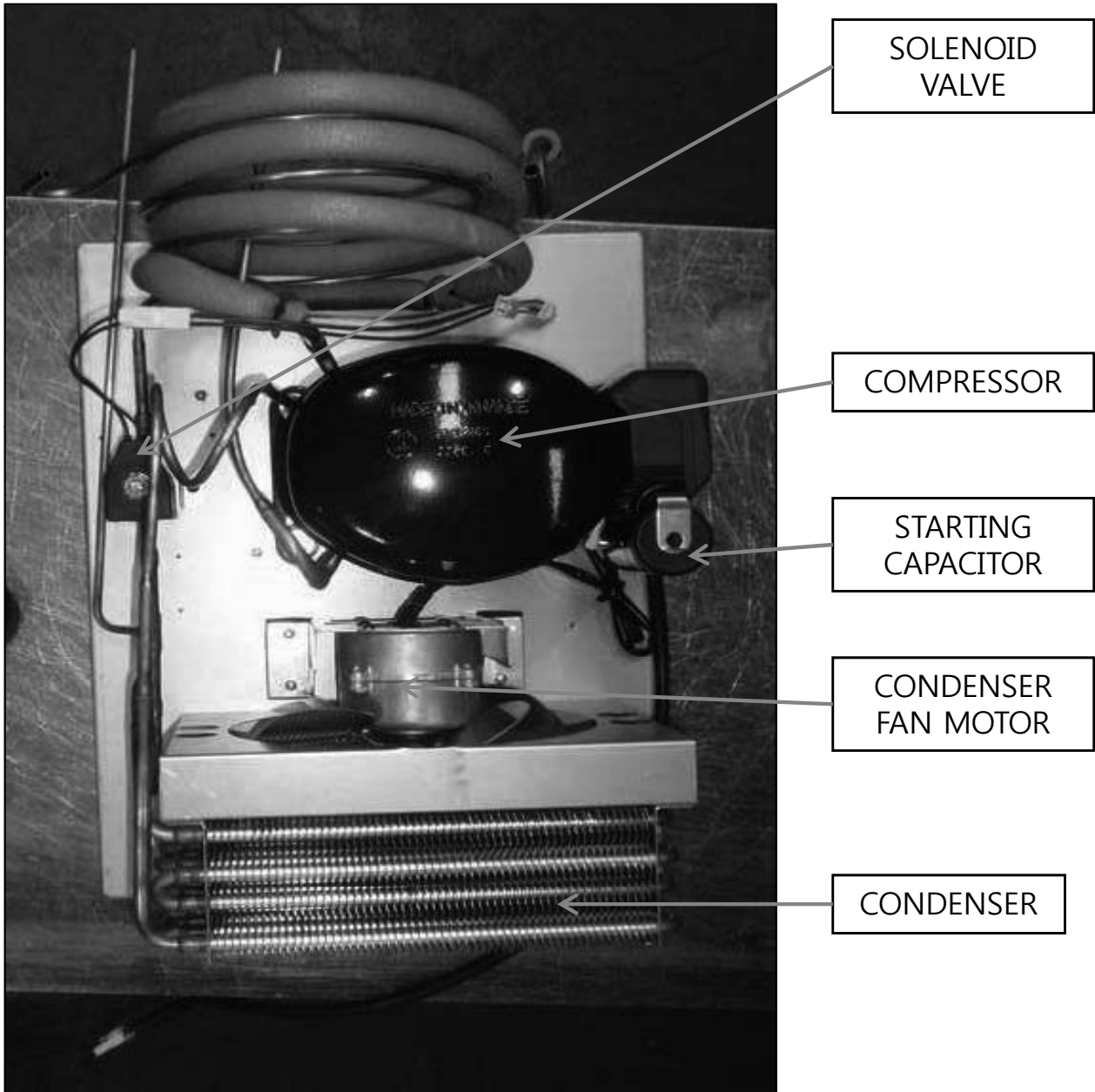

PART DETAILS

■ 2-2-5 TGM-15SD*

① DUCT

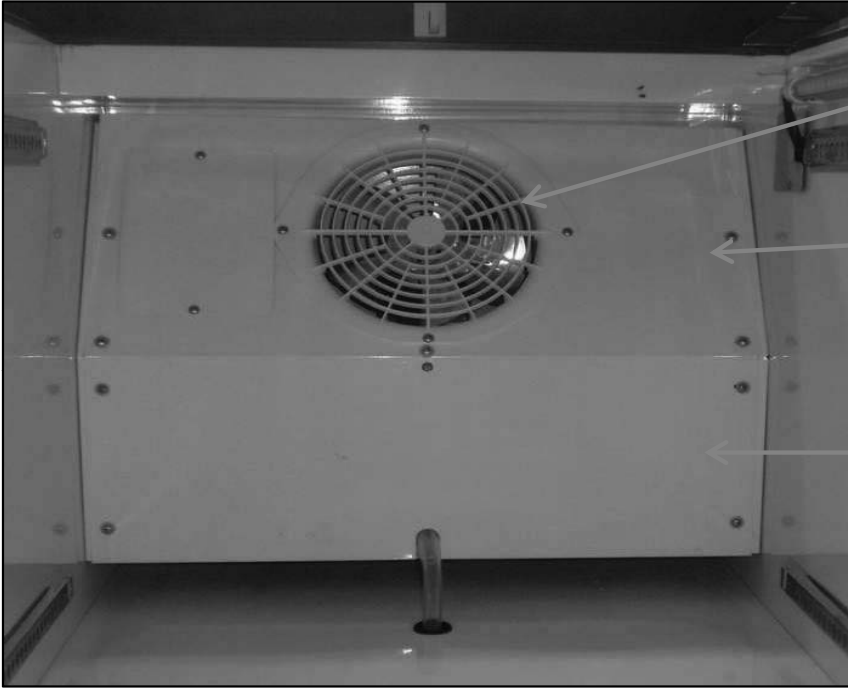

EVAPORATOR
FAN GRILLE GUARD

EVAPORATOR
FRONT COVER

EVAPORATOR
BOTTOM COVER

② EVAPORATOR, FAN MOTOR, SENSORS



EVAPORATOR
FAN MOTOR & BLADE

R-SENSOR
(TEMPERATURE CONTROL)

EVAPORATOR COIL

DEFROST SENSOR

PART DETAILS

③ COMPRESSOR & FAN MOTOR

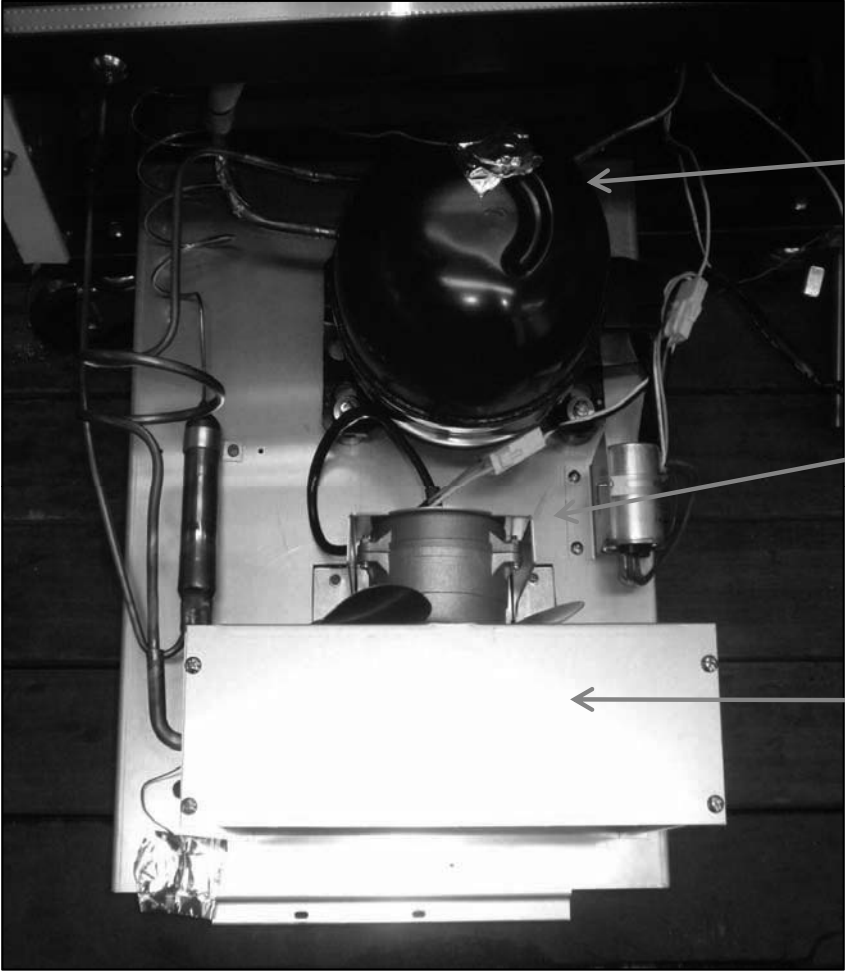

COMPRESSOR

CONDENSER
FAN MOTOR

CONDENSER

PART DETAILS

2-2-6. TGF-15SD*

① DUCT

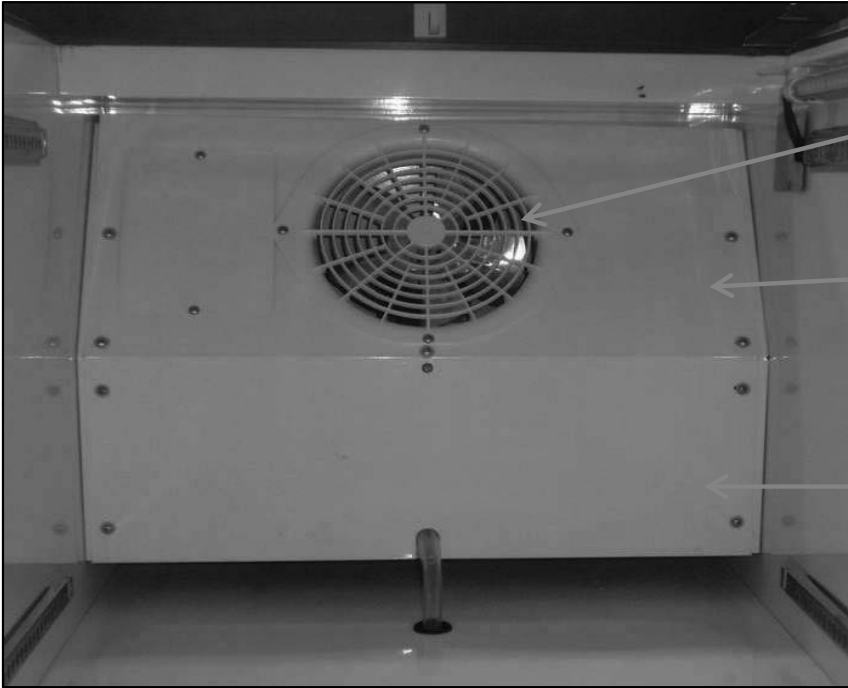

EVAPORATOR
FAN GRILLE GUARD

EVAPORATOR
FRONT COVER

EVAPORATOR
BOTTOM COVER

② EVAPORATOR, FAN MOTOR, SENSORS

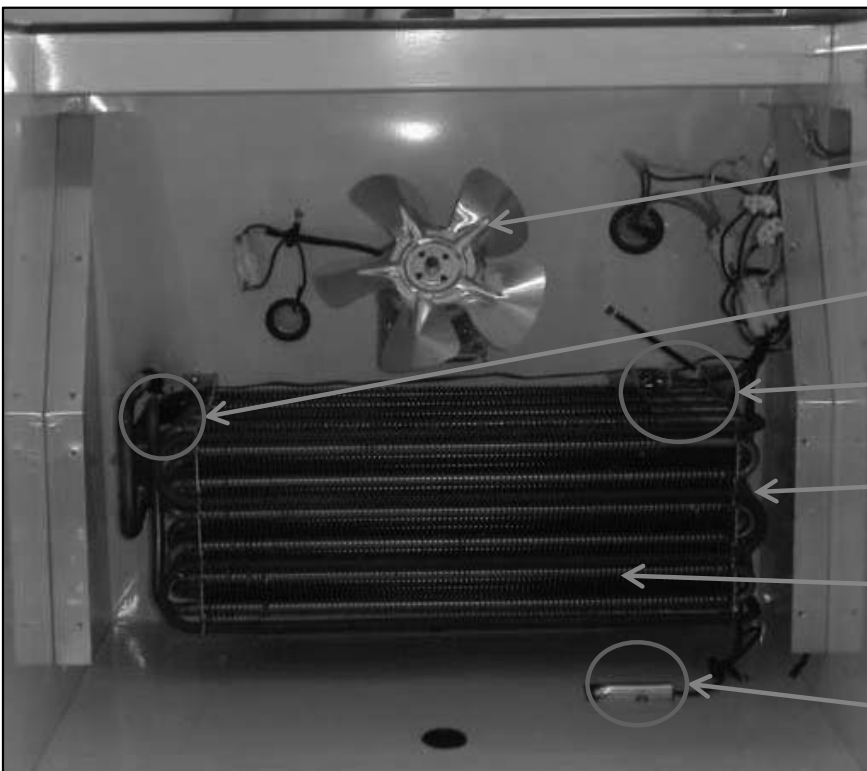

EVAPORATOR
FAN MOTOR & BLADE

DEFROST SENSOR

THERMAL FUSE

DEFROST HEATER

EVAPORATOR COIL

R-SENSOR
(TEMPERATURE CONTROL)

PART DETAILS

③ COMPRESSOR & FAN MOTOR



SOLENOID VALVE

COMPRESSOR

STARTING CAPACITOR

CONDENSER FAN MOTOR

CONDENSER

PART DETAILS

■ 2-2-7. TGM-20SD*, TGM-23SD*

① DUCT

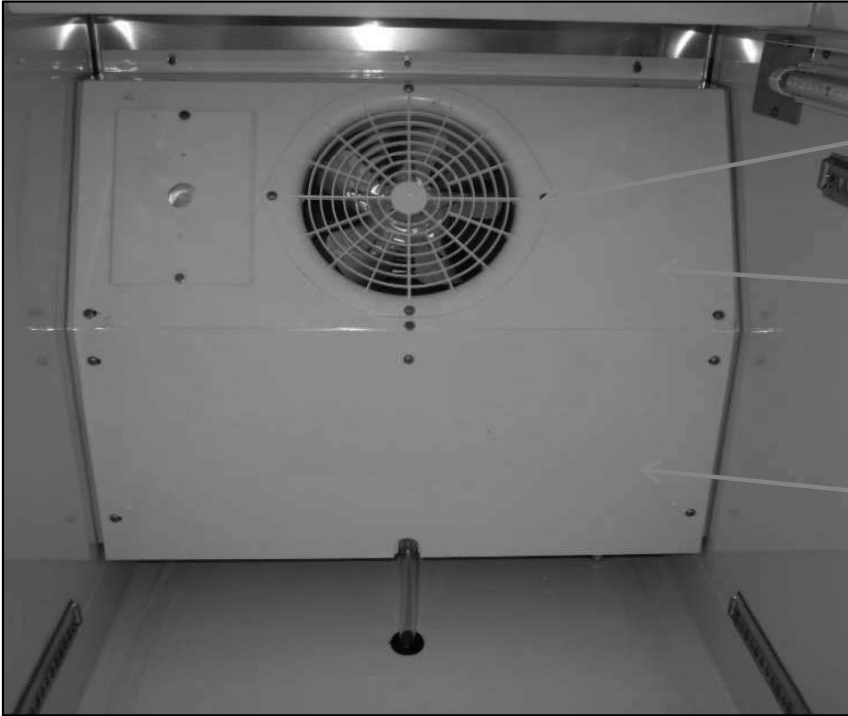

EVAPORATOR
FAN GRILLE GUARD

EVAPORATOR
FRONT COVER

EVAPORATOR
BOTTOM COVER

② EVAPORATOR, FAN MOTOR, SENSORS

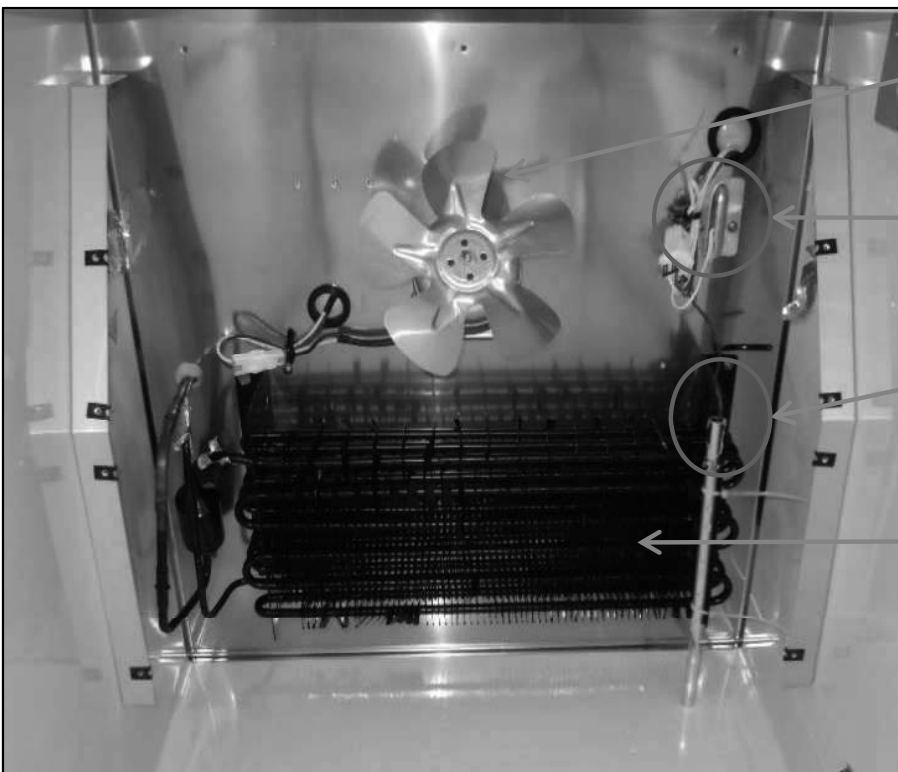

EVAPORATOR
FAN MOTOR & BLADE

R-SENSOR
(TEMPERATURE CONTROL)

DEFROST SENSOR

EVAPORATOR COIL

PART DETAILS

③ COMPRESSOR & FAN MOTOR

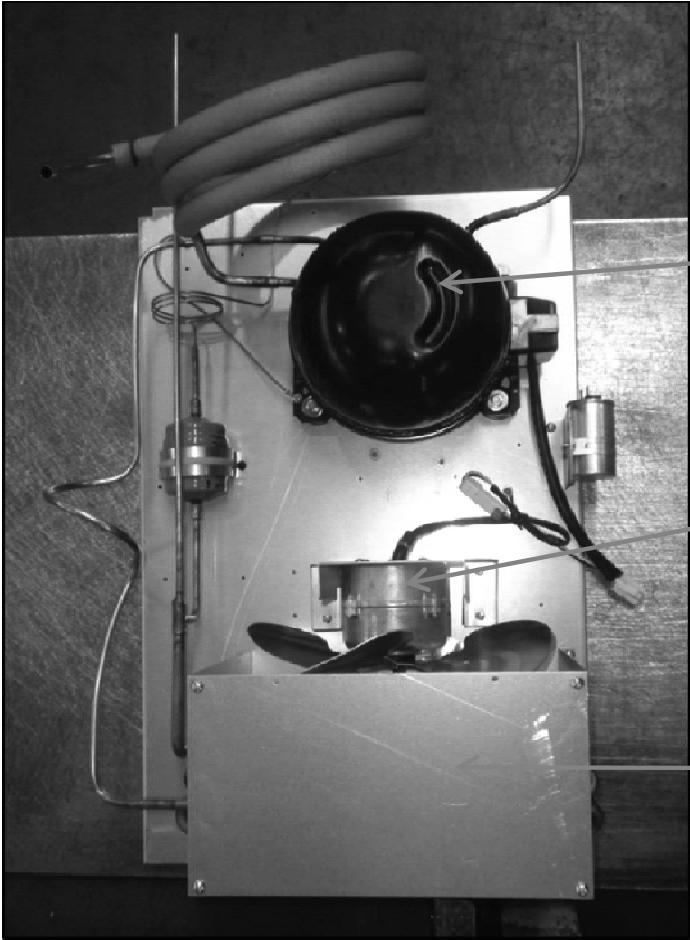

COMPRESSOR

CONDENSER
FAN MOTOR

CONDENSER

PART DETAILS

■ 2-2-8. TGF-23SD*

① DUCT

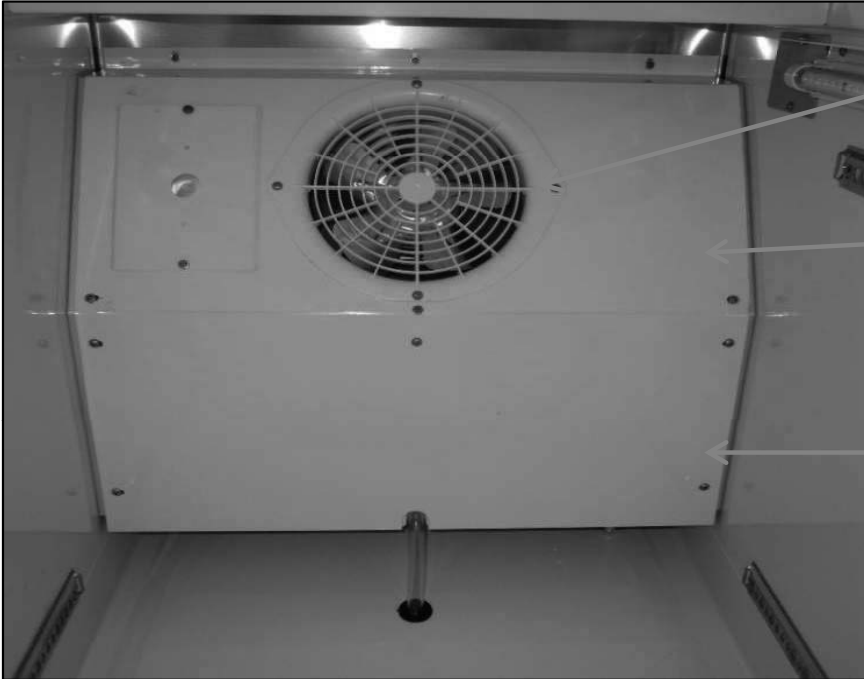

EVAPORATOR
FAN GRILLE GUARD

EVAPORATOR
FRONT COVER

EVAPORATOR
BOTTOM COVER

② EVAPORATOR, FAN MOTOR, DEFROST HEATER, SENSORS



EVAPORATOR
FAN MOTOR & BLADE

EVAPORATOR COIL

THERMAL FUSE

DEFROST HEATER

DEFROST SENSOR

F-SENSOR
(TEMPERATURE CONTROL)

PART DETAILS

③ COMPRESSOR & FAN MOTOR

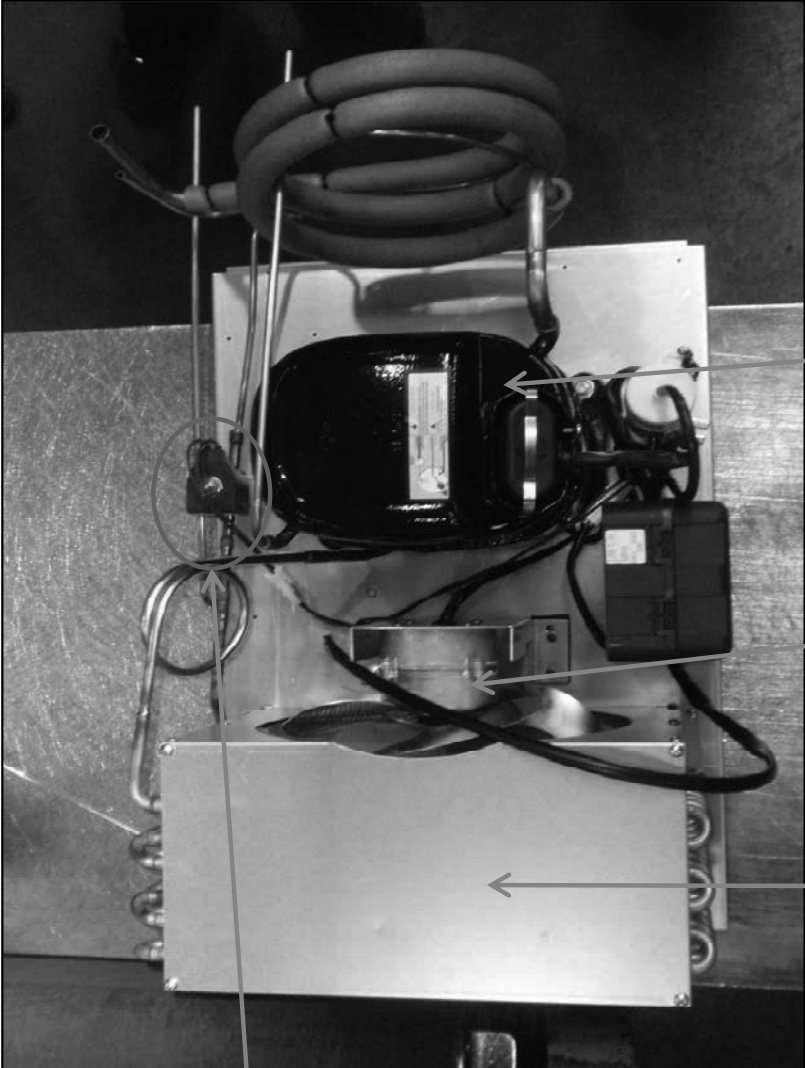

COMPRESSOR

CONDENSER
FAN MOTOR

CONDENSER

SOLENOID VALVE

PART DETAILS

■ 2-2-9. TGM-35SD*, TGM-47SD*

① DUCT(TGM-35SD*)

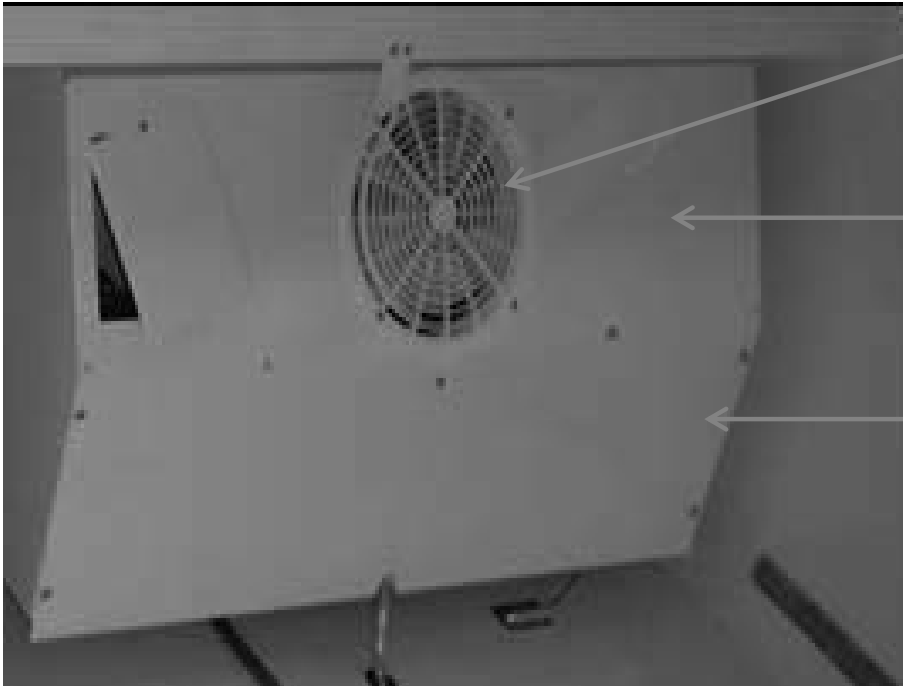

EVAPORATOR
FAN GRILLE GUARD

EVAPORATOR
FRONT COVER

EVAPORATOR
BOTTOM COVER

② EVAPORATOR, FAN MOTOR, SENSORS(TGM-35SD*)

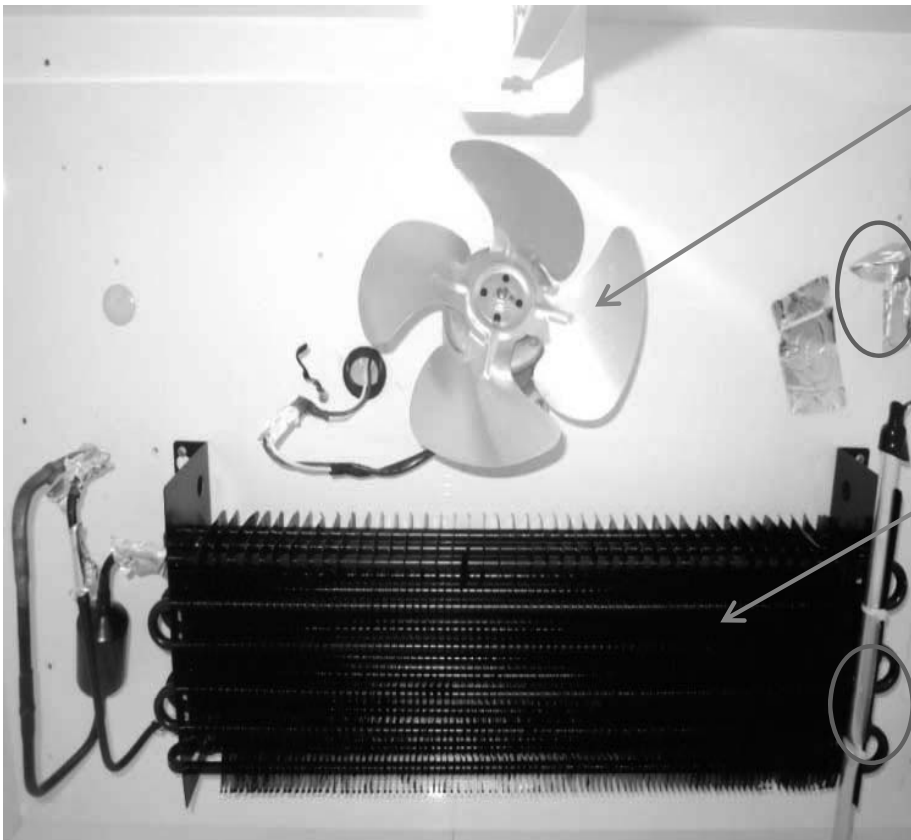

EVAPORATOR
FAN MOTOR & BLADE

R-SENSOR
(TEMPERATURE CONTROL)

EVAPORATOR COIL

DEFROST SENSOR

PART DETAILS

■ 2-2-9. TGM-35SD*, TGM-47SD*

① DUCT(TGM-47SD*)

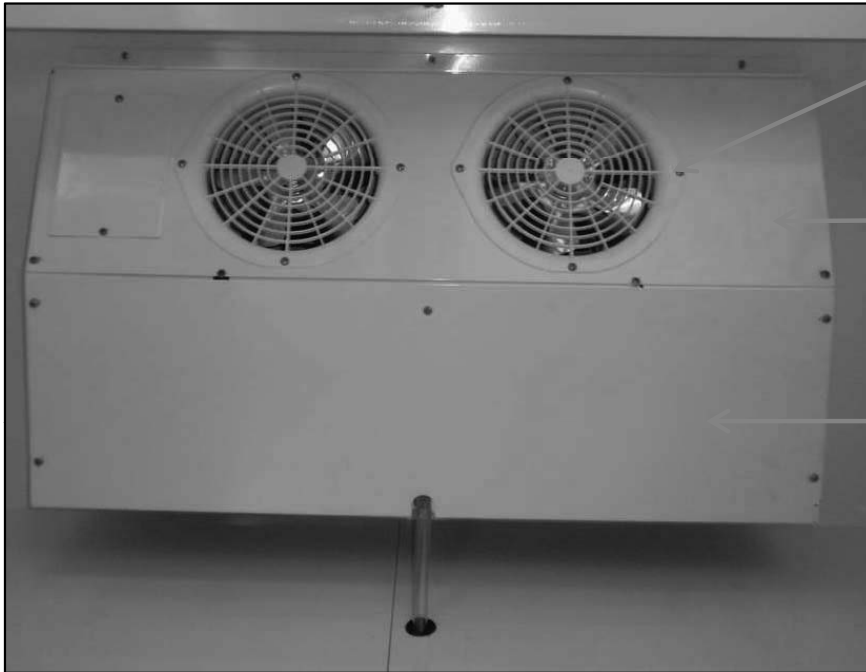

EVAPORATOR
FAN GRILLE GUARD

EVAPORATOR
FRONT COVER

EVAPORATOR
BOTTOM COVER

② EVAPORATOR, FAN MOTOR, SENSORS(TGM-47SD*)

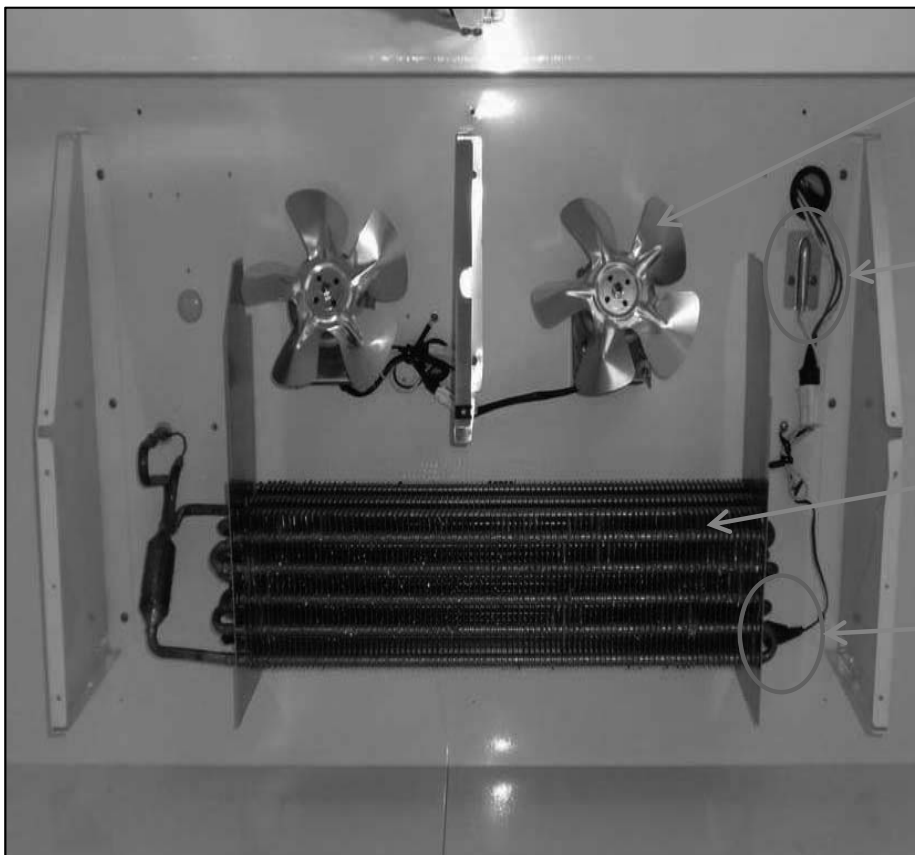

EVAPORATOR
FAN MOTOR & BLADE

R-SENSOR
(TEMPERATURE CONTROL)

EVAPORATOR COIL

DEFROST SENSOR

PART DETAILS

③ COMPRESSOR & FAN MOTOR(TGM-35SD*, TGM-47SD*)

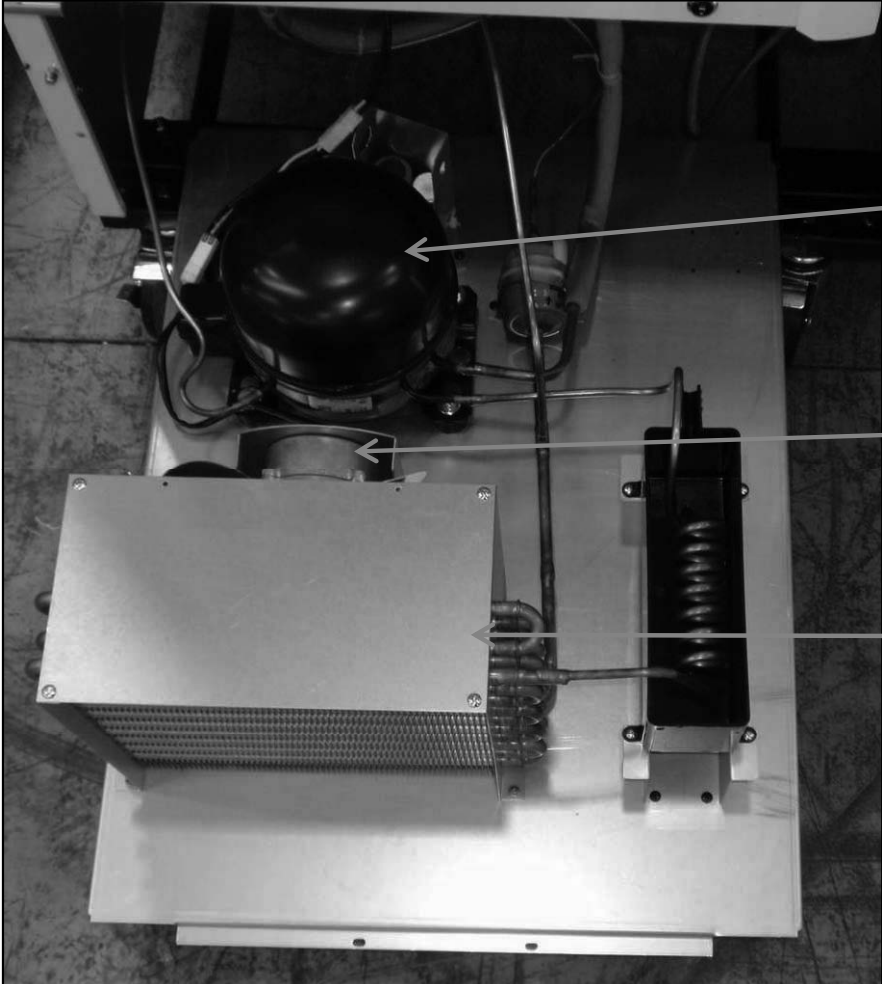

COMPRESSOR

CONDENSER
FAN MOTOR

CONDENSER

PART DETAILS

■ 2-2-10. TGF-35SD*, TGF-47SD*

① DUCT(TGF-35SD*)

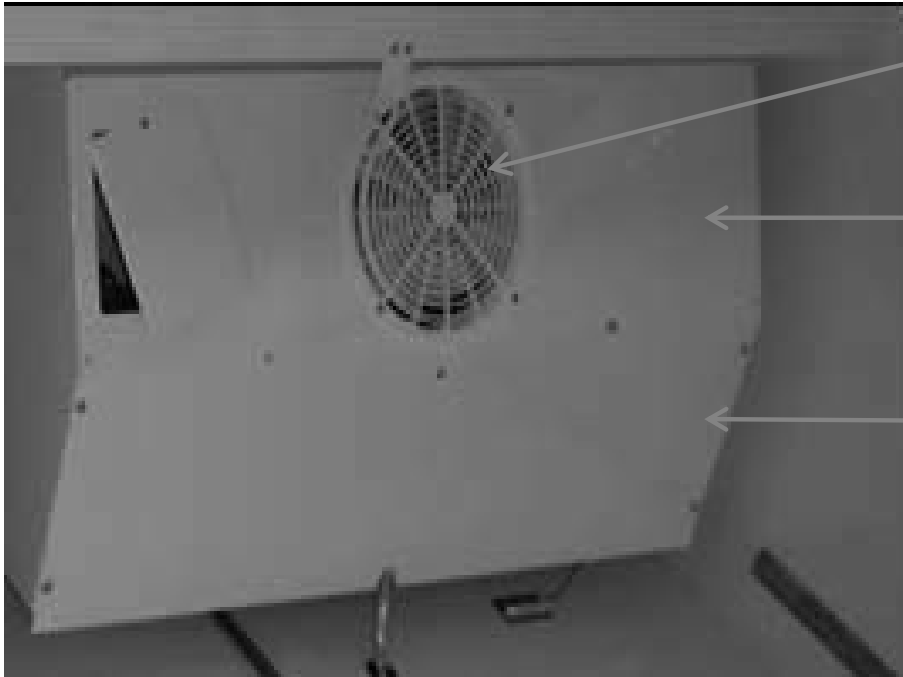

EVAPORATOR
FAN GRILLE GUARD

EVAPORATOR
FRONT COVER

EVAPORATOR
BOTTOM COVER

② EVAPORATOR, FAN MOTOR, DEFROST HEATER, SENSORS(TGF-35SD*)



EVAPORATOR
FAN MOTOR & BLADE

THERMAL FUSE

EVAPORATOR COIL

DEFROST HEATER

DEFROST SENSOR

F-SENSOR
(TEMPERATURE CONTROL)

PART DETAILS

■ 2-2-10. TGF-35SD*, TGF-47SD*

① DUCT(TGF-47SD*)

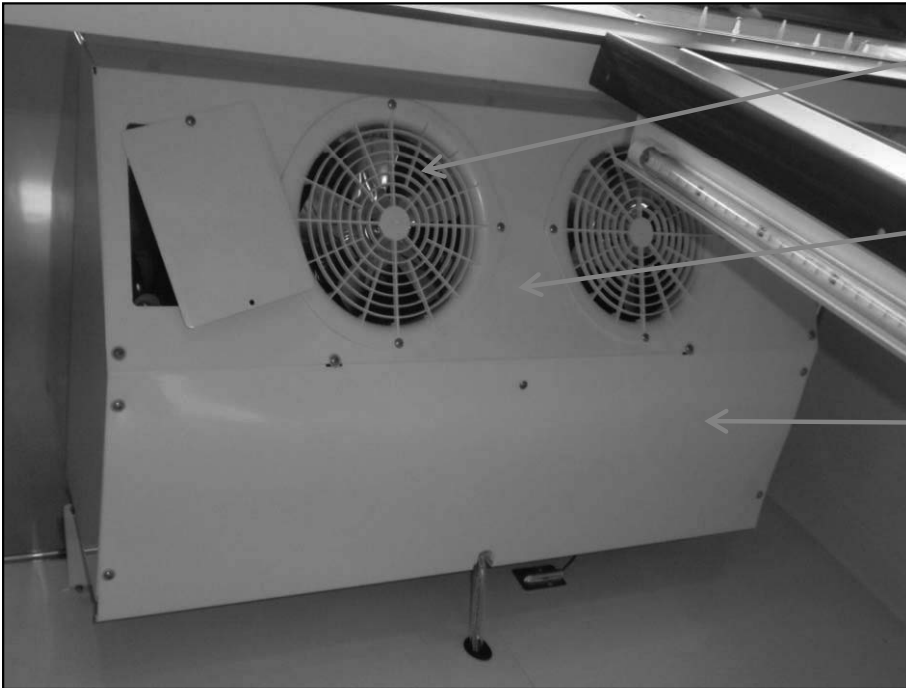

EVAPORATOR
FAN GRILLE GUARD

EVAPORATOR
FRONT COVER

EVAPORATOR
BOTTOM COVER

② EVAPORATOR, FAN MOTOR, DEFROST HEATER, SENSORS(TGF-47SD*)



EVAPORATOR
FAN MOTOR & BLADE

THERMAL FUSE

EVAPORATOR COIL

DEFROST HEATER

DEFROST SENSOR

F-SENSOR
(TEMPERATURE CONTROL)

PART DETAILS

③ COMPRESSOR & FAN MOTOR(TGF-35SD*, TGF-47SD*)



COMPRESSOR

CONDENSER
FAN MOTOR

CONDENSER

PART DETAILS

■ 2-2-11. TGM-72SD*

① DUCT

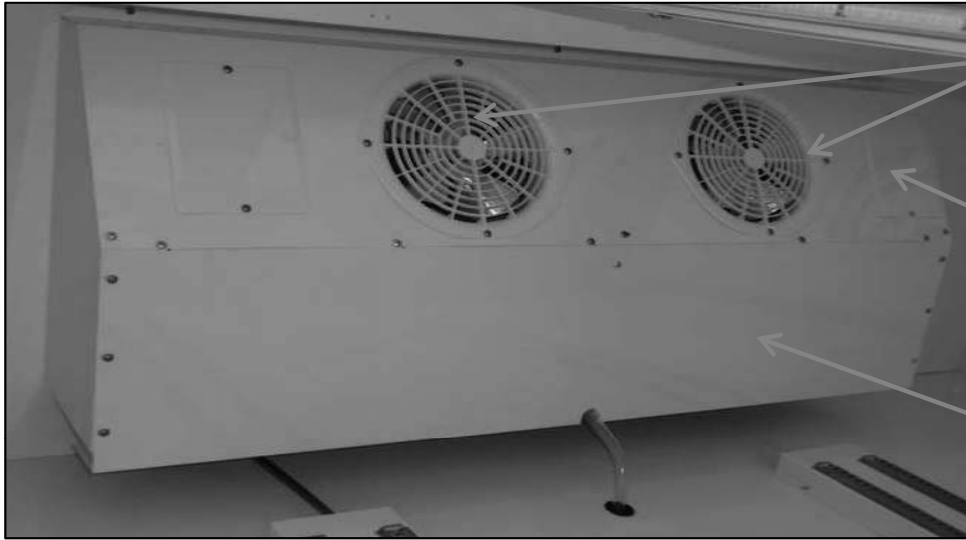

EVAPORATOR
FAN GRILLE GUARD

EVAPORATOR
FRONT COVER

EVAPORATOR
BOTTOM COVER

② EVAPORATOR, FAN MOTOR, SENSORS

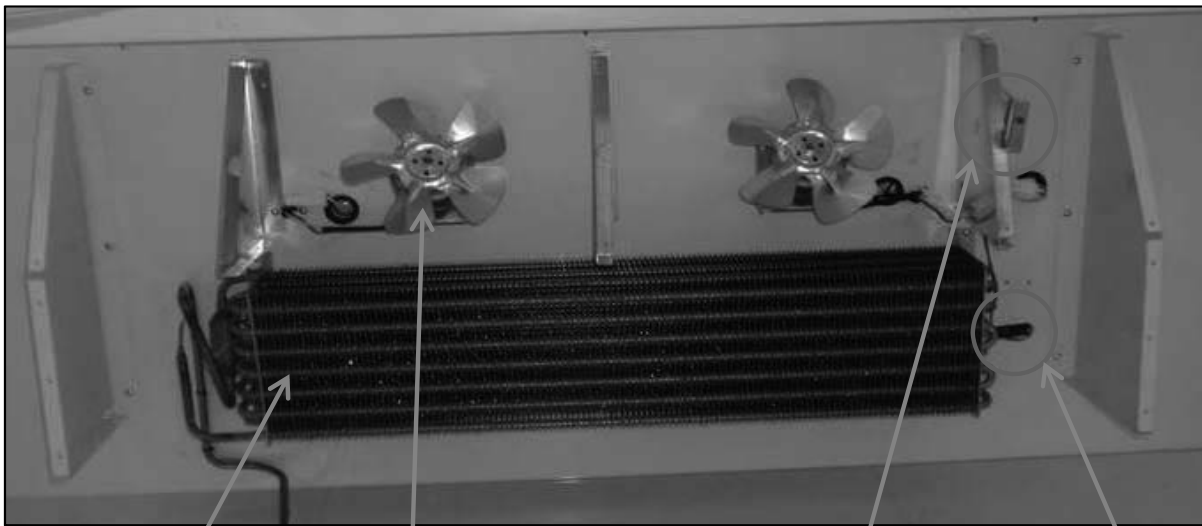

EVAPORATOR COIL

EVAPORATOR
FAN MOTOR & BLADE

R-SENSOR
(TEMPERATURE CONTROL)

DEFROST SENSOR

PART DETAILS

③ COMPRESSOR & FAN MOTOR

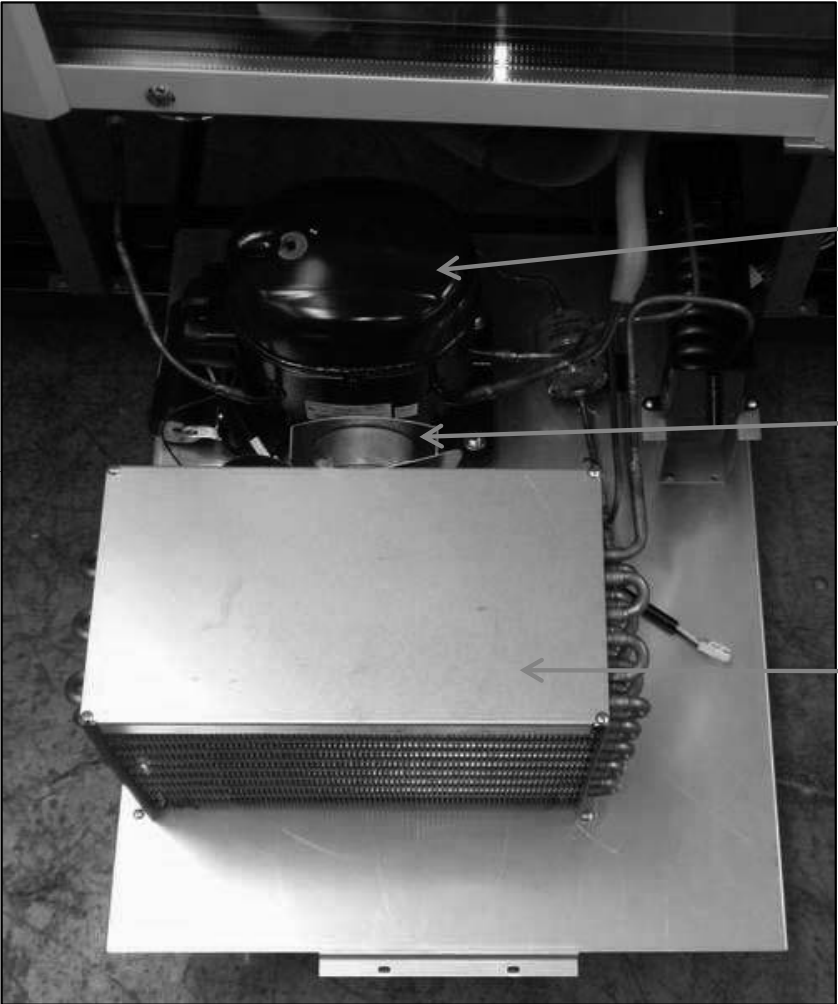

COMPRESSOR

CONDENSER
FAN MOTOR

CONDENSER

PART DETAILS

2-2-12. TGF-72SD*

① DUCT

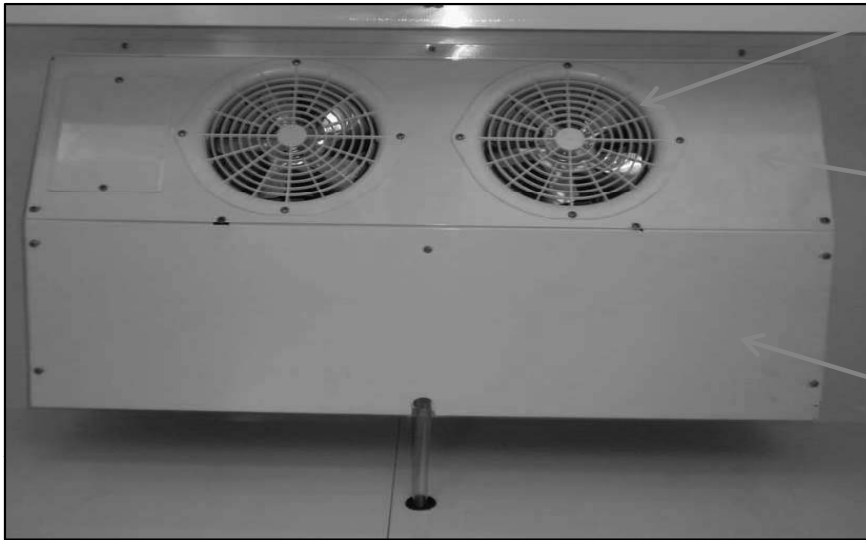

EVAPORATOR
FAN GRILLE GUARD

EVAPORATOR
FRONT COVER

EVAPORATOR
BOTTOM COVER

② EVAPORATOR, FAN MOTOR, DEFROST HEATER, SENSORS

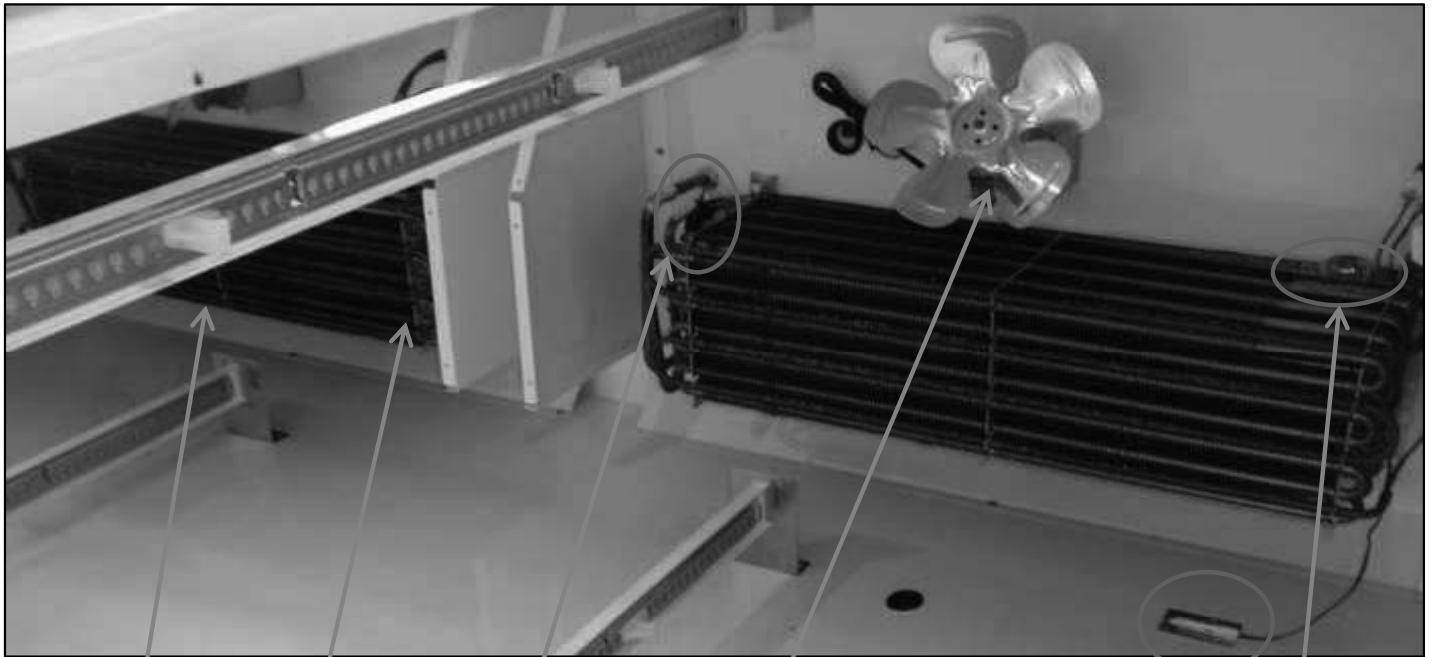

DEFROST HEATER

EVAPORATOR
FAN MOTOR & BLADE

THERMAL
FUSE

EVAPORATOR COIL

DEFROST SENSOR

F-SENSOR
(TEMPERATURE CONTROL)

PART DETAILS

③ COMPRESSOR & FAN MOTOR



CONDENSER

CONDENSER
FAN MOTOR

COMPRESSOR

WIRING DIAGRAM

3-3. TGM-10SD*, TGM-12SD*

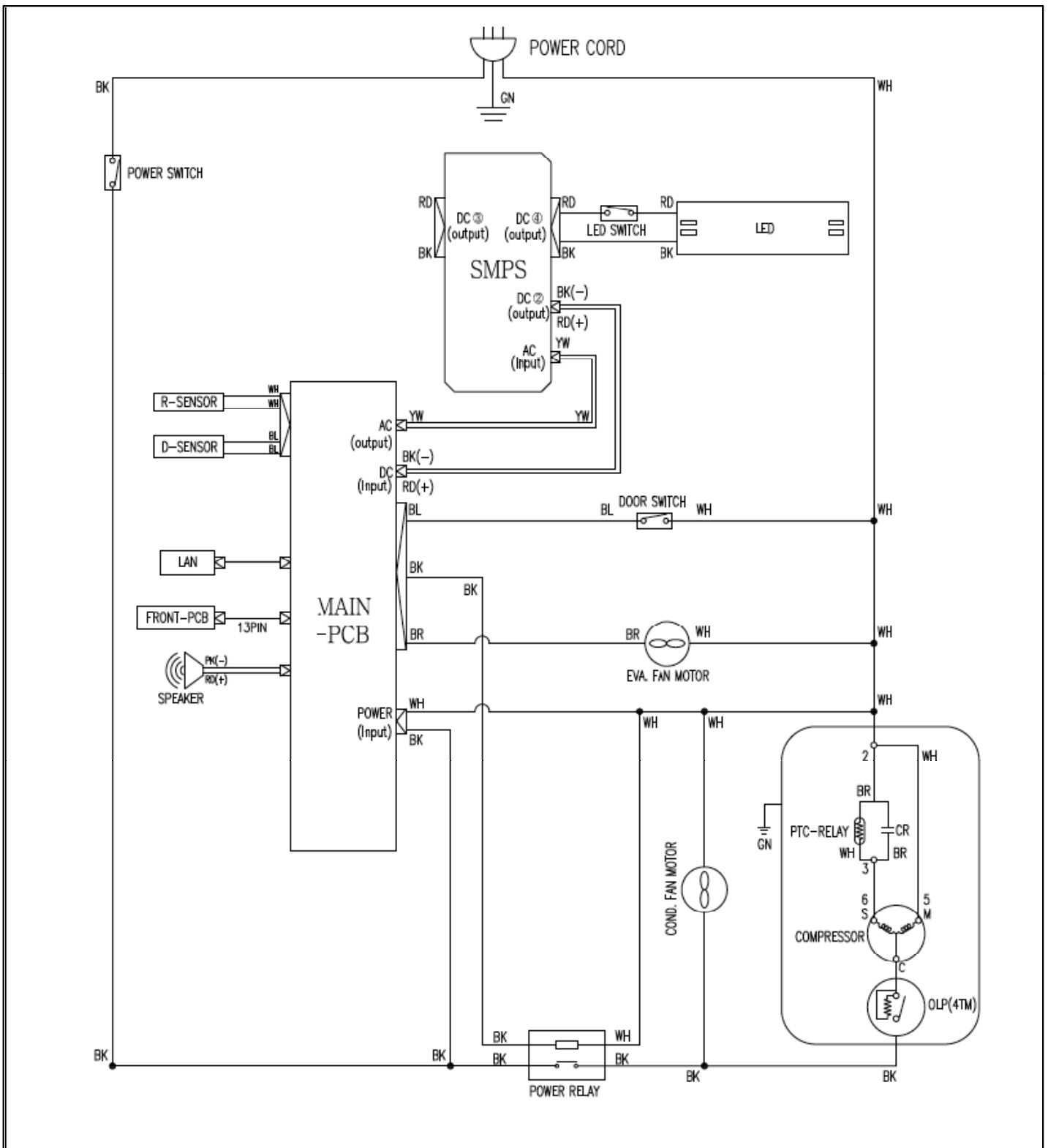

WIRING DIAGRAM

3-4. TGF-10SD*

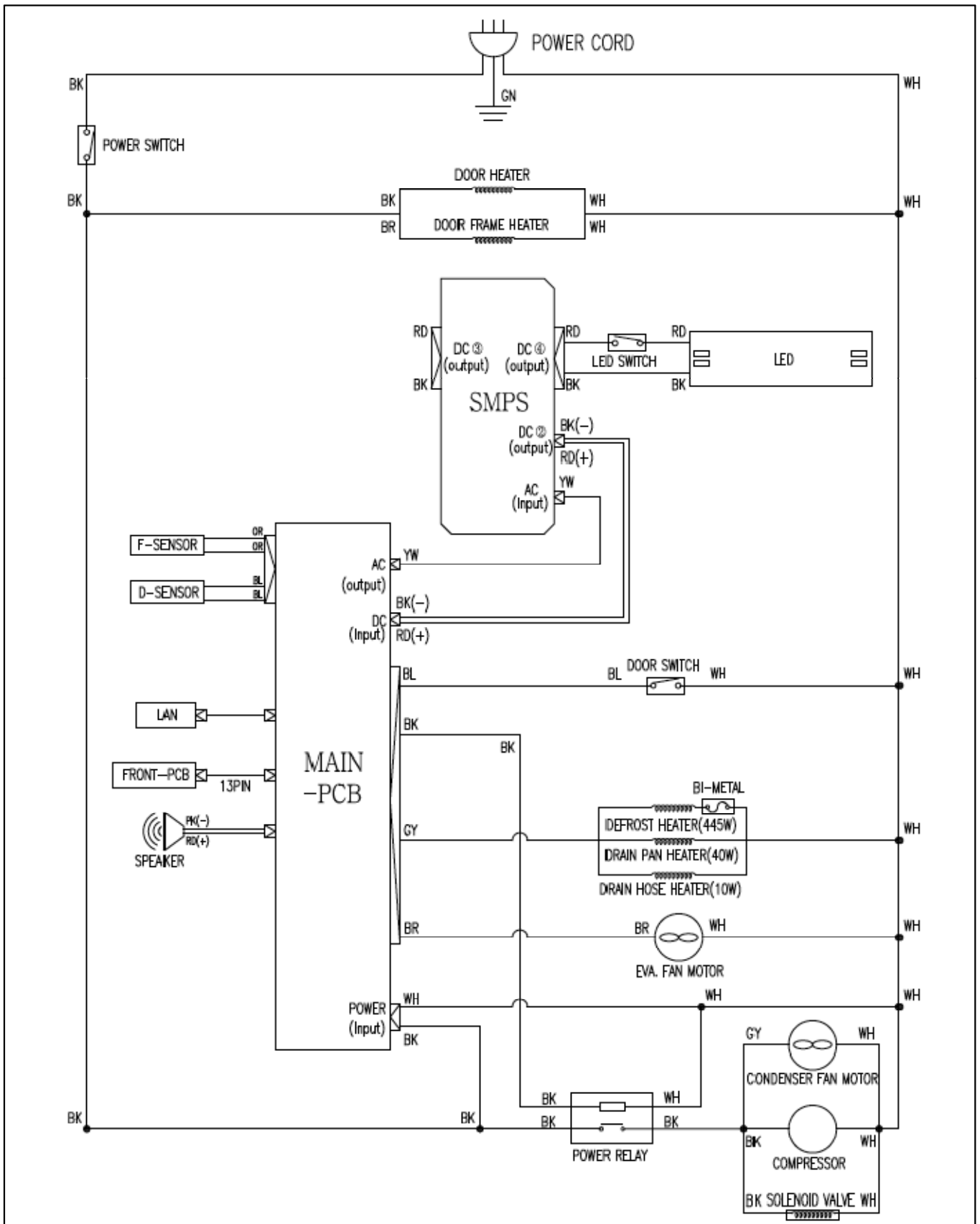

WIRING DIAGRAM

3-6. TGF-15SD*, TGF-23SD*

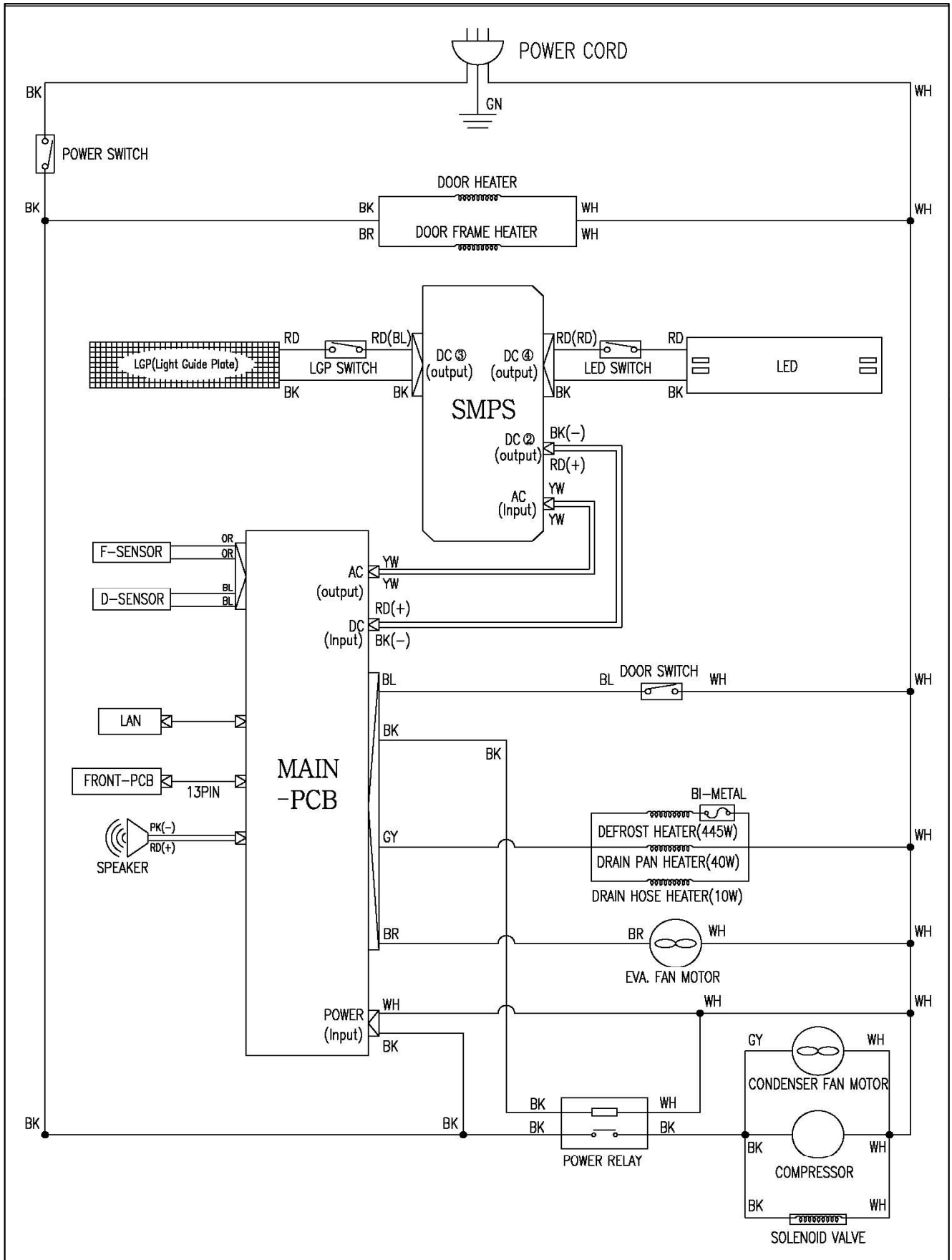

WIRING DIAGRAM

3-7. TGM-35SD*

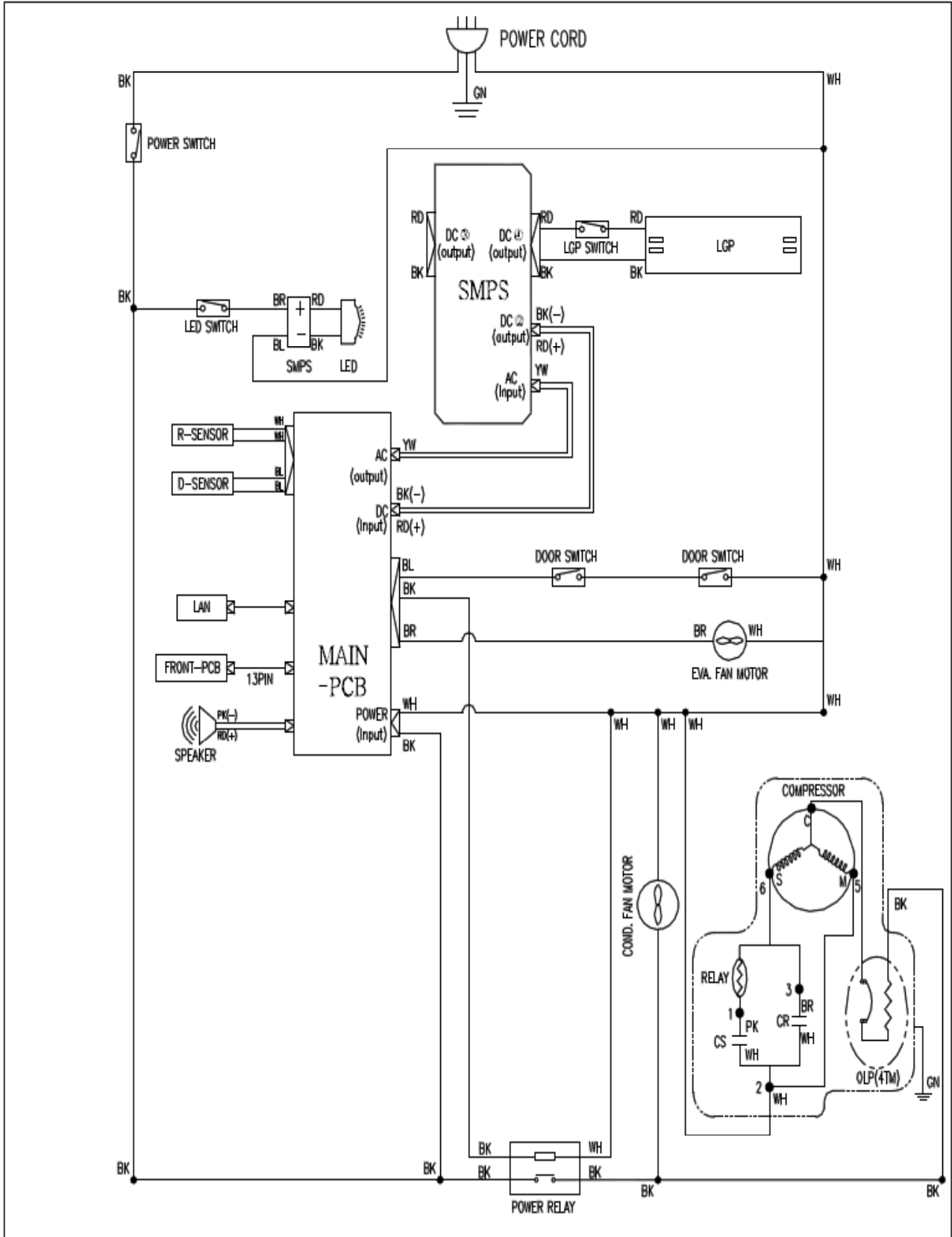

WIRING DIAGRAM

3-8. TGF-35SD*

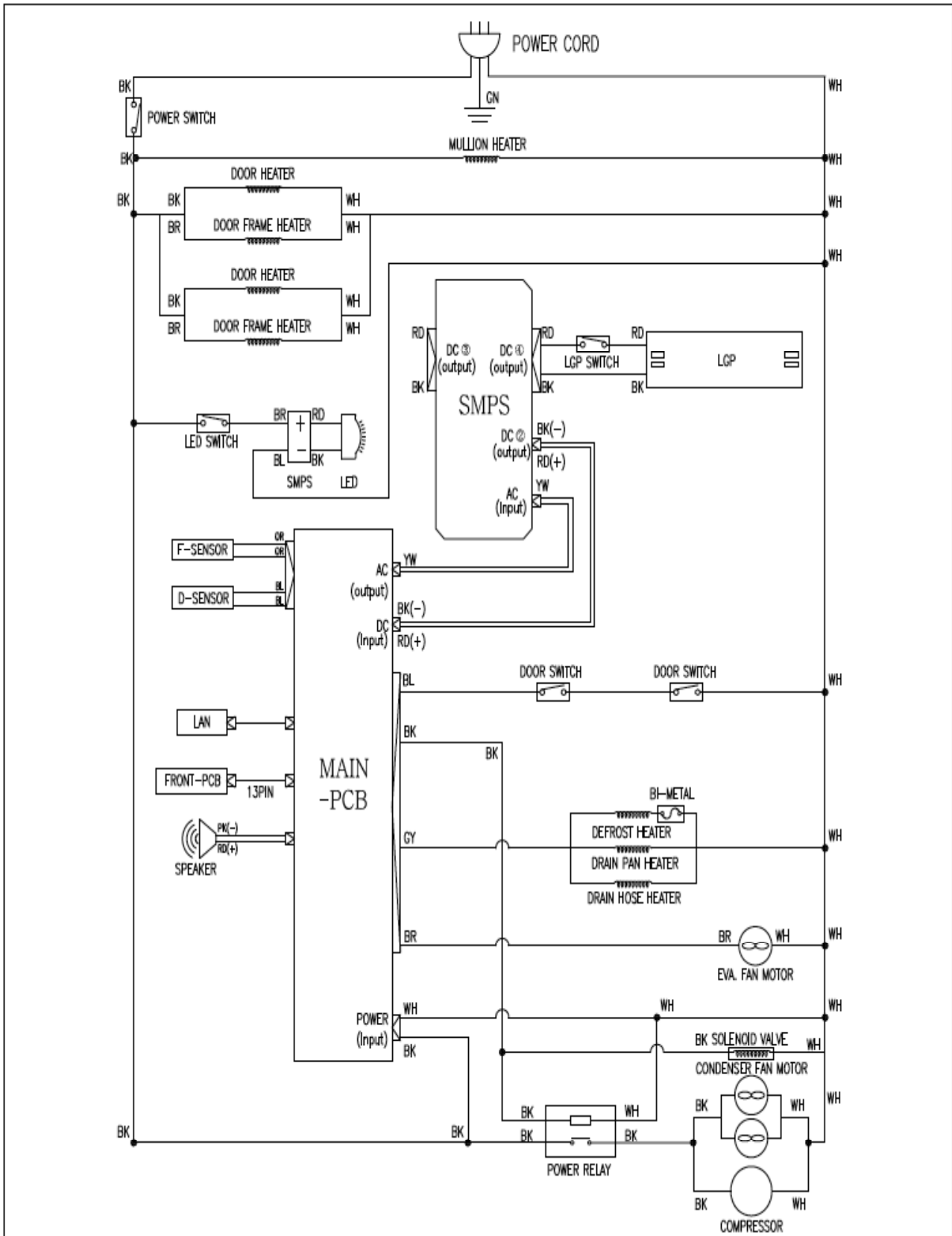

WIRING DIAGRAM

3-9. TGM-47SD*

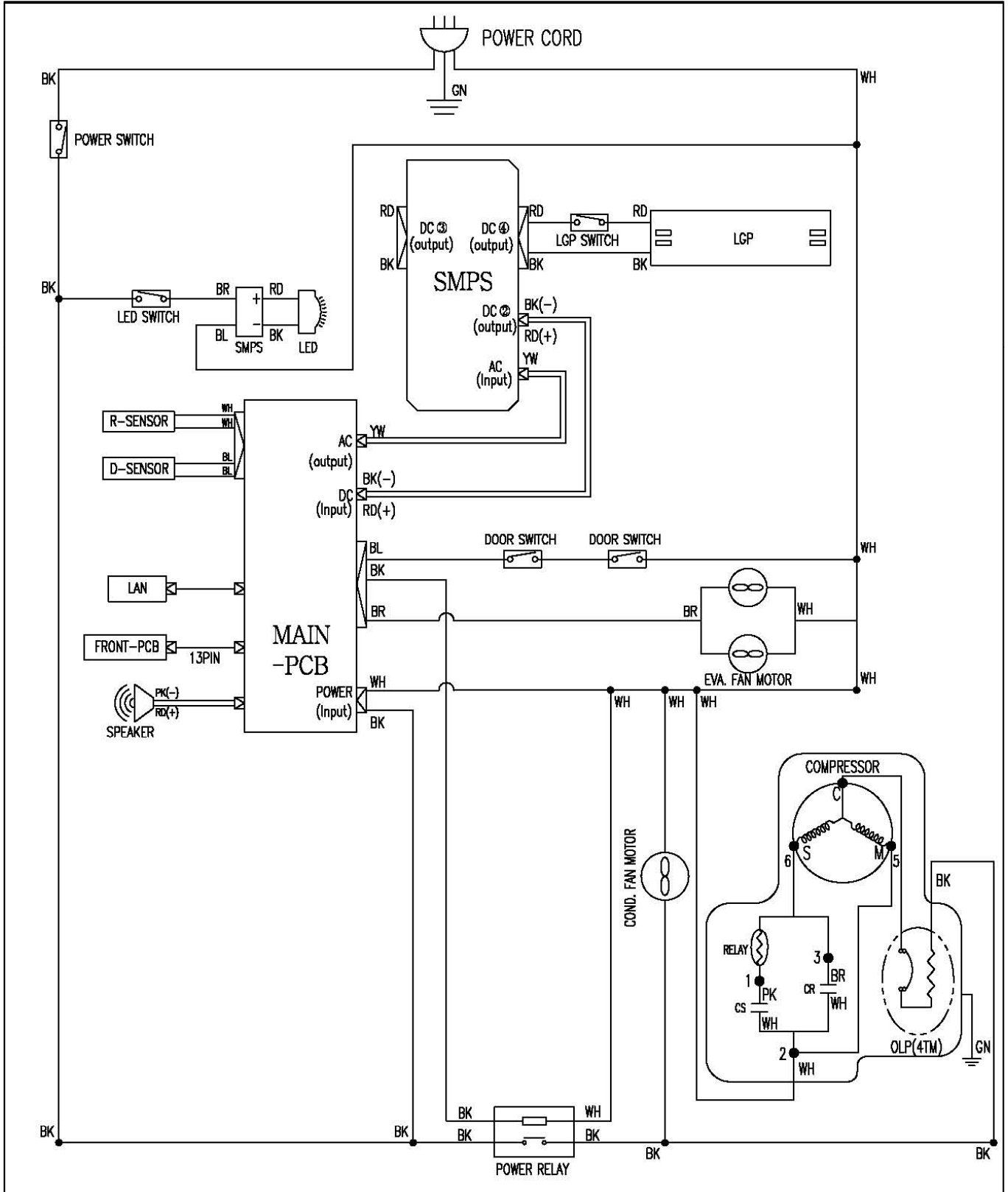

WIRING DIAGRAM

3-10. TGF-47SD*

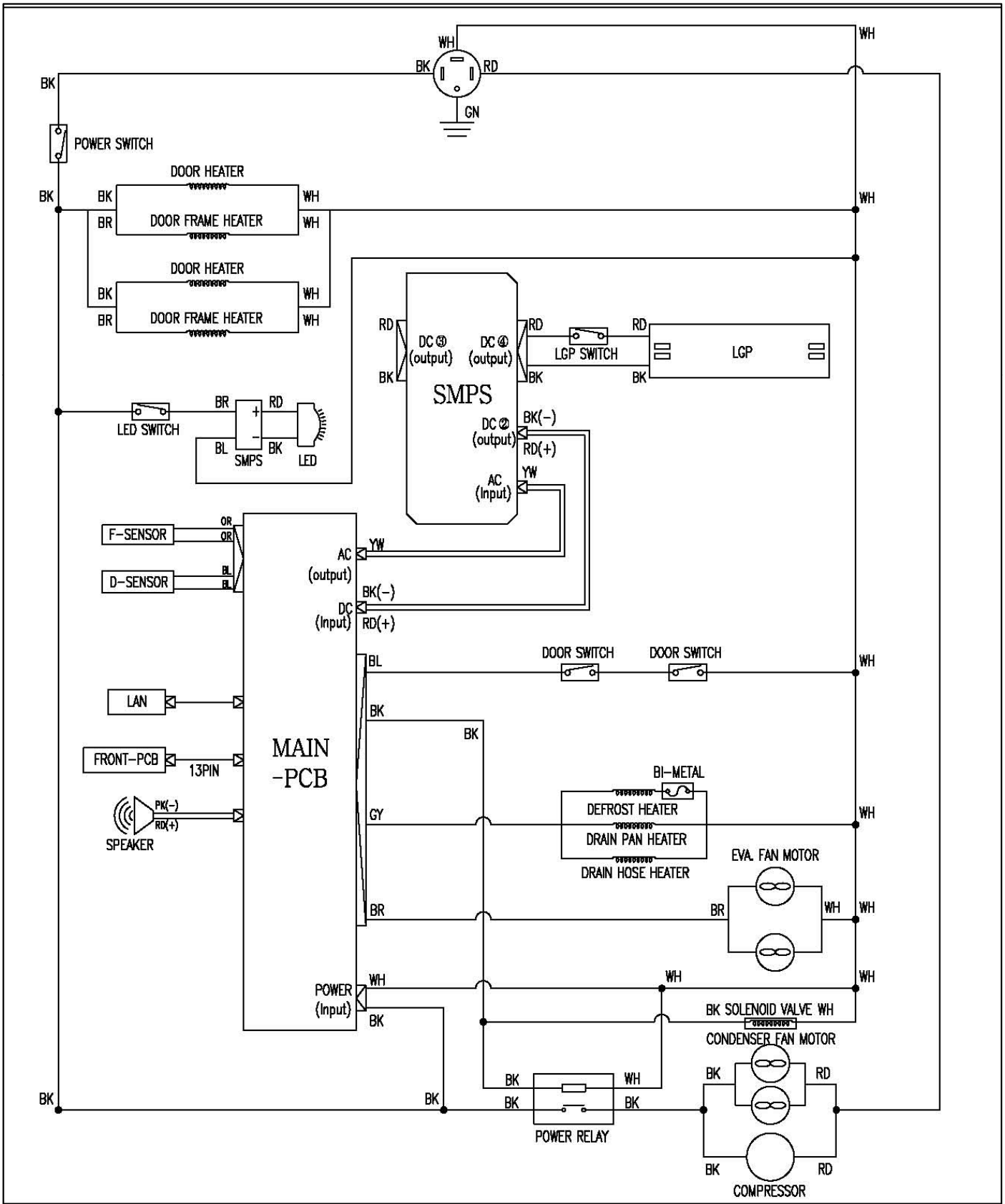

WIRING DIAGRAM

3-11. TGM-72SD*

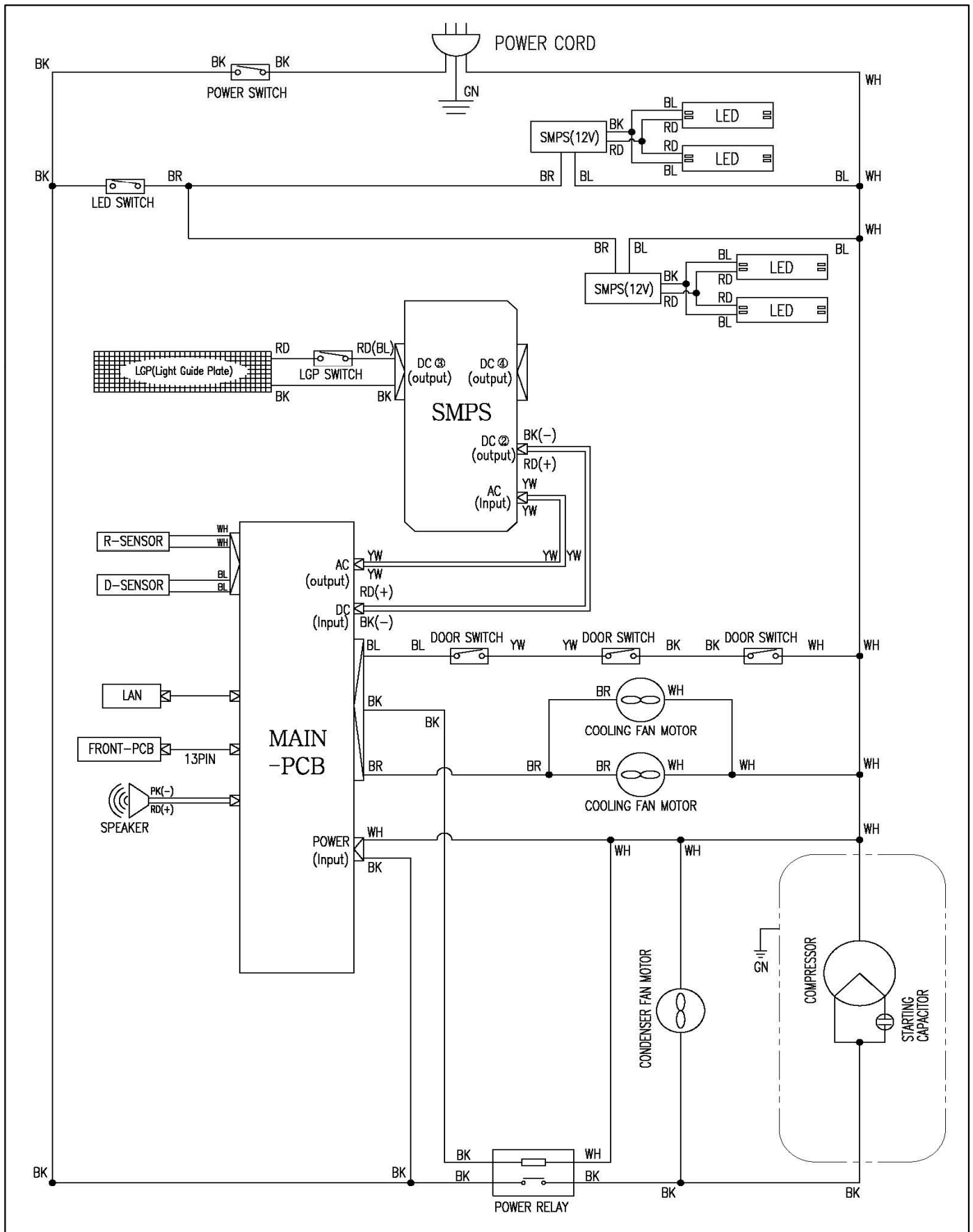

WIRING DIAGRAM

3-12. TGF-72SD*

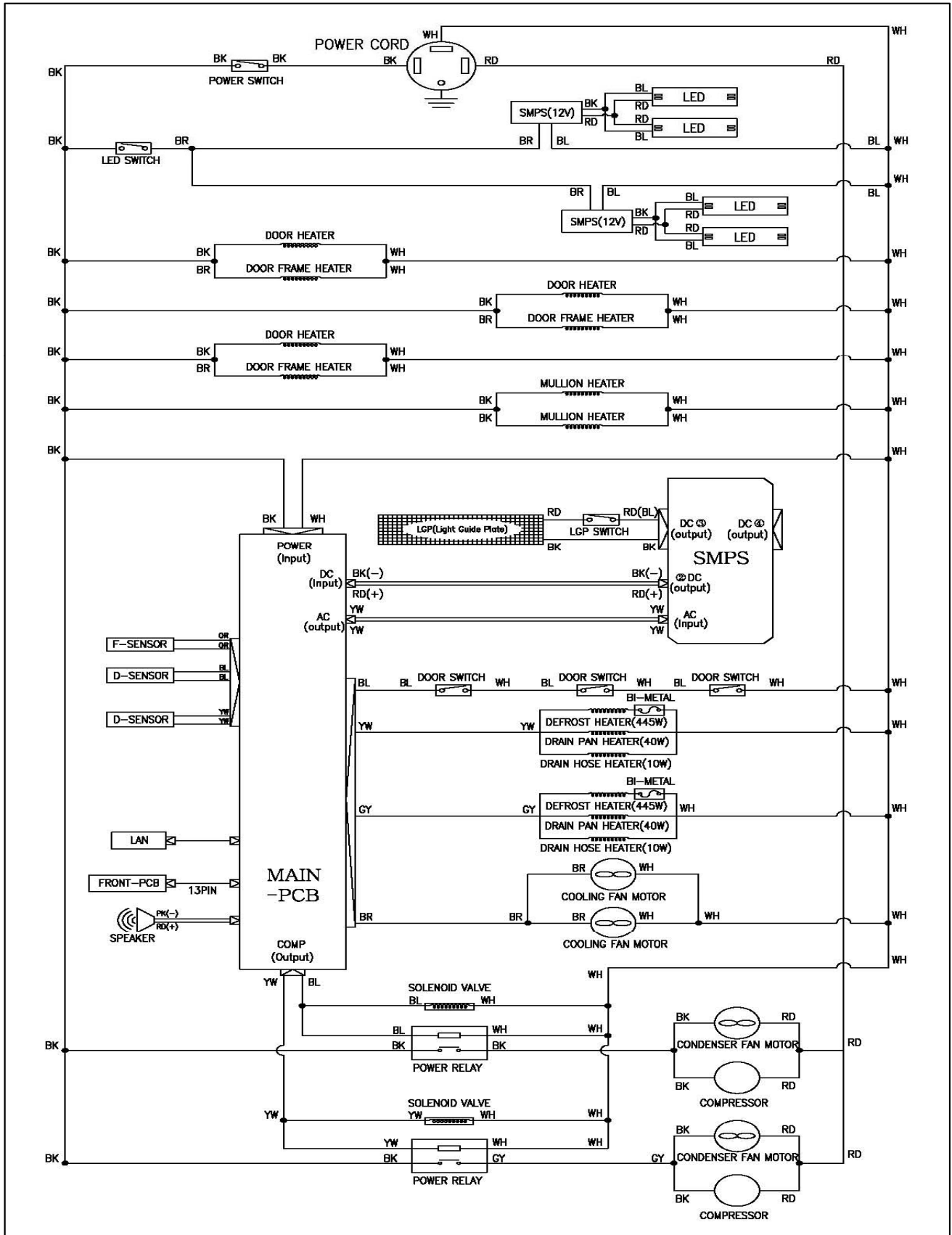

4. SPECIFICATION OF MAIN COMPONENTS

4-1. COMPRESSOR

MODEL	PART NAME	PART NO.	HORSE POWER	CAPACITY	TYPE OF MOTOR	Current (RLA)	Voltage Hz	MAKER
TGM-5SD* TGM-7SD* TGF-5SD*	MSA151D-L1B	P0189A0100	1/6 HP	603 BTU/h (152 Kcal/h)	LBP RSCR	1.03A	115V 60Hz	SAMSUNG
TGM-10SD* TGM-12SD* TGM-15SD* TGM-20SD* TGM-23SD*	MK183D-L2UB	30289R0100	1/4 HP	1,203 BTU/h (303 Kcal/h)	LBP CSR	1.98A	115V 60Hz	SAMSUNG
TGM-35SD* TGM-47SD*	SK1A1C-L2W	30200Q1200	1/3 HP	1,203 BTU/h (303 Kcal/h)	LBP CSR	3.85A	115V 60Hz	SAMSUNG
TGM-72SD*	T6217Z	3020014570	2/3 HP	7,638 BTU/h (1,925 Kcal/h)	HBP CSIR	10.48A	115V 60Hz	EMBRACO
TGF-5SD*	AEZ2415Z	30200N4400	1/3 HP	1,459 BTU/h (368 Kcal/h)	LBP CSIR	4.5A	115V 60Hz	TECUMSEH
TGF-10SD* TGF-15SD*	CAE2420Z	30200R1100	1/2 HP	2,268 BTU/h (572 Kcal/h)	LBP CSIR	6.6A	115V 60Hz	TECUMSEH
TGF-23SD*	CAJ2432Z	30200R1000	2/3 HP	3,200 BTU/h (807 Kcal/h)	LBP CSR	7.0A	115V 60Hz	TECUMSEH
TGF-35SD*	NJ2192GK	P0189A0200	1 1/4HP	4,500 BTU/h (1,134 Kcal/h)	LBP CSR	4.8A	115V 60Hz	EMBRACO
TGF-47SD* TGF-72SD*	CAJ2446Z	30200Q3600	1 HP	4,800 BTU/h (1,213 Kcal/h)	LBP CSR	4.8A	220V 60Hz	TECUMSEH

4-2. COMPRESSOR RELAY & OVERLOAD PROTECTOR

COMPRESSOR	RELAY	PART NO.	OVERLOAD	PART NO.	MAKER	NOTE
MSA151D-L1B	100MD2	-	SM308RHB-U1	-	SAMSUNG	
MK183D-L2UB	6R8MD2	-	4TM-445PHBZZ	-	SAMSUNG	
SK1A1C-L2W	22Ω-3PIN	-	4TM-795TFBZZ	-	SAMSUNG	
T6217Z	9660C-3027	-	MRT00AF	-	EMBRACO	
AEZ2415Z	KPF479	-	AE85FLY*	-	TECUMSEH	
CAE2420Z	3ARR12	-	T0889	-	TECUMSEH	
CAJ2432Z	3ARR3*5**	-	GA3PJU00	-	TECUMSEH	
NJ2192GK	3ARR3B3P3	-	15HM2442-168	-	EMBRACO	
CAJ2446Z	MST00AHZ	-	MST00AHZ or T0594	-	TECUMSEH	

MAIN COMPONENTS

4-3. COMPRESSOR CAPACITOR

MODEL	STARTING	PART NO.	RUNNING	PART NO.	MAKER	NOTE
TGM-5SD* TGM-7SD*	-	-	250V/12 μ F	-	SAMSUNG	
TGM-10SD* TGM-12SD* TGM-15SD* TGM-20SD* TGM-23SD*	-	-	250V/12 μ F	-	SAMSUNG	
TGM-35SD* TGM-47SD*	125V/125 μ F	30264L0200	250V/12 μ F	30264L0100	SAMSUNG	
TGM-72SD	330V/189-227 μ F	-	-	-	EMBRACO	
TGF-5SD*	160V/250 μ F	-	-	-	TECUMSEH	
TGF-10SD* TGF-15SD*	160V/315 μ F	-	-	-	TECUMSEH	
TGF-23SD*	160V/315 μ F	-	400V/30 μ F	-	TECUMSEH	
TGF-35SD*	125V/400 μ F	-	440V/20 μ F	-	EMBRACO	
TGF-47SD*	330V/125 μ F	-	400V/20 μ F	-	EMBRACO	
TGF-72SD*	250V/88 μ F	-	400V/15 μ F	-	TECUMSEH	

4-4. CONDENSER FAN MOTOR

MODEL	PART NAME	PART NO.	Quantity	BLADE	SIZE	MAKER
TGM-5SD* TGM-7SD*	DAI-6202DWSUA	P0191A0200	1EA	ZITEL 3	150mm	DAI-YOUNG
TGF-5SD*	DAI-8204DWSUA	P0191Q0200	1EA	AL 5	175mm	DAI-YOUNG
TGM-10SD* TGM-12SD* TGM-15SD* TGF-10SD* TGF-15SD*	DAI-8204DWSUA	P0191Q0200	1EA	AL 4	200mm	DAI-YOUNG
TGM-23SD* TGF-23SD* TGM-47SD* TGM-72SD*	DAI-8204DWSUA	P0191Q0200	1EA	AL 4	250mm	
TGM-35SD*	DAI-8204DWSUA	P0191Q0200	1EA	AL 4	225mm	DAI-YOUNG
TGF-35SD*	DAI-8204DWSUA	P0191Q0200	2EA	AL 4	225mm	
TGF-47SD*	DAI-8204DWSQ-1	3963336200	2EA	AL 4	225mm	
TGF-72SD*	DAI-8204DWSQ-1	3963336200	2EA	AL 4	250mm	

MAIN COMPONENTS

4-5. EVAPORATOR FAN MOTOR

MODEL	PART NAME	PART NO.	Quantity	BLADE	SIZE	MAKER
TGM-5SD* TGM-7SD* TGF-5SD*	DAI-6202DWSUA-1	P0191A0100	1EA	ZITEL 6	150mm	DAI-YOUNG
TGM-10SD* TGM-12SD* TGM-15SD* TGM-20SD* TGM-23SD* TGF-10SD* TGF-15SD* TGF-23SD*	DAI-8154DWSUA	P0191Q0100	1EA	AL 5	175mm	DAI-YOUNG
TGM-35SD* TGF-35SD*	DAI-8154DWSUA	P0191Q0100	1EA	AL4	200mm	DAI-YOUNG
TGM-47SD* TGM-72SD* TGF-47SD*	DAI-8154DWSUA	P0191Q0100	2EA	AL 5	175mm	DAI-YOUNG
TGF-72SD*	DAI-8154DWSUA	P0191Q0100	2EA	AL 4	200mm	DAI-YOUNG

4-6. EVAPORATOR DEFROST HEATER

MODEL	PART NAME	PART NO.	SPEC	Quantity	MAKER
TGF-5SD*	SHEATH HEATER	P0128U0100	200W	1EA	SANG-DO
TGF-10SD* TGF-15SD*		P0128U0200	200W	1EA	
TGF-23SD*		30228L0803	445W	1EA	
TGF-35SD* TGF-47SD*		30228L00701	600W	1EA	
TGF-72SD*		30228L00701	600W	2EA	

MAIN COMPONENTS

4-7. SMPS

MODEL	APPLICATION	PART NAME	SPEC	PART NO.	QTY	MAKER
TGM-5SD* TGM-7SD* TGF-5SD*	INTERIOR	SMPS	LPV-20-12(12V)	30284R0500	1	MEAN WELL
TGM-10SD* TGM-12SD* TGM-15SD* TGM-20SD* TGM-23SD* TGF-10SD* TGF-15SD* TGF-23SD*	INTERIOR SIGN PANEL	SMPS	SM40W115	30284R1100	1	NEUROSYS
TGM-35SD* TGF-35SD* TGM-47SD* TGF-47SD*	INTERIOR SIGN PANEL	SMPS SMPS	LPV-60-12(12V) SM40W115	30284R0700 30284R1100	1 1	MEAN WELL NEUROSYS
TGM-72SD* TGF-72SD*	INTERIOR SIGN PANEL	SMPS SMPS	LPV-60-12(12V) SM40W115	30284R0700 30284R1100	2 1	MEAN WELL NEUROSYS

4-8. LED & LIGHT GUIDE PANEL

MODEL	APPLICATION	PART NAME	SPEC	PART NO.	QTY	BULB
TGM-5SD* TGM-7SD* TGF-5SD*	INTERIOR	LED	10W-12V	P0136A0101	1	-
TGM-10SD* TGM-12SD* TGF-10SD*	INTERIOR	LED	14W-12V	P0136A0100	1	-
TGM-15SD*	INTERIOR SIGN PANEL	LED LIGHT GUIDE PANEL	19W-12V 8.28W-12V	30236R2200 P0142U4000	1 1	- -
TGM-20SD* TGM-23SD* TGF-23SD*	INTERIOR SIGN PANEL	LED LIGHT GUIDE PANEL	19W-12V 8.64W-12V	30236R2200 P0142U4100	1 1	- -
TGM-35SD* TGF-35SD*	INTERIOR SIGN PANEL	LED LIGHT GUIDE PANEL	19W-12V 16.44W-12V	30236R2200 P0142U4200	2 1	- -
TGM-47SD* TGF-47SD*	INTERIOR SIGN PANEL	LED LIGHT GUIDE PANEL	19W-12V 16.44W-12V	30236R2200 P0142U4300	2 1	- -
TGM-72SD* TGF-72SD*	INTERIOR SIGN PANEL	LED LIGHT GUIDE PANEL	19W-12V 25.68W-12V	30236R2200 P0142U4400	4 1	- -

MAIN COMPONENTS

4-9. POWER SWITCH & LAMP SWITCH

MODEL		SPEC	PART NO.	QTY	MAKER
TGM-5SD* TGM-7SD* TGM-10SD* TGM-12SD* TGF-5SD* TGF-10SD	POWER	R19A(RA15)	30281Q0101	1	LIGHT CONTRY
	INTERIOR			1	
TGM-15SD* TGM-20SD* TGM-23SD* TGF-23SD* TGM-35SD* TGF-35SD* TGM-47SD* TGF-47SD* TGM-72SD* TGF-72SD*	POWER	R19A(RA15)	30281Q0101	1	
	INTERIOR			1	
	SIGN PANEL			1	

4-10. DOOR SWITCH

MODEL	PART NAME	SPEC	PART NO.	QTY	MAKER
TGM-5SD* TGM-7SD* TGM-10SD* TGM-12SD* TGF-5SD* TGF-10SD*	DOOR SWITCH	DSD-6	P0181L0200	1	DAE-HAN
TGM-15SD* TGM-20SD* TGM-23SD* TGF-23SD*	DOOR SWITCH	E31001CA	30281R0101	1	ARCOLETRIC
TGM-35SD* TGF-35SD* TGM-47SD* TGF-47SD*	DOOR SWITCH	E31001CA	30281R0101	2	
TGM-72SD* TGF-72SD*	DOOR SWITCH	E31001CA	30281R0101	3	

MAIN COMPONENTS

4-11. MAIN PCB

MODEL	PART NAME	SPEC	PART NO.	MAKER
TGM-10SD* TGF-12SD*	MAIN PCB	SGRF1153	30243R1200	NEUROSYS
TGM-15SD* TGM-23SD* TGM-35SD* TGM-47SD* TGM-72SD* TGM-35SD*	MAIN PCB	GRF1152	30243R0600	
TGF-10SD*	MAIN PCB	SGFF1152	30243R1300	
TGF-23SD* TGF-35SD* TGF-47SD*	MAIN PCB	GFF1152	30243R0700	
TGF-72SD* TGF-35SD*	MAIN PCB	2GFF1152	P0143K0100	

5. MAIN PCB PROGRAMING

5-1 SD REFRIGERATOR CONTROLLER

- ▶ TGM-10SD*, TGM-12SD*, TGM-15SD*, TGM-20SD*, TGM-23SD*, TGM-35SD*, TGM-47SD*, TGM-72SD*

5-1-1. HOW TO USE THE DISPLAY PANEL

- The default temperature setting is 37°F.
- The operating temperature is between 50°F and 30°F, which can be adjusted by using the (-) and (+) keys.

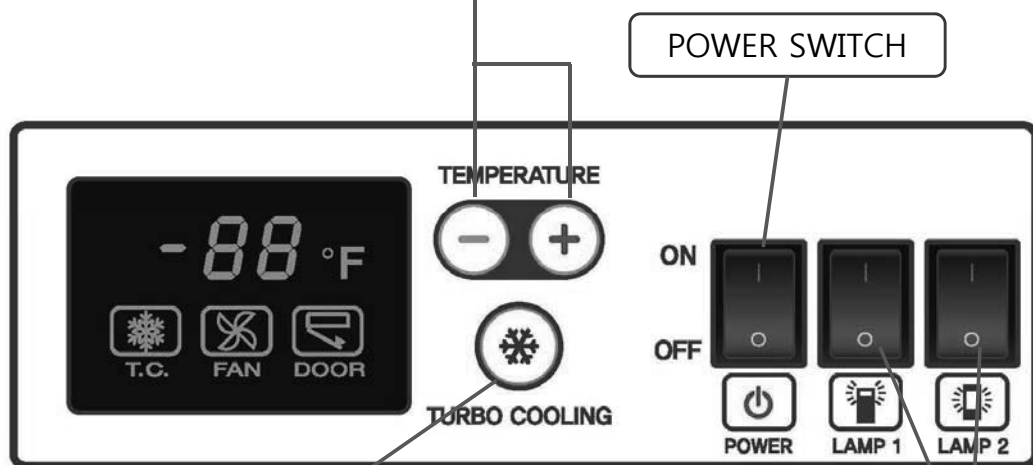

- The compressor continuously operates for 120 minutes under 'TURBO COOLING' mode.
- Press 'TURBO COOLING' button again to deactivate 'TURBO COOLING' mode.

LAMP SWITCH

MAIN PCB PROGRAMING

5-1-2. FUNCTION TABLE

No	Control Function	Control Objects	Description																																																																																										
1	Initial Operation	Buzzer Fan Lamp 88 LED	<ol style="list-style-type: none"> Buzzer will be sound within 2 seconds after the power is turned on. 88 LED displays the temperature value inside the appliance. Compressor will run if evaporator's temperature is higher than 38.3°F(3.5°C). Once powered, compressor will not run for 3 minutes. If the temperature in a cooler is lower than -40°F or higher than 99°F, 88 LED will display 'LO' or 'HI' respectively. 																																																																																										
2	Temperature Control	Compressor Evap. Fan Motor Cond. Fan Motor 88 LED	<ol style="list-style-type: none"> You can set the desired temperature from 50°F to 30°F by using the (-) or (+) keys 88 LED will display a setting temperature when you push the (-) or (+) keys 88 LED will indicate real temperature after setting the value. Buzzer will sound once whenever each button is pressed. Compressor will automatically adjust to on or off cycle, relative to the return air detection of R-sensor Compressor will not run for 5 minutes after the off cycle even though R-sensor is in its operational range. Evaporator Fan Motor will run continuously when compressor is running except when the door is opened. Evaporator Fan Motor will stop for 3 minutes and then will run for a minutes repeatedly when compressor is stopped. Evaporator Fan Motor will run within 3 seconds after the doors are closed. Compressor On/Off Temperature(°F) <table border="1" style="width: 100%; border-collapse: collapse;"> <tbody> <tr> <td>Setting Value(°F)</td> <td>50</td> <td>49</td> <td>48</td> <td>47</td> <td>46</td> </tr> <tr> <td>Comp On(°F)</td> <td>55.4</td> <td>54.4</td> <td>53.4</td> <td>52.4</td> <td>51.4</td> </tr> <tr> <td>Comp Off(°F)</td> <td>44.6</td> <td>43.6</td> <td>42.6</td> <td>41.6</td> <td>40.6</td> </tr> <tr> <td>Setting Value(°F)</td> <td>45</td> <td>44</td> <td>43</td> <td>42</td> <td>41</td> </tr> <tr> <td>Comp On(°F)</td> <td>50.4</td> <td>49.4</td> <td>48.4</td> <td>47.4</td> <td>46.4</td> </tr> <tr> <td>Comp Off(°F)</td> <td>39.6</td> <td>38.6</td> <td>37.6</td> <td>36.6</td> <td>35.6</td> </tr> <tr> <td>Setting Value(°F)</td> <td>40</td> <td>39</td> <td>38</td> <td>37</td> <td>36</td> </tr> <tr> <td>Comp On(°F)</td> <td>45.4</td> <td>44.4</td> <td>43.4</td> <td>42.4</td> <td>41.4</td> </tr> <tr> <td>Comp Off(°F)</td> <td>34.6</td> <td>33.6</td> <td>32.6</td> <td>31.6</td> <td>30.6</td> </tr> <tr> <td>Setting Value(°F)</td> <td>35</td> <td>34</td> <td>33</td> <td>32</td> <td>31</td> </tr> <tr> <td>Comp On(°F)</td> <td>40.4</td> <td>39.4</td> <td>38.4</td> <td>37.4</td> <td>36.4</td> </tr> <tr> <td>Comp Off(°F)</td> <td>29.6</td> <td>28.6</td> <td>27.6</td> <td>26.6</td> <td>25.6</td> </tr> <tr> <td>Setting Value(°F)</td> <td>30</td> <td></td> <td></td> <td></td> <td></td> </tr> <tr> <td>Comp On(°F)</td> <td>35.4</td> <td></td> <td></td> <td></td> <td></td> </tr> <tr> <td>Comp Off(°F)</td> <td>24.6</td> <td></td> <td></td> <td></td> <td></td> </tr> </tbody> </table>	Setting Value(°F)	50	49	48	47	46	Comp On(°F)	55.4	54.4	53.4	52.4	51.4	Comp Off(°F)	44.6	43.6	42.6	41.6	40.6	Setting Value(°F)	45	44	43	42	41	Comp On(°F)	50.4	49.4	48.4	47.4	46.4	Comp Off(°F)	39.6	38.6	37.6	36.6	35.6	Setting Value(°F)	40	39	38	37	36	Comp On(°F)	45.4	44.4	43.4	42.4	41.4	Comp Off(°F)	34.6	33.6	32.6	31.6	30.6	Setting Value(°F)	35	34	33	32	31	Comp On(°F)	40.4	39.4	38.4	37.4	36.4	Comp Off(°F)	29.6	28.6	27.6	26.6	25.6	Setting Value(°F)	30					Comp On(°F)	35.4					Comp Off(°F)	24.6				
Setting Value(°F)	50	49	48	47	46																																																																																								
Comp On(°F)	55.4	54.4	53.4	52.4	51.4																																																																																								
Comp Off(°F)	44.6	43.6	42.6	41.6	40.6																																																																																								
Setting Value(°F)	45	44	43	42	41																																																																																								
Comp On(°F)	50.4	49.4	48.4	47.4	46.4																																																																																								
Comp Off(°F)	39.6	38.6	37.6	36.6	35.6																																																																																								
Setting Value(°F)	40	39	38	37	36																																																																																								
Comp On(°F)	45.4	44.4	43.4	42.4	41.4																																																																																								
Comp Off(°F)	34.6	33.6	32.6	31.6	30.6																																																																																								
Setting Value(°F)	35	34	33	32	31																																																																																								
Comp On(°F)	40.4	39.4	38.4	37.4	36.4																																																																																								
Comp Off(°F)	29.6	28.6	27.6	26.6	25.6																																																																																								
Setting Value(°F)	30																																																																																												
Comp On(°F)	35.4																																																																																												
Comp Off(°F)	24.6																																																																																												
3	Turbo Cooling	Compressor Evap. Fan Motor Cond. Fan Motor 88 LED	<ol style="list-style-type: none"> If the 'Turbo Cooling' button is pressed, the 'Turbo Cooling' mode will start. If the 'Turbo Cooling' button is pressed again during 'Turbo Cooling' mode, the turbo cooling mode will be cancelled. 'TURBO COOLING' mode activates uninterrupted decrease in temperature; the (-) or (+) keys will not be operational 88 LED will continuously flash 'T.C' during 'Turbo Cooling' mode. The compressor & condenser fan motor will operate for 120 minutes. 																																																																																										

MAIN PCB PROGRAMING

No	Control Fuction	Control Objects	Description
3	Turbo Cooling	Compressor Evap. Fan Motor Cond. Fan Motor 88 LED	6. If the 'Turbo Cooling' button is pressed under defrost mode, 88 LED will flash 'T.C'; however, 'Turbo Cooling' mode will start after defrost mode is terminated. 7. If defrost mode occurs during 'Turbo Cooling' mode, the defrost mode will start after the turbo Cooling mode is terminated.
4	Determination of Defrost		1. The First Defrost mode will start at the 6 hours have passed after the power switch is on. 2. The Defrost mode will be initiated when 16 hours have passed since the last defrost mode was terminated.
5	Defrost Function	Compressor Evap. Fan Motor Cond. Fan Motor	1. If it becomes defrost cycle time, the refrigerator will execute defrost function. 2. Defrost method is to operate Evaporator Fan Motor with compressor is off. 3. Defrost mode is terminated when Defrost sensor's temperature comes to above 45°F(7.0°C) 4. It will display "dF" when Defrost mode is started. 5. Maximum defrost time is 40 minutes. 6. If D-sensor's temp. doesn't reach 50°F(10°C) in 40 min., error code will be recorded on a MICOM.
6	Manual Defrost	Compressor Evap. Fan Motor Cond. Fan Motor	1. Press the both up/down (or +/-) keys for 5 seconds. 88 LED should display "SL". 2. Press the down(or -) button. 88 LED display "dS". 3. Press the down(or -) button. 88 LED display "dF" and defrost mode start. 4. The next procedure is the same as that of defrost mode.
7	Comp Restart Prevent	Compressor Cond. Fan Motor	A. Compressor will not run for 5 minutes after off cycle even if R-sensor is in its operatinal range.
8	Power Failure Back up Function	Compressor Evap. Fan Motor Cond. Fan Motor	A. Compressor will not be run for 5 minutes after power failure. B. Only Evap. Fan Motor is ON.
9	Door Open Alarm Function	Buzzer 88 LED	A. The LED Display panel will read 'DOOR' icon and will not flash 'FAN' icon. B. Before sounding the beeper: 1. Door was open for more than 30 seconds, the buzzer will sound 3 times. 2. Door was open for more than 60 seconds, the buzzer will sound 5 times. 3. Door was open for more than 5 minutes, the buzzer will continuously sound.
10	Buzzer Function	Buzzer	A. Beep sound rings once after initial power up. B. Beep sound rings whenever each button is pressed. C. If the door stays open past a certain amount of time, beeping will occur. (see door open alarm function)

5-2 SD FREEZER CONTROLLER

► TGF-10SD*, TGF-15SD* TGF-23SD*, TGF-35SD*, TGF-47SD*, TGF-72SD*

5-2-1. HOW TO USE THE DISPLAY PANEL

- The default temperature setting is -8°F.
- The operating temperature is between 5°F and -17°F, which can be adjusted by using the (-) and (+) keys.

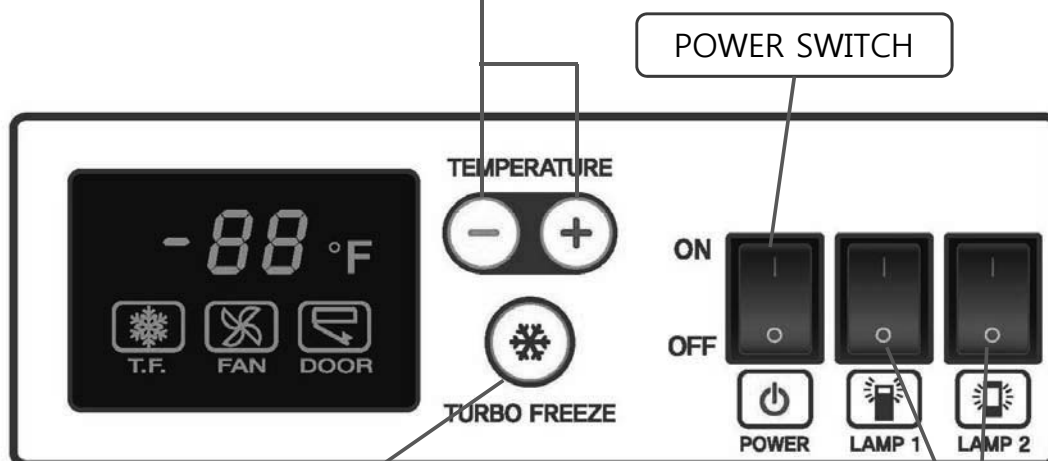

- The compressor continuously operates for 120 minutes under 'TURBO FREEZE' mode.
- Press 'TURBO FREEZE' button again to deactivate 'TURBO FREEZE' mode.

MAIN PCB PROGRAMING

5-2-2. FUNCTION TABLE

No	Control Function	Control Objects	Description																																																																																										
1	Initial Operation	Buzzer Fan Lamp 88 LED	<ol style="list-style-type: none"> Buzzer will be sound within 2 seconds after the power is turned on. 88 LED displays the temperature value inside the appliance. Compressor will run if evaporator's temperature is higher than 38.3°F(3.5°C). Once powered, compressor will not run for 3 minutes. If the temperature in a cooler is lower than -40°F or higher than 99°F, 88 LED will display 'LO' or 'HI' respectively. 																																																																																										
2	Temperature Control	Compressor Evap. Fan Motor Cond. Fan Motor 88 LED	<ol style="list-style-type: none"> You can set the desired temperature from 5°F to -17°F by using the (-) or (+) keys. 88 LED will display a setting temperature when you push the (-) or (+) keys. 88 LED will indicate real temperature after setting the value. Buzzer will sound once whenever each button is pressed. Compressor will automatically adjust to on or off cycle, relative to the return air detection of F-sensor . Compressor will not run for 5 minutes after the off cycle even though F-sensor is in its operatinal range. Evaporator Fan Motor will run continuously when compressor is running except when the door is opened. Evaporator Fan Motor will stop for a minutes and then will run for a minutes repeatedly when compressor is stopped. Evaporator Fan Motor will run within 3 seconds after the doors are closed. Compressor On/Off Temperature(°F) <table border="1" style="width: 100%; border-collapse: collapse;"> <tbody> <tr> <td>Setting Value(°F)</td> <td>5</td> <td>4</td> <td>3</td> <td>2</td> <td>1</td> </tr> <tr> <td>Comp On(°F)</td> <td>10.4</td> <td>9.4</td> <td>8.4</td> <td>7.4</td> <td>6.4</td> </tr> <tr> <td>Comp Off(°F)</td> <td>-0.4</td> <td>-1.4</td> <td>-2.4</td> <td>-3.4</td> <td>-4.4</td> </tr> <tr> <td>Setting Value(°F)</td> <td>0</td> <td>-1</td> <td>-2</td> <td>-3</td> <td>-4</td> </tr> <tr> <td>Comp On(°F)</td> <td>5.4</td> <td>4.4</td> <td>3.4</td> <td>2.4</td> <td>1.4</td> </tr> <tr> <td>Comp Off(°F)</td> <td>-5.4</td> <td>-6.4</td> <td>-7.4</td> <td>-8.4</td> <td>-9.4</td> </tr> <tr> <td>Setting Value(°F)</td> <td>-5</td> <td>-6</td> <td>-7</td> <td>-8</td> <td>-9</td> </tr> <tr> <td>Comp On(°F)</td> <td>0.4</td> <td>-0.6</td> <td>-1.6</td> <td>-2.6</td> <td>-3.6</td> </tr> <tr> <td>Comp Off(°F)</td> <td>-10.4</td> <td>-11.4</td> <td>-12.4</td> <td>-13.4</td> <td>-14.4</td> </tr> <tr> <td>Setting Value(°F)</td> <td>-1</td> <td>-11</td> <td>-12</td> <td>-13</td> <td>-14</td> </tr> <tr> <td>Comp On(°F)</td> <td>4.4</td> <td>-5.6</td> <td>-6.6</td> <td>-7.6</td> <td>-8.6</td> </tr> <tr> <td>Comp Off(°F)</td> <td>-6.4</td> <td>-16.4</td> <td>-17.4</td> <td>-18.4</td> <td>-19.4</td> </tr> <tr> <td>Setting Value(°F)</td> <td>-15</td> <td>-16</td> <td>-17</td> <td></td> <td></td> </tr> <tr> <td>Comp On(°F)</td> <td>-9.6</td> <td>-10.6</td> <td>-11.6</td> <td></td> <td></td> </tr> <tr> <td>Comp Off(°F)</td> <td>-20.4</td> <td>-21.4</td> <td>-22.4</td> <td></td> <td></td> </tr> </tbody> </table>	Setting Value(°F)	5	4	3	2	1	Comp On(°F)	10.4	9.4	8.4	7.4	6.4	Comp Off(°F)	-0.4	-1.4	-2.4	-3.4	-4.4	Setting Value(°F)	0	-1	-2	-3	-4	Comp On(°F)	5.4	4.4	3.4	2.4	1.4	Comp Off(°F)	-5.4	-6.4	-7.4	-8.4	-9.4	Setting Value(°F)	-5	-6	-7	-8	-9	Comp On(°F)	0.4	-0.6	-1.6	-2.6	-3.6	Comp Off(°F)	-10.4	-11.4	-12.4	-13.4	-14.4	Setting Value(°F)	-1	-11	-12	-13	-14	Comp On(°F)	4.4	-5.6	-6.6	-7.6	-8.6	Comp Off(°F)	-6.4	-16.4	-17.4	-18.4	-19.4	Setting Value(°F)	-15	-16	-17			Comp On(°F)	-9.6	-10.6	-11.6			Comp Off(°F)	-20.4	-21.4	-22.4		
Setting Value(°F)	5	4	3	2	1																																																																																								
Comp On(°F)	10.4	9.4	8.4	7.4	6.4																																																																																								
Comp Off(°F)	-0.4	-1.4	-2.4	-3.4	-4.4																																																																																								
Setting Value(°F)	0	-1	-2	-3	-4																																																																																								
Comp On(°F)	5.4	4.4	3.4	2.4	1.4																																																																																								
Comp Off(°F)	-5.4	-6.4	-7.4	-8.4	-9.4																																																																																								
Setting Value(°F)	-5	-6	-7	-8	-9																																																																																								
Comp On(°F)	0.4	-0.6	-1.6	-2.6	-3.6																																																																																								
Comp Off(°F)	-10.4	-11.4	-12.4	-13.4	-14.4																																																																																								
Setting Value(°F)	-1	-11	-12	-13	-14																																																																																								
Comp On(°F)	4.4	-5.6	-6.6	-7.6	-8.6																																																																																								
Comp Off(°F)	-6.4	-16.4	-17.4	-18.4	-19.4																																																																																								
Setting Value(°F)	-15	-16	-17																																																																																										
Comp On(°F)	-9.6	-10.6	-11.6																																																																																										
Comp Off(°F)	-20.4	-21.4	-22.4																																																																																										
3	Turbo Freeze	Compressor Evap. Fan Motor Cond. Fan Motor 88 LED	<ol style="list-style-type: none"> If the 'Turbo Freeze' button is pressed, the 'Turbo Freeze' mode will start. If the 'Turbo Freeze' button is pressed again during 'Turbo Freeze' mode, the turbo freeze mode will be cancelled. 'TURBO FREEZE' mode activates uninterrupted decrease in temperature; the (-) or (+) keys will not be operational 88 LED will continuously flash 'T.F' during 'Turbo Freeze' mode. The compressor & condenser fan motor will operate for 120 minutes. 																																																																																										

MAIN PCB PROGRAMING

No	Control Function	Control Objects	Description																														
3	Turbo Freeze	Compressor Evap. Fan Motor Cond. Fan Motor 88 LED	<p>6. If the 'Turbo Freeze' button is pressed under defrost mode, 88 LED will flash 'T.F'; however, 'Turbo Freeze' mode will start after defrost mode is terminated.</p> <p>7. If defrost mode occurs during 'Turbo Freeze' mode, the defrost mode will start after the turbo freeze mode is terminated.</p>																														
4	Determination of Defrost		<p>1. Defrost mode will initiate under the following condition:</p> <p>2. Make sure 6 hours have passed since the last defrost mode was terminated.</p> <ul style="list-style-type: none"> - F sensor ERROR - Defrost sensor ERROR - Door sensor ERROR - 14 hours have passed since last defrost mode was terminated. - Doors have been open for more than 10 minutes. - Compressor has been running for more than 85% of the time. <p>3. If defrost mode does not initiate under errors described above, it will also trigger if:</p> <ul style="list-style-type: none"> - Compressor has been operating for more than 6 hours. <p>4. where, the defrost period is 6 hours when the appliance is initially powered up.</p>																														
5	Defrost Function	Heater Compressor Evap. Fan Motor Cond. Fan Motor	<p>1. Defrost Step</p> <table border="1" style="width: 100%; border-collapse: collapse; margin: 10px 0;"> <thead> <tr> <th></th> <th style="text-align: center;">Pre-cool</th> <th style="text-align: center;">Heater</th> <th style="text-align: center;">Pause</th> <th style="text-align: center;">Fan Delay</th> </tr> </thead> <tbody> <tr> <td>Comp</td> <td style="text-align: center;">on</td> <td style="text-align: center;">off</td> <td style="text-align: center;">off</td> <td style="text-align: center;">on</td> </tr> <tr> <td>E-fan motor</td> <td style="text-align: center;">on</td> <td style="text-align: center;">off</td> <td style="text-align: center;">off</td> <td style="text-align: center;">off</td> </tr> <tr> <td>C-fan motor</td> <td style="text-align: center;">on</td> <td style="text-align: center;">off</td> <td style="text-align: center;">off</td> <td style="text-align: center;">on</td> </tr> <tr> <td>Heater</td> <td style="text-align: center;">off</td> <td style="text-align: center;">on</td> <td style="text-align: center;">off</td> <td style="text-align: center;">off</td> </tr> <tr> <td>Max time</td> <td style="text-align: center;">15min</td> <td style="text-align: center;">30min</td> <td style="text-align: center;">5min</td> <td style="text-align: center;">5min</td> </tr> </tbody> </table> <p>A. Pre-cool step</p> <ol style="list-style-type: none"> a. It prevents from excessive high temperature during defrost mode. b. Compressor, condenser fan motor and evaporator fan motor will run continuously during the pre-cool step. c. 88 LED shows the temperature inside the cabinet. d. If F-sensor temperature is lower than -16°F or maximum time of pre-cool step interval for 15 minutes, the pre-cool step will turn off. e. 'Turbo Freeze' mode is enabled just once during pre-cool step. <p>B. Heater defrost step</p> <ol style="list-style-type: none"> a. To minimize the risk of icing up, the defrost heater will run periodically. b. 88 LED display 'dF' when the defrost heater is energized. c. The defrost heater will stop running if the temperature of D-sensor rises above 43°F (6°C) or exceeds a maximum running time, 30 minutes. d. If D-sensor temperature does not reach 43°F in 30 minutes, error code will be recorded on a MICOM. 		Pre-cool	Heater	Pause	Fan Delay	Comp	on	off	off	on	E-fan motor	on	off	off	off	C-fan motor	on	off	off	on	Heater	off	on	off	off	Max time	15min	30min	5min	5min
	Pre-cool	Heater	Pause	Fan Delay																													
Comp	on	off	off	on																													
E-fan motor	on	off	off	off																													
C-fan motor	on	off	off	on																													
Heater	off	on	off	off																													
Max time	15min	30min	5min	5min																													

MAIN PCB PROGRAMING

No	Control Function	Control Objects	Description
5	Defrost Function	Heater Compressor Evap. Fan Motor Cond. Fan Motor	<p>C. Pause step</p> <ol style="list-style-type: none"> a. To ensure that refrigeration system has the time to be stabilized, please allow compressor and fan motors to have enough rest time after heater defrost mode is deactivated. b. Time = 5 min, LED Display panel will be shown as 'dF'. <p>D. Fan delay step</p> <ol style="list-style-type: none"> a. Max. Time = 5 min b. Only Comp. is ON. c. If D-sensor temperature goes down under 14°F in 5 minutes, evaporator fan motor will turn on immediately.
6	Manual Defrost	Heater Compressor Evap. Fan Motor Cond. Fan Motor	<p>A. 1. Press the both (-) and (+) keys for 5 seconds. 88 LED should display "SL". 2. Press the (-) button. 88 LED display "dS". 3. Press the (-) button. 88 LED display "dF" and defrost mode start.</p> <p>B. On manual defrost mode</p> <ol style="list-style-type: none"> 1. The pre-cool step is omitted. 2. Heater defrost step is run. 3. The next procedure is the same as that of defrost mode.
7	Fuzzy Defrost	Heater Compressor Evap. Fan Motor Cond. Fan Motor	<p>The defrost cycle will start during conditions as specified below.</p> <ol style="list-style-type: none"> A. The compressor has run for 30 minutes. B. There is no door open for 30 minutes. C. The temperature of D-sensor is lower than 5°F. D. The temperature of F-sensor is higher than D-sensor's temperature by 32°F for 10 minutes.
8	Comp Restart Prevent	Compressor Cond. Fan Motor	<p>A. Compressor will not run for 5 minutes after off cycle even if F-sensor is in its operatinal range.</p>
9	Power Failure Back up Function	Compressor Evap. Fan Motor Cond. Fan Motor	<p>A. Compressor will not be run for 5 minutes after power failure.</p> <p>B. Only Evap. Fan Motor is ON.</p>
10	Door Open Alarm Function	Buzzer 88 LED	<p>A. The LED Display panel will read 'DOOR' icon and will not flash 'FAN' icon.</p> <p>B. Before sounding the beeper:</p> <ol style="list-style-type: none"> 1. Door was open for more than 30 seconds, the buzzer will sound 3 times. 2. Door was open for more than 60 seconds, the buzzer will sound 5 times. 3. Door was open for more than 5 minutes, the buzzer will continuously sound.
11	Buzzer Function	Buzzer	<p>A. Beep sound rings once after initial power up.</p> <p>B. Beep sound rings whenever each button is pressed.</p> <p>C. If the door stays open past a certain amount of time, beeping will occur. (see door open alarm function)</p>

5-3. FUNCTION MODE

5-3-1) Enter the Function mode

- ▶ Press the both up/down (or +/-) buttons at the same time for 5 seconds.
88 LED displays "SL".

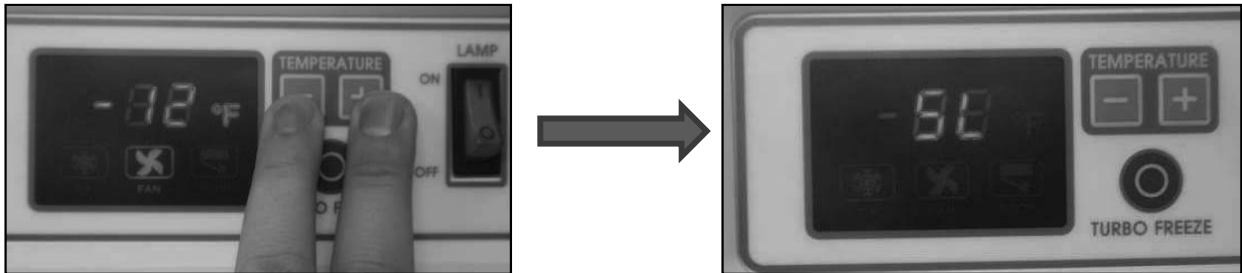

5-3-2) Manual Defrost Mode

- ▶ initiate the manual defrost function by pressing the down (-) button once while displaying SL on the display. Then, the display will show 'dS'.
- ▶ if the down (-) button is pressed again while displaying 'dS', it will display 'dF' and it is in manual defrost mode.
- ▶ Repeat the procedure to terminate the manual defrost.

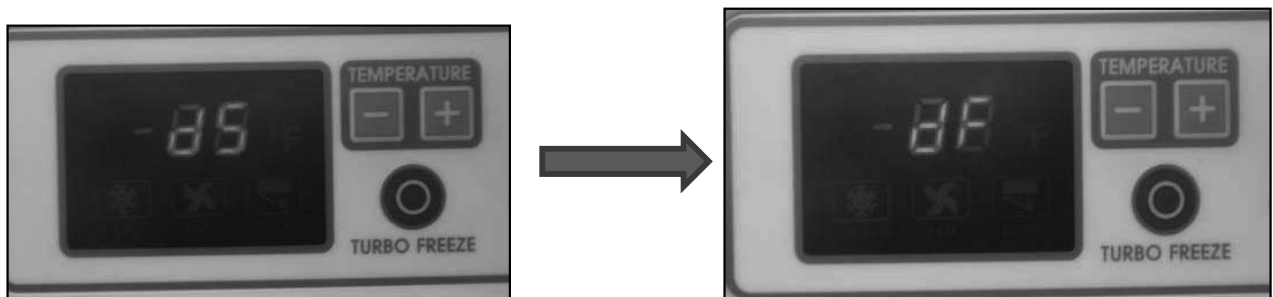

5-3-3) Error display Mode

- ▶ Press the down (-) button 4 times while displaying 'SL' on the display.
If there is no error in the memory, display will show 'no'.

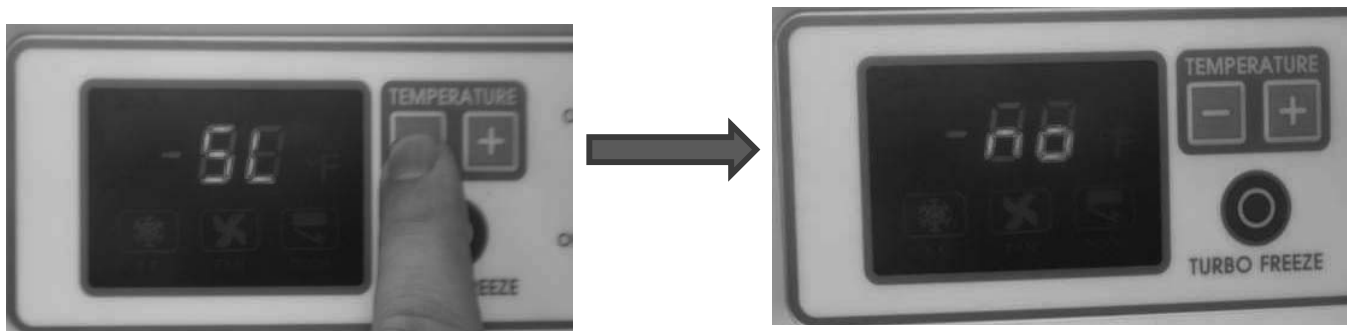

MAIN PCB PROGRAMING

Code	Content	Perception Method	Freezer Operation State
F1	F-sensor Malfunction	- . Sensor shorted.	- . The compressor runs for 30 minutes and stops for 5 minutes repeatedly.
F0		- . Sensor disconnected.	
D1	D-sensor Malfunction	- . Sensor shorted	- . Defrost heater may operate it. - . If F-sensor temperature is higher than 28.4°F, the heater goes off.
D0		- . Sensor disconnected	- . Defrost heater turns on for 20 minutes if F-sensor is in error mode too.
C1	Cycle, Comp. Malfunction	- . The temperature of D-sensor is over 32°F even though the compressor has been running for 30 minutes.	- . Normal operation (Compressor is automatically turned on and off by F-sensor.)
F3	Defrost Malfunction	- . The temperature of D-sensor doesn't reach 43°F within 30 minutes.	- . Defrost heater will be on for 30 minutes. - . If the D-sensor's temp. reaches 43°F within 30 minutes, defrost heater will be turned off immediately.

6. PARTS LIST

6-1. TGM-5SD*, TGM-7SD* TGF-5SD*

Part Name	Part Number	Description	Model		
			TGM	TGM	TGF
			5SD	7SD	5SD
COMPRESSOR	30200N4400	AEZ2415Z(115V/60HZ)			1
COMPRESSOR	P0189A0100	MSA151D-L1B, 115~127V/60Hz	1	1	
CONDENSER FAN MOTOR	3963220410	IS-4420DWSG-1 (TURBO)			1
CONDENSER FAN MOTOR	P0191A0200	DAI-6202DWSUA	1	1	
CONDENSER COOLING FAN	30218F0200	AL Φ175			1
CONDENSER COOLING FAN	4034L38038	72G33L	1	1	
CONDENSER COIL	P0156A0100	CU			1
CONDENSER COIL	P0156A0110	CU	1	1	
DRYER	3020005501	FS-480T			1
DRYER	3016800103	FRB-15CP-42CH, 400B	1	1	
DEFROST TIMER	30281M0300	CZ-2001-56 (110V)			1
SMPS	30284R0500	LPV-20-12	1	1	1
EVAPORATOR COIL	P0170A0300	CU			1
EVAPORATOR COIL	P0170A0310	CU	1	1	
DEFROST HEATER	P0128A0100	200W			1
BI-METAL	3018121300	PST-3A (9±3°C)			1
THERMAL FUSE	30272L0401	PST3-DW008 (80±5°C)			1
EVAPORATOR FAN MOTOR	P0191A0100	DAI-6202DWSUA-1	1	1	1
EVAPORATOR COOLING FAN	30218F0110	Φ150, 6 BLADES	1	1	1
DRAIN HOSE HEATER	30228L1380	115V-10W			1
DRAIN PAN HEATER	P0128A0200	115V-50W			1
FAN COVER(SHROUD)	P0114A6600	ABS SG0760 W95439	1	1	1
LED LAMP	P0136A0100	10W, HORIZONTAL TYPE	1	1	1
THERMOSTAT	30283M0700	GNA(F)-106D-06A			1
THERMOSTAT	30283F1000	GNA-242L	1		
THERMOSTAT	30283F0800	GNA-240L-4		1	
DOOR ASSEMBLY	P0100A1400	DOOR GLASS, GASKET AND HANDLE INCLUDED, COLOR OPTION REQUIRED			1
DOOR ASSEMBLY	P0100A1500	DOOR GLASS, GASKET AND HANDLE INCLUDED, COLOR OPTION REQUIRED	1		
DOOR ASSEMBLY	P0100A1600	DOOR GLASS, GASKET AND HANDLE INCLUDED, COLOR OPTION REQUIRED		1	
BOTTOM DOOR HINGE	P0129A0300		1	1	
BOTTOM DOOR HINGE	P0129A0310				1
TOP DOOR HINGE	P0129A0100		1	1	1
DOOR SWITCH	P0181L0200	DSD-6 (PUSH TYPE)	1	1	1
FAN CONTROL PCB	P0143A0100		1	1	
REAR COVER(DISCHARGE PORTS)	P0114A6800		1	1	1
REAR COVER(DISCHARGE PORTS)	P0114A680P		1	1	1
SHELF(A)	P0178A0200	BOTTOM SHELF, PE COATING	1	1	1
SHELF(B)	P0178A0300	TOP OR MIDDLE SHELF, PE COATING	1	2	1
SHELF FIXTURE	30220L0900	PA6	10	14	10
DRAIN PAN	30211B0100	HIPS T2.0	1	1	1

PARTS LIST

6-2. TGM-10SD*, TGM-12SD* TGF-10SD*

Part Name	Part Number	Description	Model		
			TGM	TGM	TGF
			10SD	12SD	10SD
COMPRESSOR	30200R1100	CAE2420Z(TECUMSEH,115V/60HZ)			1
COMPRESSOR	30289R0100	MK183D-L2UB	1	1	
CONDENSER FAN MOTOR	P0191Q0200	DAI-8204DWSUA	1	1	1
CONDENSER COOLING FAN	30218B0300	Φ200, 5익, AL:흡입	1	1	1
SOLENOID VALVE	30254Q0150	321RBS3VTRF-I-1K-8P			1
CONDENSER COIL	P0156A0200	CU			1
CONDENSER COIL	P0156A0210	CU	1	1	
DRYER	30268Q0300	C-052-S(CATCH-AII)	1	1	1
SPEAKER	P0157C0100	40F05 8Ω MAX 5W	1	1	1
MAIN PCB(F)	30243R0700	GFF1151(FOR FREEZER)			1
MAIN PCB(R)	30243R0600	GRF1151(FOR REFRIGERATOR)	1	1	
SMPS(통합 BOARD)	30284R1100	40W	1	1	1
POWER RELAY	30281H0350	GMC-30P2, 110(LS)	1	1	1
DISPLAY PCB	30242R0100		1	1	1
EVAPORATOR COIL	P0170A0400	CU			1
EVAPORATOR COIL	P0170A0410	CU	1	1	
DEFROST HEATER	P0128U0200	200W			1
R/D-SENSOR	30227Q1310	NBC-KD43-RDI	1	1	
F/D-SENSOR	30227Q1210	DTA-KD38-FDI			1
THERMAL FUSE	30272L0401	PST3-DW008 (80±5°C)			1
EVAPORATOR FAN MOTOR	P0191A0100	DAI-6202DWSUA-1	1	1	1
EVAPORATOR COOLING FAN	30218F0110	Φ150, 6 BLADES	1	1	1
DRAIN HOSE HEATER	30228L1380	115V-10W			1
DRAIN PAN HEATER	P0128A0200	115V-50W			1
FAN COVER(SHROUD)	P0114A6600	ABS SG0760 W95439	1	1	1
LED LAMP	P0136A0110	14W, HORIZONTAL TYPE	1	1	1
DOOR ASSEMBLY	P0100A1700	DOOR GLASS, GASKET AND HANDLE INCLUDED, COLOR OPTION REQUIRED			1
DOOR ASSEMBLY	P0100A1800	DOOR GLASS, GASKET AND HANDLE INCLUDED, COLOR OPTION REQUIRED	1		
DOOR ASSEMBLY	P0100A1900	DOOR GLASS, GASKET AND HANDLE INCLUDED, COLOR OPTION REQUIRED		1	
BOTTOM DOOR HINGE	P0129R0200		1	1	1
TOP DOOR HINGE	P0129A0100		1	1	1
DOOR SWITCH	P0181L0200	DSD-6 (PUSH TYPE)	1	1	1
BOTTOM GRILLE ASSEMBLY	P0100A2000	COLOR OPTION REQUIRED	1	1	1
SHELF	P0178A0600	PE COATING	3	3	3
SHELF FIXTURE	30220L0900	PA6	14	14	14
DRAIN PAN	3021100002	HIPS	1	1	1

PARTS LIST

6-3. TGM-15SD*, TGF-15SD*, TGM-20SD*, TGM-23SD* TGF-23SD*

Part name	Part Number	Description	Model				
			TGM	TGF	TGM	TGM	TGF
			15SD	15SD	20SD	23SD	23SD
ADJUSTABLE FEET BOLT							
ADJUSTABLE FEET BOLT	30206K0100	1/2" 28mm	4	4	4	4	4
Compressor							
Compressor	30289R0100	MK183D-L2UB(115V/60Hz)	1		1	1	
Compressor	30200R1100	CAE2420Z(115V/60Hz)		1			
Compressor	30200R1000	CAJ2432Z(115V/60Hz)					1
Compressor Relay	-	6R8MD2	1		1	1	
Compressor Overload	-	4TM 445PHBZZ-53	1		1	1	
Compressor Run Capacitor	30289R0110	250V/12 μ F	1		1	1	
Power Relay	30281H0350	GMC-30P2 (110V)	1	1	1	1	1
Main Power Cord	30213A1014	KKP-30B(단자)	1	1	1	1	1
Condenser							
Condenser Coil	P0156U0100	CU+AL	1				
Condenser Coil	P0156U0200	CU+AL		1			
Condenser Coil	30200L4002	CU+AL			1	1	
Condenser Coil	30200M7400	CU+AL					1
Condenser Fan Motor	P0191Q0200	DAI-8204DWSUA	1	1	1	1	1
Condenser Fan Motor Blade	30218B0300	AL 4 (Φ200mm)	1	1			
Condenser Fan Motor Blade	30218A0300	AL 4 (Φ250mm)			1	1	1
Dryer	30268F1000	30g	1				
Dryer	30268Q0300	C-052-S		1	1	1	1

PARTS LIST

Part name	Part Number	Description	Model					
			TGM	TGF	TGM	TGM	TGF	
			15SD	15SD	20SD	23SD	23SD	
Evaporator								
Evaporator Coil	P0170U0100	Cu + AL	1					
Evaporator Coil	P0170U0200	Cu + AL		1				
Evaporator Coil	30270L0120	AL			1	1		
Evaporator Coil	30270R0108	Cu + AL					1	
Evaporator Sensor	30227Q1310	R-D Sensor	1		1	1		
Evaporator Sensor	30227Q1210	F-D Sensor		1			1	
Evaporator Thermal Fuse	30272L0401	PST-3(80°C/10°C)		1			1	
Evaporator Defrost Heater	P0128U0200	200W(Sheath Heater)		1				
Evaporator Defrost Heater	30228L0803	445W(Sheath Heater)					1	
Evaporator Drain Pan Heater	P0128A0200	50W		1				
Evaporator Drain Pan Heater	30228L1400	90W					1	
Evaporator Drain Hose Heater	30228L1380	10W		1			1	
Evaporator Fan Motor Guard	30214K0100	HIPS	1			1	1	
Evaporator Fan Motor Blade	30218U0100	AL Φ175	1	1	1	1	1	
Evaporator Fan Motor	P0191Q0100	DAI-8154DWSUA	1	1	1	1	1	
Door								
Door Assembly	P0100U2000	WHITE COLOR	1					
	P0100U2010	BLACK COLOR						
	P0100U2020	VIOLET COLOR						
Door Assembly	P0100U2100	WHITE COLOR		1				
	P0100U2110	BLACK COLOR						
	P0100U2120	VIOLET COLOR						
Door Assembly	P0100C0300	WHITE COLOR			1	1		
	P0100C0310	BLACK COLOR						
	P0100C0320	VIOLET COLOR						
Door Assembly	P0100C0400	WHITE COLOR					1	
	P0100C0410	BLACK COLOR						
	P0100C0410	VIOLET COLOR						
Door Gasket	P0123A0800	638×1402	1	1				
Door Gasket	P0123A0700	653*1352			1	1	1	
Door Handle	P0126A0100	AL	1	1	1	1	1	

PARTS LIST

Part name	Part Number	Description	Model				
			TGM	TGF	TGM	TGM	TGF
			15SD	15SD	20SD	23SD	23SD
PCB & SMPS							
Main PCB	30243R0600	GRF1151	1		1	1	
Main PCB	30243R0700	GFF1151		1			1
Display PCB	30242R0200	TURBO COOLING	1		1	1	
Display PCB	30242R0100	TURBO FREEZE		1			1
SMPS	30284R1100	SM40W115	1	1	1	1	1
LED							
LED	30236R2200	LED LAMP 19W	1	1	1	1	1
SWITCH							
Power Switch	30281Q0101	R19A(RA15)	1	1	1	1	1
Lamp Switch	30281Q0101	R19A(RA15)	2	2	2	2	2
Door Switch	30281R0101	E31001CA	1	1	1	1	1
Sign Panel							
Light Guide Panel	P0142U4000	8.28W-12V	1	1			
Light Guide Panel	P0142U4100	8.64W-12V			1	1	1
Sign Panel	P0145A0610	COLD DRINKS	1				
Sign Panel	P0145A0600	FROZEON FOODS		1			
Sign Panel	P0145A0810	COLD DRINKS			1	1	
Sign Panel	P0145A0800	FROZEON FOODS					1
Speaker	P0175C0100	40F05 8Ω MAX 5W	1	1	1	1	1

PARTS LIST

Part name	Part Number	Description	Model				
			TGM	TGF	TGM	TGM	TGF
			15SD	15SD	20SD	23SD	23SD
SHELF							
Shelf	P0178U0200		4	4			
Shelf	P0178H0100				4		
Shelf	30278R0102					4	4
Shelf(Back)	P0150U0100			1			
Shelf(Back)	30250R0400						1
Shelf(under)	30278R0500						
Shelf(Front)	30278R0400						
Shelf	30278R0600						
Shelf(Back)	30278R0700						
Solenoid Valve							
Solenoid Valve	30254Q0150	321RBS3VTRF		1			1

PARTS LIST

6-4. TGM-35SD*, TGM-47SD*, TGM-72SD*

TGF-35SD*, TGF-47SD*, TGF-72SD*

Part name	Part Number	Description	Model					
			TGM 35SD	TGM 47SD	TGM 72SD	TGF 35SD	TGF 47SD	TGF 72SD
ADJUSTABLE FEET BOLT								
ADJUSTABLE FEET BOLT	30260K0100	1/2" 28mm	5	5	6	5	5	6
Compressor								
Compressor	30200Q1200	SK1A1C-L2W(115V/60Hz)	1	1				
Compressor	3020014570	T6217Z(115V/60Hz)			1			
Compressor	30200Q3600	CAJ2446Z(220V/60Hz)					1	1
Compressor	P0189A0200	NJ2192GK(115V/60Hz)				1		
Power Relay	30281H0350	GMC-30P2 (110V)	1	1	1	1	1	2
Main Power Cord	30213A1014	KKP-30B(단자)	1	1	1			
Main Power Cord	30227R6100	4 Wire					1	1
Main Power Cord	P0113A0200	TURBO CHINA 수입				1		
Power Plug	30213Q0500	HUBELL					1	1
Condenser								
Condenser Coil	30200L4202	CU+AL	1	1				
Condenser Coil	30200K3002	CU+AL			1			
Condenser Coil	30200Q3500	CU+AL				1	1	
Condenser Coil	30200A2222	CU+AL						2
Condenser Fan Motor	P0191Q0200	DAI-8204DWSUA	1	1	1	2		
Condenser Fan Motor	3963336200	DAI-8204DWSQ-1					2	2
Condenser Fan Motor Blade	30218B0200	AL 4 (Φ225mm)	1			2	2	
Condenser Fan Motor Blade	30218A0300	AL 4 (Φ250mm)		1	1			2
Dryer	30268Q0300	C-052-S	1	1	1	1	1	1
SHELF								
Shelf(Left))	P0178F0100		4			4		
Shelf(Right)	P0178F0110		4			4		
Shelf(Back)	P0150F0100					2		
Shelf(Left))	P0178Q0100			4			4	
Shelf(Right)	P0178Q0110			4			4	
Shelf(Back)	P0150Q0100						2	
Shelf(Left))	P0178K0100				4			4
Shelf(Middle)	P0178K0300				4			4
Shelf(Right)	P0178K0200				4			4
Shelf(Back)	P0150U0100							3

PARTS LIST

Part name	Part Number	Description	Model					
			TGM	TGM	TGM	TGF	TGF	TGF
			35SD	47SD	72SD	35SD	47SD	72SD
Evaporator								
Evaporator Coil	30270L0220		1					
Evaporator Coil	30270L0606					1		
Evaporator Coil	30270L0213			1				
Evaporator Coil	30270Q0110				1			
Evaporator Coil	30270R0200						1	2
Evaporator Sensor	30227Q1310	R-D Sensor	1	1	1			
Evaporator Sensor	30227Q1210	F-D Sensor				1	1	1
Evaporator Sensor	30227Q1220	D Sensor						1
Evaporator Thermal Fuse	30272L0401	PST-3(80°C/10°C)				1	1	2
Evaporator Defrost Heater	30228L0701	600W(Sheath Heater)				1	1	2
Evaporator Drain Pan Heater	30228L1500	90W				1	1	2
Evaporator Drain Hose Heater	30228L1380	10W				1	1	2
Evaporator Fan Motor Guard	30214K0100	HIPS		2	2		2	
Evaporator Fan Motor Guard	30214P2500	HIPS	1			1		2
Evaporator Fan Motor Blade	30218U0100	AL 5 Φ175		2	2		2	
Evaporator Fan Motor Blade	30218B0300	AL 4 (Φ200mm)	1			1		2
Evaporator Fan Motor	P0191Q0100	DAI-8154DWSUA	1	2	2	1	2	2
PCB & SMPS & TRANSFORMER								
Main PCB	30243R0600	GRF1151	1	1	1			
Main PCB	30243R0700	GFF1151				1	1	
Main PCB	P0143K0100	2GFF1151						1
Display PCB	30242R0200	TURBO COOLING	1	1	1			
Display PCB	30242R0100	TURBO FREEZE				1	1	1
SMPS	30284R1100	SM40W115	1	1	1	1	1	1
LED & SMPS								
LED	30236R2200	LED LAMP 19W	2	2	2	2	2	4
SMPS	30284R0700	LPV-60-12	1	1	1	1	1	2
SWITCH								
Power Switch	30281Q0101	R19A(RA15)	1	1	1	1	1	1
Lamp Switch	30281Q0101	R19A(RA15)	2	2	2	2	2	2
Door Switch	30281R0101	E31001CA	2	2	2	2	2	3

PARTS LIST

Part name	Part Number	Description	Model									
			TGM 35SD	TGM 47SD	TGM 72SD	TGF 35SD	TGF 47SD	TGF 72SD				
Door												
Door Assembly	P0100F0200	WHITE COLOR(LEFT)	1									
	P0100F0210	BLACK COLOR(LEFT)										
	P0100F0220	VIOLET COLOR(LEFT)										
Door Assembly	P0100F0300	WHITE COLOR(RIGHT)	1									
	P0100F0310	BLACK COLOR(RIGHT)										
	P0100F0320	VIOLET COLOR(RIGHT)										
Door Assembly	P0100F0400	WHITE COLOR(LEFT)					1					
	P0100F0410	BLACK COLOR(LEFT)										
	P0100F0420	VIOLET COLOR(LEFT)										
Door Assembly	P0100F0500	WHITE COLOR(RIGHT)					1					
	P0100F0510	BLACK COLOR(RIGHT)										
	P0100F0520	VIOLET COLOR(RIGHT)										
Door Assembly	P0100Q8100	WHITE COLOR(LEFT)	1									
	P0100Q8110	BLACK COLOR(LEFT)										
	P0100Q8120	VIOLET COLOR(LEFT)										
Door Assembly	P0100Q8200	WHITE COLOR(RIGHT)	1									
	P0100Q8210	BLACK COLOR(RIGHT)										
	P0100Q8220	VIOLET COLOR(RIGHT)										
Door Assembly	P0100Q8400	WHITE COLOR(LEFT)						1				
	P0100Q8410	BLACK COLOR(LEFT)										
	P0100Q8420	VIOLET COLOR(LEFT)										
Door Assembly	P0100Q8500	WHITE COLOR(RIGHT)						1				
	P0100Q8510	BLACK COLOR(RIGHT)										
	P0100Q8520	VIOLET COLOR(RIGHT)										
Door Assembly	P0100K0100	WHITE COLOR(LEFT)					1					
	P0100K0110	BLACK COLOR(LEFT)										
	P0100K0120	VIOLET COLOR(LEFT)										
Door Assembly	P0100K0200	WHITE COLOR(MIDDLE)					1					
	P0100K0210	BLACK COLOR(MIDDLE)										
	P0100K0220	VIOLET COLOR(MIDDLE)										
Door Assembly	P0100K0300	WHITE COLOR(RIGHT)					1					
	P0100K0310	BLACK COLOR(RIGHT)										
	P0100K0320	VIOLET COLOR(RIGHT)										
Door Assembly	P0100K0400	WHITE COLOR(LEFT)						1				
	P0100K0410	BLACK COLOR(LEFT)										
	P0100K0420	VIOLET COLOR(LEFT)										
Door Assembly	P0100K0500	WHITE COLOR(MIDDLE)						1				
	P0100K0510	BLACK COLOR(MIDDLE)										
	P0100K0520	VIOLET COLOR(MIDDLE)										
Door Assembly	P0100K0600	WHITE COLOR(RIGHT)						1				
	P0100K0610	BLACK COLOR(RIGHT)										
	P0100K0620	VIOLET COLOR(RIGHT)										
Door Gasket	P0123A0900	462.5*1373	2				2					
Door Gasket	P0123A1100	610*1373		2				2				
Door Gasket	P0123A1200	618*1373			3						3	
Door Handle	P0126A0100	AL	2	2	3		2	2			3	

PARTS LIST

Part name	Part Number	Description	Model					
			TGM 35SD	TGM 47SD	TGM 72SD	TGF 35SD	TGF 47SD	TGF 72SD
Sign Panel								
Light Guide Panel	P0142U4200		1			1		
Light Guide Panel	P0142U4300	16.44W-12V		1			1	
Light Guide Panel	P0142U4400	25.68W-12V			1			1
Sign Panel	P0145A0901	FROZEN FOODS				1		
Sign Panel	P0145A0911	COLD DRINKS	1					
Sign Panel	P0145A1010	COLD DRINKS		1				
Sign Panel	P0145A1000	FROZEN FOODS			1		1	
Sign Panel	P0145A1110	COLD DRINKS					1	
Sign Panel	P0145A1100	FROZEN FOODS						1
Speaker	P0175C0100	40F05 8Ω MAX 5W	1	1	1	1	1	1
Solenoid Valve								
Solenoid Valve	30254Q0150	321RBS3VTRF				1	1	2

7. REPLACEMENT OF MAIN COMPONENTS

7-1. TGM-5SD*, TGM-7SD*, TGF-5SD*

7-1-1. BACK COVER PARTS

- COMPRESSOR, CONDENSER, CONDENSER FAN MOTOR. SMPS
- DEFROST TIMER(FREEZER)

A. Remove the six screws, and pull out the Back Cover.

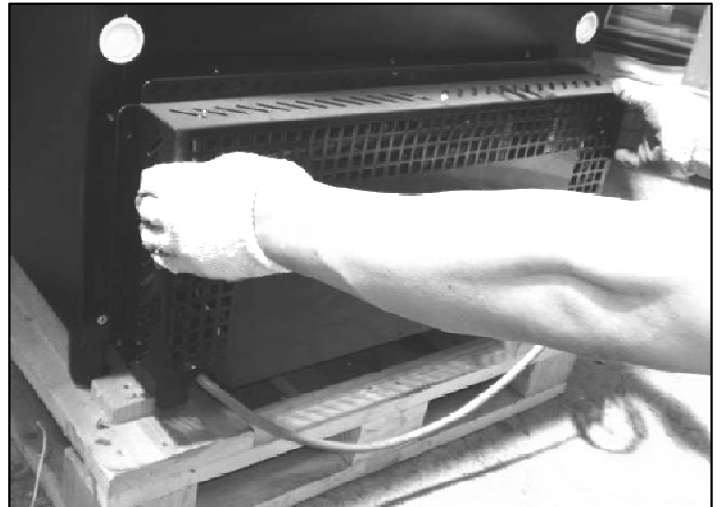
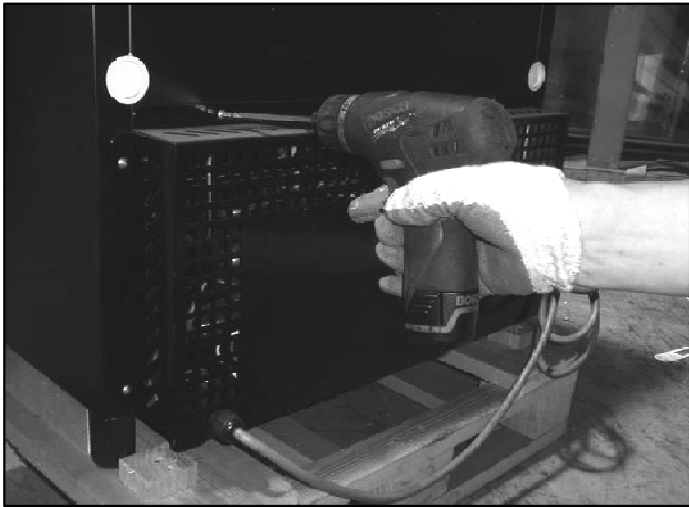

B. Remove the six screws and Replace the Main Components.

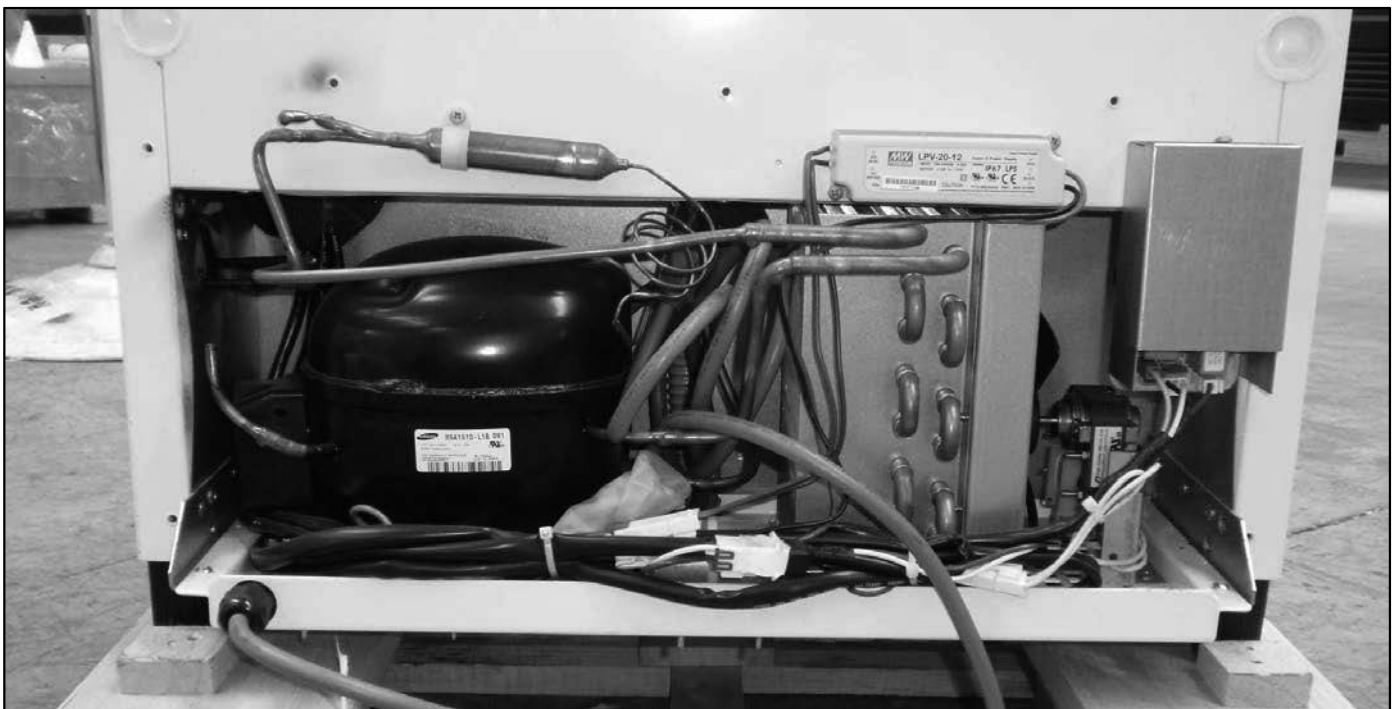

REPLACEMENT OF MAIN COMPONENTS

7-1-2. DOOR PARTS

A . Remove the Four screws on the top hinge.



B . Disconnect the two wires and Remove the four screws on the bottom hinge.

=> There is no wire heater in the Refrigerator(TGM-5SD*, TGM-7SD*)

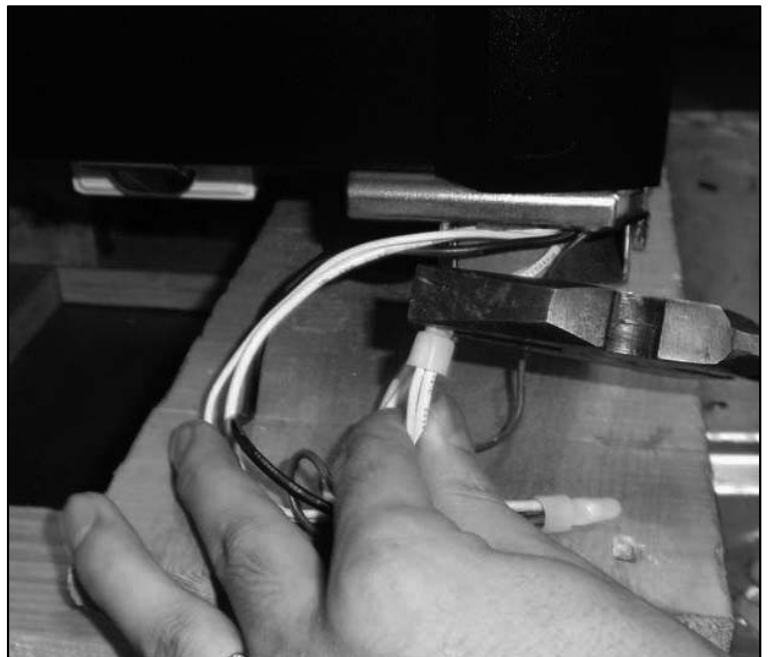

C . Replace the Door ASSY.

REPLACEMENT OF MAIN COMPONENTS

7-1-3. REFRIGERATION COMPARTMENT PARTS.

A . Remove the eight screws and pull out the Evaporator Front Cover.

- Replace the thermostat and LED.



B. Pull out and Remove the shelves.



C. Remove the screws on the shelf standards.



REPLACEMENT OF MAIN COMPONENTS

D . Remove the screws and pull out the back cover.



D . Remove the screws and pull out the Evaporator bottom cover.



E . Replace the main components.

● **TGM-5SD*, TGM-7SD***

- Replace the Evaporator and Evaporator fan motor.

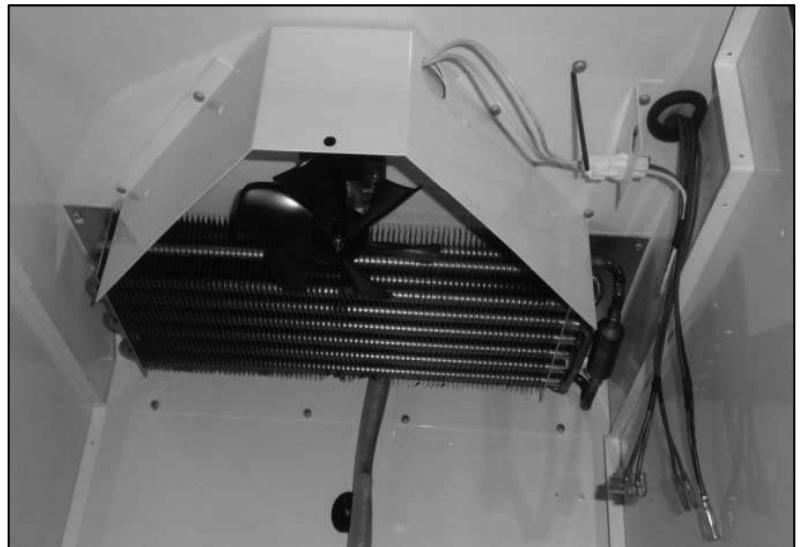

● **TGF-5SD***

- Replace the Evaporator and Evaporator fan motor and Defrost Heater.



REPLACEMENT OF MAIN COMPONENTS

7-1-4. DOOR SWITCH.

A . Remove the four screws and pull out the Door Switch Assy.



B. Replace the Door Switch.

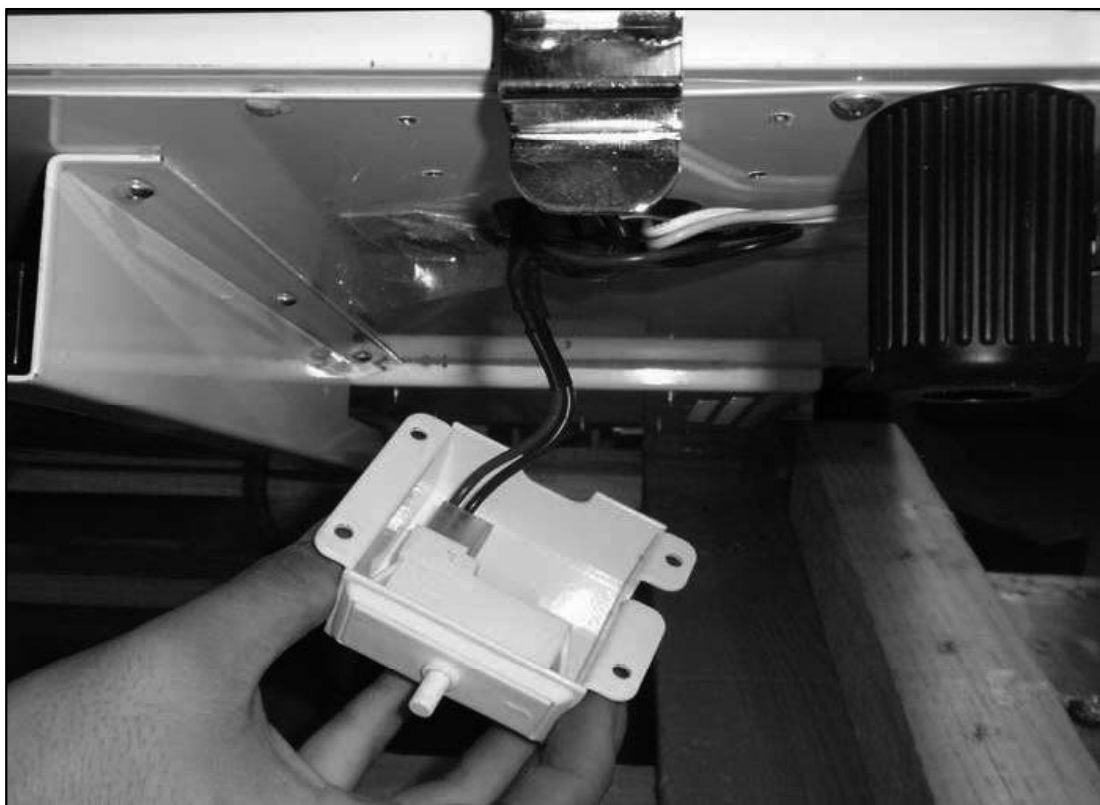

REPLACEMENT OF MAIN COMPONENTS

7-2. TGM-10SD*, TGM-12SD*, TGF-10SD*

7-2-1. BOTTOM GRILLE PARTS

- MAIN PCB, SMPS, POWER RELAY
- DISPLAY PCB, LAMP SWITCH, POWER SWITCH
- COMPRESSOR, CONDENSER, CONDENSER FAN MOTOR.

A. Lift and pull out the Bottom Grill.



B. Remove the two screws and Replace the Display PCB and Switch.

(Power Switch, Lamp Switch)



REPLACEMENT OF MAIN COMPONENTS

C . Remove the Electrical Box Cover.

- . Remove the four screws and pull out the Back Grill Assy.

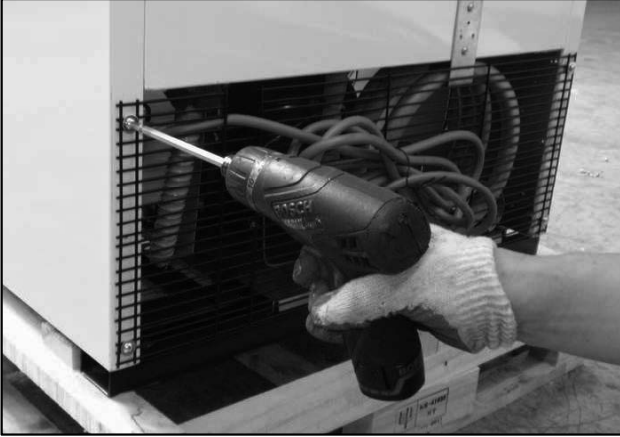

- . Remove the four screws and pull out the Back Grill Assy.

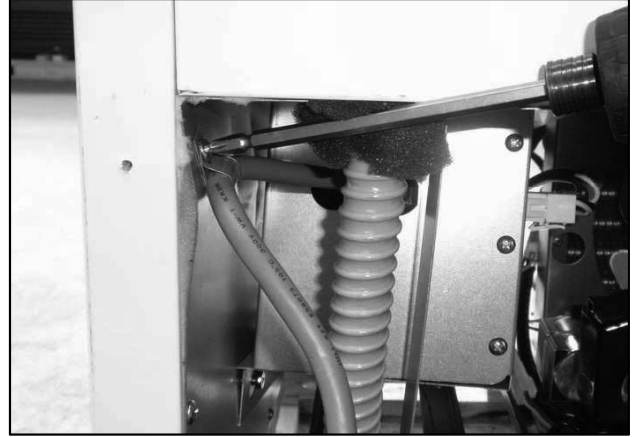

- . Remove the two screws and pull out the Switch Box ASSY.



- . Replace the Main PCB & SMPS & Power Relay

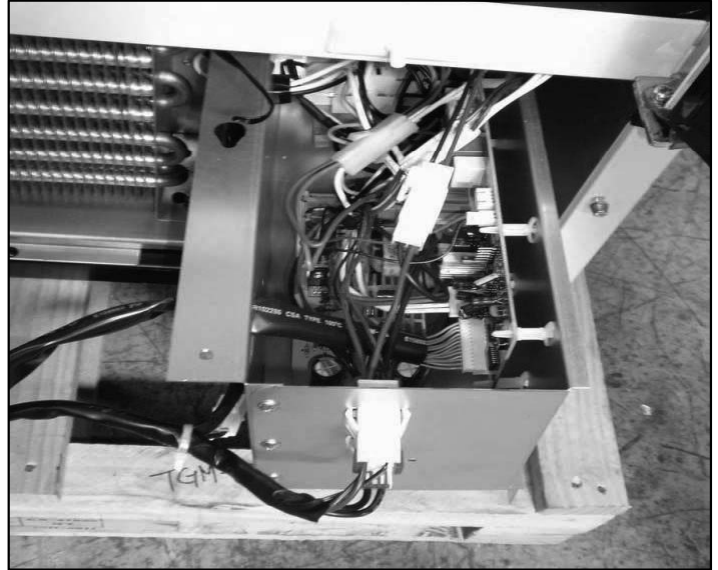

d . Replace the speaker.

- Speaker is on the left side wall.



REPLACEMENT OF MAIN COMPONENTS

E . Replace the Condensing Unit

- . Remove the two screws and pull out the Condensing Unit.

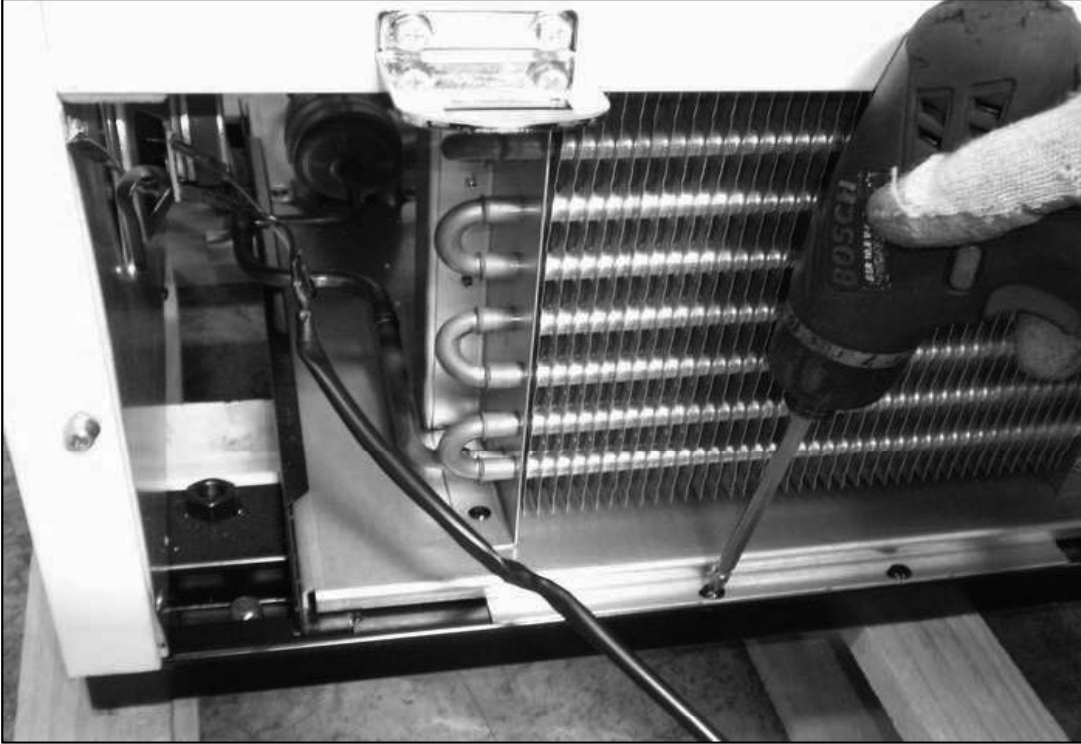

- . Replace the Compressor & Condenser & Condenser Fan Motor.



REPLACEMENT OF MAIN COMPONENTS

7-2-2. DOOR PARTS

A . Remove the Four screws on the top hinge.



B . Disconnect the two wires and Remove the four screws on the bottom hinge.

=> There is no wire heater in the Refrigerator(TGM-5SD*, TGM-7SD*)

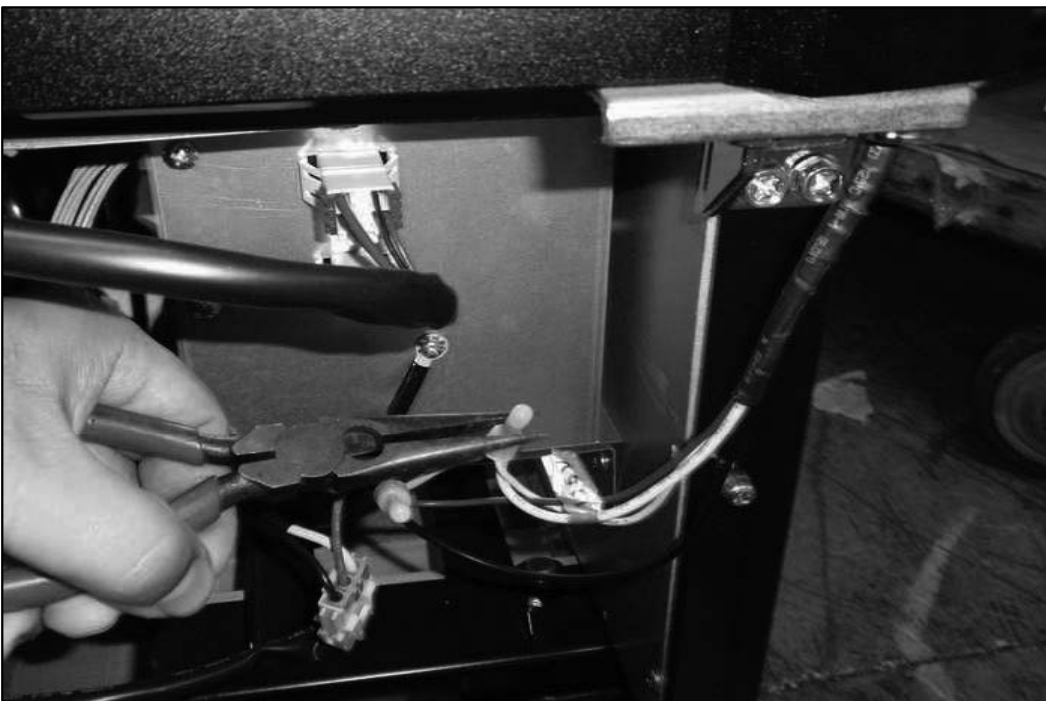

C . Replace the Door ASSY.

REPLACEMENT OF MAIN COMPONENTS

7-2-3. REFRIGERATION COMPARTMENT PARTS.

A . Remove the eight screws and pull out the Evaporator Front Cover.

- Replace the LED.

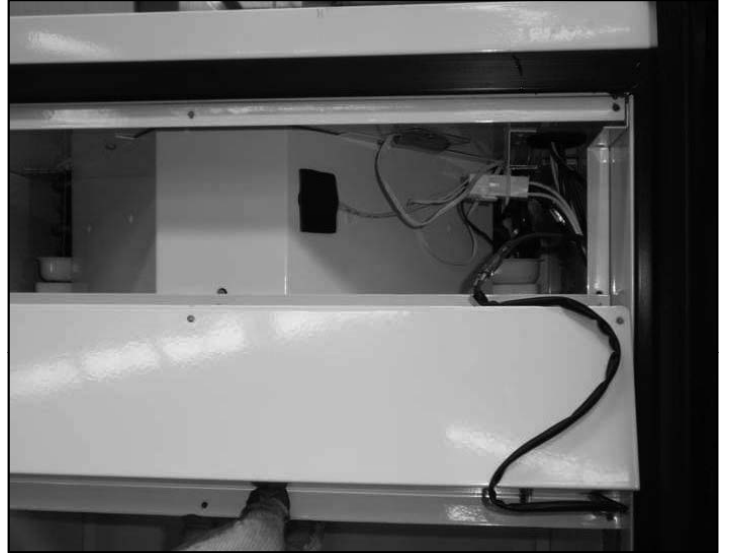

B. Pull out and Remove the shelves.



C. Remove the screws on the shelf standards.



REPLACEMENT OF MAIN COMPONENTS

D . Remove the screws and pull out the back cover.



D . Remove the screws and pull out the Evaporator bottom cover.



E . Replace the min components.

● **TGM-10SD*, TGM-12SD***

- Replace the Evaporator and Evaporator fan motor and Sensors.

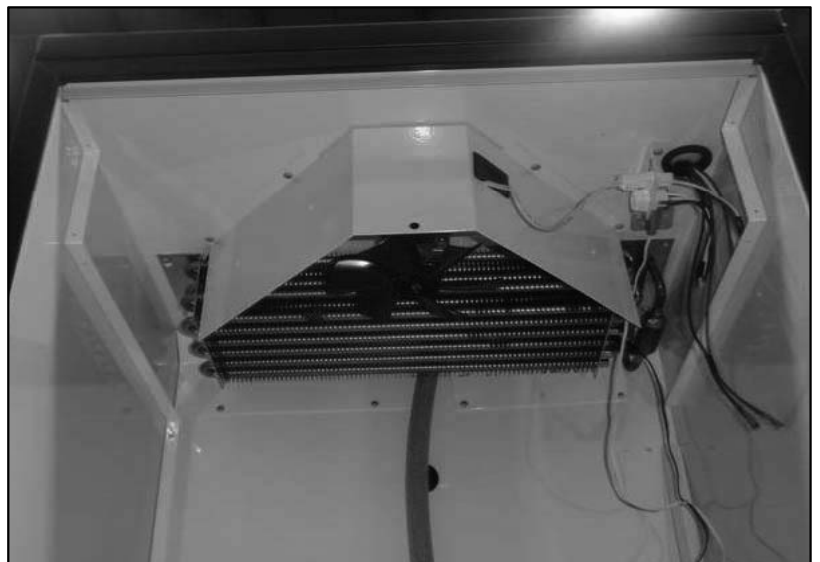

● **TGF-10SD***

- Replace the Evaporator and Evaporator fan motor and Defrost Heater and sensors.

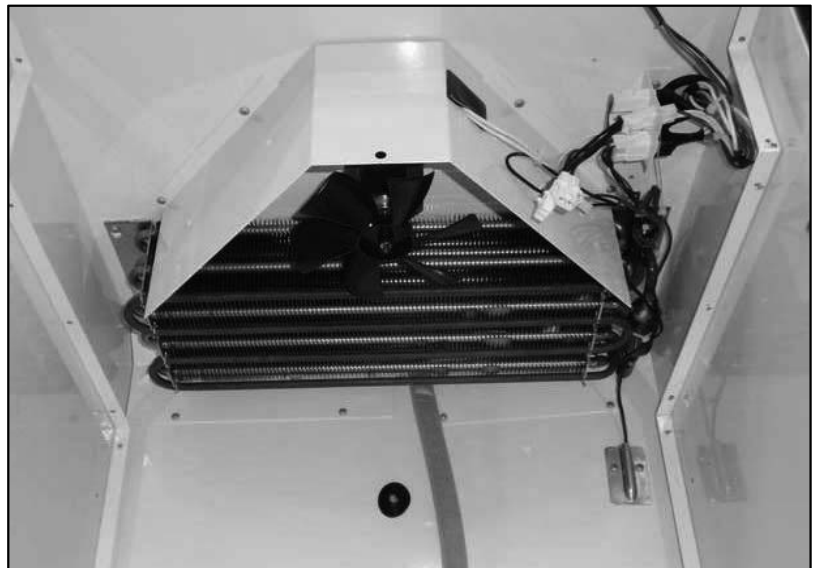

REPLACEMENT OF MAIN COMPONENTS

7-2-4. DOOR SWITCH.

A . Pull out the Door Switch.



B. Replace the Door Switch.

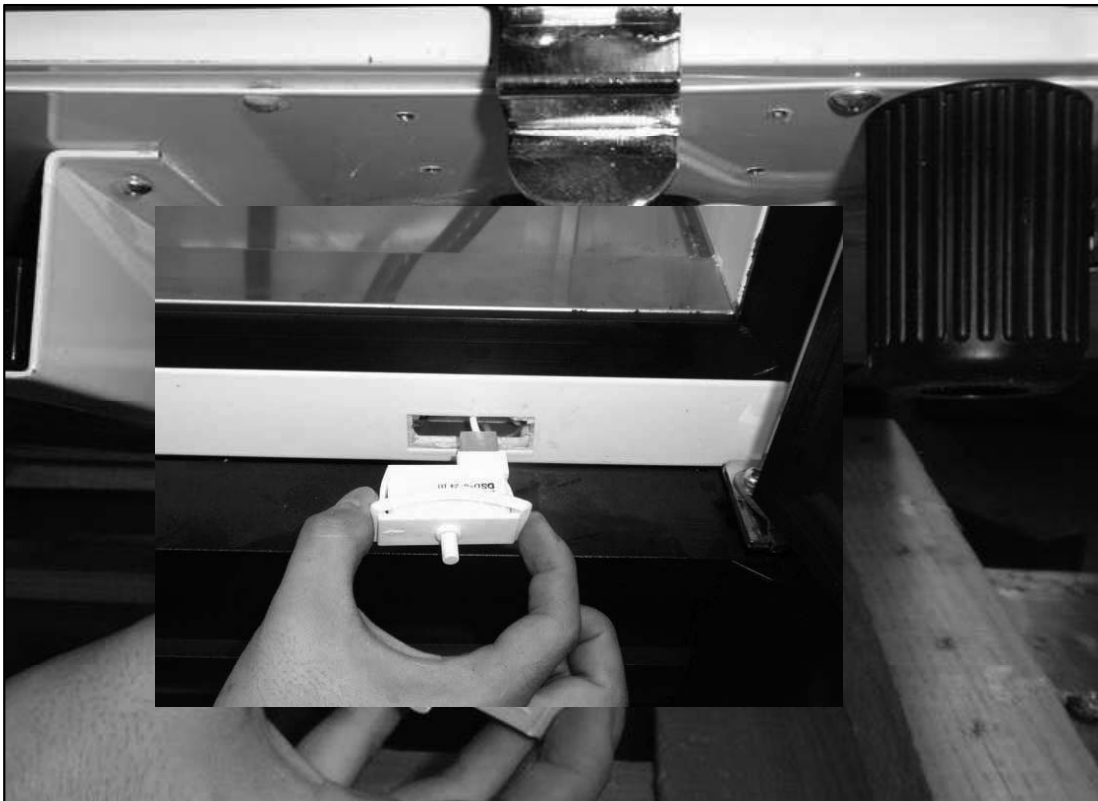

REPLACEMENT OF MAIN COMPONENTS

7-3. TGM-15SD*, TGM-20SD*, TGM-23SD*, TGF-15SD*, TGF-23SD*

7-3-1. BOTTOM GRILLE PARTS

- MAIN PCB, SMPS, POWER RELAY
- DISPLAY PCB, LAMP SWITCH, POWER SWITCH
- COMPRESSOR, CONDENSER, CONDENSER FAN MOTOR.

A. Lift and pull out the Bottom Grill

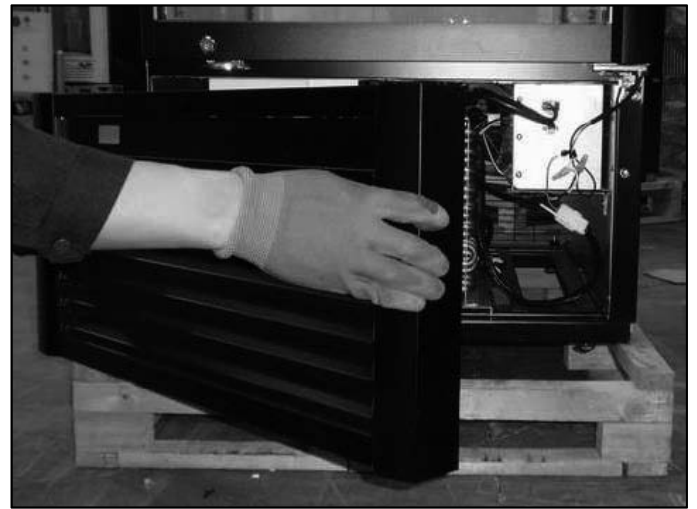

B. Remove the two screws and Replace the Display PCB and Switch. (Power Switch, Lamp Switch)

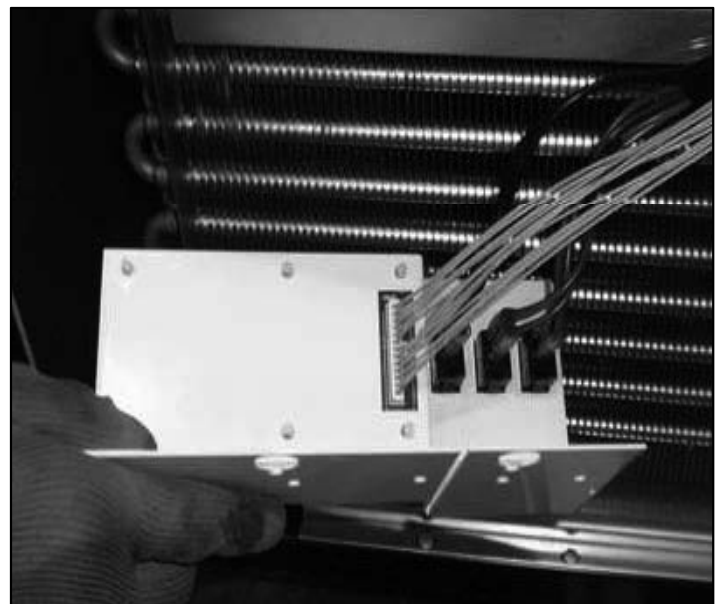

REPLACEMENT OF MAIN COMPONENTS

C . Remove the Electrical Box Cover.

- . Remove the two screws and pull out the Switch Box ASSY.

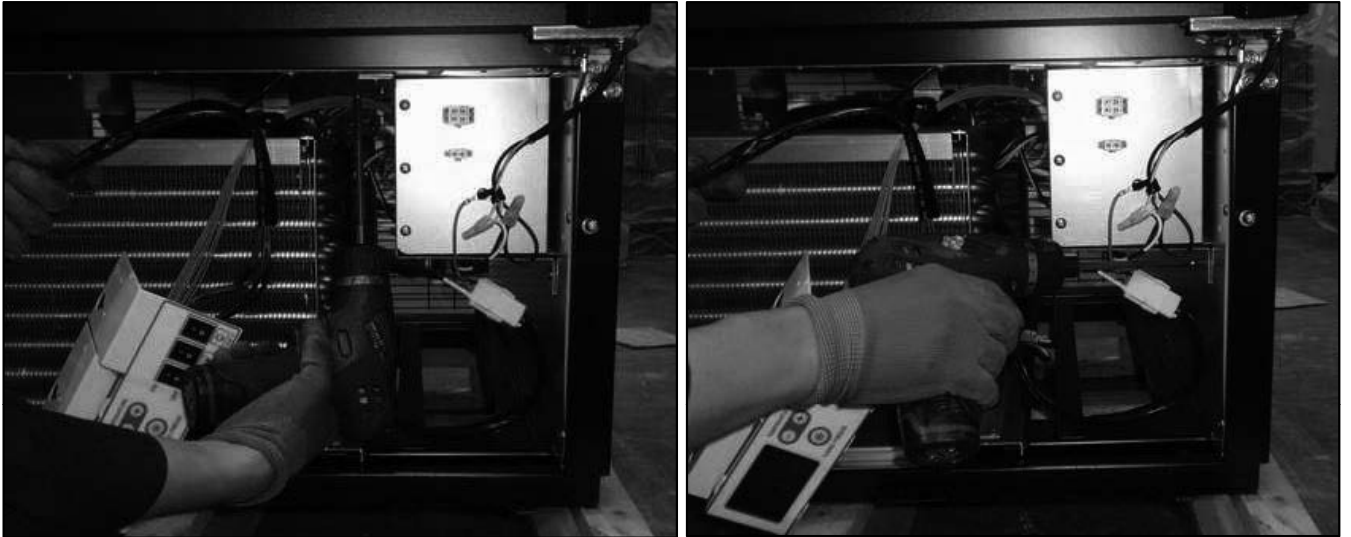

- . Replace the Main PCB & SMPS & Power Relay

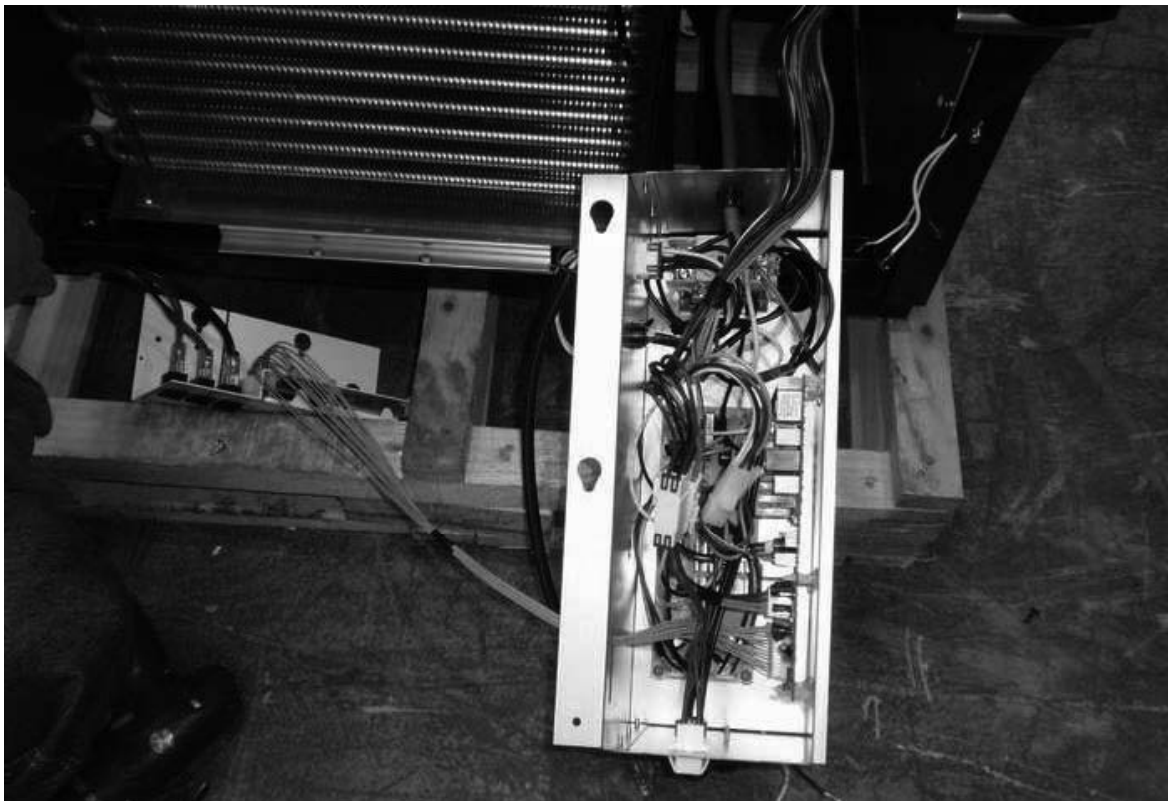

REPLACEMENT OF MAIN COMPONENTS

D . Replace the Condensing Unit

- . Remove the two screws and pull out the Condensing Unit.

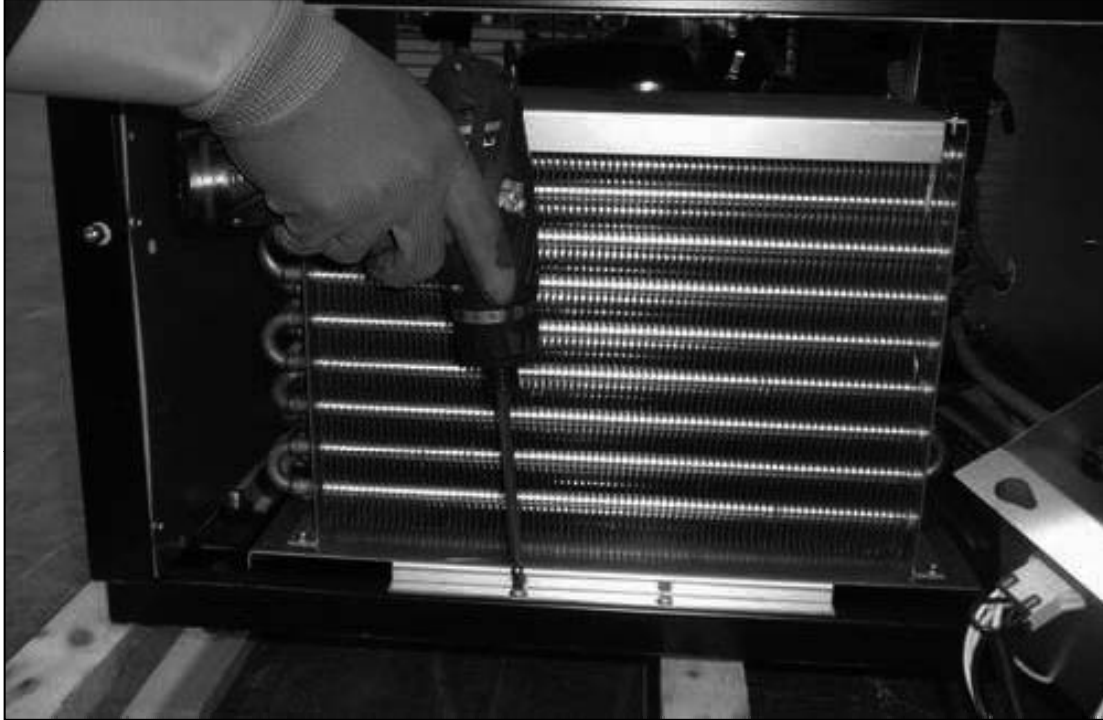

- . Replace the Compressor & Condenser & Condenser Fan Motor.



REPLACEMENT OF MAIN COMPONENTS

7-3-2. SIGN PANEL PARTS

- SIGN PANEL ASSY, LIGHT GUIDE PANEL
- SPEAKER
- DOOR SWITCH

A . Remove the four screws and lift the Sign Panel Assy.

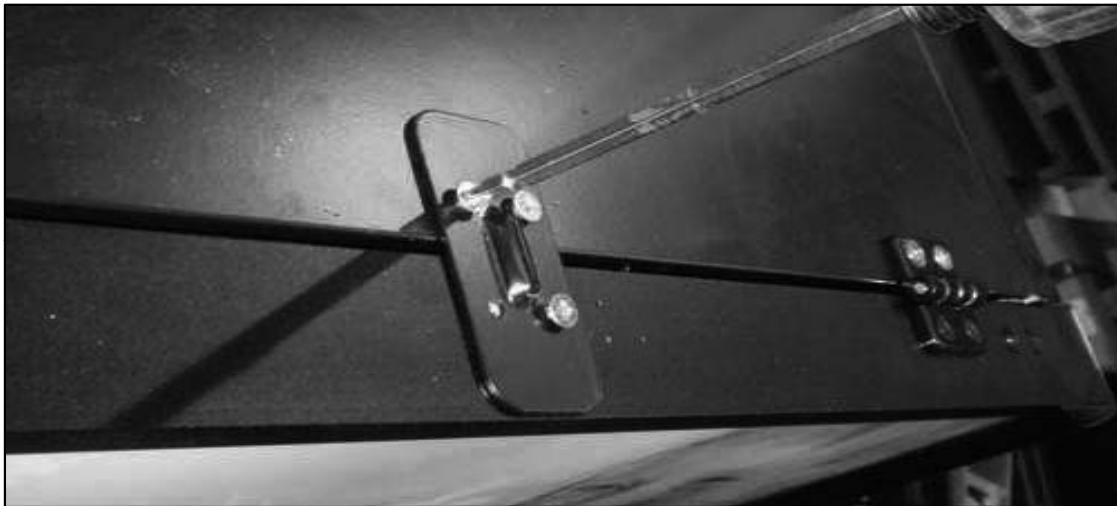

B . Replace the Light Guide Panel & Speaker & Door Switch.



REPLACEMENT OF MAIN COMPONENTS

7-3-3. DOOR PARTS

A . Remove the three screws on the top hinge.



B . Disconnect the two wires and Remove the four screws on the bottom hinge.

=> There is no wire heater in the SD Refrigerator(TGM-15SD*, TGM-23SD*)



C . Replace the Door ASSY.

REPLACEMENT OF MAIN COMPONENTS

7-3-4. REFRIGERATION COMPARTMENT PARTS.

A . Remove the screws on the Duct(A) and (B)



**B . Replace the Evaporator & Evaporator Fan Motor
& Sensors & Sheath Heater.**

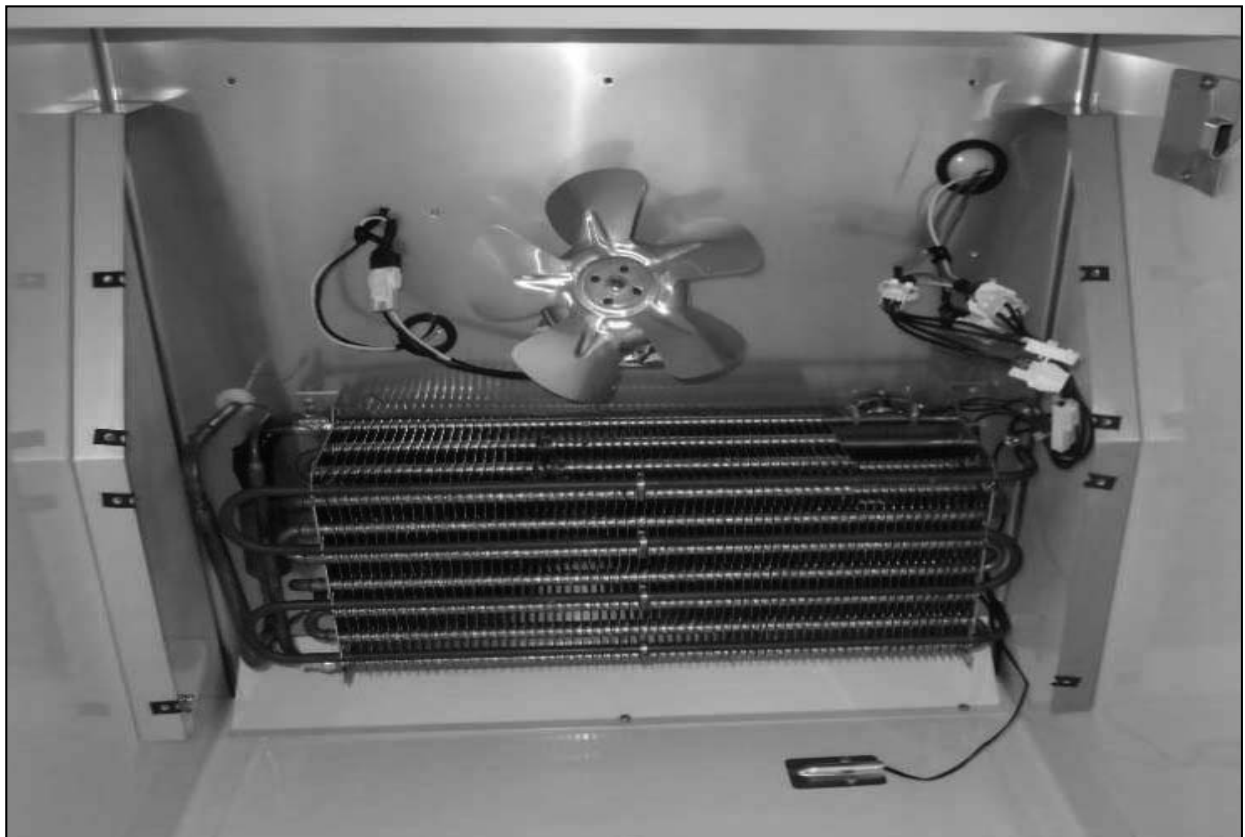

REPLACEMENT OF MAIN COMPONENTS

7-3-5. LED LAMP

A . Remove the two screws on the LED COVER.



B . Disconnect the two wires and Replace the LED LAMP.



REPLACEMENT OF MAIN COMPONENTS

7-4. TGM-35SD*, TGM-47SD*, TGM-72SD*, TGF-35SD*, TGF-47SD*, TGF-72SD*

7-4-1. BOTTOM GRILLE PARTS

- MAIN PCB, SMPS, POWER RELAY
- DISPLAY PCB, LAMP SWITCH, POWER SWITCH
- COMPRESSOR, CONDENSER, CONDENSER FAN MOTOR.

A. Lift and pull out the Bottom Grill



B. Remove the two screws and Replace the Display PCB and Switch. (Power Switch, Lamp Switch)



REPLACEMENT OF MAIN COMPONENTS

7-4-2. SIGN PANEL PARTS

- SIGN PANEL ASSY, LIGHT GUIDE PANEL
- SPEAKER, DOOR SWITCH
- SMPS(for LED in the interior part)

A . Remove the four screws and lift the Sign Panel Assy.

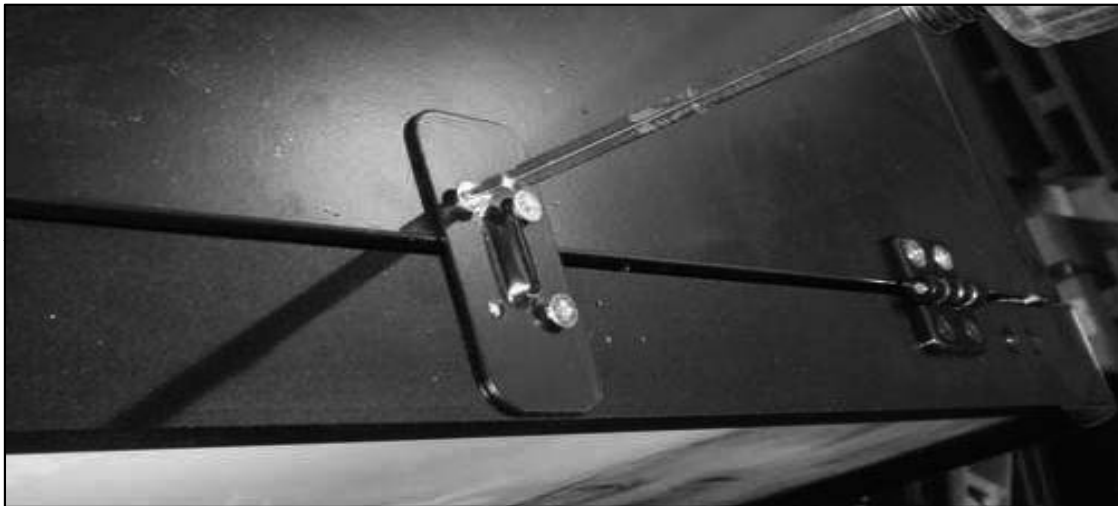

B . Replace the Light Guide Panel & Speaker & Door Switch & SMPS

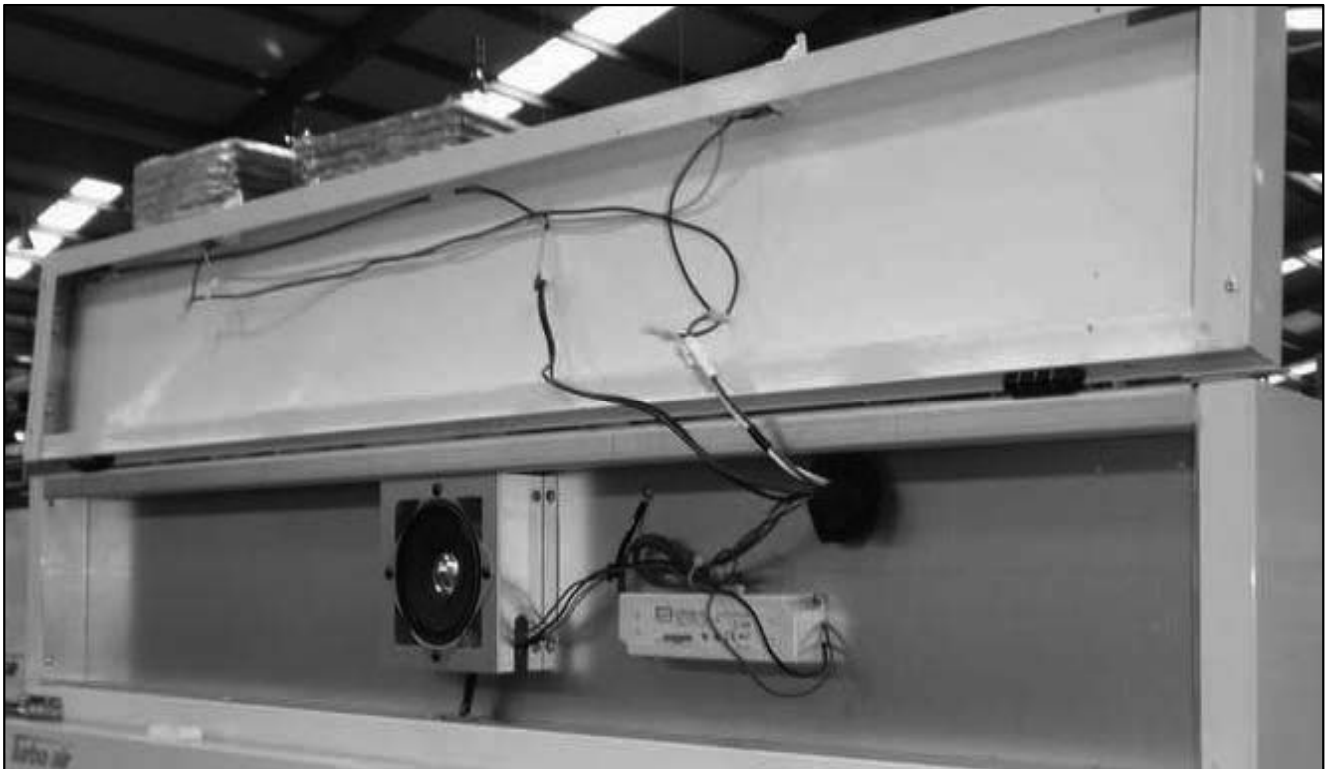

REPLACEMENT OF MAIN COMPONENTS

7-4-3. DOOR PARTS

A . Remove the three screws on the top hinge.



B . Disconnect the two wires and Remove the four screws on the bottom hinge.

=> There is no wire heater in the SD Refrigerator(TGM-47SD*, TGM-72SD*)



C . Replace the Door ASSY.

REPLACEMENT OF MAIN COMPONENTS

7-4-4. REFRIGERATION COMPARTMENT PARTS.

A . Remove the screws on the Duct(A) and (B)



**B . Replace the Evaporator & Evaporator Fan Motor
& Sensors & Sheath Heater.**

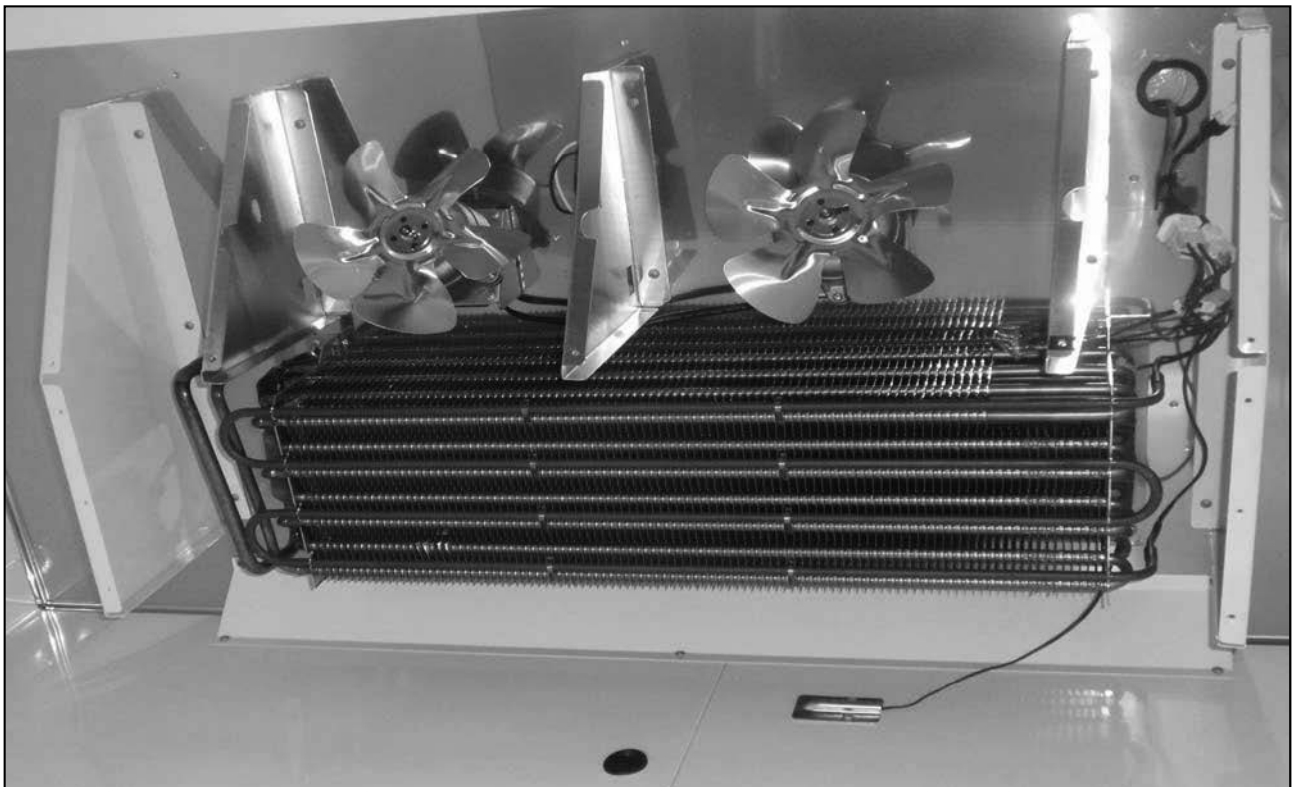

REPLACEMENT OF MAIN COMPONENTS

7-4-5. LED LAMP

A . Disconnect the two wires the rear of the Sign Panel.



B . Replace the LED LAMP.

