

REFRIGERATOR MANUFACTURER
Turbo air

Turbo Air Speed up the Pace of Innovation

CAUTION!
PLEASE KEEP POWER
SWITCH ON BEFORE
OPERATING THIS EQUIPMENT

Glass Door Merchandisers Service Manual

Please read this manual completely before attempting to install or operate this equipment!

TGM-5R
TGM-11RV
TGM-14RV
TGM-22RV(B)
TGM-50RS(B)
TGM-72RS(B)
TGM-35R
TGM-48R(B)
TGM-69R(B)

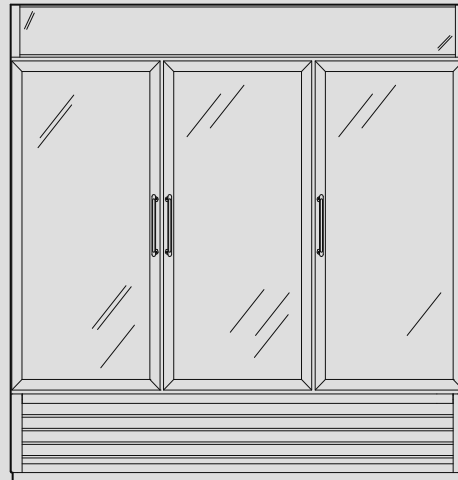

TABLE OF CONTENTS

<REFRIGERATOR>

1. FEATURE CHART
2. WIRING DIAGRAM
3. REFRIGERANT CYCLING DIAGRAM
4. SPECIFICATION OF MAIN COMPONENTS
5. PARTS DIAGRAM
 1. CASTER PARTS
 2. COMPRESSOR PARTS
 3. DOOR PARTS
 4. EVAPORATOR PARTS
 5. LIGHTING PARTS
 6. SHELF PARTS
 7. ADVERTISING & ADVERTISING FRAME PARTS
 8. GRILL PARTS
6. PARTS LIST
7. REPLACEMENT OF MAIN COMPONENTS
 1. LAMP
 2. THERMOSTAT AND LIGHT SWITCH
 3. COOLING FAN MOTOR & BLADE
 4. CONDENSER FAN MOTOR & BLADE
 5. DOOR

1. FEATURE CHART

• Model : TGM-72RS

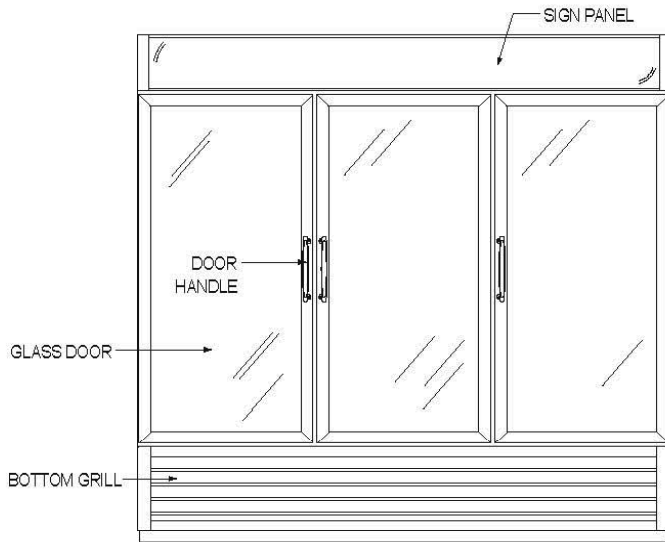

< FRONT >

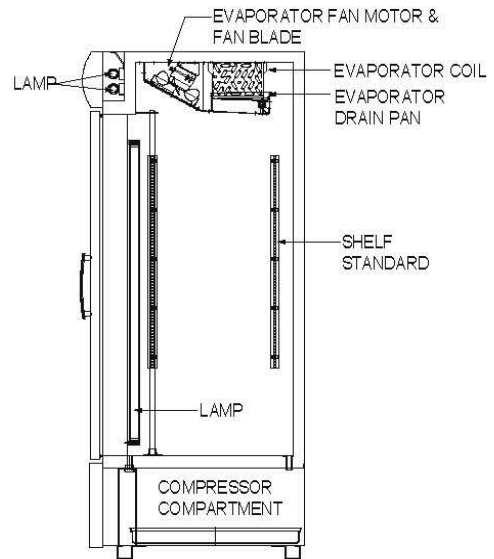

< SIDE >

• Model : TGM-50RS

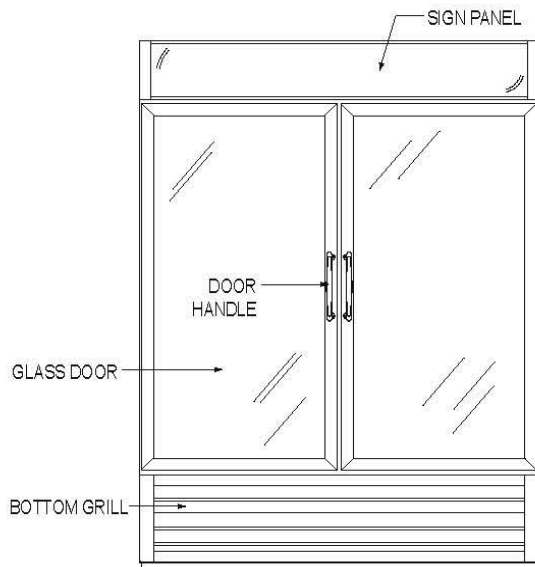

< FRONT >

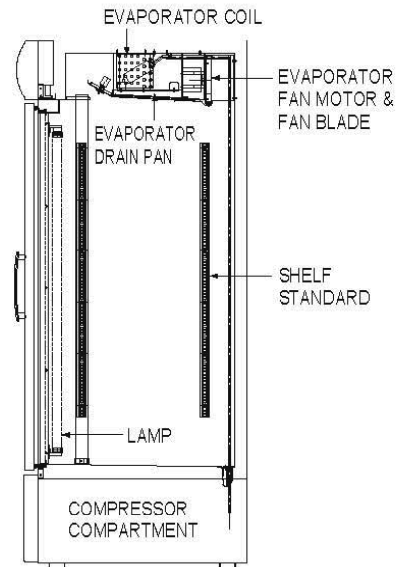

< SIDE >

FEATURE CHART

• Model : TGM-69R

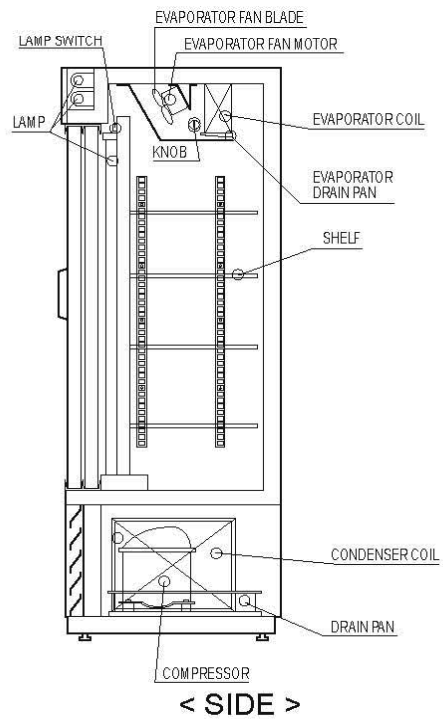
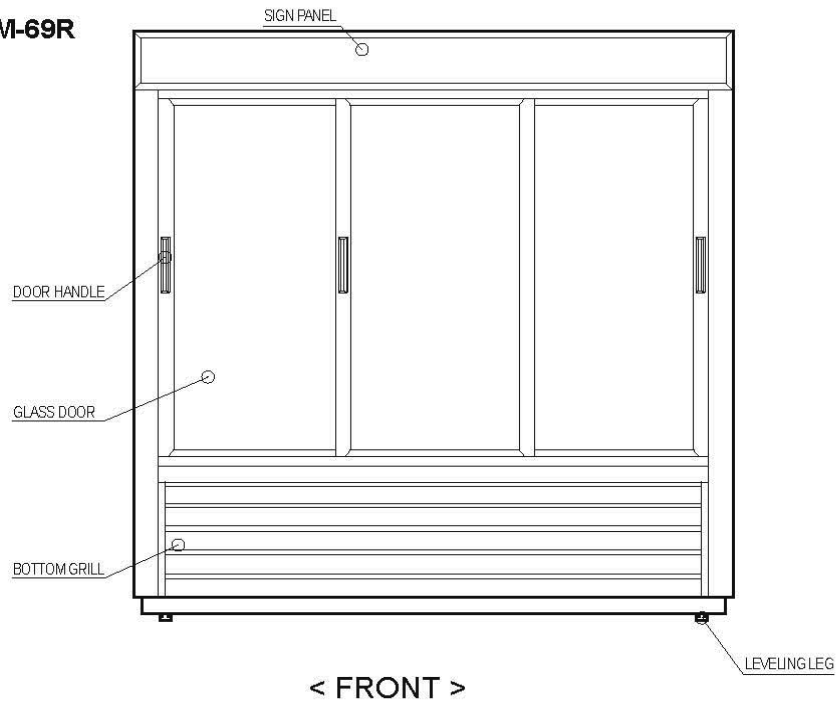

FEATURE CHART

• Model : TGM-48R, 35R

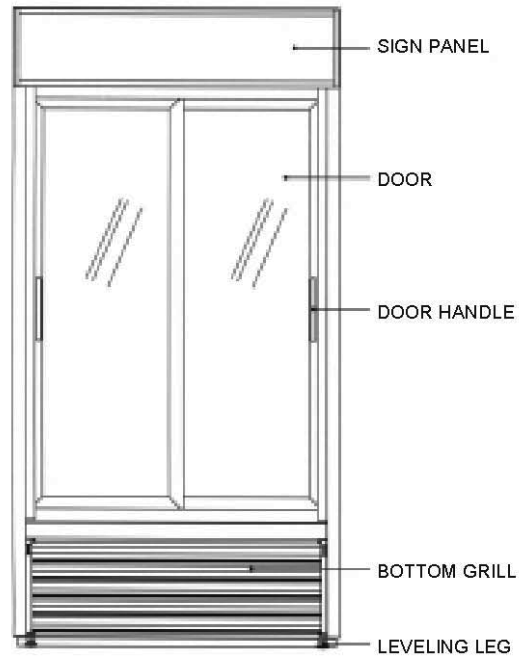

< FRONT >

• Model : TGM-48R, 35R

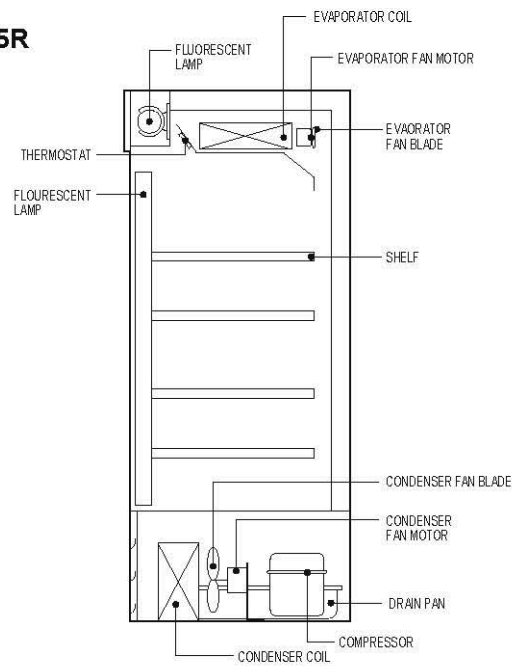

< SIDE >

FEATURE CHART

• Model : TGM-22R

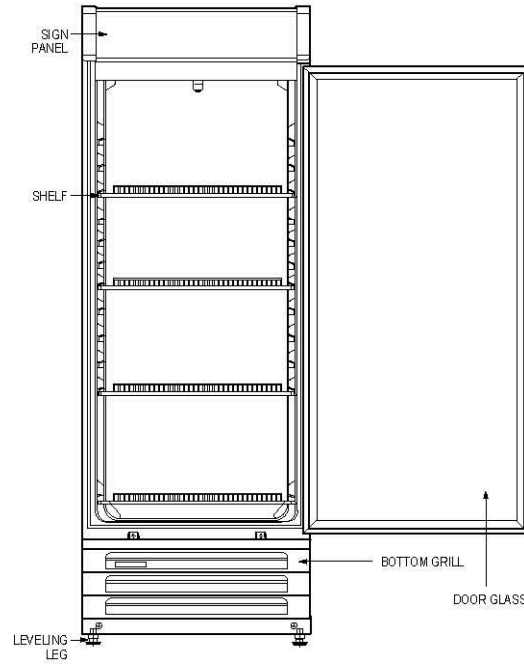

< FRONT >

• Model : TGM-22R

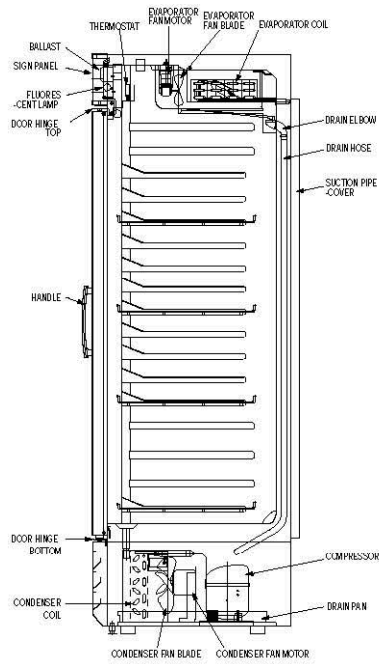

< SIDE >

FEATURE CHART

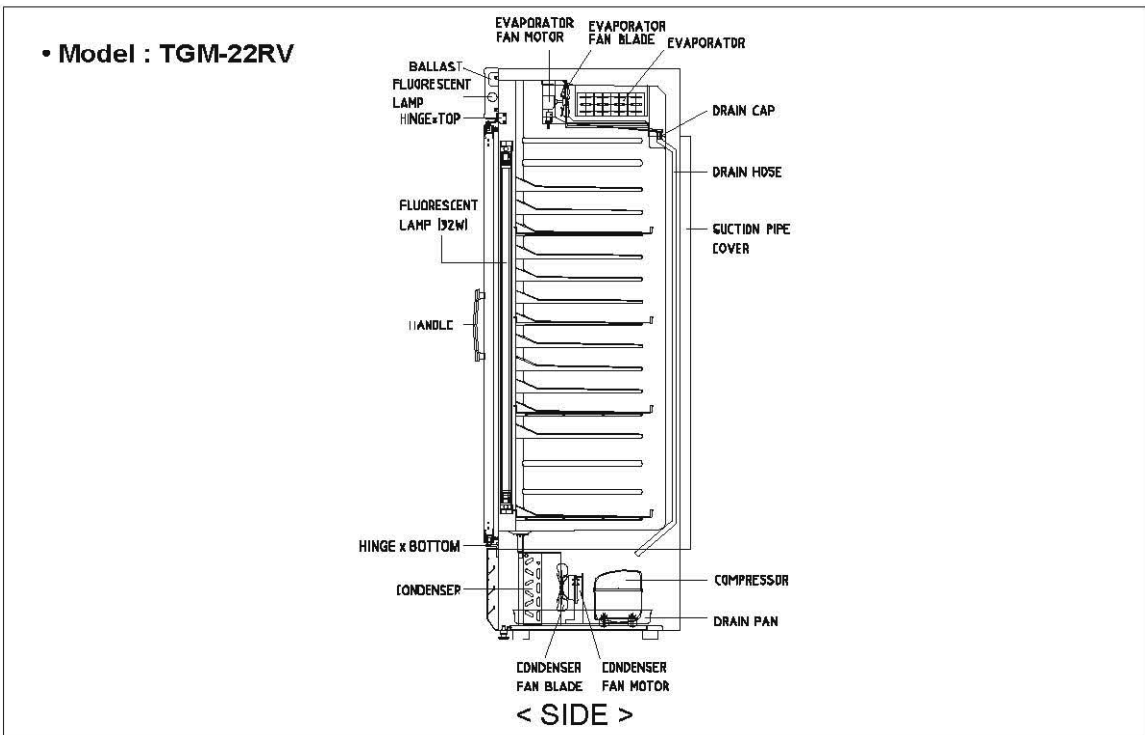
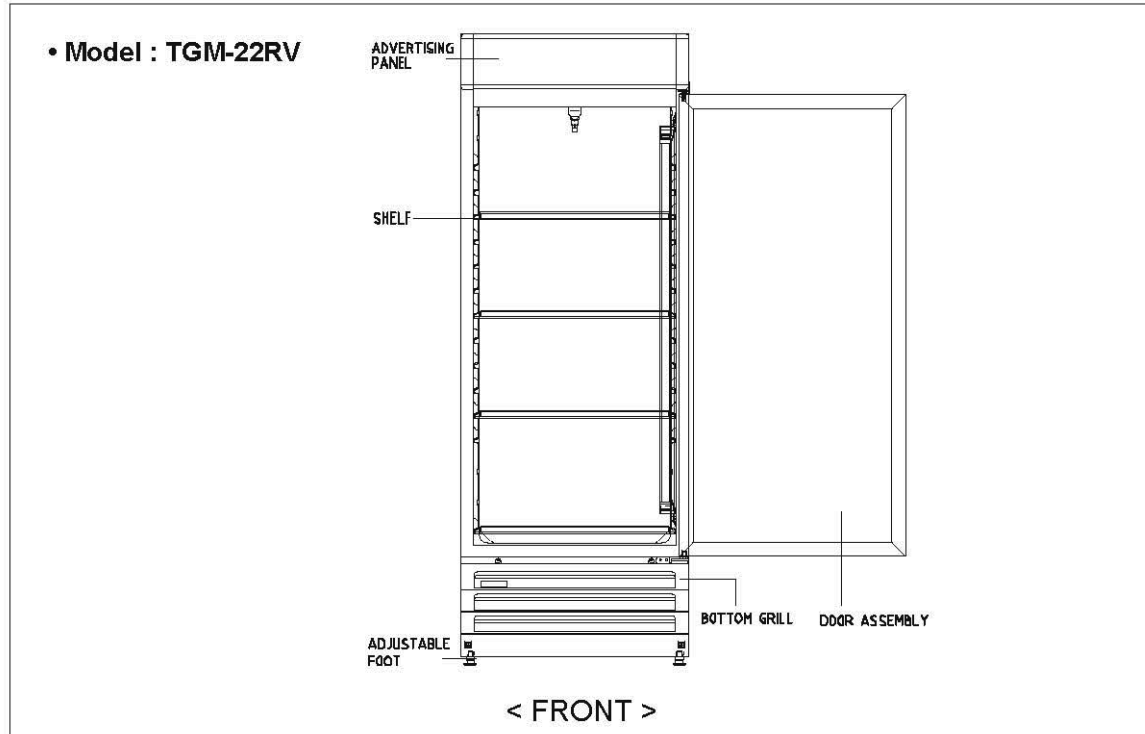

FEATURE CHART

• Model : TGM-14R

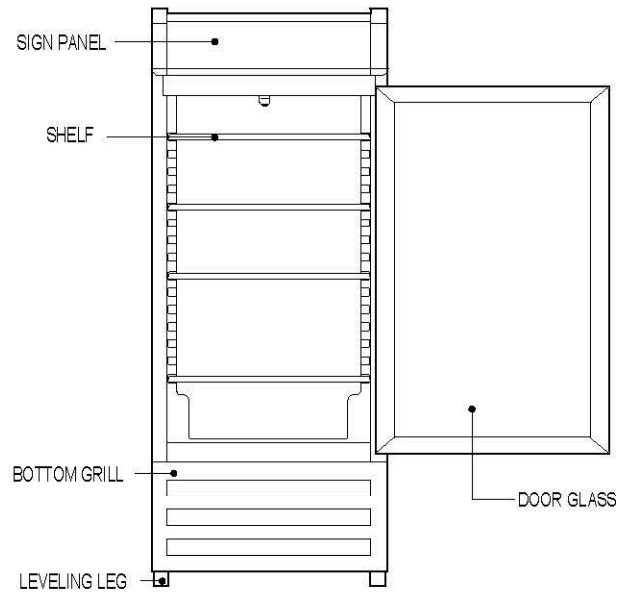

< FRONT >

• Model : TGM-14R

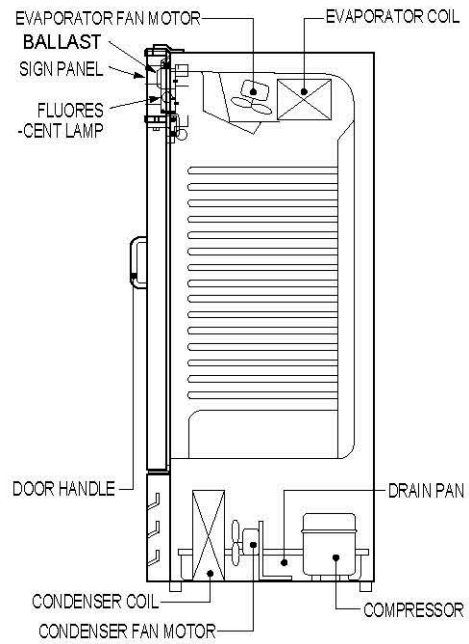

< SIDE >

FEATURE CHART

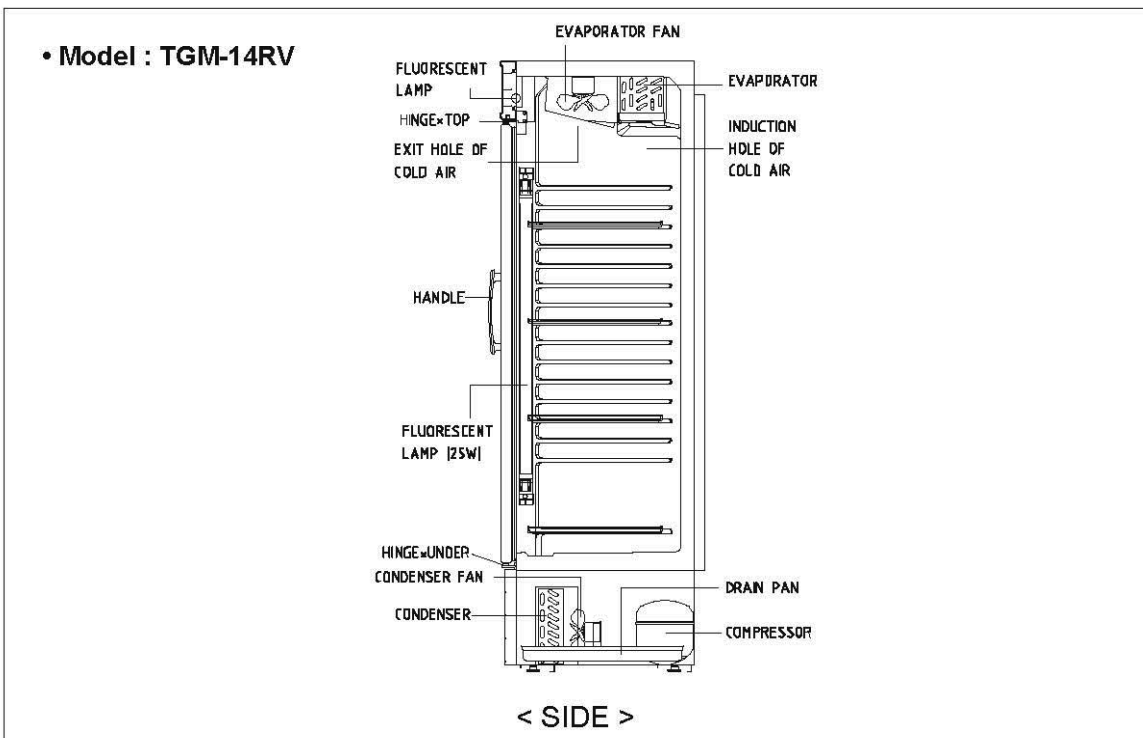
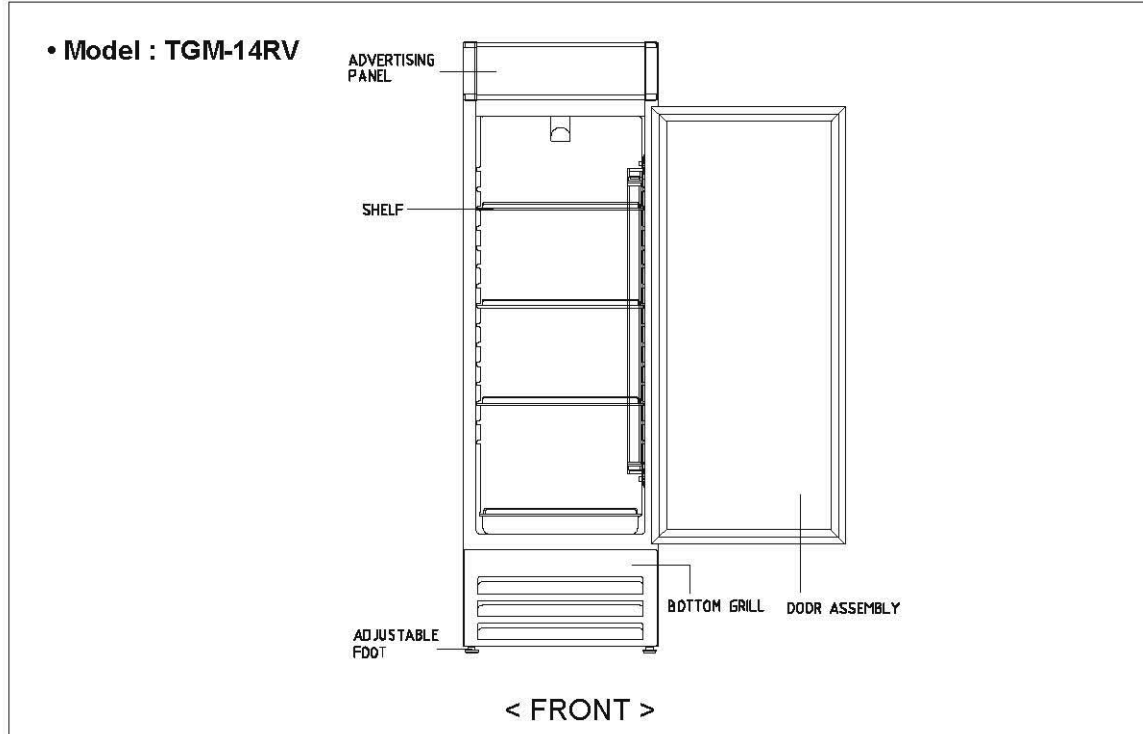

FEATURE CHART

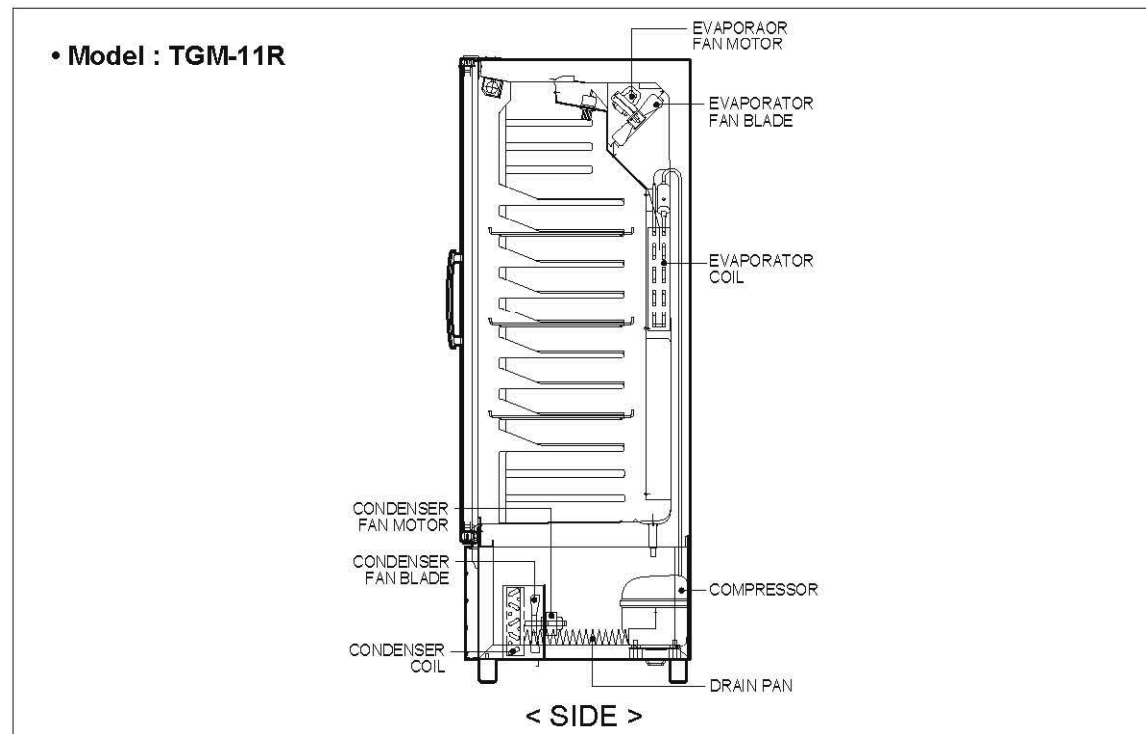
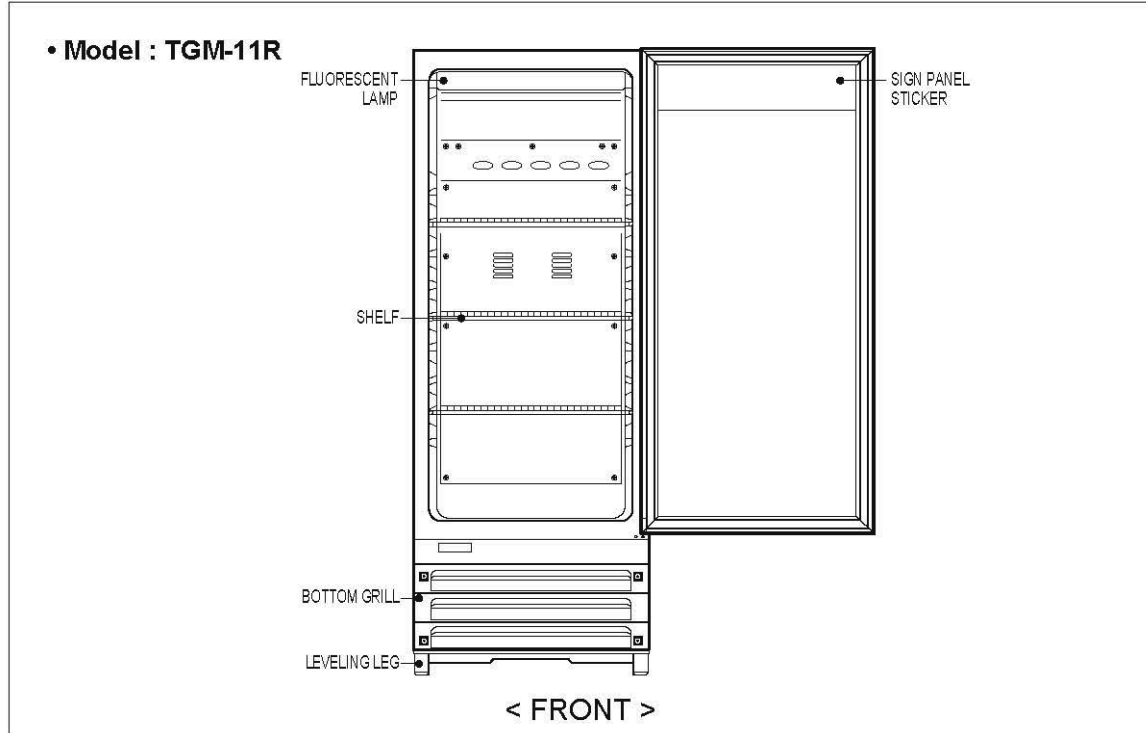

FEATURE CHART

• Model : TGM-5R

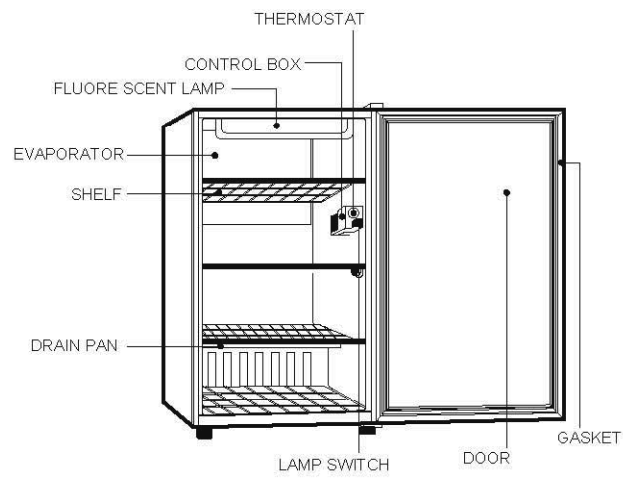

< FRONT >

• Model : TGM-5R

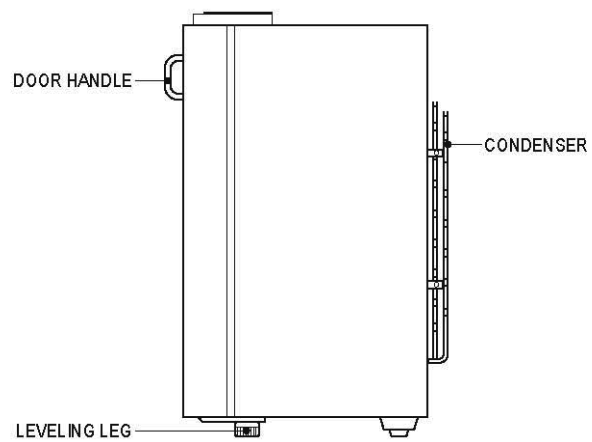

< SIDE >

FEATURE CHART

• Model : TGM-5R

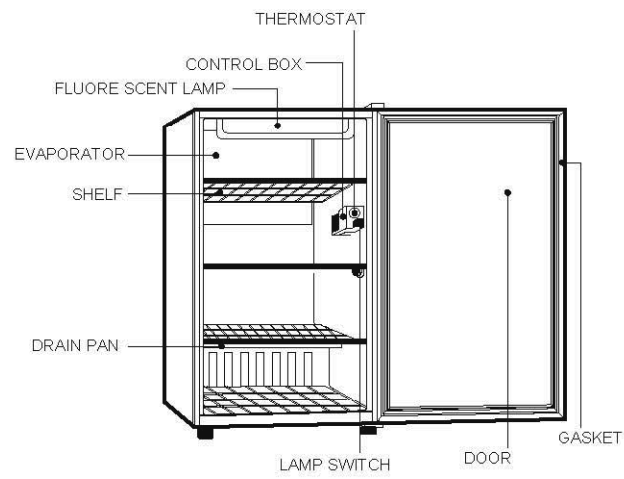

< FRONT >

• Model : TGM-5R

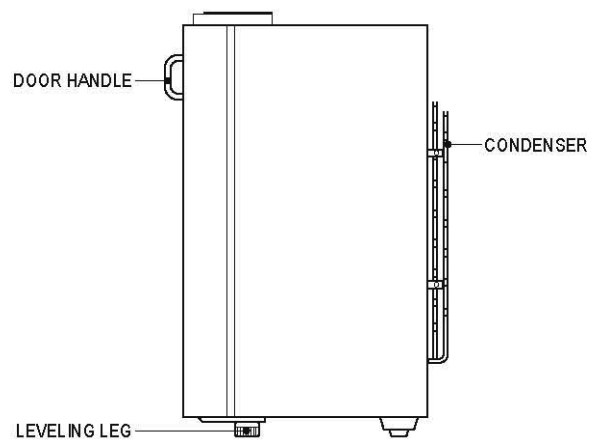

< SIDE >

2. WIRING DIAGRAM

- Model : TGM-69R, TGM-72RS

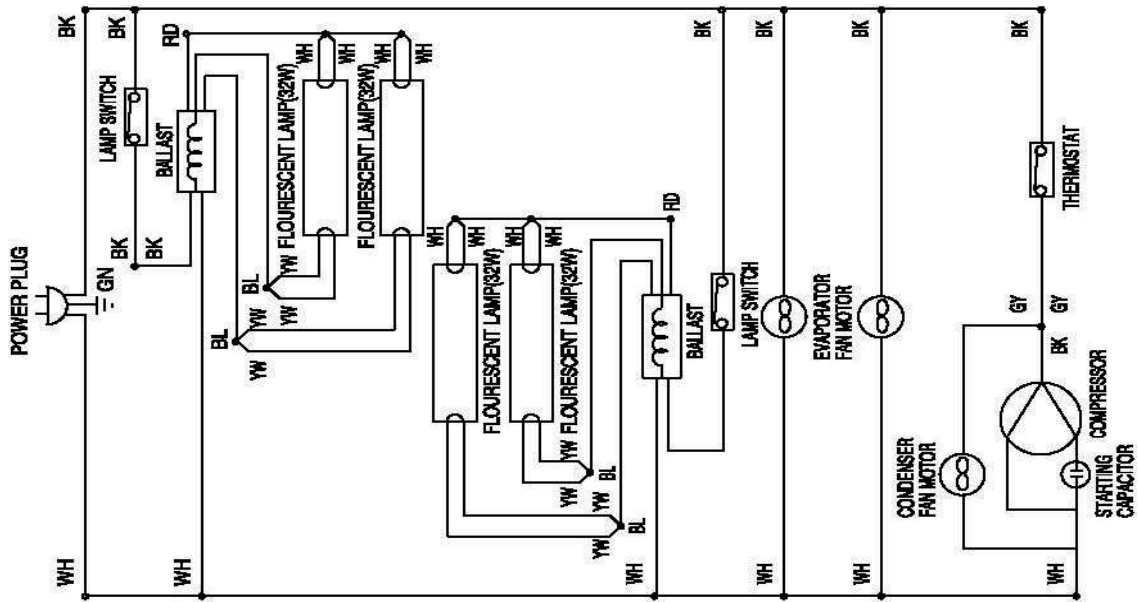

- Model : TGM-48R, TGM-50RS, TGM-35R

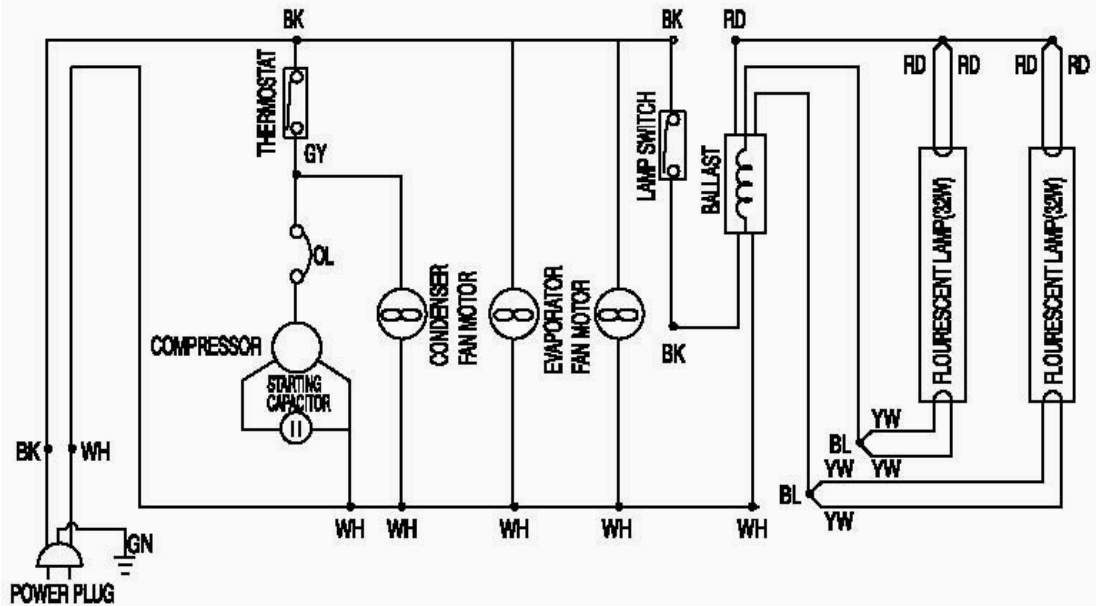

WIRING DIAGRAM

- Model : TGM-22R

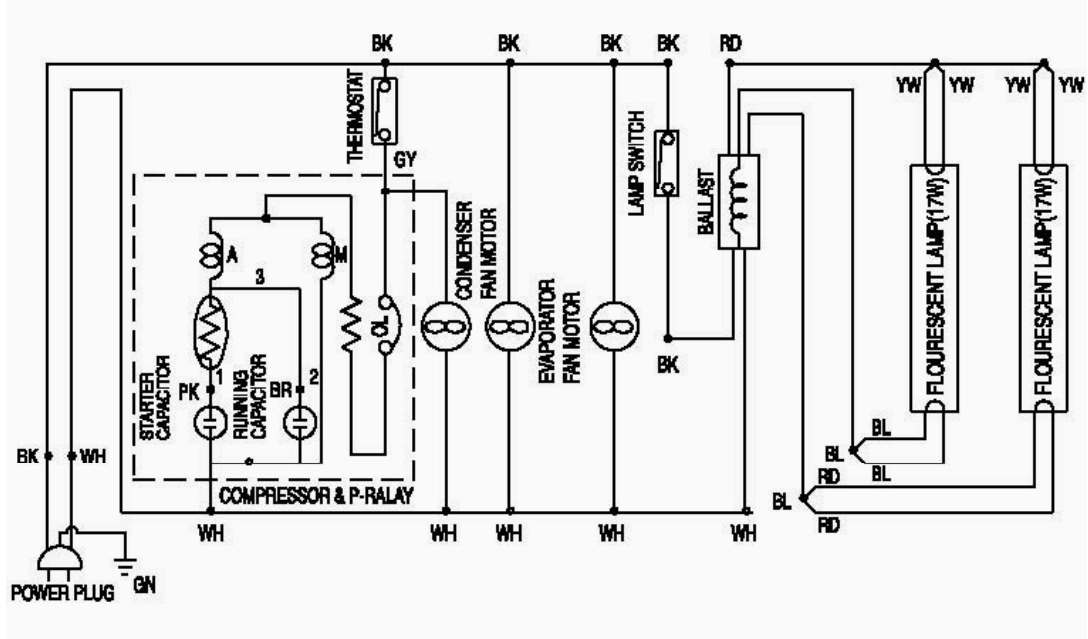

- Model : TGM-22RV

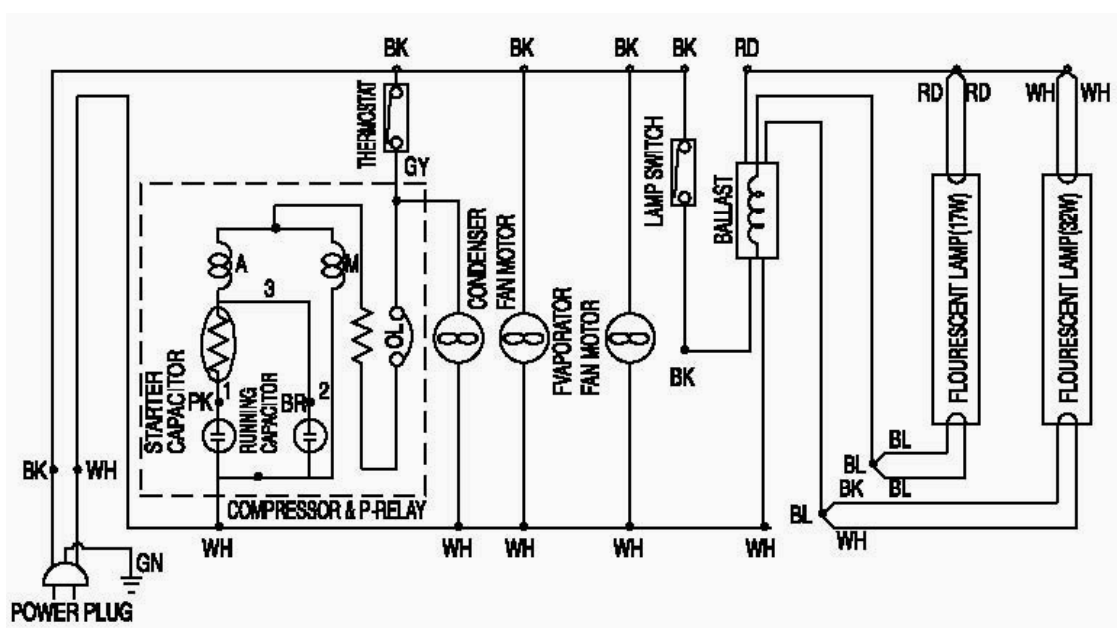

WIRING DIAGRAM

- Model : TGM-14R

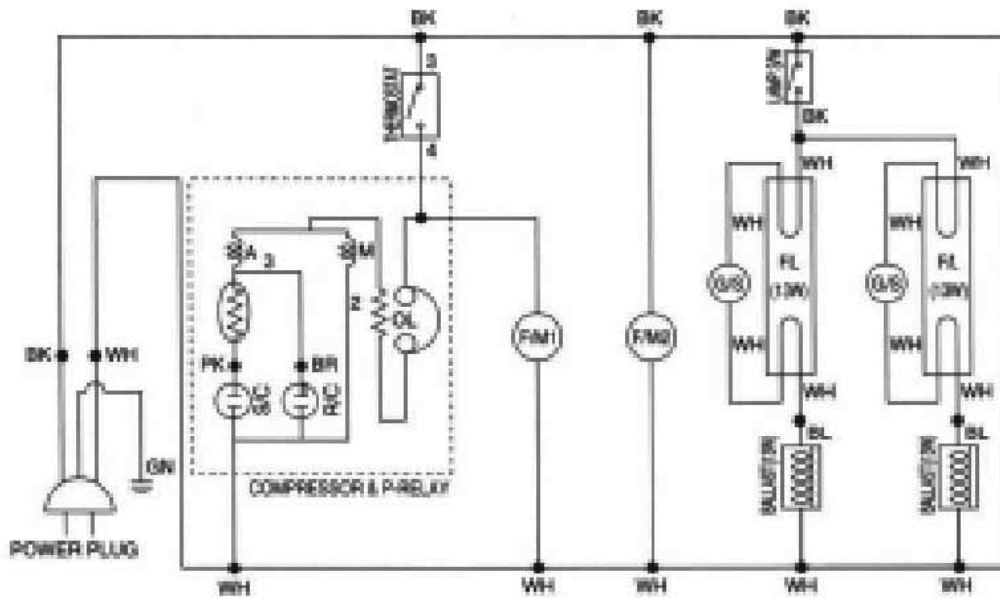

- Model : TGM-14RV

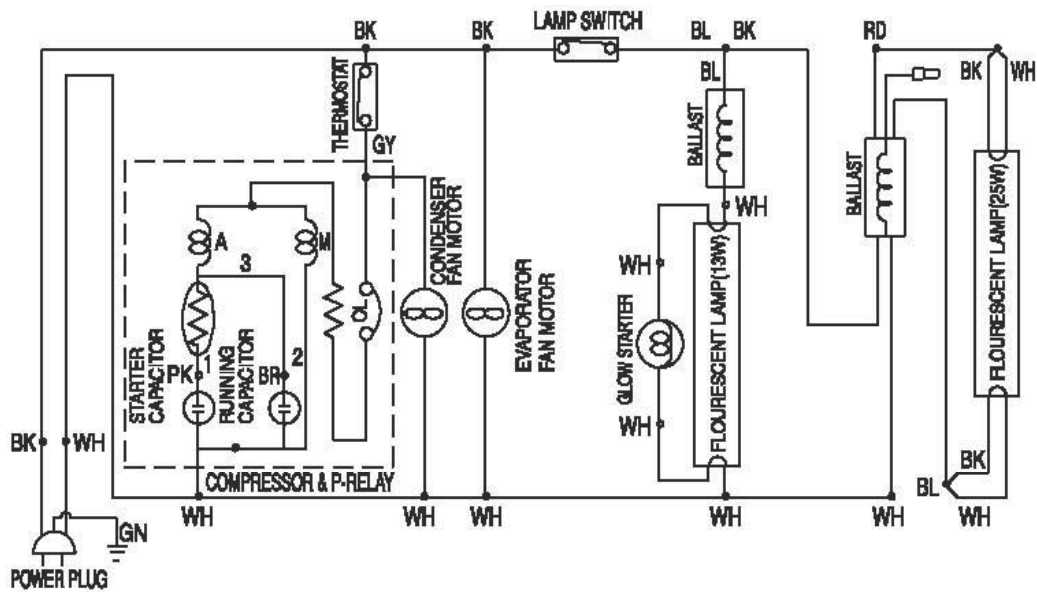

WIRING DIAGRAM

• Model : TGM-11R

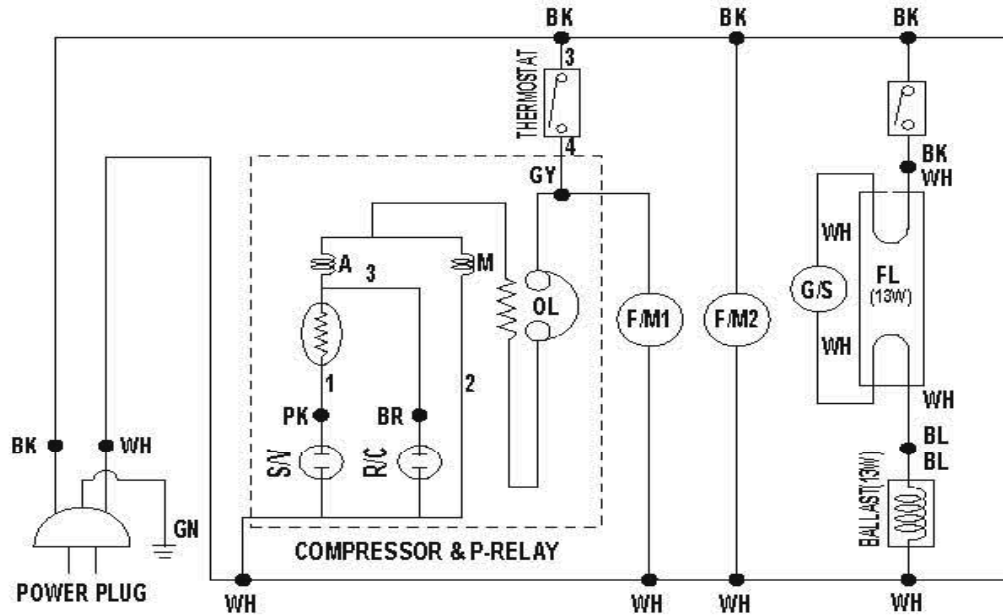

• Model : TGM-11RV

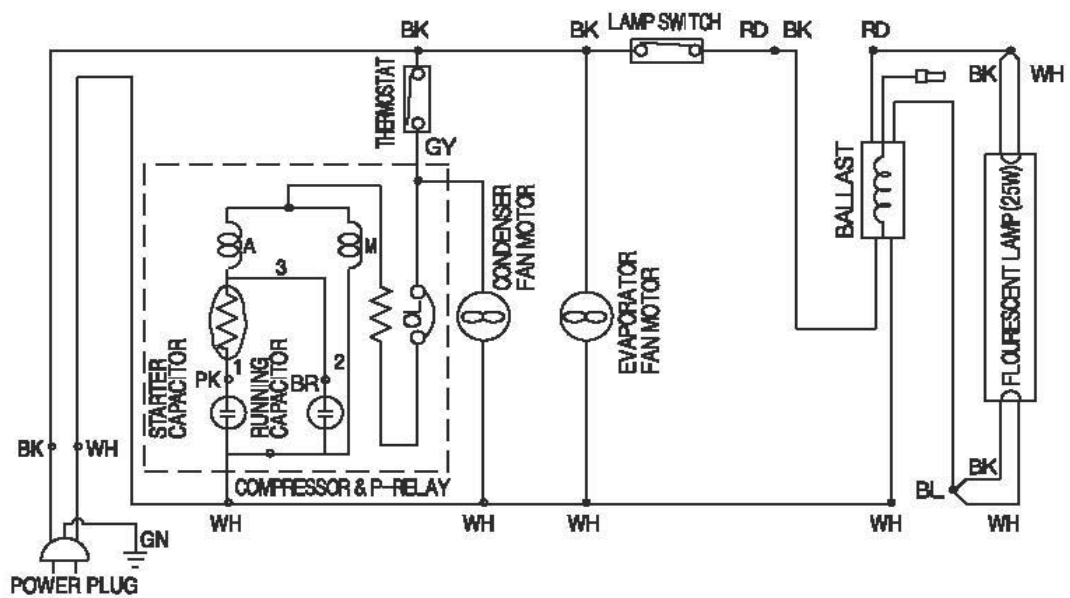

WIRING DIAGRAM

- Model : TGM-5R

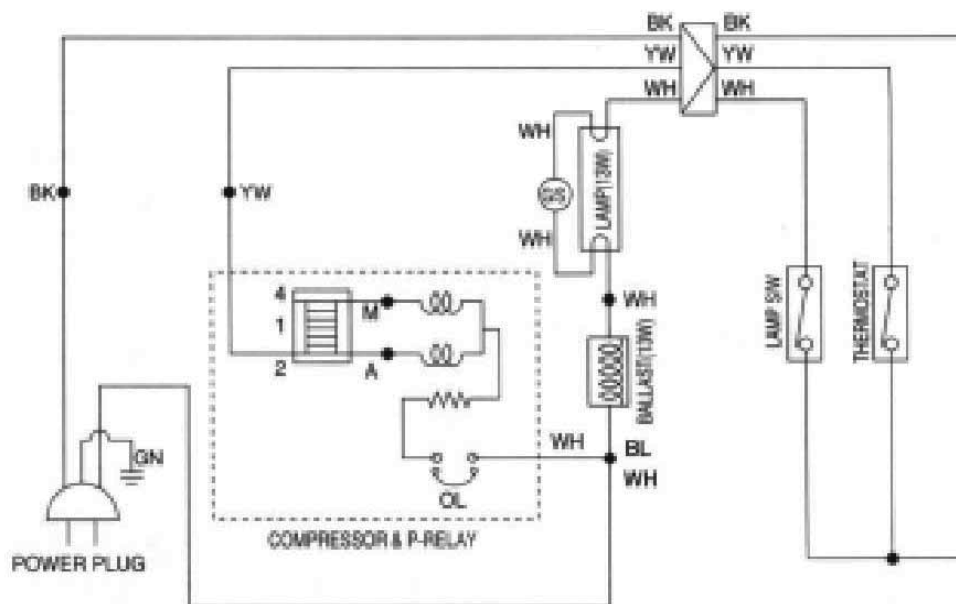

3. REFRIGERANT CYCLE DIAGRAM

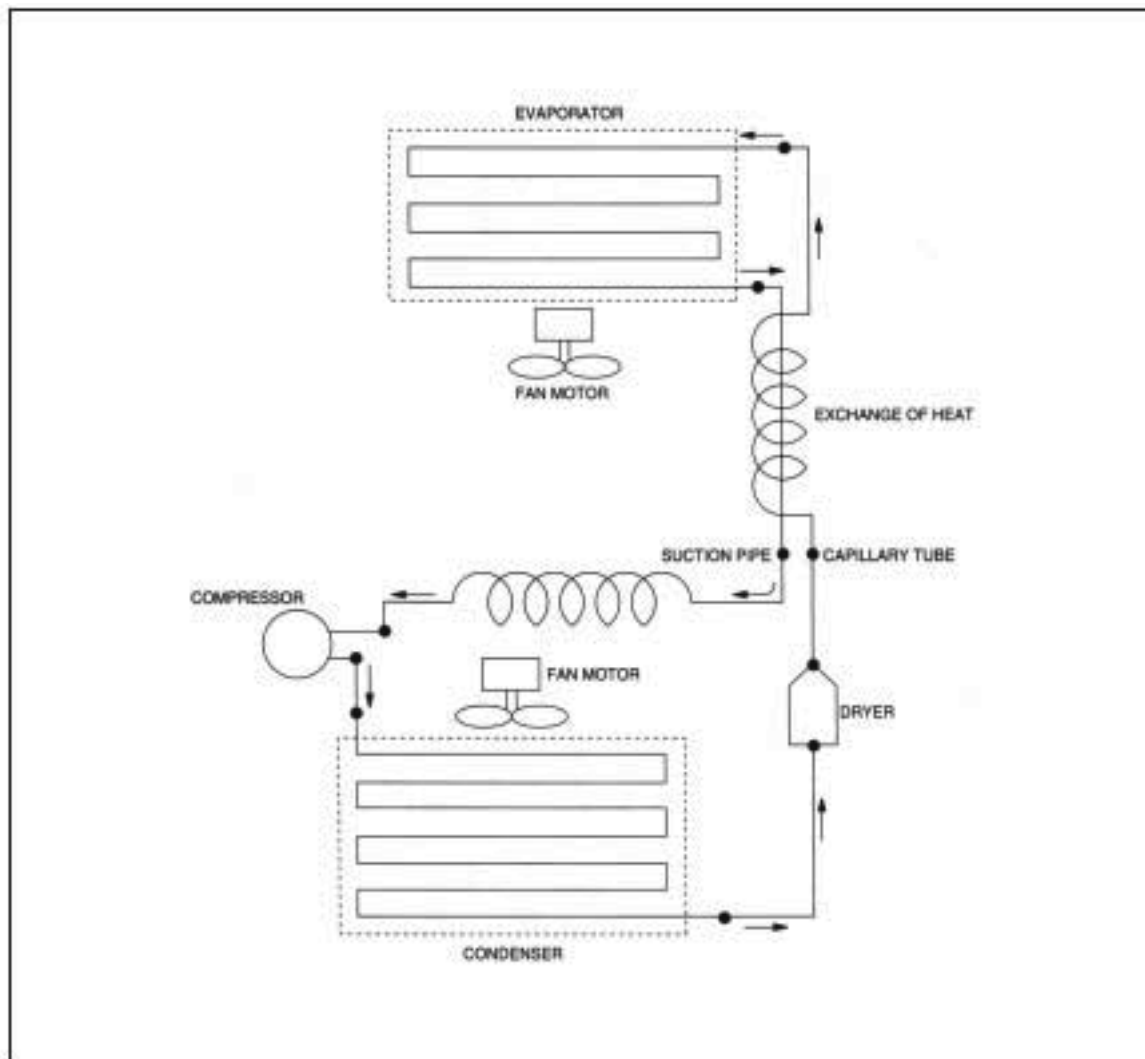

- Refrigerant for all models : R-134A (CFC Free)

4. SPECIFICATION OF MAIN COMPONENTS

1. COMPRESSOR

MODEL	PART NAME	PART NO.	HORSE POWER	CAPACITY	TYPE OF MOTOR	Current (RLA)	MAKER
TGM-69R TGM-72RS	T6217Z	3020014570	2/3 HP	7,638 BTU/h (1,925 Kcal/h)	HBP CSIR	11.2A	EMBRACO
TGM-48R TGM-50RS TGM-35R	CAJ4476Y	30200A4710	2/3 HP	7,717 BTU/h (1,946 Kcal/h)	HBP CSIR	11.0A	TECUMSEH
TGM-22R/RV TGM-14R/RV TGM-11R/RV	HBL27YE-1	3952127G10	1/4 HP	896 BTU/h (226 Kcal/h)	LBP CSR	3.7A	DAEWOO
TGM-5R	HFL11Y-1	3953111E10	1/10 HP	874 BTU/h (95 Kcal/h)	LBP RSIR	1.9A	DAEWOO

	BASIC COMPRESSOR			EXCHANGEABLE COMPRESSOR		
	PART NAME	MOTOR TYPE	MAKER	PART NAME	MOTOR TYPE	MAKER
TGM-69R/72RS	T6217Z	HBP(CSIR)	EMBRACO	AKA4476YXA	HBP(CSIR)	USA TECUMSEH
TGM-48R/50RS TGM-35R	CAJ4476Y	HBP(CSIR)	FRENCH TECUMSEH	AKA4476YXA	HBP(CSIR)	USA TECUMSEH
TGM-22R/RV TGM-14R/RV TGM-11R/RV	HBL27YE-1	LBP(CSR)	DAEWOO	AEA1410YXA	LBP(RSIR)	USA TECUMSEH
TGM-5R	HFL11Y-1	LBP(RSIR)	DAEWOO	AEA3414YXA	HBP(RSIR)	USA TECUMSEH

2. COMPRESSOR RELAY, OVERLOAD

MODEL	RELAY	PART NO.	OVERLOAD	PART NO.	MAKER	NOTE
TGM-69R/72RS	9660C-3027	-	MRT00AF	-	EMBRACO	
TGM-48R/50RS TGM-35R	3ARR3	-	CRA38014	-	TECUMSEH	
TGM-22R/RV TGM-14R/RV TGM-11R/RV	PTC S068	30227M3600	4TM-783SHB	3817910601	DAEWOO	
TGM-5R	PTC S068	30227M3600	4TM-293THB	3817906501	DAEWOO	

MAIN COMPONENTS

3. COMPRESSOR CAPACITOR

MODEL	STARTING	PART NO.	RUNNING	PART NO.	MAKER	NOTE
TGM-69R/72RS	330V/189-227 μ F	-	-	-	EMBRACO	
TGM-48R/50RS TGM-35R	160V/250 μ F-	-	-	-	TECUMSEH	
TGM-22R/RV TGM-14R/RV TGM-11R/RV	220V/100 μ F	401RD35050	230V/10 μ F	400EL15130	DAEWOO	
TGM-5R	-	-	-	-	-	

4. CONDENSER FAN MOTOR

MODEL	PART NAME	PART NO.	POLE	INPUT	BLADE	SIZE	MAKER
TGM-69R/72RS TGM-48R/50RS TGM-35R	IS-4420DWSG-1	39633220410	4P	47W	AL 5	250mm	SUNG-SHIN
TGM-22R/RV	IS-4420DWSR-1	3963322900	4P	47W	AL 4	225mm	
TGM-14R/RV	IS-3225DWSQ-2	3963326710	2P	36W	Zytel 6	150mm	
TGM-11R/RV							

5. EVAPORATOR FAN MOTOR

MODEL	PART NAME	PART NO.	POLE	INPUT	BLADE	SIZE	MAKER
TGM-69R/72RS	IS-4420DWSN-2A	3963328120	4P	43W	AL 5	175mm	SUNG-SHIN
TGM-48R/50RS TGM-35R	IS-3220DWSF	3963320502	2P	18W	Zytel 3	150mm	
TGM-22R/RV	IS-3210DWSB-2	3963328610	2P	16W	ABS 4	110mm	
TGM-14R/RV	IS-4420DWSN-2	3963328110	4P	43W	AL 5	175mm	
TGM-11R/RV	IS-3210DWSB-3	3963328620	2P	16W	ABS 4	110mm	

MAIN COMPONENTS

6. THERMOSTAT

MODEL	PART NAME	PART NO.	TYPE	MAKER
TGM-69R	K55-Q5606	30283K0110	C.C.I	RANCO
TGM-48R	K55-Q5605	30283K0100	C.C.I	
TGM-72RS/50RS	K55-Q5602	30283D0700	C.C.I	
TGM-35R				
TGM-22R/RV	GNA-240L-4	30283F0800	NORMAL	SHIN-HAN
TGM-14R/RV				
TGM-11R/RV				
TGM-5R	PFN-110U-02D	3018301001	NORMAL	PACIFIC
	GNF-110U-02D			SHIN-HAN

7. BALLAST

MODEL	PART NAME	PART NO.	QTY	WATT	TYPE	MAKER
TGM-69R/72RS	B232I120RH-A	30200K4200	1	32W(L)	INSTANT	UNIVERSAL
		32000K4300	1	32W(R)		
TGM-48R/50RS	B232I120RH-A	30200H7420	1	32W(2)		
TGM-35R	B232I120RH-A	30200A0180	1	25W,32W		
TGM-22R	B232I120RH-A	30200H7420	1	17W(2)		
TGM-22RV	B232I120RH-A	30200H7420	1	17W,32W		
TGM-14R	DD22B	30200A0141	2	13W(2)	Preheated	DONGDO
TGM-14RV	B232I120RH-A	30200f7320	1	32w	INSTANT	UNIVERSAL
	DD22B	30200A0141	1	13W	Preheated	DONGDO
TGM-11R	DD22B	30200A0141	1	13W	Preheated	DONGDO
TGM-11RV	B232I120RH-A	30200A0160	1	25W,32W	INSTANT	UNIVERSAL
TGM-5R	DD22B	30200A0141	1	13W	Preheated	DONGDO

MAIN COMPONENTS

8. FLUORESCENT LAMP

MODEL	PART NAME	PART NO.	QTY	WATT	LENGTH	BULB	MAKER
TGM-69R/72RS	TLD32W/865	30236D0511	4	32W	48"	T8	PHILIPS or GE
TGM-48R/50RS			2				
TGM-35R			1				
TGM-22R	F25T8/SP41/ECO	30236A0510	1	25W	36"		
TGM-22RV	F17T8/SP41/ECO	30236H0510	2	17W	24"		
TGM-14R	TLD32W/865	30236D0511	1				
TGM-14RV	F13T8/CW	30236F0510	2	13W	12"		
TGM-11R	F25T8/SP41/ECO	30236A0510	1		25W		
TGM-11RV	F13T8/CW	30236F0510	1	13W	12"		
TGM-5R	F25T8/SP41/ECO	30236A0510	1	25W	36"		
TGM-5RV	F13T8/CW	30236F0510	1	13W	12"		

9. LIGHTER STARTER

MODEL	PART NAME	PART NO.	BASE	MAKER
TGM-14R/RV	FS-2	30206A0700	P21	OPO
TGM-11R				
TGM-5R				

10. LAMP SWITCH

MODEL	TYPE	RATING	PART NO.	MAKER
ALL	ROCKER SWITCH	125V/15A	30281Q0101	LIGHT COUNTRY

5. PARTS DIAGRAM

1. CASTER or LEVELING LEG PARTS

- Model : TGM-69R, 72RS, 48R, 50RS, 35R,22R,14R,14RV(Option)

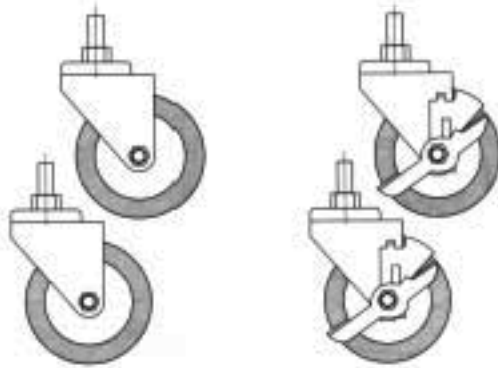

Castors



LEVELING LEG
(TGM-14R,
14RV,11R, 11RV)



LEVELING LEG
(TGM-5R)

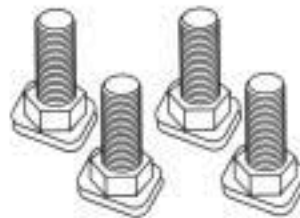

LEVELING LEG
(TGM-69R, 48R, 45R, 35R, 33R, 22R,
22RV)

2. COMPRESSOR PARTS

• Model : TGM-69R, 72RS, 48R, 50RS, 35R

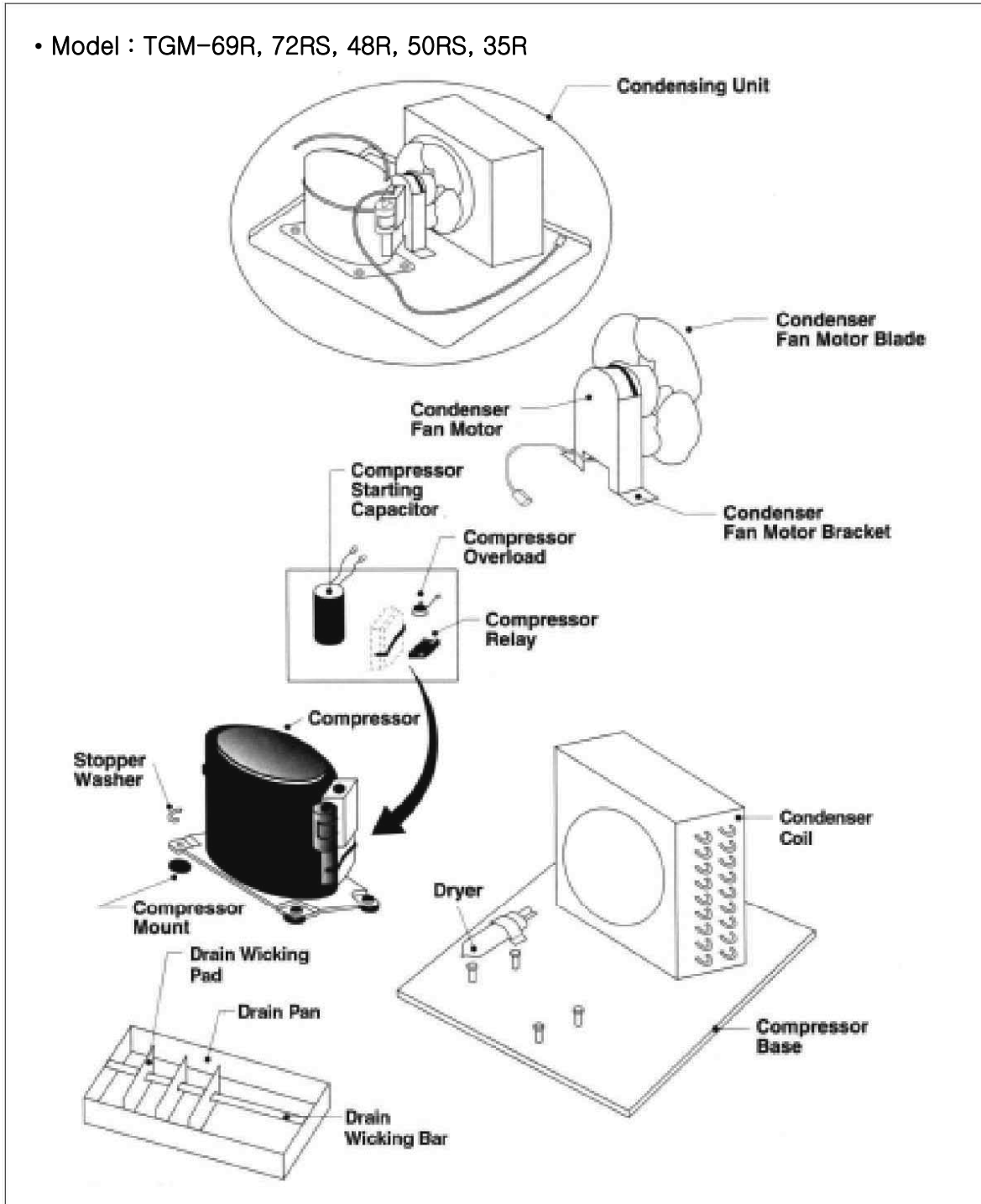

PARTS DIAGRAM

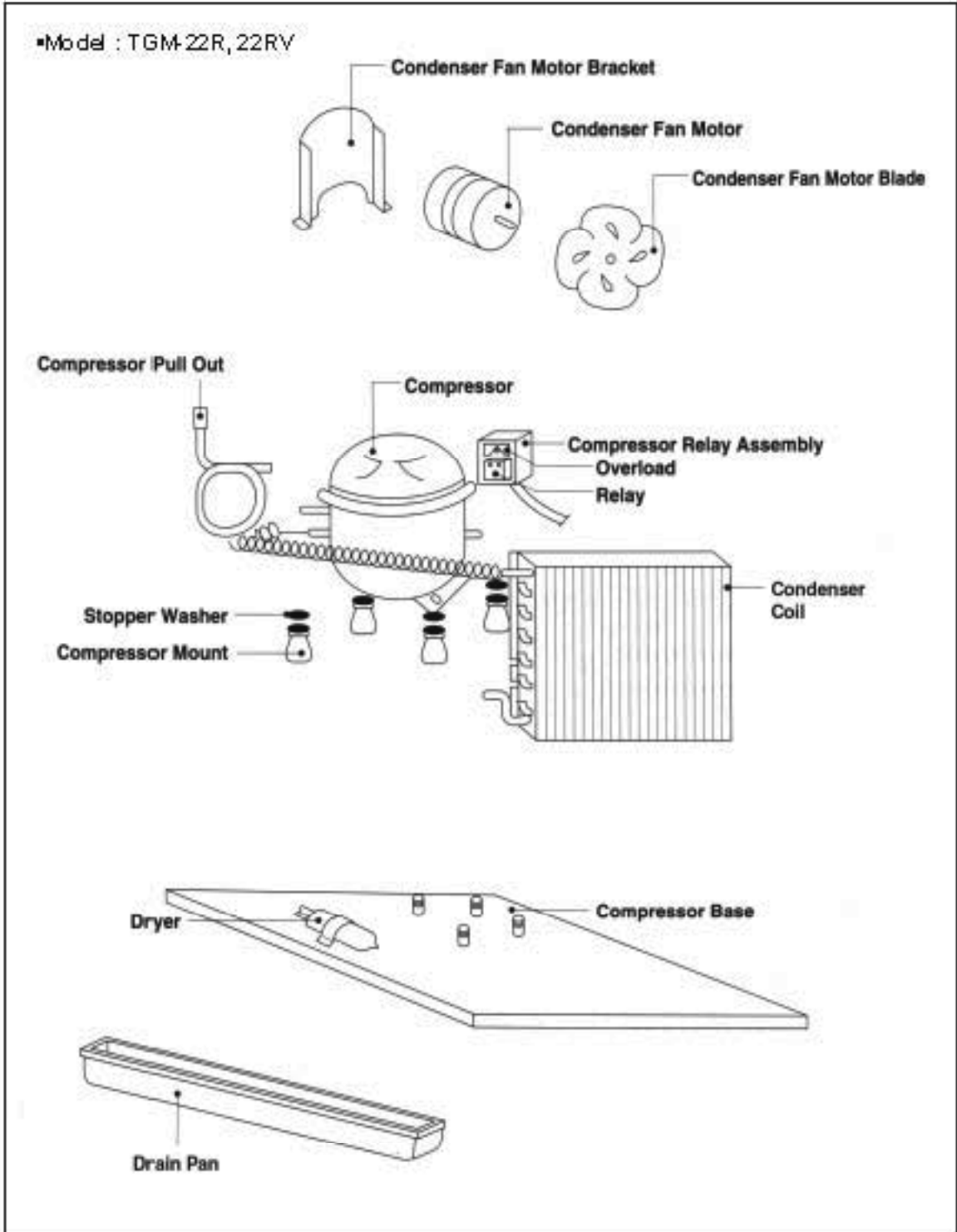

PARTS DIAGRAM

•Model : TGM-14R, 14RV, 11R, 11RV

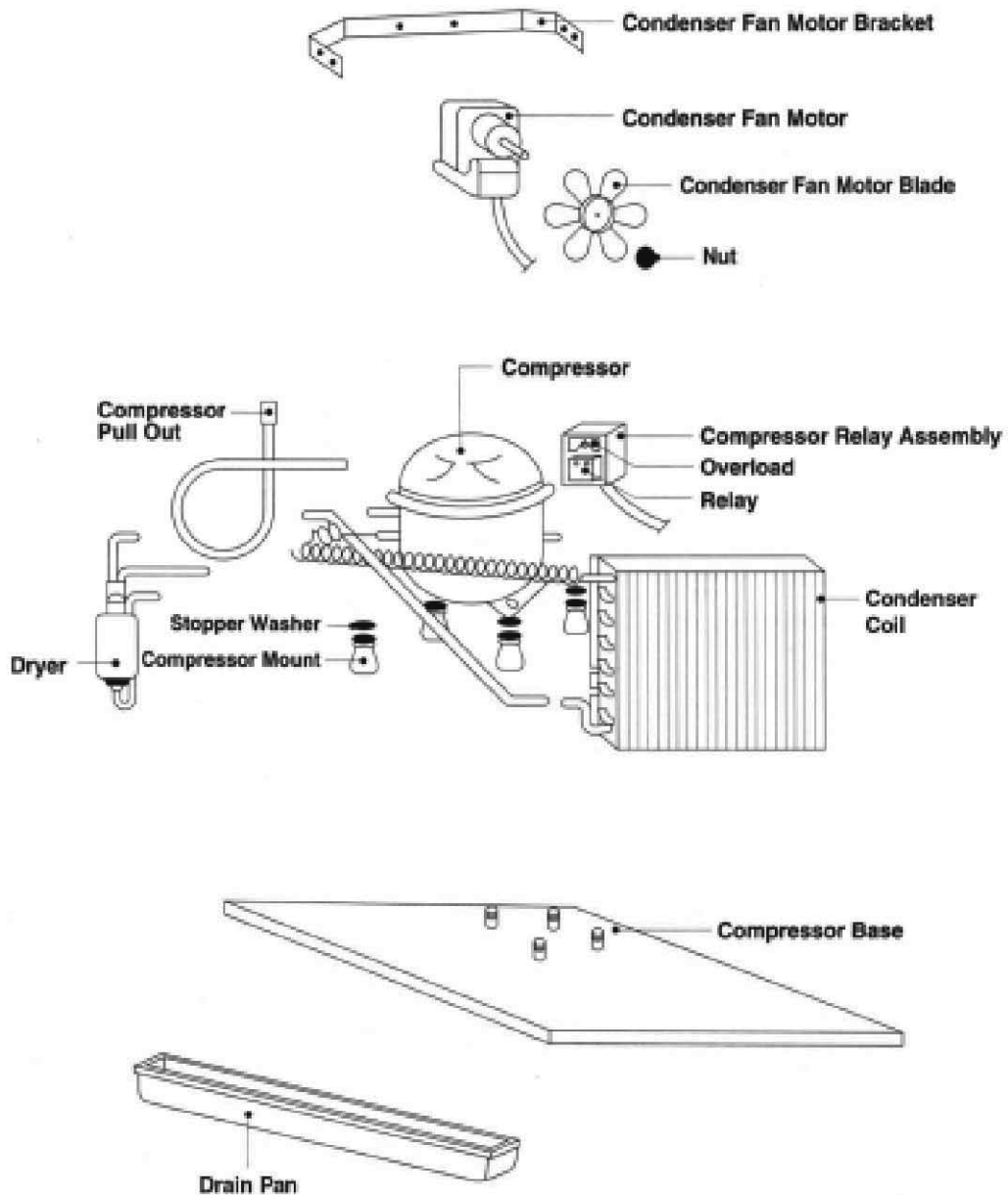

PARTS DIAGRAM

•Model : TGM-5R

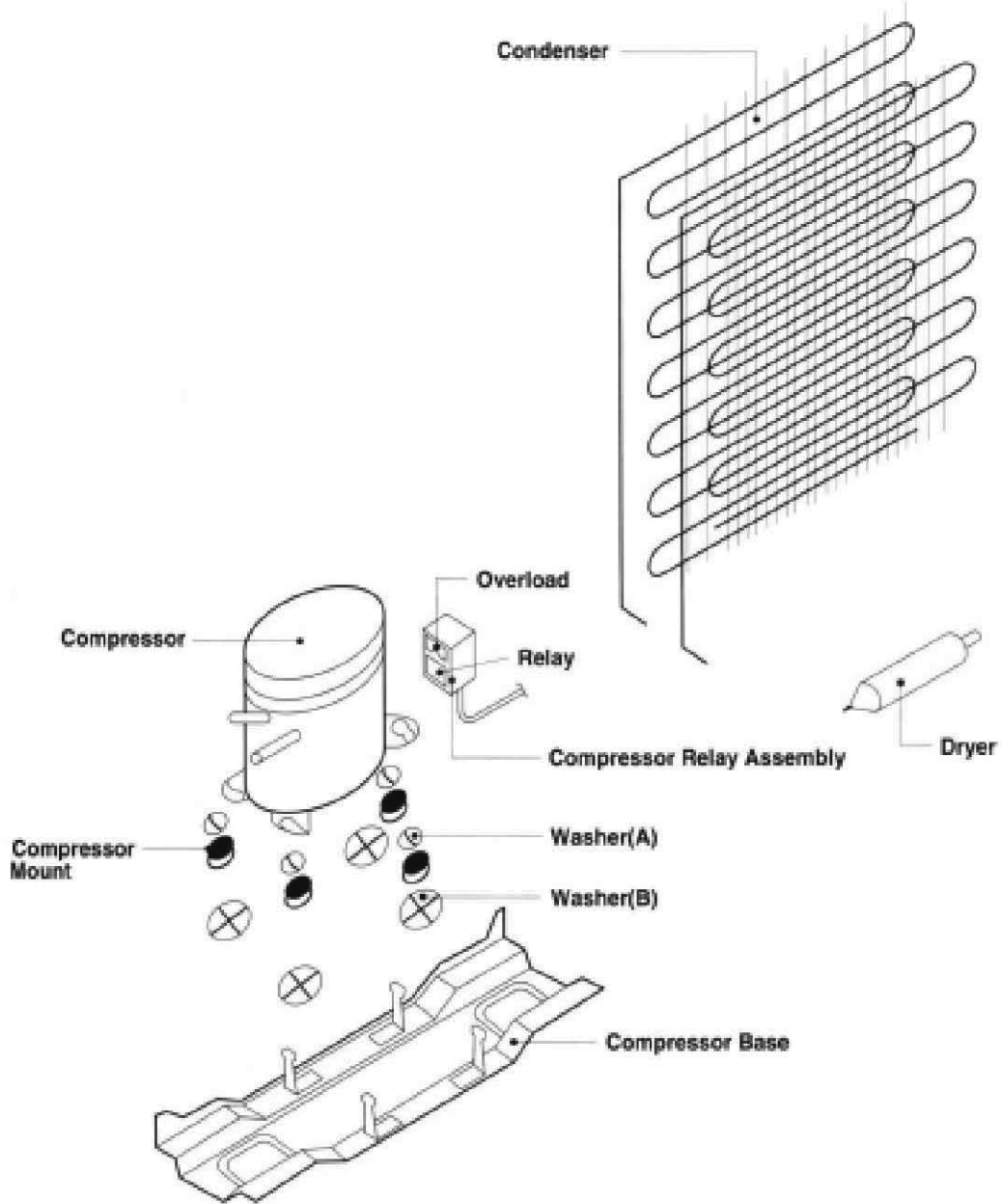

3. DOOR PARTS

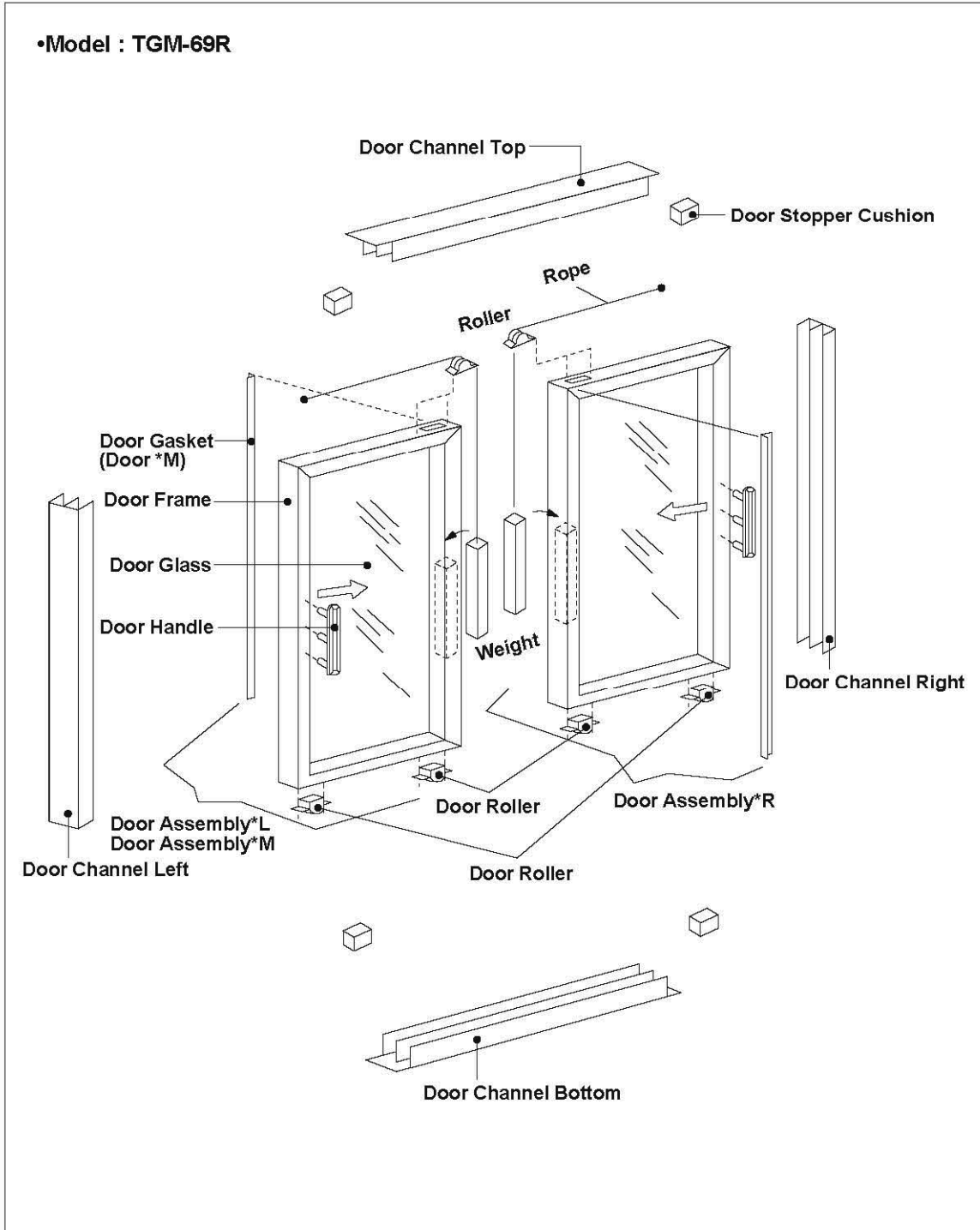

PARTS DIAGRAM

• Model : TGM-48R, 35R

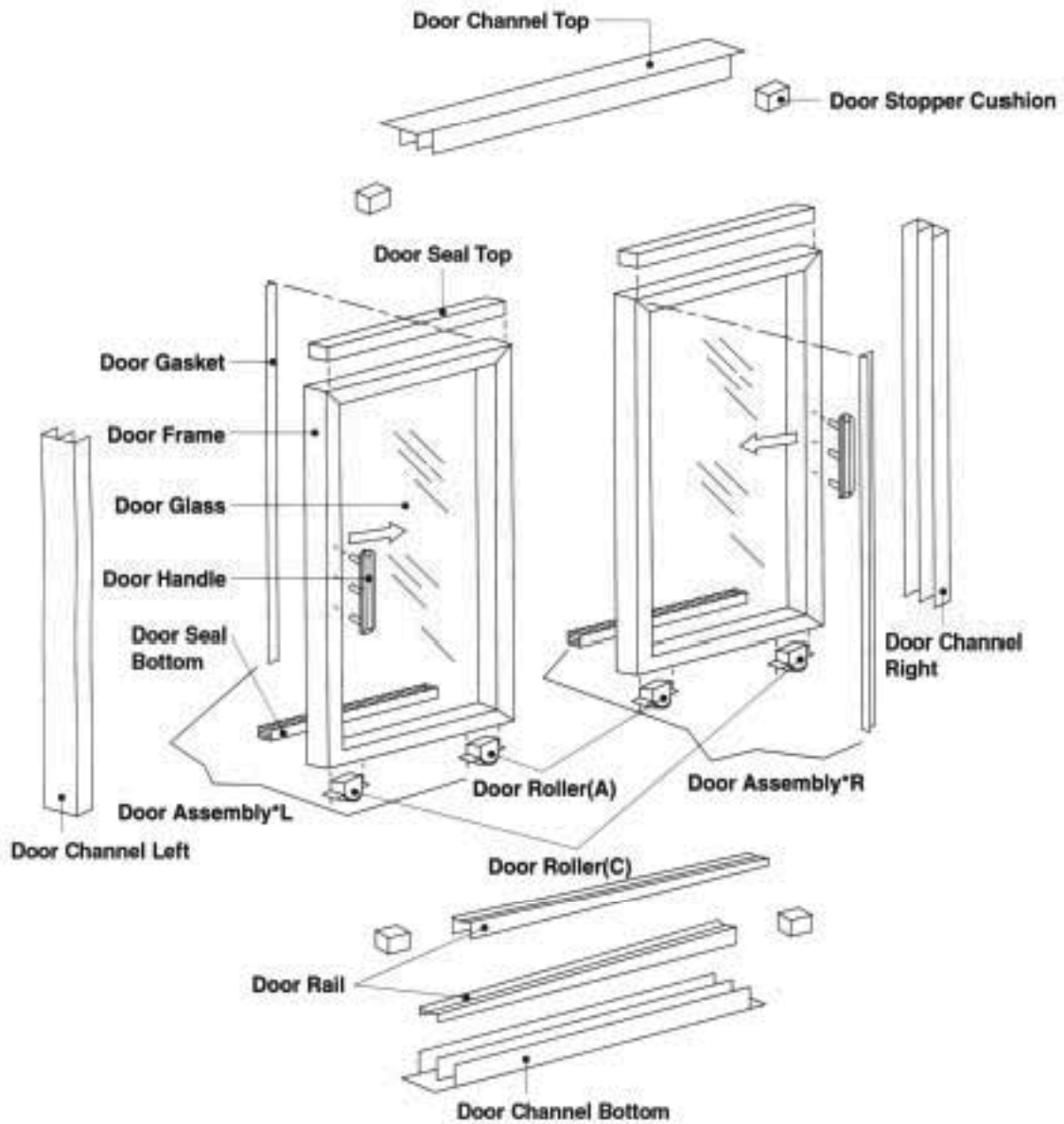

PARTS DIAGRAM

•Model : TGM-22R, 22RV, 14R, 14RV, 11R, 11RV

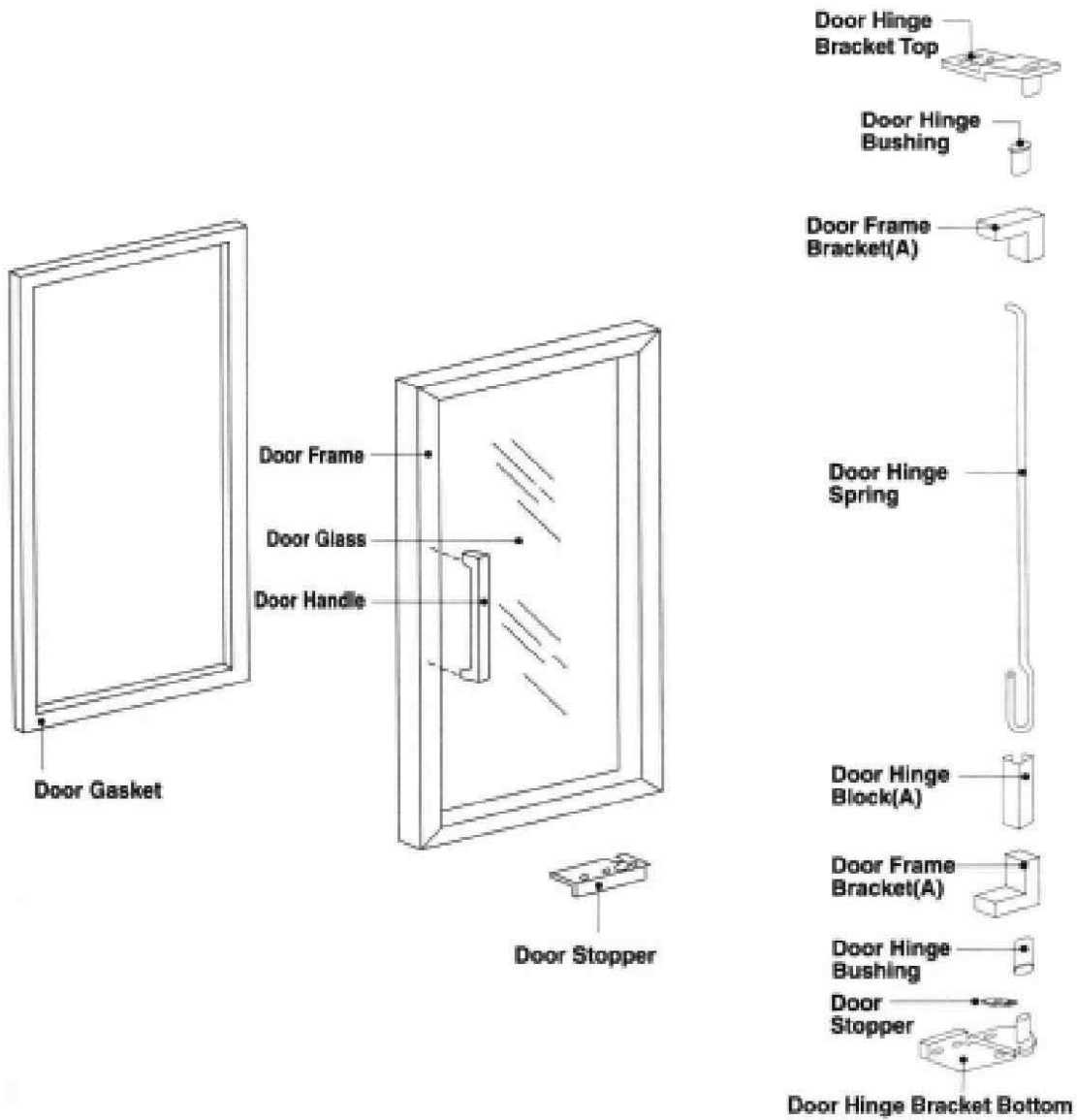

PARTS DIAGRAM

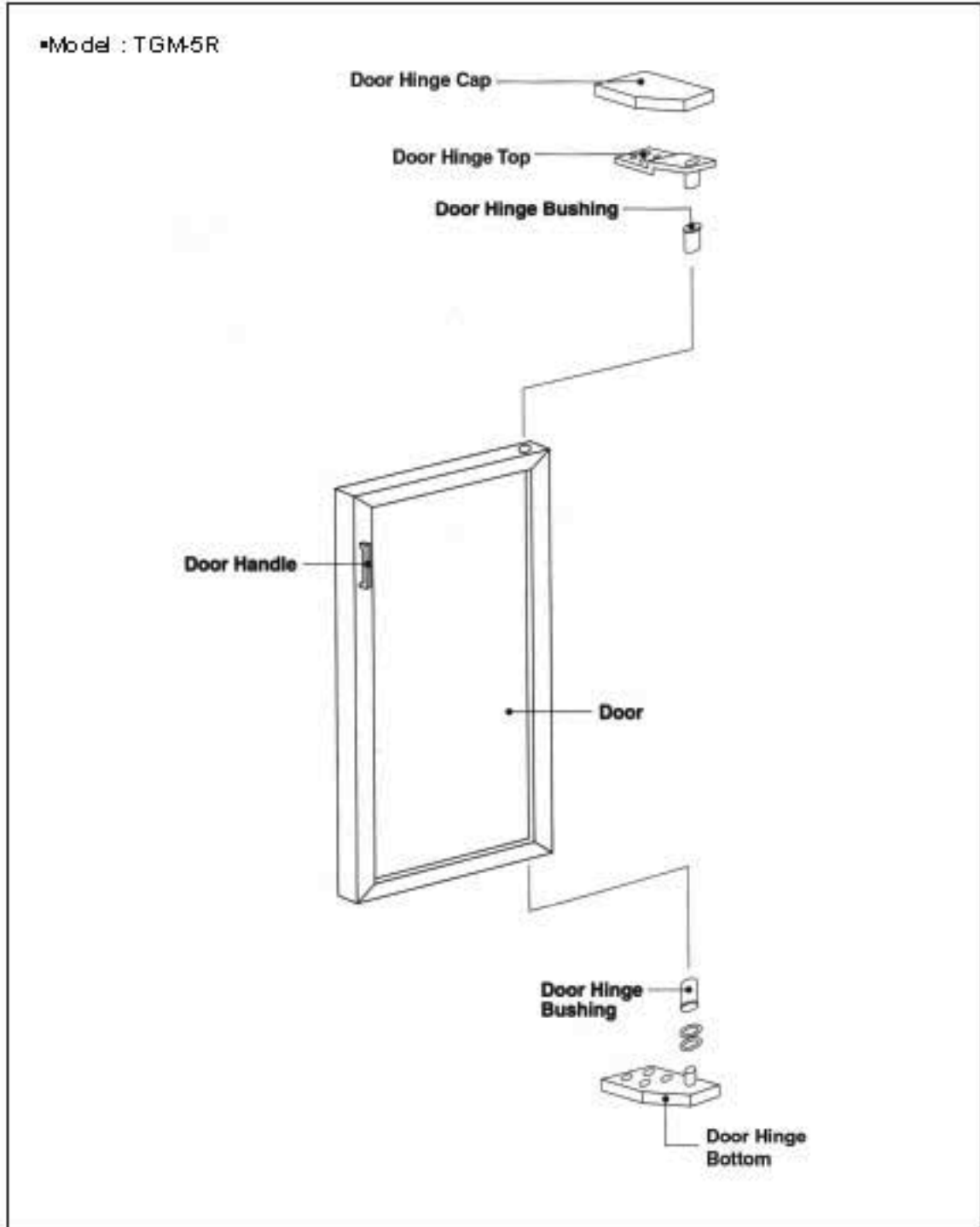

4. EVAPORATOR PARTS

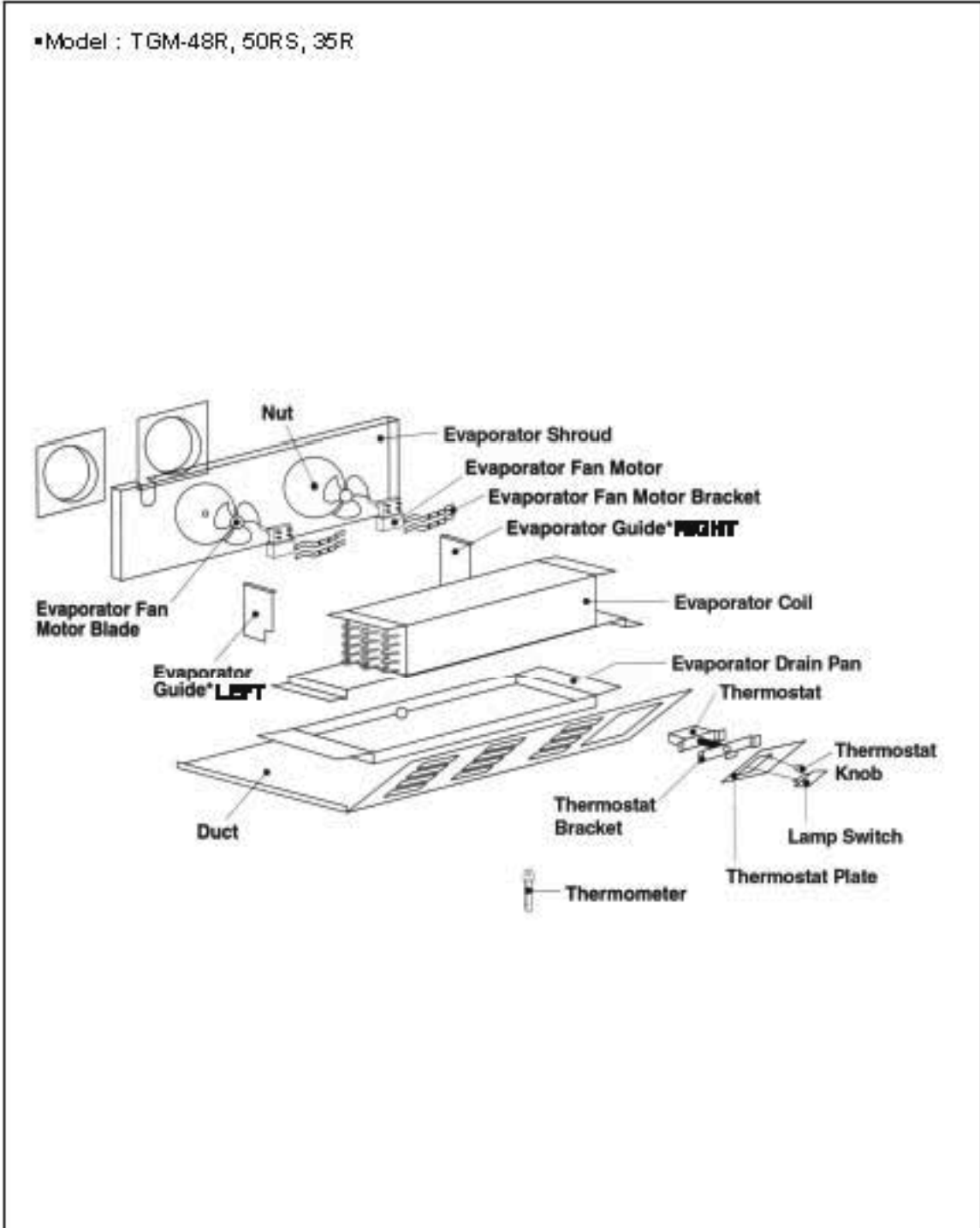

PARTS DIAGRAM

• Model : TGM-69R, 72RS,

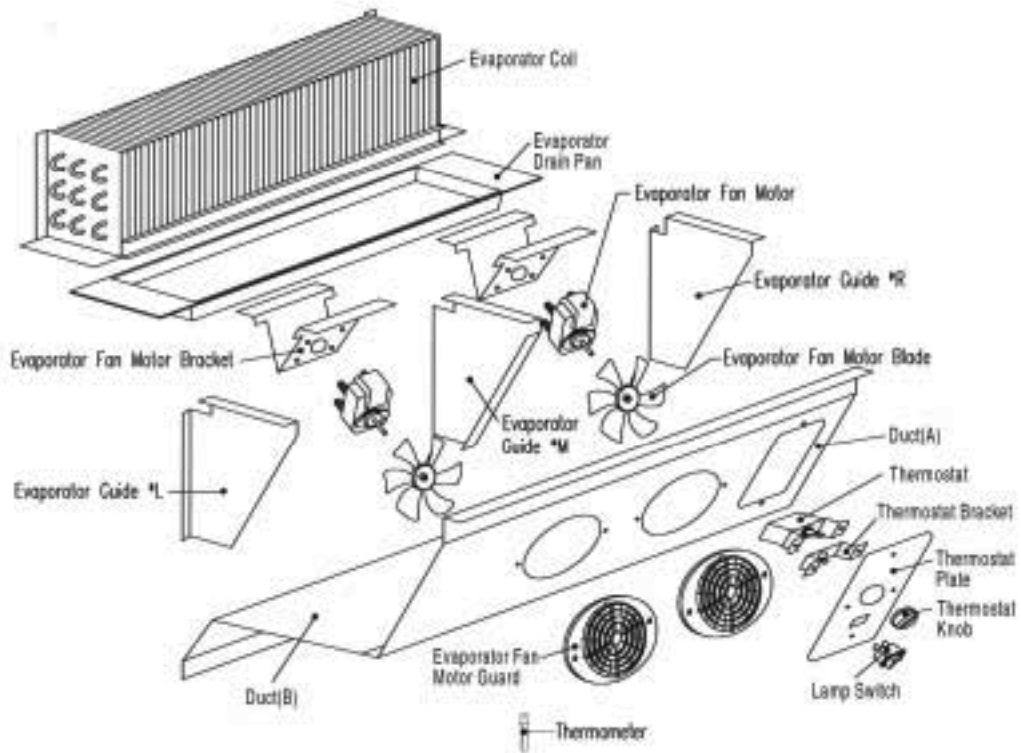

PARTS DIAGRAM

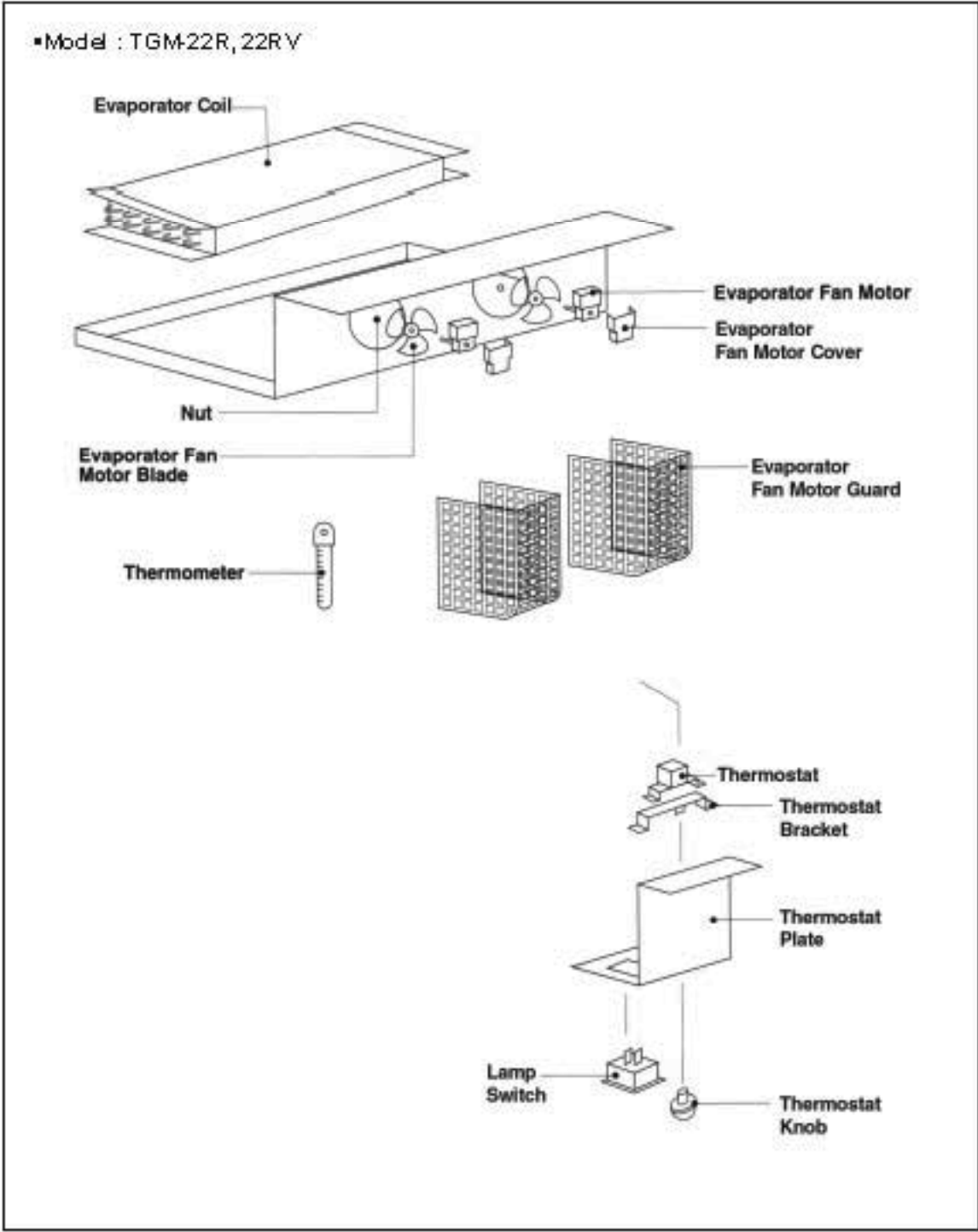

PARTS DIAGRAM

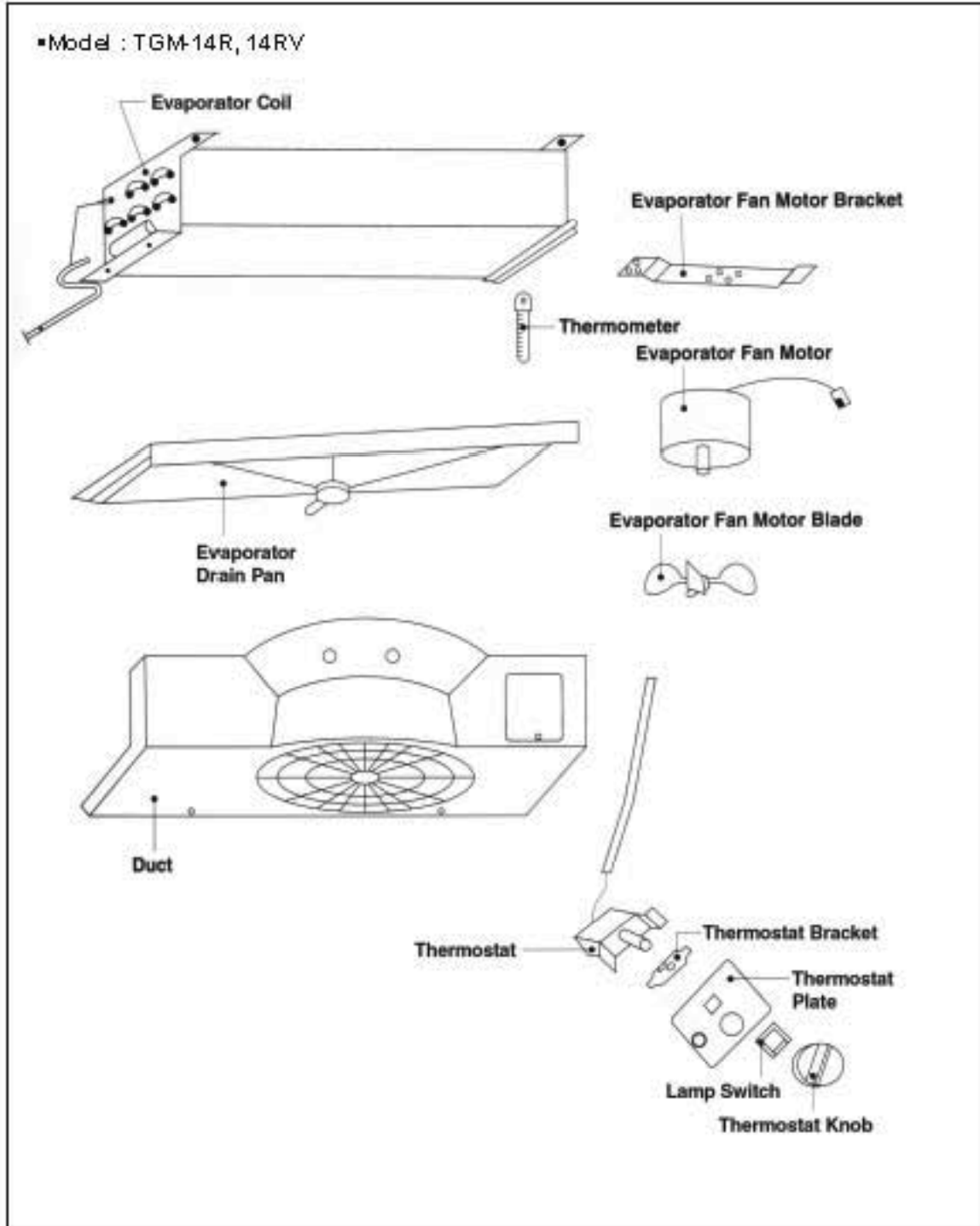

PARTS DIAGRAM

•Model : TGM-11R. 11RV

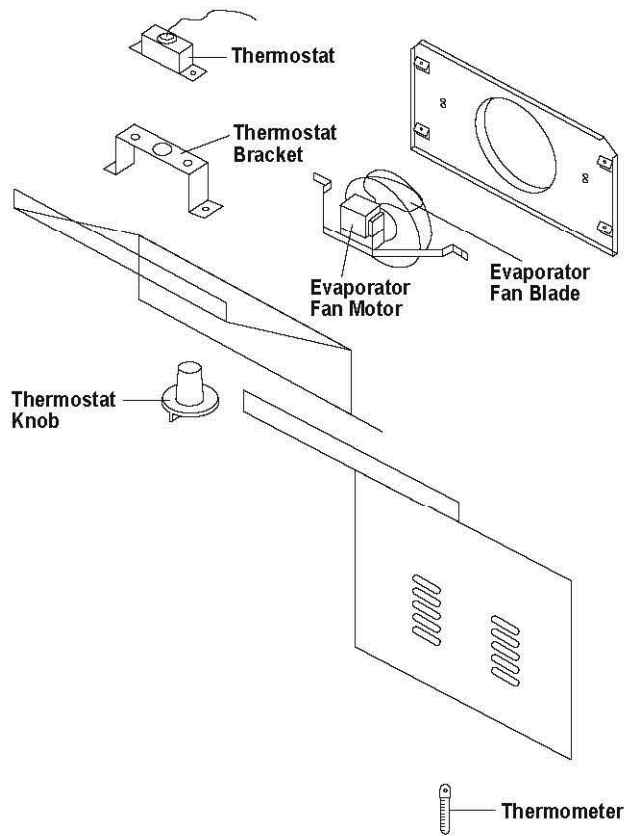

PARTS DIAGRAM

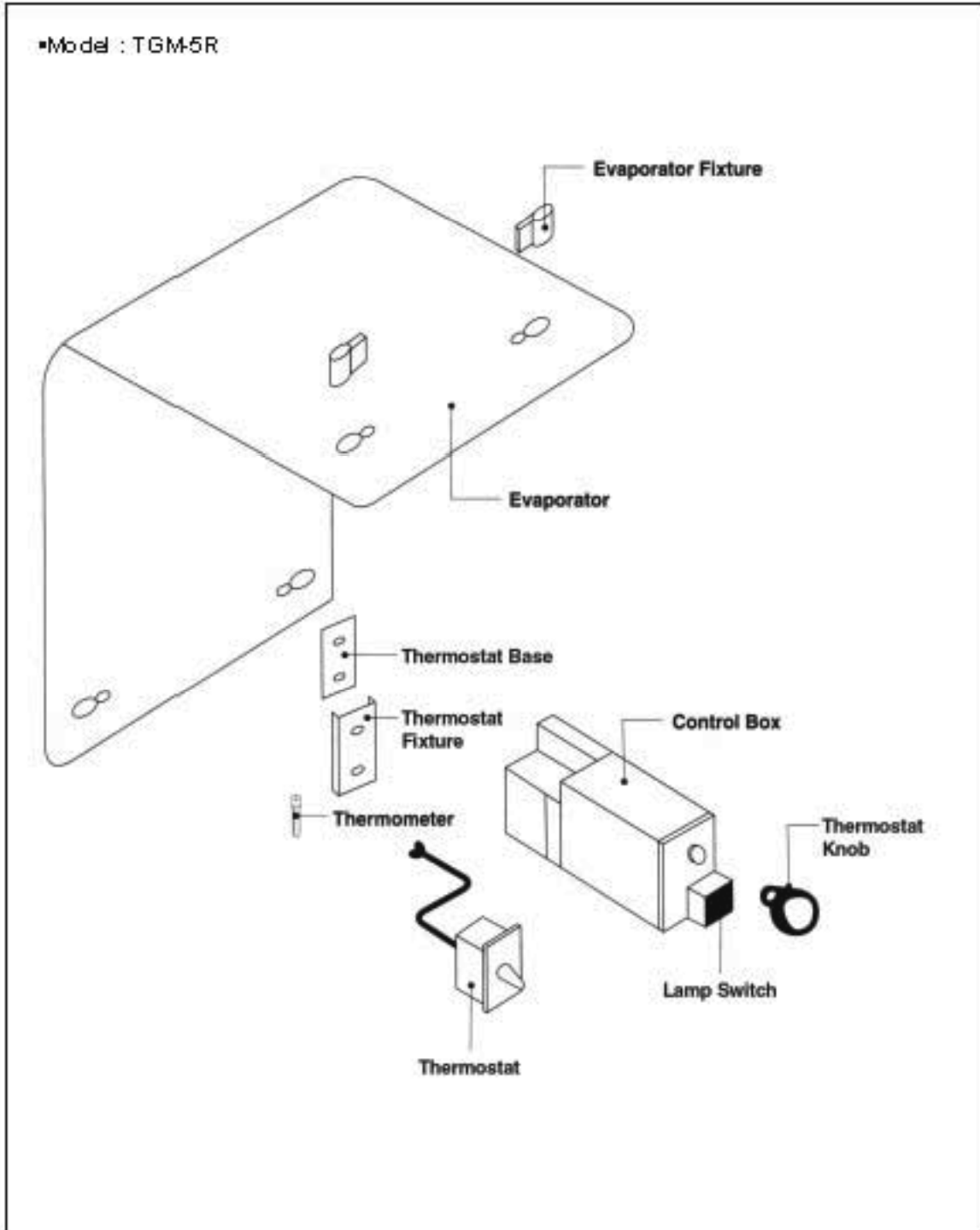

5. LIGHTING PARTS

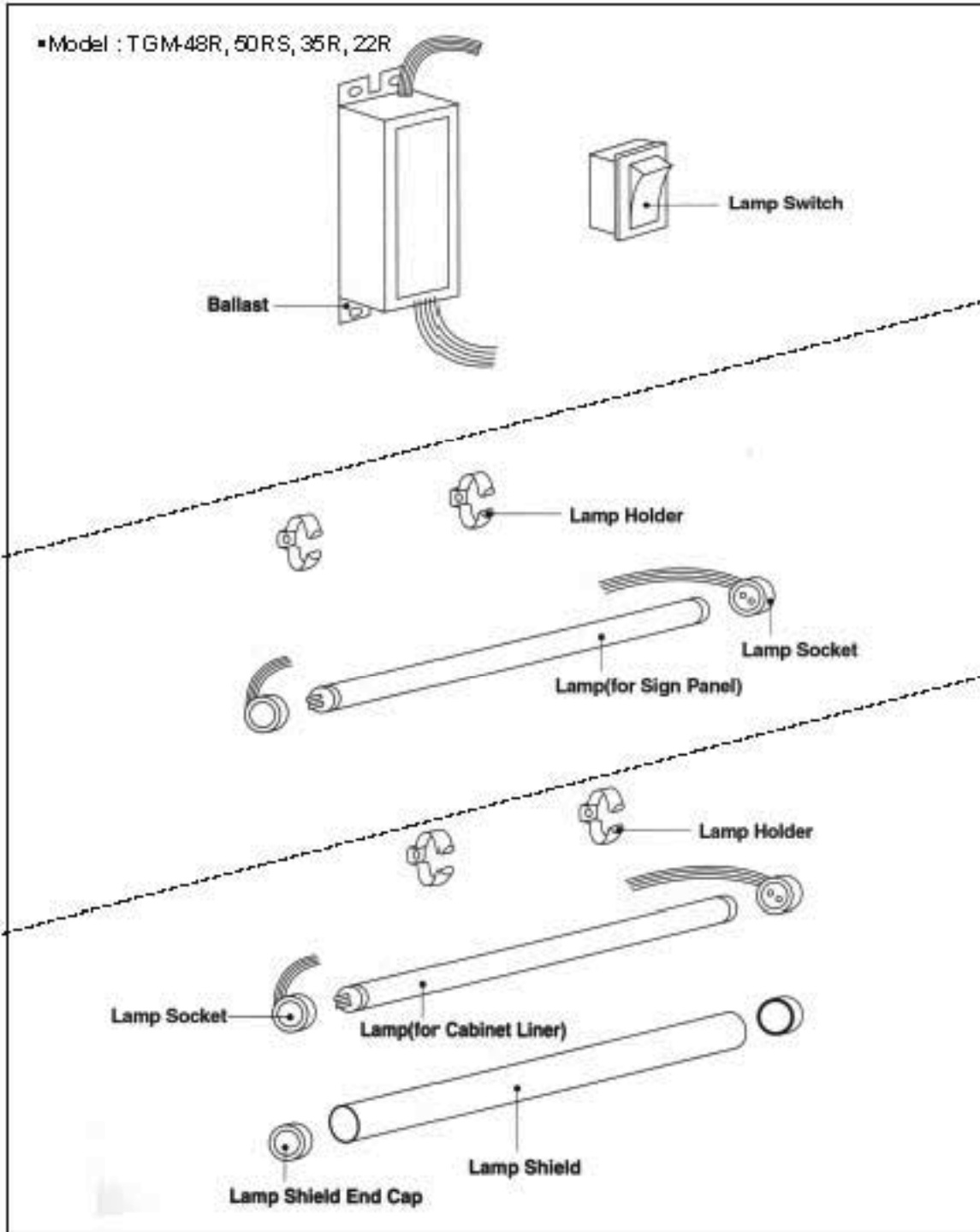

PARTS DIAGRAM

• Model : TGM-69R, 72RS,

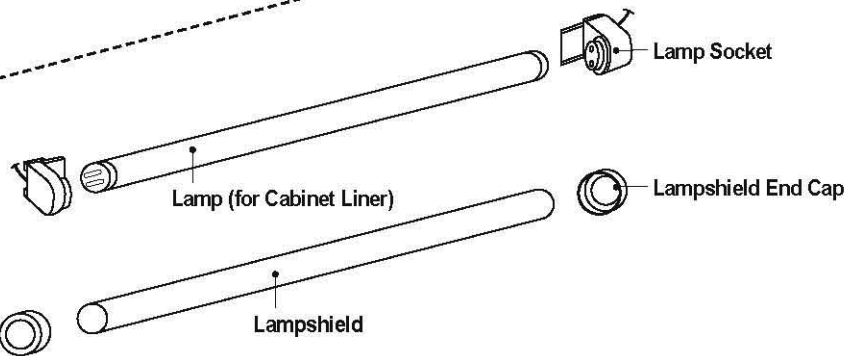
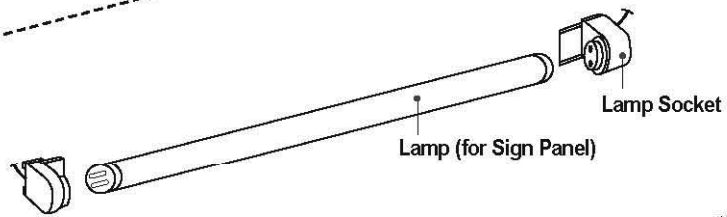
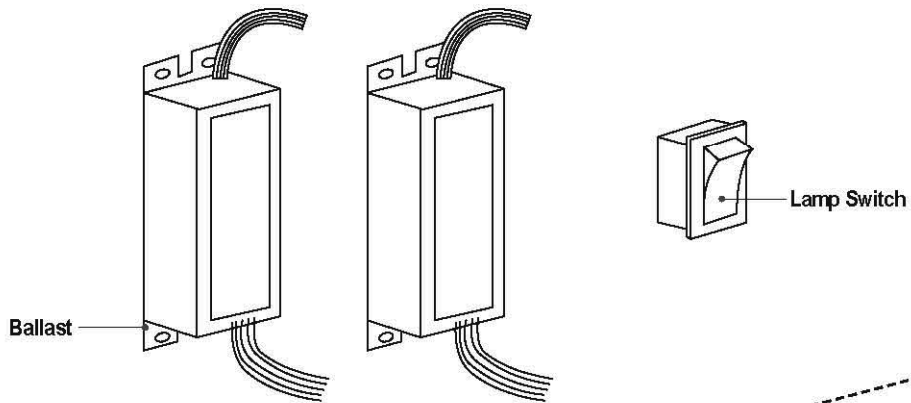

PARTS DIAGRAM

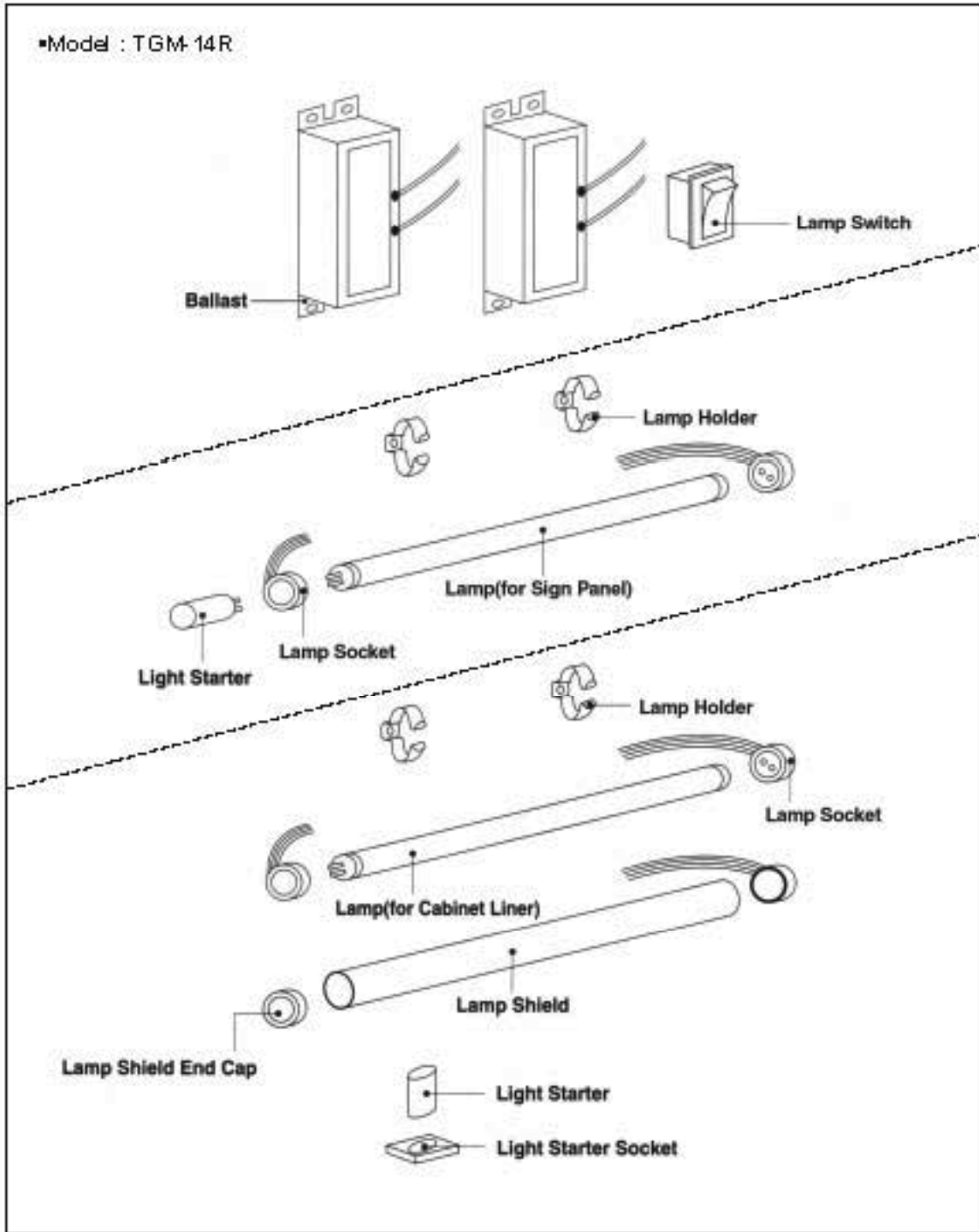

•Model : TGM-22RV, 14RV, 11RV

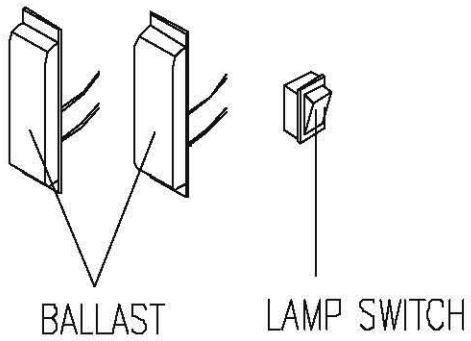

•Model : TGM-22RV, 14RV

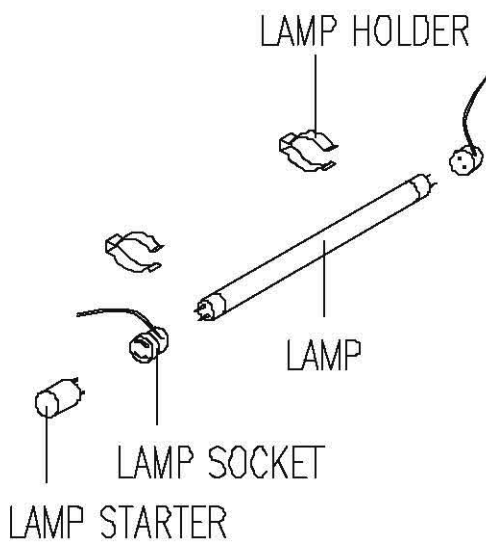

•Model : TGM-22RV, 14RV, 11RV

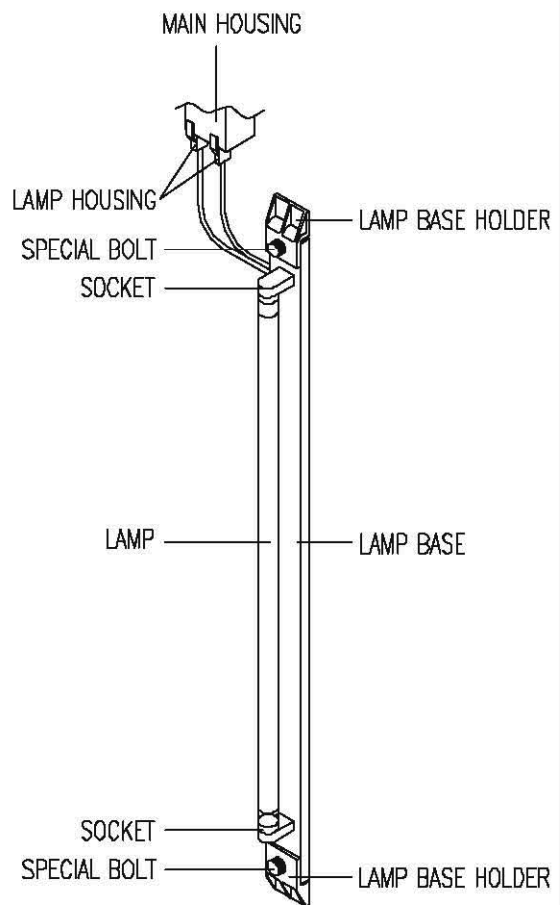

PARTS DIAGRAM

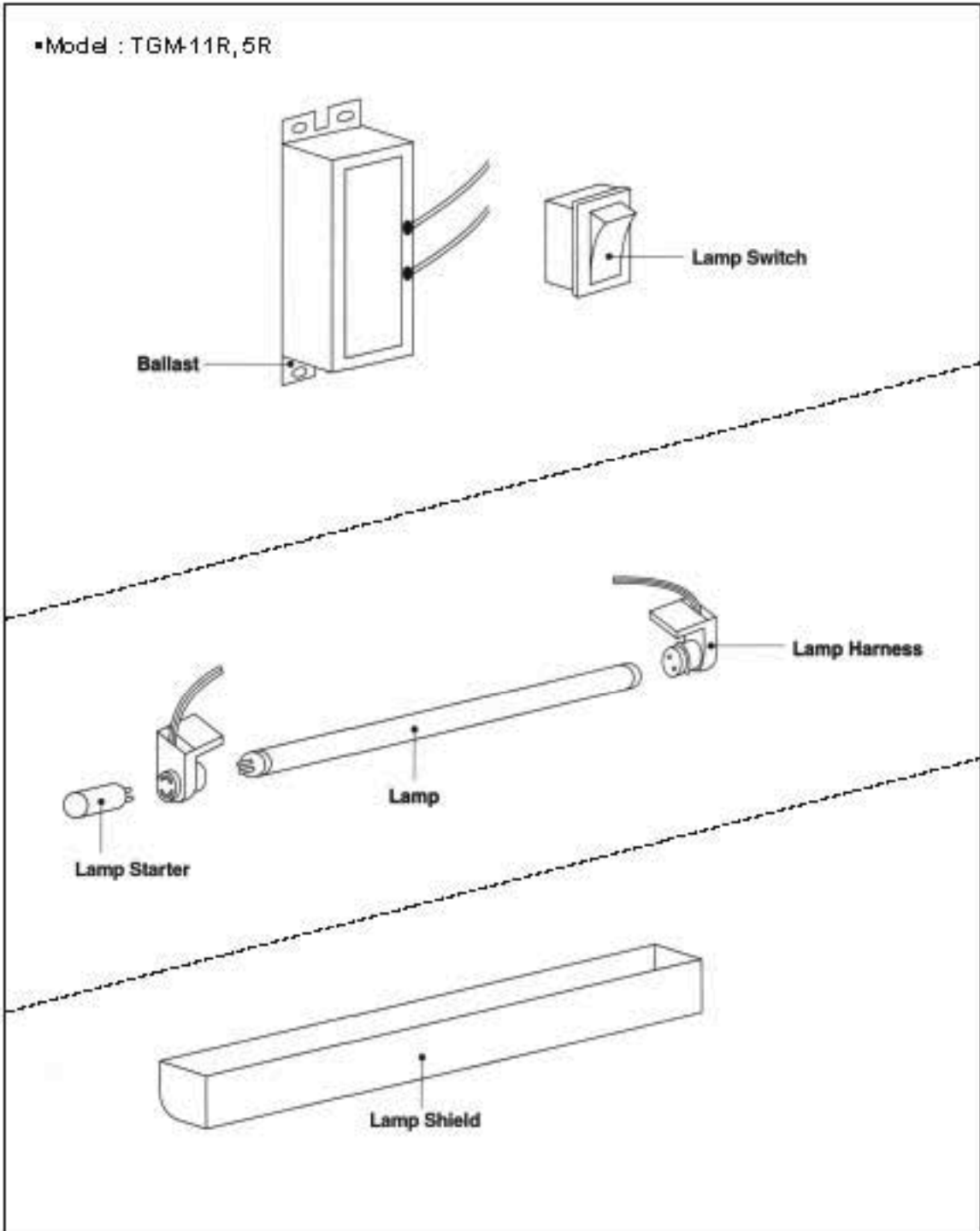

6. SHELF PARTS

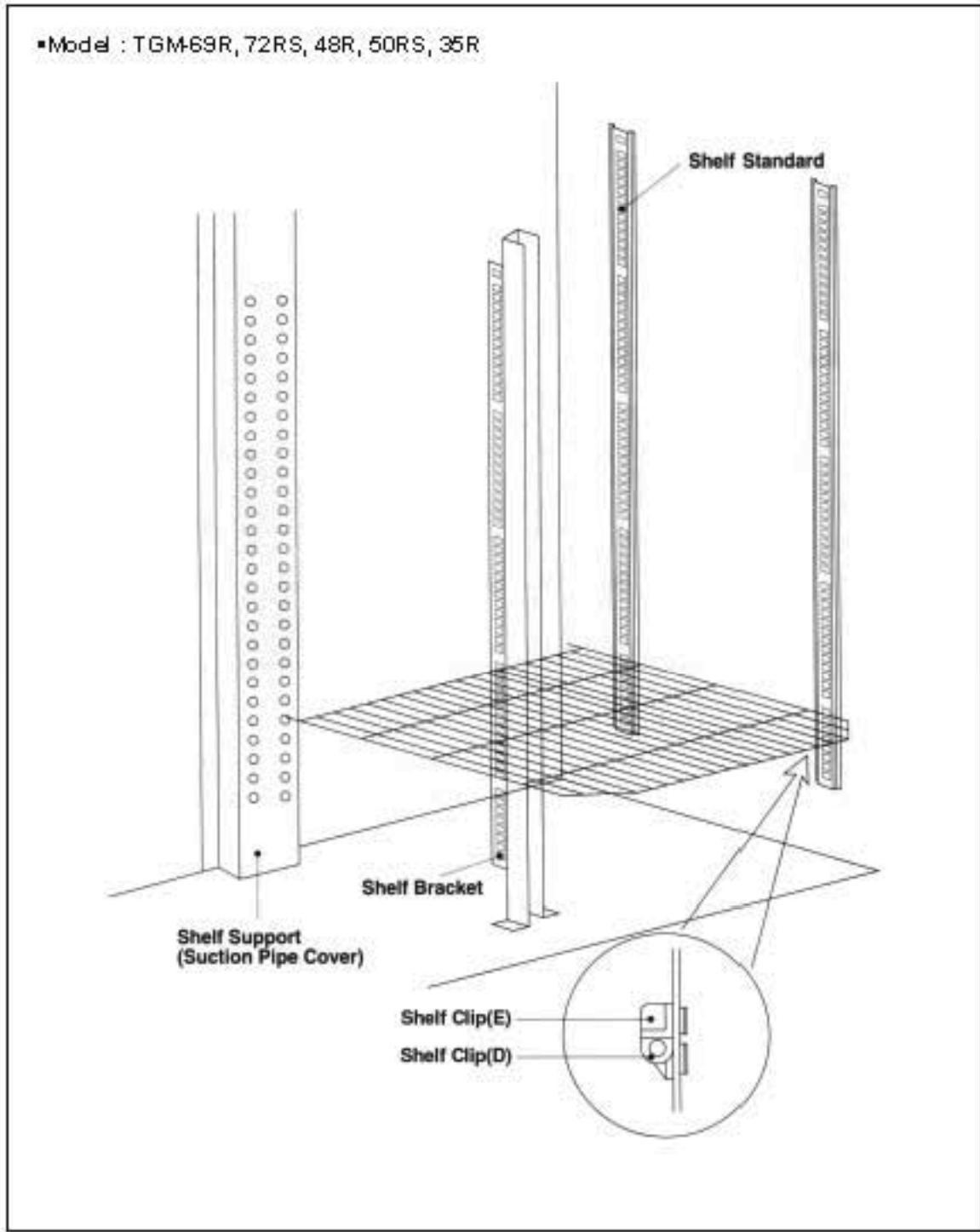

7. ADVERTISING & ADVERTISING FRAME PARTS

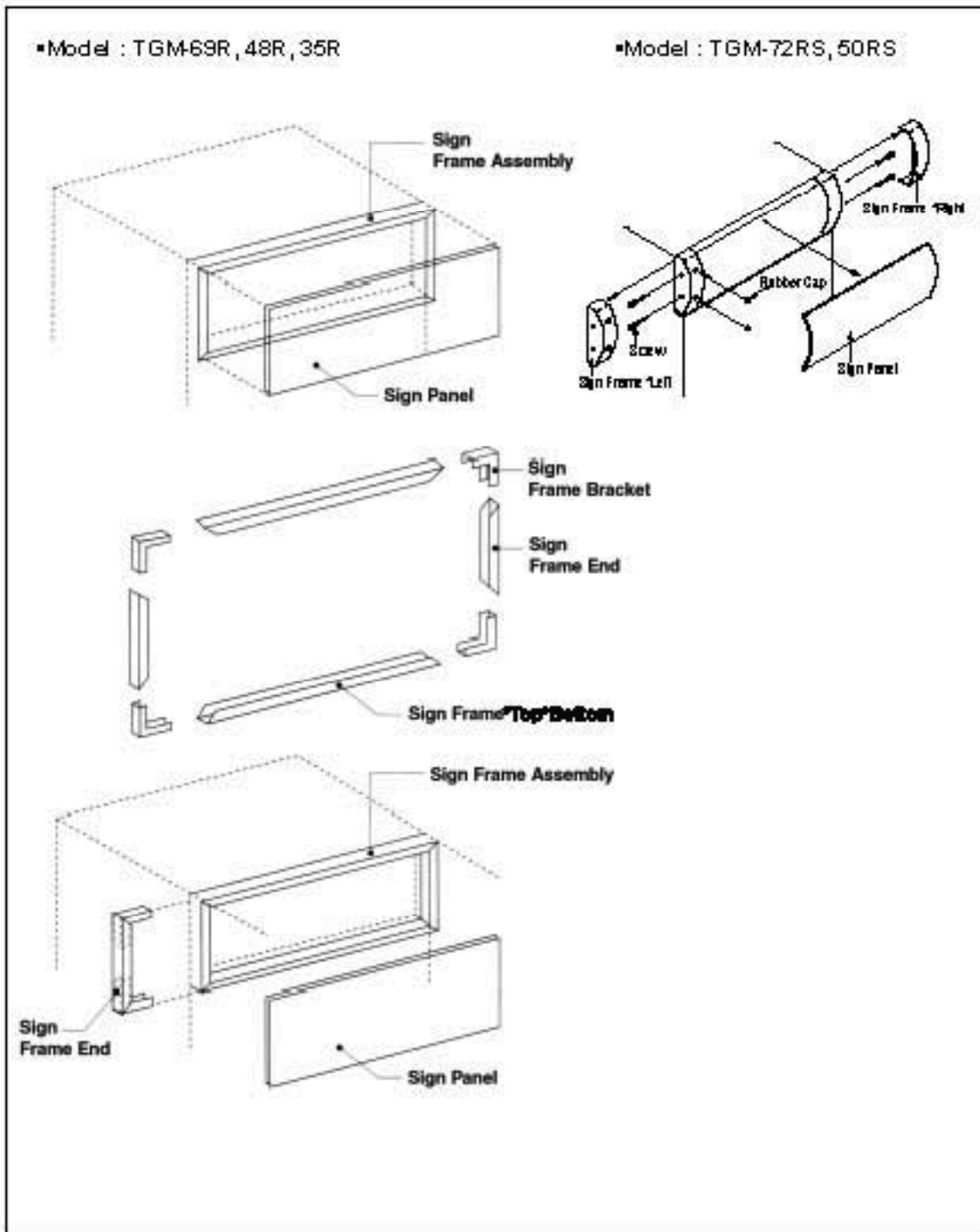

PARTS DIAGRAM

• Model : TGM-22R, 22RV, 14R, 14RV

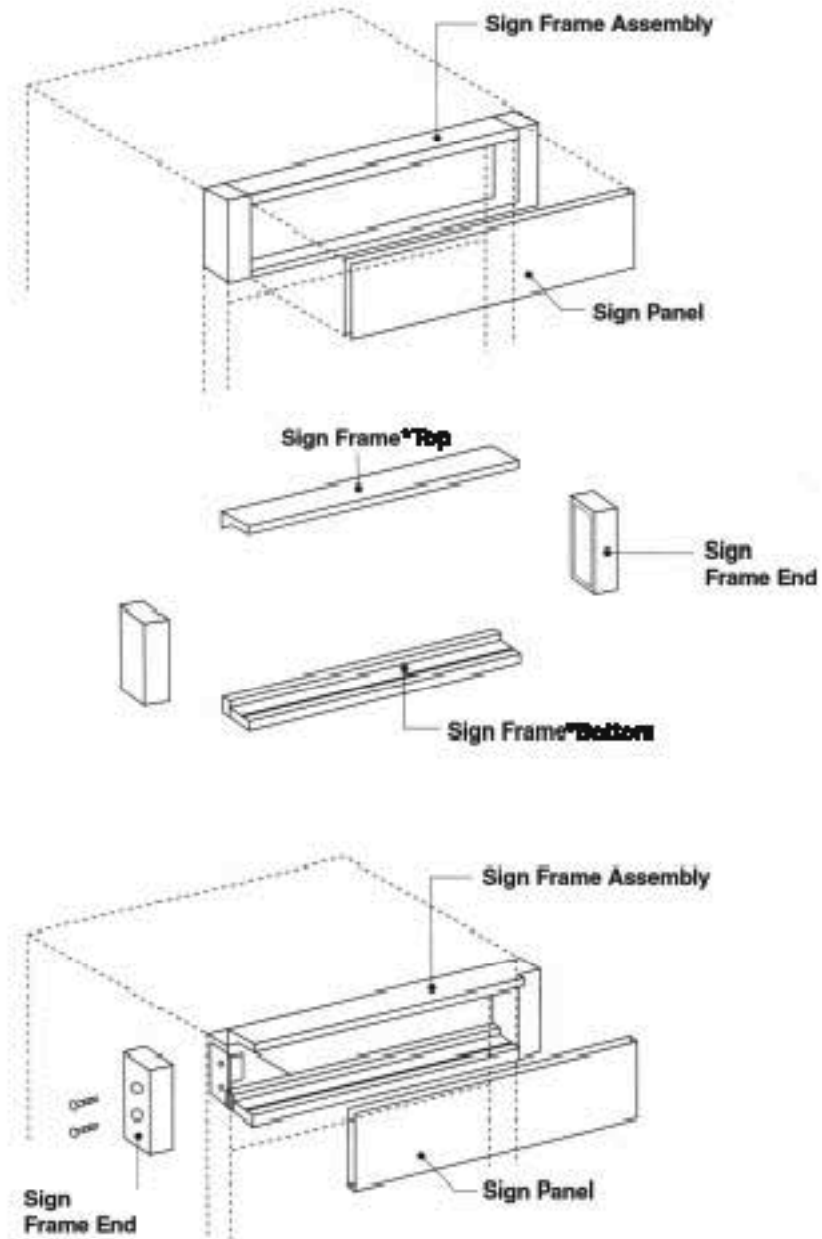

8. GRILL PARTS

• Model : TGM-69R, 48R, 35R

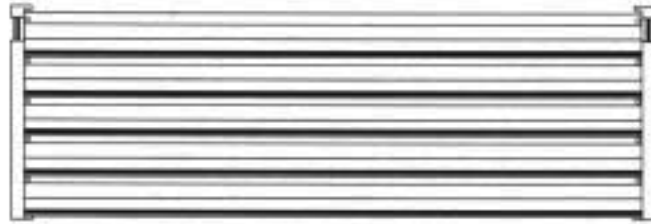

• Model : TGM-72RS, 50RS

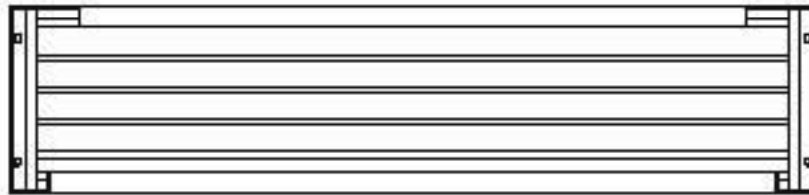

• Model : TGM-22R, 22RV

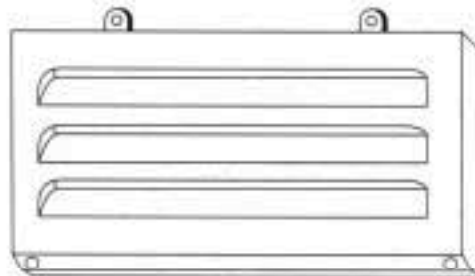

• Model : TGM-14R, 14RV, 11R, 11RV



6. PARTS LIST

Part name	Part Number	Description	Model						
			69	48	35	22	14	11	5
Castor & Leveling Legs									
Leveling Leg	30260K0100	1/2"	6	5	5	4			
Leveling Leg	3012101300	BLACK					2	2	
Leveling Leg	4006D32533	BLACK							2
Compressor									
Compressor	3020014570	T6217Z(EMBRACO)	1						
Compressor	30200A4710	CAJ4476Y(TECUMSEH)		1	1				
Compressor	3952127G10	HBL27YE-1(DAEWOO)				1	1	1	
Compressor	3953111E10	HFL11Y1-(DAEWOO)							1
Compressor Relay	3817906900	PTC 068				1	1	1	1
Compressor Relay Assembly	30227H0911	Including Harness				1			
Compressor Relay Assembly	30227F0911	Including Harness					1	1	
Compressor Relay Assembly	30200A6411	Including Harness							1
Compressor Overload	3817908600	4TM-783RHB				1			
Compressor Overload	3817910600	4TM-783SHB					1	1	
Compressor Overload	3817906500	4TM-293THB							1
Compressor Starting Capacitor	401RD35050	200V/100 μ F				1	1	1	
Compressor Running Capacitor	400E115130	230V/10 μ F				1	1	1	
Condenser	30200K3002	Refer Parts Diagram	1						
Condenser	30200A2203	Refer Parts Diagram		1	1				
Condenser	30200H1011	Refer Parts Diagram				1			
Condenser	30200F3802	Refer Parts Diagram					1		
Condenser	30200F0806	Refer Parts Diagram						1	
Condenser	30200A7206	Refer Parts Diagram							1
Condenser Fan Motor	3963220410	IS-4420DWSG-1	1	1	1				
Condenser Fan Motor	3963320410	IS-4420DWSR-1				1			
Condenser Fan Motor	3963326710	IS-3220DWSQ-2					1	1	
Condenser Fan Motor Blade	30218A0300	AL Φ 250	1	1	1				
Condenser Fan Motor Blade	30218B0200	AL Φ 225				1			
Condenser Fan Motor Blade	30218F0110	Zytel Φ 150					1	1	

PARTS LIST

Part name	Part Number	Description	Model						
			69	48	35	22	14	11	5
Dryer	30268Q0300	C-052-S(CATCH-ALL)	1	1	1				
Dryer	30268H0100	30g				1			
Dryer	30268F0403	30g					1	1	
Dryer	3016801300	10g							1
Power Cord	30213A1002	KKP-30B	1	1	1	1	1	1	1
POwer Cord Clamp	30212A0600	SPG	1	1	1	1	1	1	1
Drain Wicking Pad	30245A0700		1	1	1				
Drain Pan	32111J0100	HIPS	1	1	1				
Drain Pan	3021100001	HIPS				1	1	1	
Drain Wicking Bar	30230J0700	PVC-H	1	1	1				
Doors									
Brush Seal	30277A1301	Bottom		1	1				
Door Hinge Cap	4009G51041	PE Plastic White							1
Door Assembly *L	30217K0100	Glass, Slide, Left	1						
Door Assembly *M	30217K0300	Glass, Slide, Middle	1						
Door Assembly *R	30217K0200	Glass, Slide, Right	1						
Door Assembly *R	30217D0105	Glass, Slide, Right		1					
Door Assembly *L	30217D0206	Glass, Slide, Left		1					
Door Assembly *R	30217A0311	Glass, Slide, Right			1				
Door Assembly *L	30217A0301	Glass, Slide, Left			1				
Door Assembly	30217H0101	Glass, Swing				1			
Door Assembly	30217F0501	Glass, Swing					1		
Door Assembly	30217G0301	Glass, Swing						1	
Door Assembly	30200A8020	Glass, Swing							1
Door Gasket	30222A2001	Wiper Style	2	2	2				
Door Gasket	30223H0402	Magnetic				1			
Door Gasket	30223F0601	Magnetic					1		
Door Gasket	30223G0602	Magnetic						1	
Door Gasket	30223A9006	Magnetic							1

PARTS LIST

Part name	Part Number	Description	Model						
			69	48	35	22	14	11	5
Door Glass	30255K0100	T24	3						
Door Glass	30255D0110	T24		2					
Door Glass	30255A0110	T24			2				
Door Glass	30255H1100	T24				1			
Door Glass	30255F1300	T24					1		
Door Glass	30255G1100	T24						1	
Door Glass	30255A9011	T24							1
Door Handle	30226A0110	Slide ABS Plastic Black	3	2	2				
Door Handle	30226G0101	Swing Aluminum				1	1	1	
Door Handle	3022600300	Swing Aluminum							1
Door Hinge Bracket Top	30229H3000	Top				1	1	1	
Door Hinge Bracket Top	4004D51301	Top							1
Door Hinge Bracket Bottom	30229H2100	Bottom				1	1	1	
Door Hinge Bracket Bottom	30200B8703	Bottom							1
Door Hinge Bushing	3020700000	Nylon Top				1	1	1	
Door Hinge Bushing	30207H1000	Nylon Bottom				1	1	1	
Door Hinge Bushing	4005B45213	Nylon Top, Bottom							2
Door Hinge Spring	30251H0101	Torsion Style				1			
Door Hinge Spring	30251G0100	Torsion Style					1	1	
Door Hinge Spring	30252H1100	Stainless T1.5 Bottom				1	1	1	
Door Channel Top	30287D0103	PVC-H, Top		1					
Door Channel Top	30287A0306	PVC-H, Top			1				
Door Channel Bottom	30287D0203	PVC-H, Bottom		1					
Door Channel Bottom	30287A0406	PVC-H, Bottom			1				
Door Channel Left	30287A0603	PVC-H, Left		1	1				
Door Channel Right	30287A0703	PVC-H, Right		1	1				
Door Channel Top	30287K0301	PVC-H, Top	1						
Door Channel Bottom	30287K0401	PVC-H, Bottom	1						

PARTS LIST

Part name	Part Number	Description	Model						
			69	48	35	22	14	11	5
Door Channel Left	30287K0500	PVC-H, Left	1						
Door Channel Right	30287K0600	PVC-H, Right	1						
Door Rail(A)	30287K0100	Stainless	1						
Door Rail(B)	30287K0200	Stainless	1						
Door Rail	30287D0304	Stainless		1					
Door Rail	30287A0504	Stainless			1				
Door Roller	30206A1410			1	1				
Door Roller	30206D0310			1	1				
Door Roller	30247K0200	Tok DU-22-H	1						
Door Sealer Top	30277D0242	Top		1					
Door Sealer Top	30277A0232	Top			1				
Door Stopper	30252H1000	Stainless T3.0 Bottom				1			
Door Stopper	30252F0100	Stainless T2.0 Bottom					1	1	
Door Stopper Cushion	30252K0200	Rubber Blocks	1						
Door Stopper Cushion	30252A0200	Rubber Blocks		1	1				
EVAPORATOR									
Control Box	30205A9030	HIPS							1
Evaporator Drain Pan	30211Q0100	AL	1						
Evaporator Drain Pan	30211A0101	HIPS		1	1				
Evaporator Drain Pan	30211F0201	HIPS					1		
Evaporator Drain Pan	4017J54111	HIPS							1
Evaporator Coil	30270Q0110	FIN-TUBE(AL+Cu)	1						
Evaporator Coil	30270A1105	FIN-TUBE(AL+Cu)		1	1				
Evaporator Coil	30270H0101	FIN-TUBE(AL)				1			
Evaporator Coil	30270F0305	FIN-TUBE(AL+Cu)					1		
Evaporator Coil	30270G0102	FIN-TUBE(AL)						1	
Evaporator Coil	30200A8105	ROOL-BOND(AL)							1

PARTS LIST

Part name	Part Number	Description	Model						
			69	48	35	22	14	11	5
Evaporator Fan Motor	3963328120	IS-4420DWSN-2A	2						
Evaporator Fan Motor	3963220502	IS-3220DWSF		2	2				
Evaporator Fan Motor	3963328610	IS-3210DWSN-2				2			
Evaporator Fan Motor	3963328110	IS-4420DWSN-2					1		
Evaporator Fan Motor	3963328620	IS-3210DWSB-3						1	
Evaporator Fan Motor Blade	30218F0200	AL Φ 175	2				1		
Evaporator Fan Motor Blade	4034L38038	Zytel Φ 150		2	2				
Evaporator Fan Motor Blade	3011802300	ABS Φ 110				2		1	
Evaporator Fixture	30220A9000	PA-6							1
Evaporator Fan Motor Guard	30214H0103	ABS				1			
Evaporator Fan Motor Guard	30214K0100	HIPS	1						
Lamp Switch	30281Q0101	125V/15A	1	1	1	1	1	1	1
Thermometer	30283G0410	MILJOKO	1	1	1	1	1	1	1
Thermostat	30283K0110	K55-Q5606(RANCO)	1						
Thermostat	30283K0100	K55-Q5605(RANCO)		1					
Thermostat	30283D0700	K55-Q5602(RANCO)			1				
Thermostat	30283F0800	GNA-240L-4(SHIN-HAN)				1	1	1	
Thermostat	3018301001	PFN-110U-02D, GNF-110U-02D							1
Thermostat Bracket	30220A1410	SPG, Refer Parts Diagram	1	1	1	1		1	
Thermostat Bracket	30206F1000	SPG, Refer Parts Diagram					1		
Thermostat Knob	30234A1000	HIPS	1	1	1	1	1	1	
Thermostat Knob	40006D70026	HIPS							1
Thermostat Plate	30245K0100	EGI 0.6	1						
Thermostat Plate	30206A0200	EGI Painting		1	1				
Thermostat Plate	30206H0107	EGI Painting				1			
Thermostat Plate	30242F0802	HIPS					1		

PARTS LIST

Part name	Part Number	Description	Model						
			69	48	35	22	14	11	5
Grills									
Bottom Grill Assembly	30224K0100	Ass'y Grill	1						
Bottom Grill Assembly	30200D5500	Ass'y Front Painted		1					
Bottom Grill Assembly	30200A5500	Ass'y Front Painted			1				
Bottom Grill Assembly	30224H0103	Front ABS BLACK				1			
Bottom Grill Assembly	30224F0104	Front ABS BLACK					1	1	
Lightings (Refer to the main components for Ballast)									
Ballast	-	B232I120RH-A	2	1	1	1			
Ballast	30200A0141	DD2B					2	1	1
Lamp	30236D0511	TLD32W/865(32WATT)	4	2	1				
Lamp	30236A0510	F25T8/SP41/ECO(25WATT)			1				
Lamp	30236H0510	F17T8/SP41/ECO(17WATT)				2			
Lamp	30236F0510	F13T8/CW(13WATT)					2	1	1
Lamp Shield	30222A0900	PC, t0.5	2	1	1				
Lamp Shield	30211H0000	PC, t0.5				1			
Lamp Shield	30211F0000	PC, t0.5					1		
Lamp Shield	30214F0701	ACRYL						1	
Lamp Shield	30214A0010	ACRYL							1
Lamp Holder	3183005000	SK-50D28		2	2	2	2		
Lighter Starter	30236A0700	FS-2							1
Lamp Switch	30281Q0101	125V/15A	1	1	1	1	1	1	1
Shelves									
Shelf	30278K0100	Wire, White	9						
Shelf	30278D0212	Wire, White		6					
Shelf	30278A0210	Wire, White			6				
Shelf	30278H0103	Wire, White				4			

PARTS LIST

Part name	Part Number	Description	Model						
			69	48	35	22	14	11	5
Shelf(A)	30278F0112	Wire, White TOP					3		
Shelf(B)	30278F0211	Wire, White BOTTOM					1		
Shelf(A)	30278G0111	Wire, White TOP						3	
Shelf(B)	30278G0401	Wire, White BOTTOM						1	
Shelf(T)	30278A9401	Wire, White TOP							1
Shelf(M)	30278A9150	Wire, White MIDDLE							1
Shelf(B)	30278A9000	Wire, White BOTTOM							1
Shelf Bracket	30220A0200	Front Center White	2	1	1				
Shelf Clip((E)	30200A0700	PP TOP	36	24	24				
Shelf Clip((D)	30220A0600	Nylon, Bottom	36	24	24				
Shelf Standard	302000703	Sides Cabinet White	4	4	4				
Shelf Support	30253A0500	Back Center white	2	1	1				
Sign Frame									
Sign Frame *T*B	30222K0901	PVC-H	1						
Sign Frame *T*B	30222D0502	PVC-H		1					
Sign Frame *T*B	30222A0801	PVC-H			1				
Sign Frame End	30222A0901	PVC-H	1	1	1				
Sign Frame *T*B	30222H0313	PVC-H				1			
Sign Frame *T*B	30222F1912	PVC-H					1		
Sign Frame End	30222F2103	ABA Dark Gray				1	1		
Sign Frame Bracket	30220A0900	Aluminum	1	1	1				
Sign Panel	30214K140P	PC, t1.5	1						
Sign Panel	30214D2001	PC, t1.5		1					
Sign Panel	30214A121H	PC, t1.5			1				
Sign Panel	30214H011P	PC, t3.0				1			
Sign Panel	30242F0101	PC, t3.0					1		

PARTS LIST

Part name	Part Number	Description	Model				
			11RV	14RV	14CRV	22RV	22CRV
Lighting (Refer to the main components for Ballast)							
Ballast	-	B232I120RH-A	1	1	1	1	1
Ballast	30200A0141	DD2B		1	1		
Lamp	30236D0511	TLD32W/865(32WATT)				1	1
Lamp	30236A0510	F25T8/SP41/ECO(25WATT)	1	1	1		
Lamp	30236H0510	F17T8/SP41/ECO(17WATT)				1	1
Lamp	30236F0510	F13T8/CW(13WATT)		1	1		
Lamp Shield	30211K0200	PC, T0.5				1	1
Lamp Shield	30211F0400	PC, T0.5	1	1	1		
Shelves							
Shelf(A)	30278G0701	Wire, White, Top	3				
Shelf(B)	30278G0401	Wire, White, Bottom	1				
Shelf(A)	30278F0302	Wire, White, Top		3	3		
Shelf(B)	30278F0211	Wire, White, Bottom		1	1		
Shelf	30278H0400	Wire, White				4	4

** Other parts are the same parts as TGM-11R, TGM-14R, TGM-22R

PARTS LIST

Part name	Part Number	Description	Model	
			50RS	72RS
Compressor Compartment				
Grill Assembly	30200S2300	ABS + Painted Steel	1	
Grill Assembly	30200S3300	ABS + Painted Steel		1
Grill Cap	30209S0300	Silicone, Φ14	4	4
Refrigeration Compartment				
Thermostat	30283D0700	K55-Q5602(RANCO)	1	1
Refrigeration Compartment				
Door Assembly Left	30200S2500	Frame +Glass + Handle	1	
Door Assembly Right	30200S2400	Frame +Glass + Handle	1	
Door Assembly Left	30200S3600	Frame +Glass + Handle		1
Door Assembly Right	30200S3500	Frame +Glass + Handle		2
Door Glass	30255S0100	1319*636.5*24	2	
Door Glass	30255S0200	1319*586*25		2
Door Handle	30226G0101	Zn Dycasting, Cr Coating	2	3
Door Hinge Spring	30251H0101	Torsion Style	2	3
Door Hinge Bushing Top	3020700000	Nylon	2	3
Door Hinge Bushing Bottom	30207H1010	Nylon	2	3
Door Hinge Top Left	30229A0100	T=3.0mm	1	1
Door Hinge Top Right	30229A0200	T=3.0mm	1	2
Door Hinge Bottom Left	30229H2200	T=5.0mm	1	1
Door Hinge Bottom Right	30229H2103	T=5.0mm	1	2
Door Gasket	30223S0200	PVC-S, 660*1336	2	
Door Gasket	30223S0300	PVC-S, 610*1336		3
Mullion	30253D0203	Painted Steel, U-type Shaped	1	
Mullion	30253D0211	Painted Steel, U-type Shaped		2
Mullion Cover(A)	30253S0200	PVC-H	1	2
Mullion Cover(B)	30214S070P	Painted Steel, Gasket Contacted	1	2
Mullion Lamp Socket	30200S1000	JS-212, JS-213	1	2
Sign Frame				
Sign Frame Left	30222A2500	ABS	1	1
Sign Frame Right	30222A2400	ABS	1	1
Sign Panel	30242S0600	PC	1	
Sign Panel	30242S0610	PC		1
Sign Frame Cap	30209S0300	Silicone, Φ15	2	2

** Other parts Of TGM-72RS are the same parts as TGM-69R

** Other parts Of TGM-50RS are the same parts as TGM-48R

7. REPLACEMENT OF MAIN COMPONENTS

1-1). LAMP FOR ADVERTISING PANEL

(TGM-69R,48R,35R)



1. Separate the Sign Frame End.



2. Separate the Sign Panel.

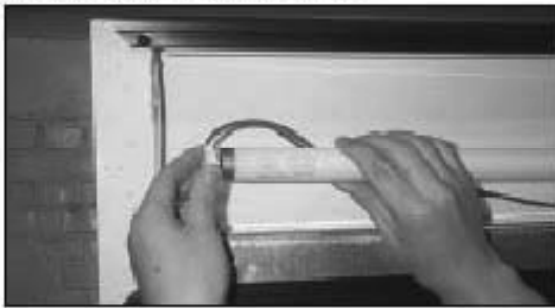

3. Separate the Lamp Socket.



4. Separate the Lamp out of the Lamp Holder and replace it.

(TGM-72RS, 50RS)



1. Unscrew the left sign frame.



2. Unscrew the right sign frame.



3. Pull the sign panel carefully.



4. Separate the lamp socket
Separate the lamp out of the lamp holder and
replace it.

REPLACEMENT OF MAIN COMPONENTS

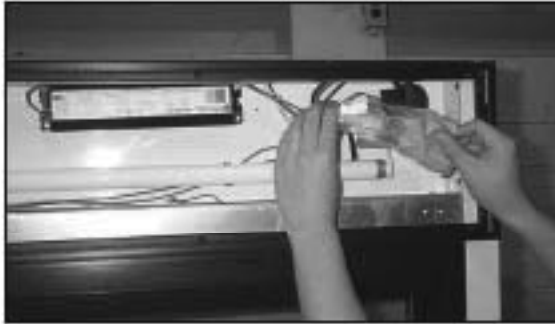

5. Take out the Clamp securing wires.



6. Separate the Ballast Connectors.



7. Unscrew two screws securing the Ballast and replace it.

REPLACEMENT OF MAIN COMPONENTS

1-2). LAMP FOR CABINET LINER(TGM-69R,72ES, 48R, 50RS, 35R)



1. Take out the Doors and separate the Lamp from the Lamp Holder.

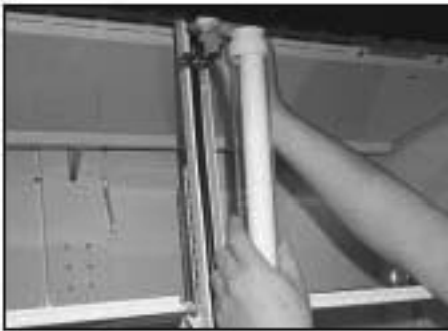

2. Separate the Lamp Socket.

REPLACEMENT OF MAIN COMPONENTS



3. Separate the Lamp Shield End Cap.



4. Replace the Lamp.

REPLACEMENT OF MAIN COMPONENTS

1-3). LAMP(TGM-22R, 14R)



1. Unscrew four screws securing the Sign Frame End and separate the Sign Frame End.



2. Separate the Sign Panel.



3. Separate the Lamp Sockets and replace the Lamp.

REPLACEMENT OF MAIN COMPONENTS



4. Separate connector of the ballast.



5. Unscrew two screws securing the Ballast.



6. Separate the Lamp Sockets to replace the Lamp for Cabinet Liner.



7. Separate the Lamp Shield End Cap and replace the Lamp.

REPLACEMENT OF MAIN COMPONENTS

1-4) . LAMP BASE ASSEMBLY FOR VERTICAL LAMP SERIES



TGM-11RV



TGM-14RV, TGM-22RV

1. UNSCREW THE SCREWS OF THE HOUSING COVER



TGM-11RV



TGM-14RV, TGM-22RV

2. PULL OUT THE HOUSING



3. UNSCREW THE SPECIAL BOLT THAT IS FIXING THE LAMP BASE ASSEMBLY (3POINTS)



4. PULL OUT THE LAMP BASE ASSEMBLY

REPLACEMENT OF MAIN COMPONENTS



5. SEPARATE THE FLUORESCENT LAMP FROM THE LAMP HOLDER



6. PULL OUT THE LAMP CAP FROM THE LAMP CASE



7. REPLACE THE FLUORESCENT LAMP AFTER PULL OUT THE FLUORESCENT LAMP FROM THE LAMP CASE.

REPLACEMENT OF MAIN COMPONENTS

1. LAMP (TGM-11R, 5R)



1. Unscrew two screws securing the Lamp Shield.



2. Disassemble the Lamp Shield.

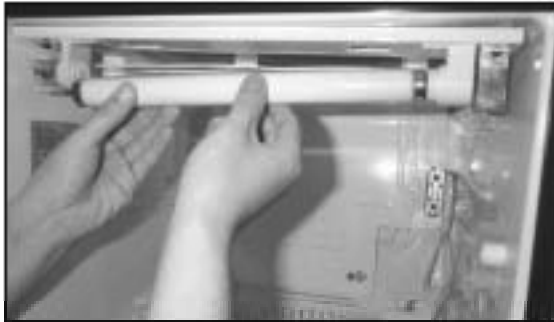

3. Separate the Lamp out of the Lamp Holder and replace it.

REPLACEMENT OF MAIN COMPONENTS

2-1). TEMPERATURE CONTROL AND LIGHT SWITCH(TGM-69R,72RS,48R,50RS,35R)



1. Unscrew four screws securing the Thermostat control plate.

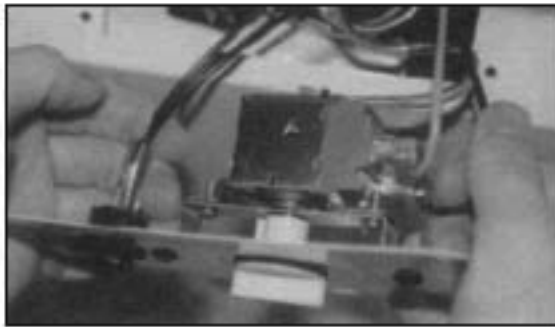

2. Pull out the Thermostat control plate.



3. Separate the Receptacles out of the Thermostat and Lamp Switch.



4. Separate the Tube of Thermostat from the Evaporator.

REPLACEMENT OF MAIN COMPONENTS



5. Separate the Thermostat Knob out of the Thermostat.



6. Unscrew two screws securing the Thermostat.



7. Separate the Thermostat out of the Thermostat plate.



8. Unscrew two screws securing the Thermostat out of the Thermostat Bracket.

REPLACEMENT OF MAIN COMPONENTS

2-2) THERMOSTAT CONTROL AND LIGHT SWITCH(TGM-14R, 14RV)



1. Unscrew two screws securing the Thermostat Plate.



2. Pull out the Thermostat Plate.



3. Separate the Receptacles out of the Thermostat and Light Switch.

REPLACEMENT OF MAIN COMPONENTS



4. Separate the Tube of Thermostat from the Evaporator.



5. Separate the Thermostat out of the Thermostat Plate.

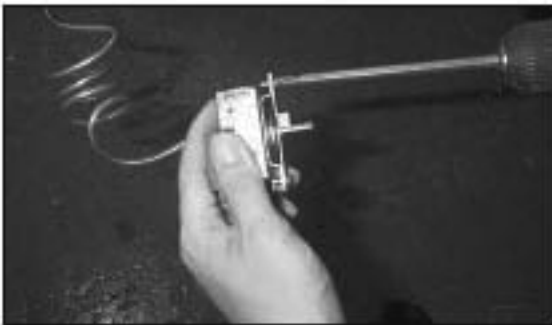

6. Unscrew two screws securing the Thermostat out of the Thermostat Bracket.

REPLACEMENT OF MAIN COMPONENTS

2-3) THERMOSTAT CONTROL AND LIGHT SWITCH(TGM-11R, 11RV)



1. Unscrew six screws securing the Duct.



2. Unscrew four screws securing the Thermostat Plate.



3. Separate the Receptacles out of the Thermostat and Lamp Switch.

REPLACEMENT OF MAIN COMPONENTS

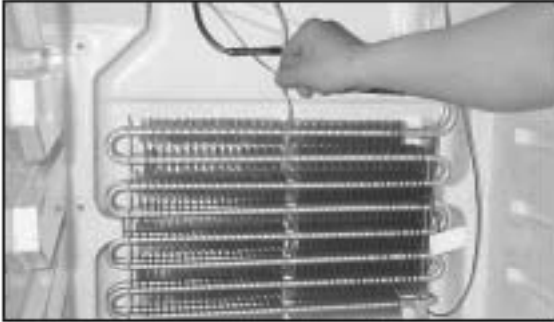

4. Separate the Tube of Thermostat from the Evaporator Coil.

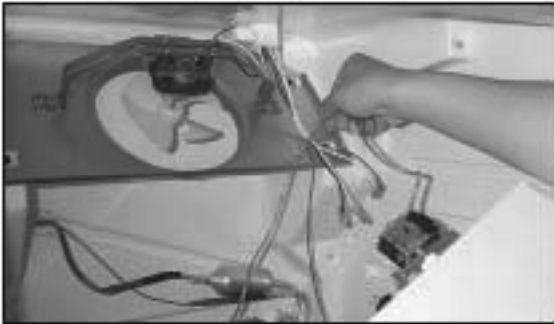

5. Pull out the Thermostat plate.



6. Separate the Thermostat out of the Thermostat plate.

REPLACEMENT OF MAIN COMPONENTS

2-4) THERMOSTAT CONTROL AND LIGHT SWITCH(TGM-5R)



1. Unscrew two screws securing the Control Box.



2. Separate the Connectors.



3. Unscrew two screws securing the Tube of Thermostat out of the Thermostat Fixture.

REPLACEMENT OF MAIN COMPONENTS

3-1) EVAPORATOR FAN MOTOR & BLADE(TGM-69R,72RS,48R,50RS,35R)



1. Unscrew four screws securing the Thermostat Plate.

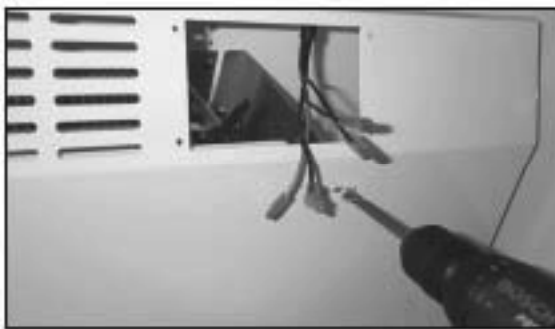

2. Unscrew eight screws securing the Duct.



3. Separate the Duct.



4. Unscrew four screws securing the Evaporator Drain Pan.

REPLACEMENT OF MAIN COMPONENTS



5. Separate the Evaporator Drain Pan.



6. Unscrew four screws securing the Evaporator Guide *L, *R and separate them.



7. Separate the Vinyl Cover securing the Evaporator Fan Motor.

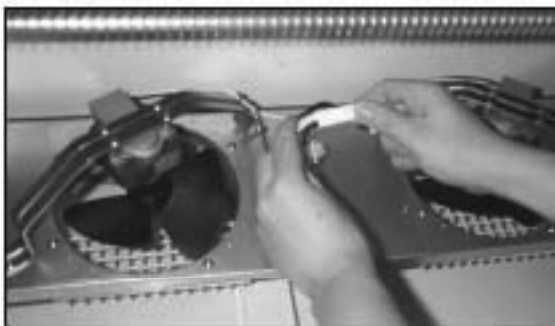

8. Separate the Connectors of Evaporator Fan Motor.

REPLACEMENT OF MAIN COMPONENTS



9. Pull out of the Evaporator Fan Motor Harness.

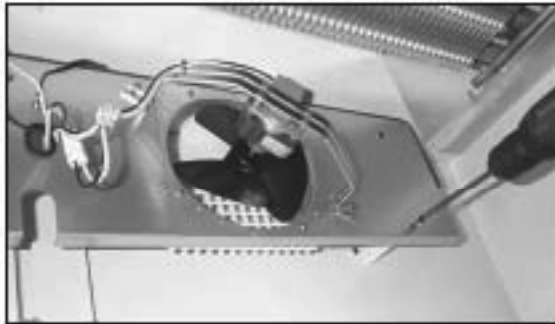

10. Unscrew two screws securing the Evaporator Fan Motor Bracket.



11. Separate the Evaporator Fan Motor Bracket.

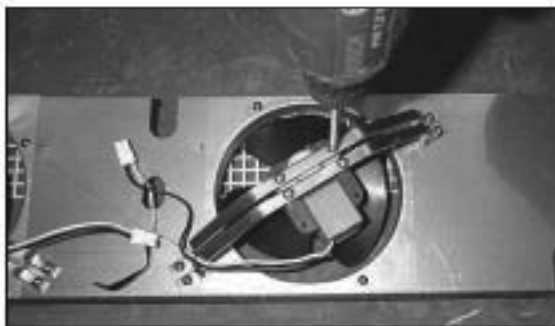

12. Unscrew four screws securing the Evaporator Fan Motor out of the Bracket.

REPLACEMENT OF MAIN COMPONENTS

3-2) EVAPORATOR FAN MOTOR & BLADE(TGM-22R, 22RV)



1. Unscrew the screw securing the Evaporator Fan Motor Guard.



2. Separate the Evaporator Fan Motor Cover.



3. Replace the Evaporator Fan Motor.

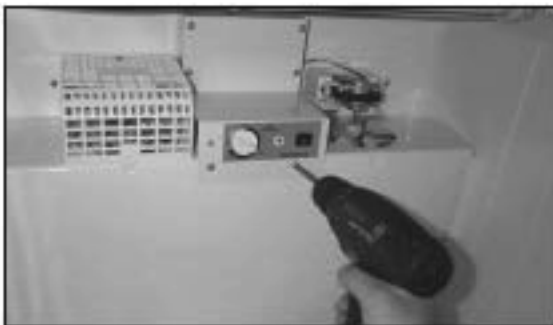

4. Unscrew four screws securing the Thermostat Plate.

REPLACEMENT OF MAIN COMPONENTS



5. Separate the Thermostat Plate.
Pull out the tube of Thermostat out of the Evaporator Coil.



6. Unscrew four screws securing the Duct.



7. Separate the Duct.

REPLACEMENT OF MAIN COMPONENTS

3-3) EVAPORATOR FAN MOTOR & BLADE(TGM-14R, 14RV)



1. Unscrew the screws securing the Thermostat Plate and two screws securing the Duct.



2. Separate the Duct.
(Caution: Pulling the Duct in to the front can cause the Fan Blade to be bent.)



3. Unscrew four securing the Evaporator Fan Motor Bracket.



4. Separate the Connectors of Fan Motor, the Nut and replace the Fan Blade.

REPLACEMENT OF MAIN COMPONENTS



5. Unscrew two screws securing the Evaporator in case of replacing it.

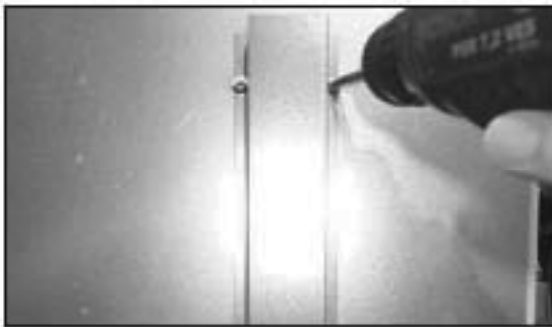

6. Separate Suction Pipe Cover on the Rear Cabinet.

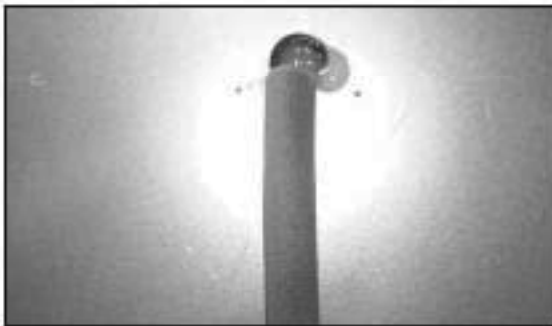

7. Separate the Sealing Tube.

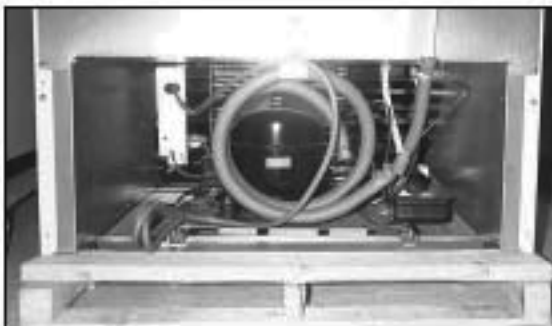

8. Replace the Suction Pipe with welding machine.

REPLACEMENT OF MAIN COMPONENTS



9. Pull out the Evaporator Coil.
(Caution: Pulling the Evaporator can cause the Cabinet Liner to be scratched.)



10. Separate the Evaporator Coil out of the Evaporator Drain Pan and repair the Evaporator Coil.

REPLACEMENT OF MAIN COMPONENTS

3-4) EVAPORATOR FAN MOTOR & BLADE(TGM-11R, 11RV)



1. Unscrew the screws securing the Duct.



2. Unscrew the screws securing the Thermostat Plate.



3. Separate the harness out of the Thermostat and Lamp Switch.



4. Separate the Evaporator Fan Motor Bracket.

REPLACEMENT OF MAIN COMPONENTS

4-1) CONDENSER FAN MOTOR & BLADE

(TGM-69R, 48R, 35R)



1. Unscrew four screws securing the Bottom Grill.



2. Separate the Compressor Harness out of the Switch Box.

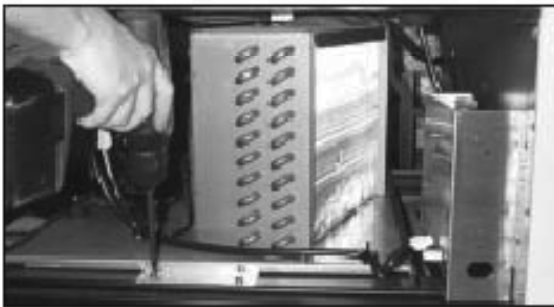

3. Unscrew four screws securing the Compressor Base.



4. Pull the Compressor Base and separate the Condenser Fan Motor.

(TGM-72RS, 50RS)



REPLACEMENT OF MAIN COMPONENTS

4-2) CONDENSER FAN MOTOR & BLADE (TGM-22R, 22RV)

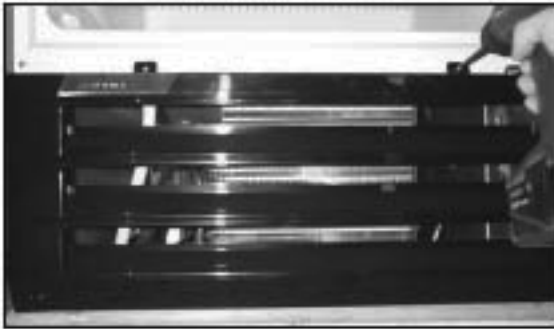

1. Unscrew four screws securing the Bottom Grill.

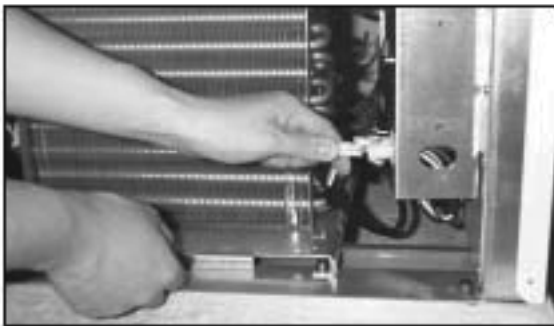

2. Separate the Connector out of the Switch Box.

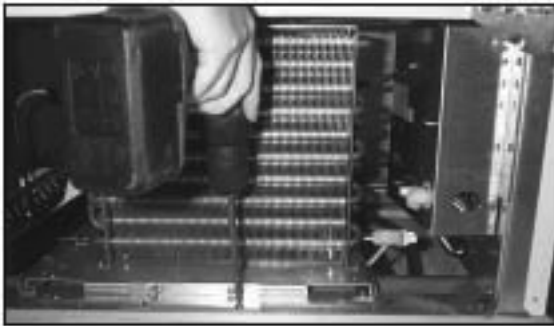

3. Unscrew four screws securing the Compressor Base.

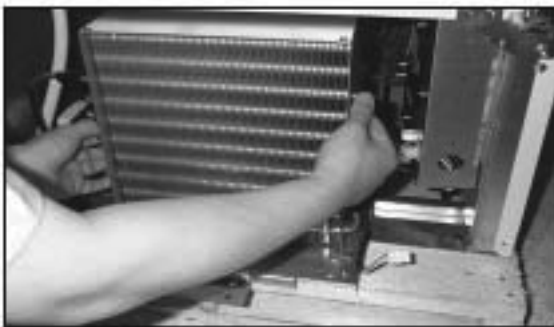

4. Pull the Compressor Base and separate the Condenser Fan Motor.

REPLACEMENT OF MAIN COMPONENTS

4-3) CONDENSER FAN MOTOR & BLADE (TGM-14R, 14RV, 11R, 11RV)



1. Unscrew four screws securing the Bottom Grill.



2. Separate the Connector out of the Switch Box.



3. Unscrew four screws securing the Condenser Fan Motor Bracket.



4. Pull the Condenser Fan Motor with care.

REPLACEMENT OF MAIN COMPONENTS



5. Separate the Fan Motor Bracket.

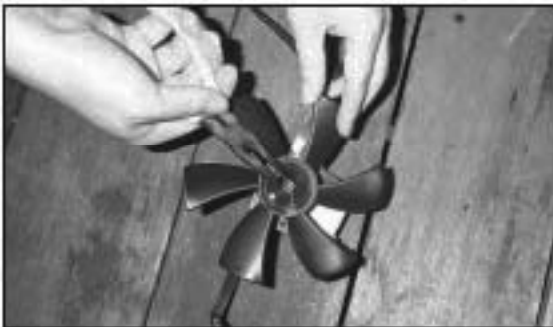

6. Separate the nut and replace the Fan Blade.

REPLACEMENT OF MAIN COMPONENTS

5) DOOR (TGM-22R, 22RV, 14R, 14CRV)



1. Separate the Sign Frame End and Sign Panel.



2. Separate the Door Hinge Top and Door.