

Persons under age 18 are not permitted to operate or  
have accessibility to operate this equipment per  
U.S. Dept. of Labor Employment Standards  
Administration Fact Sheet No. ESA91-3.

**univex**

**TO INSURE BOTH SAFE AND  
TROUBLE-FREE PERFORMANCE WE STRESS  
THAT ALL PERSONNEL THAT WILL BE  
INVOLVED WITH YOUR NEW UNIVEX G PEELER  
MUST READ AND UNDERSTAND THESE  
INSTRUCTIONS BEFORE ATTEMPTING TO  
OPERATE THIS UNIT.**

.....

**WE APPRECIATE YOUR COOPERATION AND  
YOUR BUSINESS. SHOULD THERE BE A  
QUESTION OR IF WE CAN BE OF FURTHER  
ASSISTANCE, PLEASE CALL US,  
1-603-893-6191.**

TABLE OF CONTENTS

<u>DESCRIPTION</u>	<u>PAGE</u>
Table of Contents .....	1
Overall View of Peeler .....	2
Installation .....	3
Operating Instructions .....	3
Cleaning .....	3
Maintenance .....	4
Housing Assembly .....	5 - 7
Disk Drive Assembly .....	8
Motor Drive Assembly .....	9
Wiring Diagram 115V, 60HZ, 1PH .....	10
Wiring Diagram 220-230V, 50/60HZ, 1PH .....	11
Wiring Diagram 115V, 60HZ, 1PH Canadian Specification Only .....	12
Wiring Diagram 220-240V, 50HZ, 1PH British Specification Only .....	13
Warranty .....	Back Cover

**OPERATOR SAFETY**

**IT IS A VIOLATION OF UNITED STATES DEPARTMENT OF LABOR REGULATIONS TO PERMIT OPERATION OF THE G-PEELER BY ANY PERSON UNDER THE AGE OF 18 YEARS.**

**READ AND MAKE SURE THAT YOU UNDERSTAND INSTRUCTIONS AND SAFETY WARNINGS BEFORE ATTEMPTING TO OPERATE THE PEELER.**

**NEVER PUT FINGERS OR HANDS IN PEELER WHILE THE PEELER IS OPERATING OR SERIOUS INJURY COULD RESULT.**

**G PEELER**  
**OVERALL VIEW OF PEELER**  
**FIGURE 1**

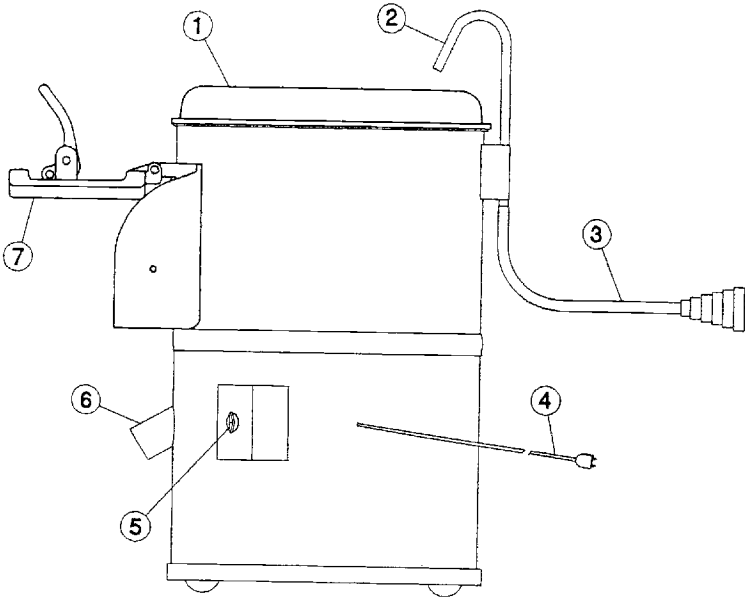

1 - COVER

2 - WATER INLET TUBE

3 - FLEXIBLE HOSE

4 - ELECTRICAL CORD

5 - TIMER KNOB

6 - DRAIN OUTLET

7 - DISCHARGE DOOR

## INSTALLATION

After peeler has been removed from carton, remove cover, shipping spacer, water inlet hose and any literature packed in the peeler. Place peeler on sink drain board or any suitable location. Be sure that drain outlet [Fig. 1 (6)] is located so that water and peelings will discharge into sink.

Pull up into position water inlet tube (Fig. 1 [2]). Turn tube in holder positioning it towards the center of the peeler.

Install cover. Slip small end of flexible hose (Fig 1 [3]) over water inlet tube. Attach large end into cold water faucet; close and latch discharge door [Fig. 1 [7]]

**CAUTION:** Before making electrical connections, check the specifications on the nameplate to make sure that they agree with those on your electric service. Plug electric cord (Fig. 1 [4]) into AC outlet.

## OPERATING INSTRUCTIONS

After machine has been properly installed, adjust cold water faucet for a small flow of water to flush away peelings.

To start peeler: Turn timer knob (Fig. 1 [5]) beyond desired time, then turn back to three minute mark. This is the average time required to peel a 20 lb. load.

Insert potatoes or other vegetables through opening in cover (Fig. 1 [1]).

Timer (fig 1 [5]) will automatically stop unit. Inspect vegetables. If you are satisfied with peeling, unlatch discharge door. Have receptacle ready to receive vegetables - or discharge directly into sink. To eject the vegetables, start machine (by turning timer), hold door partly open. Rotation of peeling disc will eject load. Timer may be turned off and on without damage.

Peeling time will vary with the size, shape and condition of potatoes or vegetables. The three minute average peeling time may have to be increased or decreased accordingly. The estimated capacity of 20 lbs. is based on US Grade 1 potatoes. Unusually large or long potatoes may require a slight reduction in load to obtain satisfactory results.

**CAUTION: DO NOT OVERLOAD. THERE SHOULD BE AT ALL TIMES ROOM IN THE PEELER FOR COMPLETE TUMBLING OF VEGETABLES FOR PROPER PEELING.**

Noise emissions below 70 db(A).

## CLEANING

**WARNING: DISCONNECT ELECTRIC POWER BEFORE CLEANING.**  
Proper cleaning is essential for insuring the long life of your UNIVEX peeler.

As soon as peeling is complete and before peeled particles dry and stick, remove cover (Fig. 2 [2]) and peeling disc (Fig. 3 [3]), wash thoroughly with cold water only.

Wash inside of peeler and flush out thoroughly with flexible hose. Allow discharge door to remain unlatched, thus prolonging the life of the door seal.

## MAINTENANCE

**WARNING: DISCONNECT THE ELECTRICAL POWER PRIOR TO PERFORMING ANY MAINTENANCE**

Maintenance is simple and has been kept to a minimum through modern engineering design.

To expose driving mechanism for service, lay unit on side and remove bottom cover (Fig. 2 [11]).

To replace belt, (Fig. 4 [3]) release tension spring (Fig. 4 [8]) to loosen belt. Hold motor in slack position and roll belt off the large pulley. (Fig. 4 [5]) Reverse procedure to install new belt. Do not use any metallic tools to force belt over pulleys. To do so will greatly shorten belt life.

**HOUSING ASSEMBLY  
FIGURE 2**

ILLUS. NO.	PART NO.	DESCRIPTION	QTY.
1	1120304	HOUSING	1
2	1120029	COVER	1
3	1120038	TUBE, WATER INLET	1
4	1200008	SCREW, PPHD 8-32 X 3/8	11
5	1120019	HOSE, WATER INLET	1
6	1120060	CORD, ELECTRICAL, 115V, With Plug	1
	1120060-1	CORD, ELECTRICAL, 220/230V, Without Plug	1
7	1120048	STRAIN RELIEF, CORD	1
8	1120064	LABEL, TIMER	1
9	1120062	TIMER, 5 MIN., 1 POL, 115V	1
	1120063	TIMER, 5 MIN., 2 POL, 220/230V	1
10	7100028	KNOB, TIMER	1
11	1120061	COVER, BOTTOM	1
12	2300125	FEET, RUBBER	3
13	1120036	HOSE, DRAIN	1
14	4400155	SCREW, HEX HD 1/4-20 X 1/2	2
15	1120040	PIN, DISCHARGE DOOR	1
16	1120028	HANDLE, DISCHARGE DOOR	1
17	4400154	SET SCREW, HEX 10-32 X 1/4	1
18	1120039	BAR, LATCH	1
19	1120041	STOP, DOOR	2
20	1120042	PIN, HINGE	1
21	1120027	DOOR, DISCHARGE	1
22	1120022	SEAL, DISCHARGE DOOR	2FT
23	1120026	HOUSING, DISCHARGE	1
24	1120023	GASKET, HOUSING CHUTE	1

**HOUSING ASSEMBLY**  
**FIGURE 2 (cont)**

ILLUS. NO.	PART NO.	DESCRIPTION	QTY
25		RESERVED	
26		RESERVED	
27	4400270	LABEL, WARNING (Not Shown)	1
28		RESERVED	
29	4400079	SCREW M4-0.7 X 6MM LG (Not Shown)	2
34	1200465	SCREW, SS RD HD SLOTTED 1/4-20 X 5/8	3
<b><u>FOR CANADIAN SPECIFICATIONS ONLY</u></b>			
6	1120060-2	CORD 115V, CSA ONLY	1
30	4400238	CIRCUIT BREAKER	1
31	4400227	LABEL, RESET	1
32	4400226	LABEL, CSA (not shown)	1
<b><u>FOR BRITISH SPECIFICATIONS ONLY</u></b>			
6	8800209	CORD 220-230, BRITISH ONLY	1
7	7100107	STRAIN RELIEF, CORD	1
30	7100097	CIRCUIT BREAKER	1
31	4400227	LABEL, RESET	1
32	4400423	LABEL, CE (NOT SHOWN)	1
33	4400335	LABEL, GROUND (NOT SHOWN)	1



**HOUSING ASSEMBLY**  
**FIGURE 2**

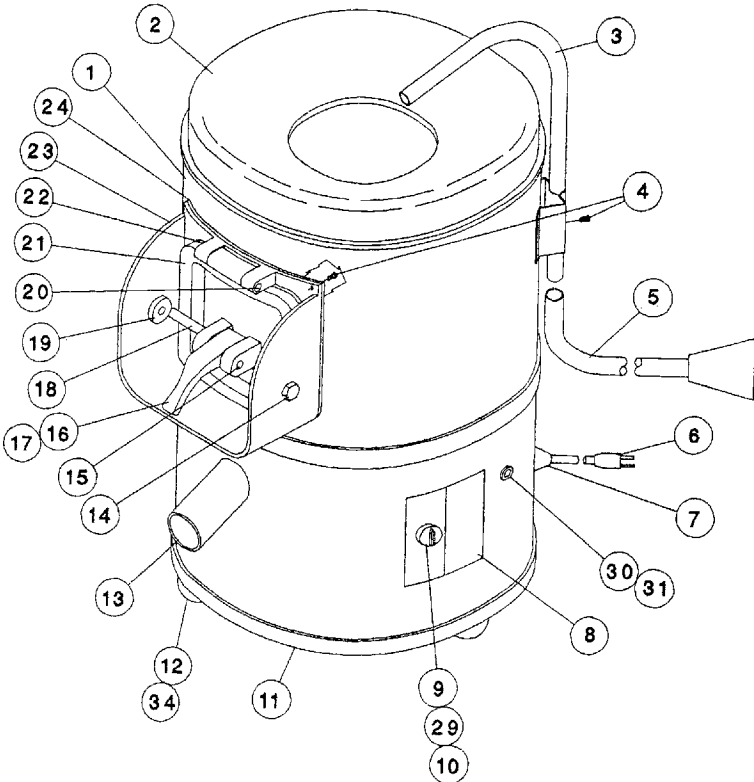

**DISK DRIVE ASSEMBLY**  
**FIGURE 3**

ILLUS. NO.	PART NO.	DESCRIPTION	QTY.
1	1120310	HOUSING, BEARING	1
2	1120307	DISC, DRIVE PEELING ASSY	1
3	1120002	DISC, DRIVE PEELING	1
4	4400230	KEY SQ. 3/16 X 1 1/2	1
5	6509012	SEAL, OIL	1
6	1030035	BEARING, BALL 5204ZZ	1
7	1200117	RETAINING RING, INT.	3
8	1030019	BEARING, BALL 6204LL	1
9	1120311	GASKET, BEARING HOUSING	1
10	1120318	RING, REINFORCEMENT	1
11	1200077	LOCKWASHER 5/16	4
12	1200206	SCREW, HEX HD SS 5/16-18 X 5/8	4
13	1120305	HOUSING, DIVIDER (PART OF ITEM 1 OF FIG. 2)	2

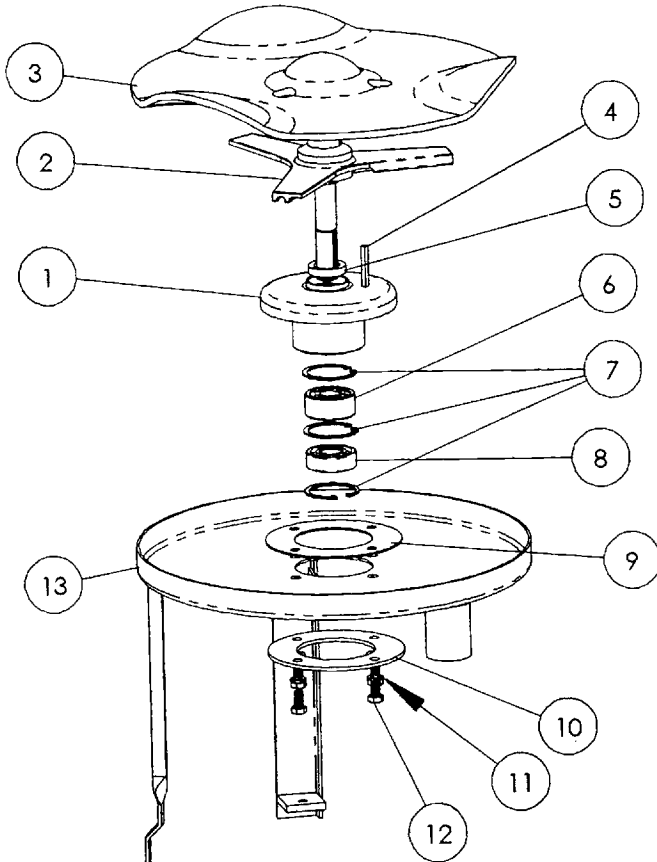

**MOTOR DRIVE ASSEMBLY**  
**FIGURE 4**

1	1200412	SET SCREW 1/4-20 X 1/4	2
2	1120302	PULLEY, DRIVE	1
3	1120303	BELT, POLY-V	1
4	1200119	RETAINING RING, EXT.	2
5	1120302	PULLEY, DRIVEN	1
6	1200036	SET SCREW 5/16-24 X 3/8	2
7	1120047	TAB. BELT TENSION	1
8	1120017	SPRING, BELT TENSION	1
9	2200021	TAB, TENSION SPRING, 115V	1
10	1120316	BOLT, MPTOR MOUNT	1
11	4400083	NUT, JAM 3/8-24	1
12	6090012	MOTOR 1/3HP, 100-120V/200-240V, 50/60HZ, 1PH	1
13	1120225	ROD, MOTOR PIVOT	1
14	1200060	NUT, HEX HD 10-32	2

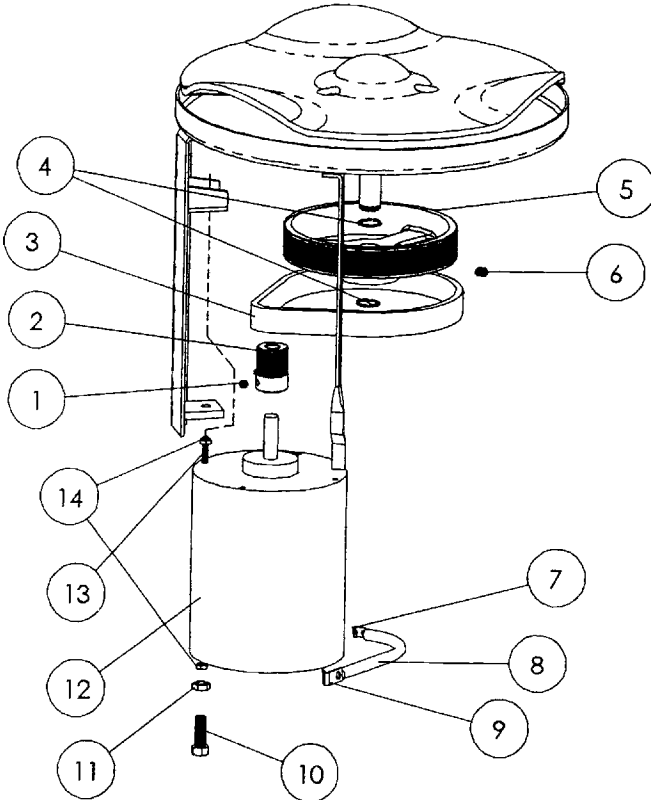

**WIRING DIAGRAM G-PEELER**  
115V, 60HZ, 1PH  
FIGURE 5

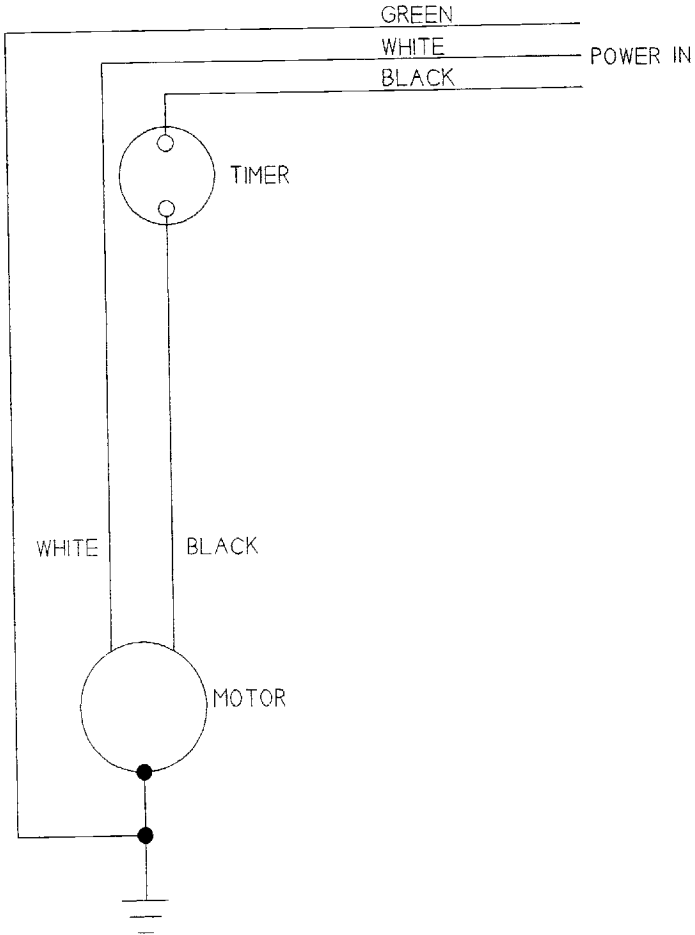

**WIRING DIAGRAM G-PEELER**  
**220-230V, 50/60HZ, 1PH**  
**FIGURE 6**

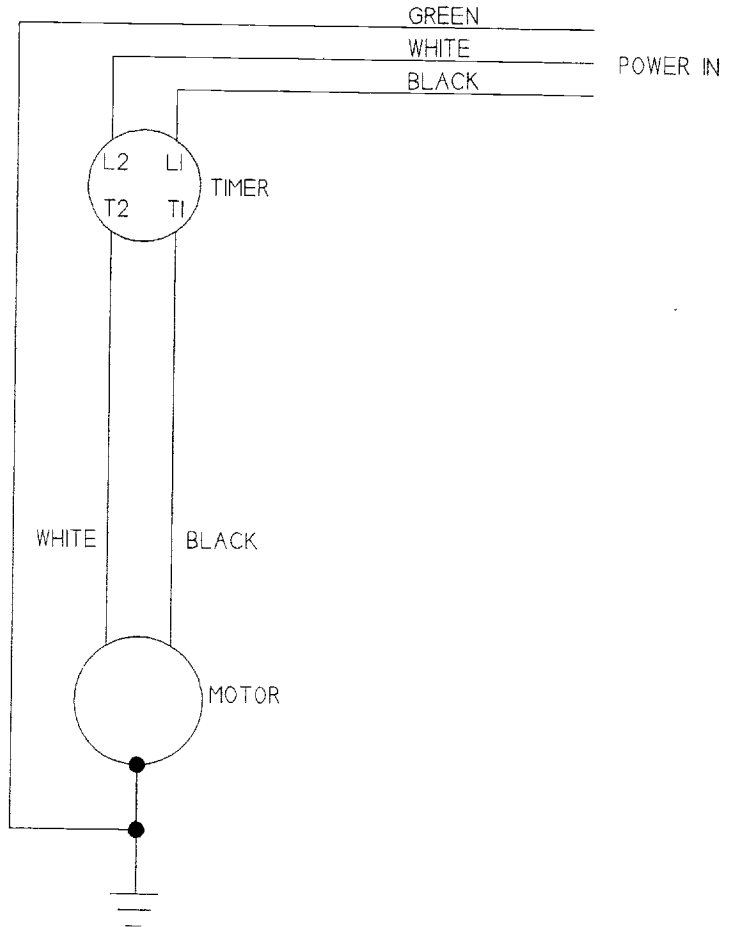

**WIRING DIAGRAM G-PEELER**  
**115V, 60HZ, 1PH**  
**FOR CANADIAN SPECIFICATIONS ONLY**  
**FIGURE 7**

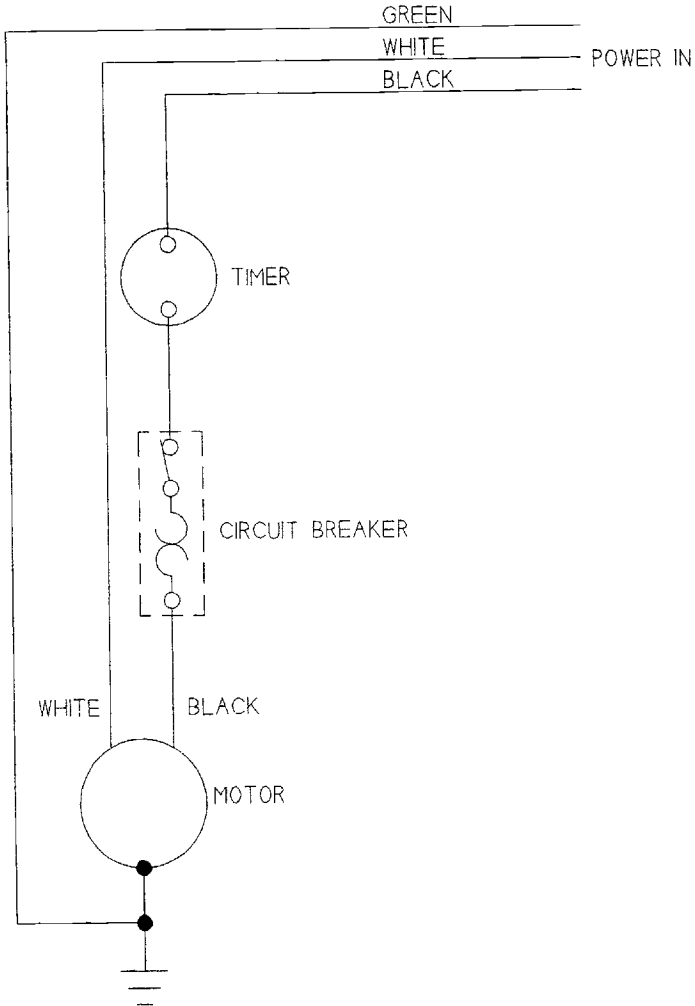

**WIRING DIAGRAM G-PEELER**  
**230V, 50HZ, 1PH**  
**FOR BRITISH SPECIFICATIONS ONLY**  
**FIGURE 8**

