



Pizza Tables, Big Top Salad/Sandwich Refrigerators & Compact Undercounters

(For “Quick Navigation”, Click On Topics or Sections Highlighted In Blue)



- ★ DESCRIPTION
- ★ INSTALLATION
- ★ OPERATION
- ★ MAINTENANCE
- ★ TROUBLESHOOTING
- ★ PARTS LISTS
- ★ WIRING DIAGRAMS

Warranty

(Continental USA Only)

The Seller warrants to the original purchaser, equipment manufactured by Seller to be free from defects in material and workmanship for which it is responsible. The Seller's obligation under this warranty shall be limited to replacing or repairing at Seller's option, without charge, F.O.B. Seller's factory, any part found to be defective and any labor and material expense incurred by Seller in repairing or replacing such part, such warranty to be limited to a period of one year from date of purchase or thirteen months from date of shipment from Seller's factory, whichever is earlier, provided terms of payment have been fully met. All labor shall be performed during regular working hours. Overtime premium charges will be at Buyer's expense.

Proof of purchase must be supplied to Seller to validate warranty. This warranty is valid only if equipment is properly installed, started-up and inspected by the dealer or authorized Victory Service agent.

Removal or alteration of the serial/data plate from any equipment shall be deemed to release Seller from all warranty obligations or any other obligations, expressed or implied.

This warranty does not cover Thermostat or Defrost Timer calibration and/or adjustment, freight damage, normal maintenance items outlined in Owner's Manual, adjustment of door mechanisms or replacement of light bulbs, fuses or batteries.

Any repairs or replacement of defective parts shall be performed by Seller's authorized service personnel. Seller shall not be responsible for any costs incurred if the work is performed by other than Seller's authorized service personnel. Reimbursement claims for part(s) or labor service costs must be made in writing. Model, cabinet serial numbers and installation location must be shown on the claim. A receipted bill from the servicing agency must accompany the claim, together with full details of the service problems, diagnosis and work performed. Victory reserves sole discretion whether further documentation on a claim is to be submitted.

Seller shall not be liable for consequential damages of any kind which occur during the course of installation of equipment, or which result from the use or misuse by Buyer, its employees or others of the equipment supplied hereunder, and Buyer's sole and exclusive remedy against Seller for any breach of the foregoing warranty or otherwise shall be for the repair or replacement of the equipment or parts thereof affected by such breach.

The foregoing warranty shall be valid and binding upon Seller if and only if Buyer loads, operates and maintains the equipment supplied hereunder in accordance with the instruction manual provided to Buyer. Seller does not guarantee the process of manufacture by Buyer or the quality of product to be produced by the equipment supplied hereunder and Seller shall not be liable for any prospective or lost product or profits of Buyer.

THE FOREGOING WARRANTY IS EXCLUSIVE AND IN LIEU OF ALL OTHER EXPRESS AND IMPLIED WARRANTIES WHATSOEVER. SPECIFICALLY THERE ARE NO IMPLIED WARRANTIES OF MERCHANTABILITY OR OF FITNESS FOR A PARTICULAR PURPOSE.

The foregoing shall be Seller's sole and exclusive obligation and Buyer's sole and exclusive remedy for any action, whether in breach of contract or negligence. In no event shall Seller be liable for a sum in excess of the purchase price of the item.

You may register online at www.victory-refrig.com, fax this completed page to (856) 428-7299, or copy and mail form below to Victory.

***NOTE:** The following mail-in form or online registration must be filled out and forwarded to Victory by the installer or customer within 10 days after start-up. Failure to do this will invalidate the warranties. Retain this information for your records.



110 WOODCREST ROAD
CHERRY HILL, NJ 08003-3648
TEL: (856) 428-4200 • FAX: (856) 428-7299

Cabinet Model No. _____

Cabinet Serial No. _____

(Data plate information located inside cooler on the upper left wall)

WARRANTIES NOT VALID UNLESS REGISTERED AT FACTORY WITHIN 10 DAYS AFTER START-UP DATE.

ORIGINAL DATE OF INSTALLATION _____

INSTALLATION COMPANY NAME _____

STREET _____ CITY _____ STATE _____ ZIP CODE _____

DISTRIBUTOR'S NAME _____

STREET _____ CITY _____ STATE _____ ZIP CODE _____

TABLE OF CONTENTS

	Page
SECTION 1 - DESCRIPTION.....	1
A. Specifications & Dimension.....	2
SECTION 2 - INSTALLATION.....	3
A. Receiving shipment.....	3
B. Removing plastic cover.....	3
C. Locating your new storage refrigerator/freezer.....	3-4
D. Installing legs.....	4
E. Removal of drawer assembly.....	4
F. Electric supply.....	5
G. Installation check list.....	5
H. Location of serial number/data plate.....	6
I. Warranty cards.....	6
SECTION 3 - OPERATION.....	7
A. Temperature control.....	7
B. Thermometer operation.....	8
C. Important operating facts.....	8
D. Food Pan Area.....	8
SECTION 4 - MAINTENANCE.....	9
A. Cleaning - Proper detergent use.....	9
B. Initial cleaning of cabinet.....	9
C. Periodic cleaning.....	10-11
D. Lubrication.....	11
SECTION 5 - TROUBLESHOOTING.....	13-15
SECTION 6 - PARTS LIST.....	17
A. Compact Undercounter Refrigerator & Freezer.....	18-21
B. Compact Undercounter Refrigerator Salad/Sandwich Unit.....	22-24
C. Big Top Salad/Sandwich Refrigerator.....	25-26
D. Pizza Prep Tables.....	27-28
SECTION 7 - ELECTRIC SCHEMATIC	29
A. Compact Undercounter Refrigerator	30
B. Compact Undercounter Freezer.....	31
C. Big Top Salad/Sandwich Refrigerator	32
D. Pizza Prep Table	33

SECTION 1

DESCRIPTION

Compact Undercounter Refrigerators, Freezers, Salad/Sandwich Refrigerators and Pizza Tables.

- **Compact Undercounters** - Available in 27” and 48” widths. The stainless steel top can be flat or with a backsplash. Drawer models (27” units only) have two stainless steel drawer fronts with heavy duty stainless steel slides and ball bearings.
- **Compact Salad/Sandwich Refrigerators** - Available in 27” and 48” widths with stainless steel telescoping lid and utility shelf. The 27” unit has openings in the top for eight (8) pans. The 48” units have openings in the top for eight (8), ten (10), or twelve (12) pans.
*Note: These units do not consist of a backsplash
- **V-Line Big Top Salad/Sandwich Refrigerators** - Available in 30-3/4”, 46-3/4” or 61-1/4” widths with stainless steel telescoping lids and utility shelf. The 30-3/4” units have openings in the top for twelve (12) pans. The 46-3/4” units have openings in the top for twelve (12) or eighteen (18) pans. The 61-1/4” units have openings in the top for twelve (12), sixteen (16), eighteen (18), or twenty-four (24) pans.
- **V-Line Pizza Tables** - Available in 40-1/4”, 64-1/4” and 88-1/4” widths. Pizza tables are designed with a cold wall pan rail system and forced air cabinet storage. Each cold wall rail accommodates standard serving pans.

SPECIFICATIONS AND DIMENSIONS

MODEL	DIMENSIONS W X D X H (in)	CAPACITY (Cu Ft)	TOTAL AMPS	VOLTS	H.P.	NO. OF SHELVES	NO.OF 1/6 SIZE PANS	CRATED WEIGHT
COMPACT UNDERCOUNTER REFRIGERATORS & FREEZERS								
UR-27-SALA	27 X 30 1/2 X 42	6.5	5.6	115-60-1	1/5	2	(6) 1/6 PANS & (2) 1/9 PANS	175 LBS
UR-48-8A	48 X 30 1/2 X 42	11.5	6.5	115-60-1	1/5	4	8	250 LBS
UR-48-10A	48 X 30 1/2 X 42	11.5	6.5	115-60-1	1/5	4	10	250 LBS
UR-48-12A	48 X 30 1/2 X 42	11.5	6.5	115-60-1	1/5	4	12	250 LBS
UR-27-SST	27 X 30 1/2 X 36	7.0	5.6	115-60-1	1/5	2	-	155 LBS
URD-27-SST	27 X 30 1/2 X 36	7.0	6.0	115-60-1	1/5	-	-	195 LBS
UF-27-SST	27 X 30 1/2 X 36	7.0	6.7	115-60-1	1/3	2	-	160 LBS
UFD-27-SST	27 X 30 1/2 X 36	7.0	7.1	115-60-1	1/3	-	-	200 LBS
UR-27-SBS	27 X 30 1/2 X 40 1/2	7.0	5.6	115-60-1	1/5	2	-	157 LBS
URD-27-SBS	27 X 30 1/2 X 40 1/2	7.0	6.0	115-60-1	1/5	-	-	197 LBS
UF-27-SBS	27 X 30 1/2 X 40 1/2	7.0	6.7	115-60-1	1/3	2	-	165 LBS
UFD-27-SBS	27 X 30 1/2 X 40 1/2	7.0	7.1	115-60-1	1/3	-	-	205 LBS
UR-48-SST	48 X 30 1/2 X 36	12.5	6.0	115-60-1	1/5	4	-	218 LBS
UF-48-SST	48 X 30 1/2 X 36	12.5	7.1	115-60-1	1/3	4	-	225 LBS
UR-48-SBS	48 X 30 1/2 X 40 1/2	12.5	6.0	115-60-1	1/5	4	-	220 LBS
UF-48-SBS	48 X 30 1/2 X 40 1/2	12.5	7.1	115-60-1	1/3	4	-	227 LBS
V-LINE BIG TOP SALAD / SANDWICH REFRIGERATORS								
UR-3-BT	30 3/4 X 34 X 45 3/4	8.0	4.9	115-60-1	1/5	2	12	225 LBS
UR-4-12-BT	46 3/4 X 34 X 45 3/4	10.0	7.0	115-60-1	1/4	4	12	240 LBS
UR-4-18-BT	46 3/4 X 34 X 45 3/4	10.0	7.0	115-60-1	1/4	4	18	250 LBS
UR-5-12	61 1/4 X 28 1/2 X 42 7/8	15.0	7.0	115-60-1	1/4	4	12	300 LBS
UR-5-16	61 1/4 X 28 1/2 X 42 7/8	15.0	7.0	115-60-1	1/4	4	16	305 LBS
UR-5-18-BT	61 1/4 X 34 X 45 3/4	15.0	7.0	115-60-1	1/4	4	18	350 LBS
UR-5-24-BT	61 1/4 X 34 X 45 3/4	15.0	7.0	115-60-1	1/4	4	24	355 LBS
V-LINE PIZZA TABLES								
PT-40-S	40 1/4 X 34 X 45	7.7	6.8	115-60-1	1/4	2	(1) 12 X 35	400 LBS
PT-64-S	64 1/4 X 34 X 45	16.9	7.5	115-60-1	1/3	4	(2) 12 X 27	490 LBS
PT-88-S 88	88 1/4 X 34 X 45	26.2	10.0	115-60-1	1/2	6	(2) 12 X 27 & (1) 12 X 20	525 LBS

50 CYCLE UNITS AVAILABLE - CONTACT FACTORY

“End Of Section, Click Here For Table Of Contents”

SECTION 2

INSTALLATION

A. Receiving Shipment

Upon arrival, examine the exterior of the carton for any signs of rough handling. It is advisable that the shipping carton be partially removed in order to examine the cabinet for any possible concealed damages which might have occurred during shipment.

If no damages are evident, replace the shipping carton to protect the cabinet during local delivery. If the cabinet is damaged, it should be noted on the delivery slip or Bill of Lading and signed to that effect. A claim must be filed immediately against the carrier indicating extent and estimated cost of damage incurred.

B. Removing Protective Plastic Covering

WARNING

***DO NOT, Under Any Circumstances
Lay Your New Equipment Down on Either
The Back, Front or Sides.***

Remove the plastic covering by starting from one edge or corner carefully peeling the plastic from the metal surfaces.

CAUTION:

***Do not use scrapers or putty knives
to remove plastic covering.***

C. Locating your New Storage Freezer, Refrigerator

The following conditions should be considered when selecting a location for your refrigerator or freezer!!!!

1. Floor Load - The floor on which the refrigerator will rest must be free of vibration and suitably strong enough to support the combined weights of the refrigerator plus the maximum product load weight, it is generally conceded that a safe figure is 35 pounds for each net cubic foot of storage space. For example, a 10 cubic foot refrigerator could possibly hold approximately 350 pounds of products. (10 x 35 = 350)

2. Clearance - Do not remove the spacer from the rear of the compact undercounter. This guarantees sufficient air circulation to the condensing unit. Pizza tables and Big Top refrigerators require a minimum clearance of 3" between the back of the cabinet and the wall.

C. Locating your New Storage Freezer, Refrigerator (continued)

- 3. Ventilation** - The air cooled, self-contained refrigerator or freezer demands a sufficient amount of cool clean air. Avoid placing the refrigerator or freezer near heat generating equipment, such as ovens, ranges, heaters, fryers, steam kettles, etc., and out of direct sunlight. Avoid locating the self-contained refrigerator or freezer in an unheated room or where the room temperature drops below 55°F.
- 4. Ambient Temperature** - Salad/Sandwich refrigerator and pizza tables are approved for operation under NSF-7 (+41°F) in a maximum ambient of +86°F.

D. Installing Legs or Casters

Correct installation is very important to proper operation. This model must be - *level when it is installed*. If cabinet is not level...

1. Doors may not seal properly.
2. Defrost water may overflow coil drain pan.
3. An excessive amount of ice may accumulate in coil drain pan of freezer models.

This model is supplied with adjustable type legs for leveling purposes. Legs are packaged and taped with the cabinet for shipment. The legs must be secured to the leg braces on the underside of the cabinet. The legs should be installed immediately after shipping skid has been removed.

Tip the model in one direction, block it from falling by using several pieces of 2 x 4 lumber or other suitable material. Install legs securely while the model is in that position. Repeat this procedure to install the remaining two legs.

Note: The above information pertains to “Casters” also.

E. Removal of Drawer Assembly

1. Remove drawers from cabinet by pulling the drawer forward and lifting rollers out of notched front end of slide.
2. Push slide back so that slide support rollers clear retaining strap. Lift out left hand and right hand slides.
3. Lift front end of slide support channels to disengage rivets from keyhole slots in front of mounting bracket. Pull forward slightly to disengage rear rivets from keyholes in rear bracket. Lift out side support channel.
4. Remove screws holding front brackets on both sides of tank.
5. Rear brackets may be taken out if necessary by removing thumb screws holding them to the sides of the tank.

F. Electric Supply

The wiring must be done by a qualified electrician in accordance with local electrical codes. A separate ground wire must be supplied for all installations.

A properly wired refrigerator or freezer will assure proper operation. Please consult the “Data” plate attached to the compressor for the correct electrical requirements. Supply voltage requirements are on the cabinet serial plate.

It is recommended that a direct, properly fused line of the proper size wire be installed from the main supply to your refrigerator or freezer. It is most important that a voltage reading be made at the compressor motor electrical connections, or as close to the compressor motor as possible at start-up and while the refrigerator or freezer is in operation, to insure that the correct voltage required by the compressor is being supplied.

Low or high voltage can detrimentally affect the refrigeration unit and thereby void its warranty.

G. Installation Check List

After the cabinet has been installed, leveled and cleaned as described in the preceding paragraphs, refer to the following check list prior to start-up.

- Full voltage of the correct type, on a line not affected by the operation of other electrical appliances, must be available at the condensing unit junction box during operation. Condensing units are designed to operate with a voltage fluctuation of plus or minus 10% of the voltage indicated on the cabinet electrical data plate. Burnout of a condensing unit due to exceeding the high or low voltage limits will void the factory warranty.
- Check all refrigeration lines to make sure they are not severely dented, kinked or rubbing.
- Check condenser fan for freedom to rotate without striking any stationary members.
- Cabinet must be properly leveled.

H. Location of Serial Number/Data Plate

The serial data plate is mounted on the upper left interior tank wall inside the cabinet.

Note: When ordering replacement parts, you must include the complete cabinet model and serial numbers!

I. Warranty Cards

Locate the warranty cards at the rear of this manual. Fill out all three cards (“Factory Record Card”, “Distributor’s Record Card” and “Customer’s Record Card”) and mail the Factory and Distributor’s cards as directed. The customer’s card must be retained by the customer.

SECTION 3 OPERATION

A. Temperature Control

Temperature controls are factory set to maintain a food temperature of 38°F (3.3°C) to 40°F (4.4°C) for refrigerators and 0°F (-17°C) to -5°F (-20.5°C) for freezers.

Temperature Control for Salad/Sandwich Units (UR-27-SALA; UR-48-8A, 10A & 12A)

The temperature control has two adjustments:

- The “Cut in” temperature
- The differential between “Cut in” and “Cut out” temperatures

The salad units have been adjusted to provide a “Cut in” temperature of 39° F and a “Cut out” temperature of 32° F for the INLET AIR TO THE EVAPORATOR.

Fixed Timer to Guard Against “Freeze Ups”

The salad units use a fixed defrost timer to guard against “Freeze Ups”. Also the timer has a six (6) hour cycle which includes twenty (20) minutes of “OFF” time. Observe the diagram and information below for further assistance.

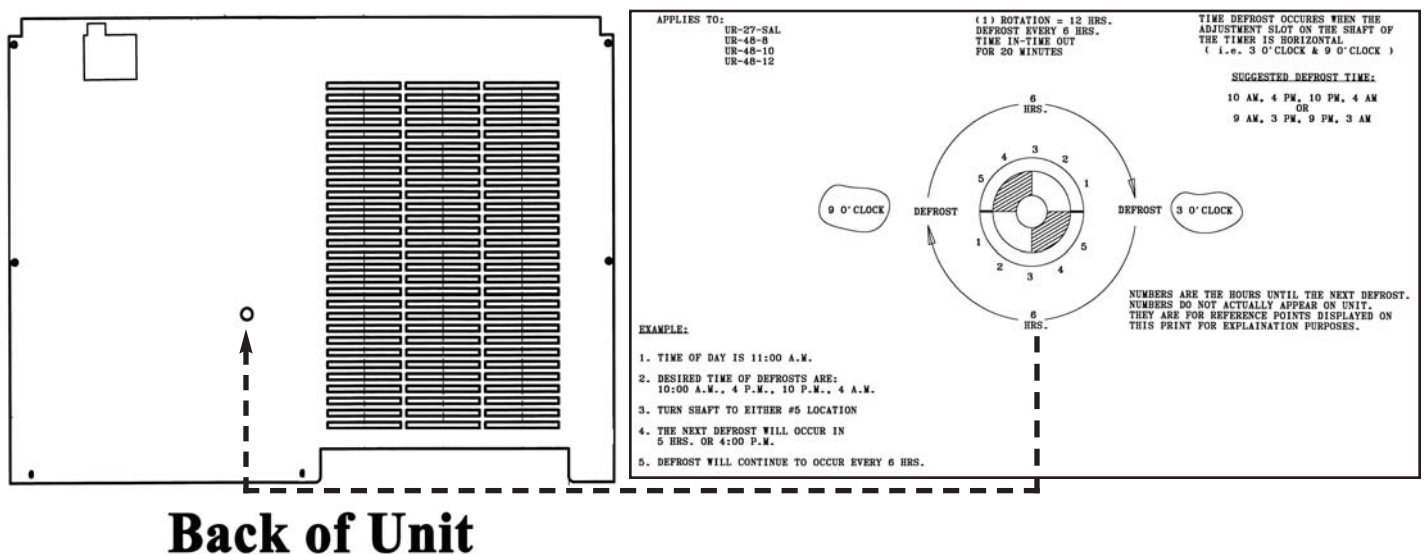

B. Thermometer Operation

The thermometer is located so that opening the door for even a brief period of time may cause the thermometer to indicate danger. The recover rate of the length of time required for the thermometer to indicate safe temperature is also rapid (usually a few minutes).

C. Important Operating Facts

Your new model is completely self-defrosting. Frost is automatically removed from concealed coil finned surfaces at predetermined intervals. All defrost condensate water is directed to a vaporizer pan and is disposed of automatically, no floor drain is required.

A fan motor circulates cold air throughout the fresh food and freezer storage compartments. This provides more uniform temperatures and very rapid recovery to proper operating temperatures after door opening, with its admission of warm room air.

The length of time required to remove the “heat” admitted due to prolonged or frequent door openings or the “heat” from a product load is dependent upon several factors. One is the amount of heat introduced into the cabinet due to duration and frequency of door openings; another is the temperature and size of the load being refrigerated. For example, placing a hot load of dough in a refrigerator will definitely cause the thermometer display to go into, and remain in, the danger zone for a prolonged period of time. This is normal and must be expected. However, you should be concerned if the thermometer indicates danger and the door(s) have NOT been opened or a warm product load has NOT been placed in the refrigerator. This may indicate a malfunction.

D. Food Pan Area

This is a “Food Holding” area only and is not approved for food storage. At the close of each work day, the food pans should be moved to a storage refrigerator. The pan area should be cleaned and left with empty pans and closed lid(s) . When loaded with +35°F cold product, the pans will maintain a temperature of +41°F or less for up to four (4) hours with the lid(s) open, as required by NSF (National Sanitation Foundation) in a +86°F ambient.

***Note:** Food products must be 1/2” or more below the top of the pan(s). NSF protocol is for 4” deep pans.

Continued use of this equipment will allow you to become familiar with its operation and functions.

SECTION 4 MAINTENANCE

A. Cleaning and Proper Detergent Use

Follow requirements of local health authorities.

1. Use a detergent-sanitizer or a mild detergent (neutral) or mildly alkaline (recommended for metal surfaces) followed by a sanitizing rinse solution. These chemicals are necessary to kill or deactivate the micro-organisms on the surface areas in contact with stored food. Choose these chemicals carefully. Some are toxic and should only be used on non-food surfaces.

CAUTION:

DO NOT USE ABRASIVE CLEANING SOLVENTS!!!!

Never scour any part of your refrigerator. Scouring powders or chemicals may cause damage by scratching or dulling the gleaming surface finish. Use alkaline, alkaline chlorinated or non-chloride cleaners.

2. Avoid cleaners containing quaternary salts as they also can attack stainless steel and cause pitting and rusting.
3. When using these products, it is important to follow label directions exactly to obtain the correct cleaning action.

B. Initial Cleaning of Cabinet

CAUTION:

DO NOT USE ABRASIVE CLEANING SOLVENTS!!!!

Prior to placing your new refrigerator into operation, it is advisable that the interior be washed thoroughly with a mild detergent and water solution. Rinse with clear water and a sanitizing solution. Allow cabinet to air dry.

C. Periodic Cleaning

It is more convenient to clean your refrigerator or storage freezer when the product load is at its lowest point.

1. Daily Exterior Surface Cleaning

Cleaning and sanitizing agents for stainless steel and aluminum exteriors should be used daily.

- a. Dip sponge in cleaning solution, wipe down surfaces.
- b. Polish with clean soft cloth. Wipe in direction of grain. Once a week a film cutting agent may be used for metal finishes to maintain a shining surface.

2. Weekly Interior Accessory Cleaning

It is recommended a minimum of once a week to maintain good sanitary conditions and to eliminate odors.

- a. Disconnect power by switching circuit breaker “OFF”, or removing power cord from receptacle.
- b. Remove all food to protective temporary storage.
- c. Open doors and allow warm room air to enter cabinet.
- d. Remove all accessories (shelves, racks, etc.) from within the cabinet and scrub with a detergent solution and a nylon bristled brush.
- e. Rinse with clear water.
- f. Soak in a final rinse of sanitizing solution for recommended period of time.
- g. Remove and air dry.

3. Weekly Interior Surface Cleaning

- a. When storage compartment(s) is sufficiently warm, remove all loose food particles.
- b. Scrub all interior surfaces with warm detergent solution 100°F - 120°F (38°C - 39°C) and a nylon bristled brush. Scrub the floor and ceiling surfaces of the interior walls, corners, inner door surface, gaskets, and latches.
- c. Rinse with warm clean water using a sponge.
- d. Remove excess rinse water with sponge.
- e. Rinse with clear water.

3. Weekly Interior Surface Cleaning (continued)

- f. Allow to air dry.
- g. Return accessories to unit.
- h. Return power (electric) to unit.
- i. Return food to cabinet when temperature indicator reaches safety zone.

4. Every Three Months, Condenser Maintenance

Cleaning is recommended at least once every three (3) months. However, once a month is recommended when unit is located near cooking equipment which produces grease laden vapors, i.e.: fryers, grills, steam kettles, etc.

- a. Disconnect power by switching circuit breaker to “OFF” position or removing power cord from receptacle.
- b. Use a vacuum cleaner with proper brush attachments to clean the condenser, compressor-motor and related parts.
- c. In extreme cases of dust and grease build-up, the condenser fins may require blowing out with compressed air.

Note: The air cooled condensing unit depends upon the amount of air passing through the condenser. Grease, lint and dust accumulation reduces required air flow. The refrigerator will consume less current and operate more efficiently if the condenser is kept clean.

WARNING:

*Failure to keep condenser clean may cause
premature failure of motor/compressor
which will NOT be covered by warranty!*

D. Lubrication

Unless otherwise specified, all Victory refrigerators are equipped with oilless type motors. The compressor motor is a sealed unit and is constantly being lubricated when in operation. The condenser and the evaporator motors are equipped with “Life-time” oiled bearings. These bearings are oiled at the factory and need never be oiled again.

NOTES

SECTION 5

TROUBLESHOOTING

TROUBLESHOOTING & SERVICING REFRIGERATION SYSTEM

PROBLEM	POSSIBLE CAUSE	REMEDY
1. Condensing unit fails to start - no hum.	<ol style="list-style-type: none"> Line disconnect switch open. Fuse removed or blown. Overload protector tripped. Control stuck in open position. Wiring improper or loose. 	<ol style="list-style-type: none"> Close start or disconnect switch. Replace fuse. Determine reason and correct/replace control. Repair or replace control. Check wiring against diagram.
2. Condensing unit fails to start - hums, but trips on overload protector.	<ol style="list-style-type: none"> Improperly wired. Low voltage to unit. Starting capacitor defective. Relay failing to close. Compressor motor has a winding open or shorted. Internal mechanical trouble in compressor. 	<ol style="list-style-type: none"> Check wiring against diagram. Determine reason and correct. Determine reason and replace. Determine reason and correct/replace if necessary. Replace compressor. Replace compressor.
3. Condensing unit starts, but fails to switch off of "start" winding.	<ol style="list-style-type: none"> Improperly wired. Low voltage to unit. Relay failing to open. Run capacitor defective. Excessively high discharge pressure. Compressor motor has a winding open or shorted. Internal mechanical trouble in compressor. 	<ol style="list-style-type: none"> Check wiring against diagram. Determine reason and correct. Determine reason and correct/replace if necessary. Determine reason and replace. Check discharge shut-off valve, possible overcharge, or insufficient cooling on condenser. Replace compressor. Replace compressor.
4. Condensing unit starts and runs, but short cycles on overload protector.	<ol style="list-style-type: none"> Additional current passing through overload protector. Low voltage to unit (or unbalanced if three phase.) Overload protector defective. Run capacitor defective. Excessive discharge pressure. Suction pressure too high. Compressor too hot - return gas. Compressor motor has a winding shorted. 	<ol style="list-style-type: none"> Check wiring diagram. Check for added fan motors, pumps, etc. connected to wrong side of protector. Determine reason and correct. Check current , replace protector. Determine reason and replace. Check ventilation, restrictions in cooling medium, restrictions in refrigeration system. For salad models, temperature control differential set to close-increase differential. Check refrigerant charge (fix leak) add if necessary. Replace compressor.
5. Condensing unit runs but short cycles on...	<ol style="list-style-type: none"> Overload protector. Thermostat. High pressure cut-out due to: <ol style="list-style-type: none"> Insufficient air or water supply. Overcharge. Air in system. Low pressure cut-out due to: <ol style="list-style-type: none"> Liquid line solenoid leaking. Compressor valve leak. Undercharge. Restriction in expansion device. 	<ol style="list-style-type: none"> See (4) above. Differential set too close - widen. <ol style="list-style-type: none"> Check air or water supply to condenser-correct. Reduce refrigerant charge. Purge. <ol style="list-style-type: none"> Replace. Replace. Fix leak, add refrigerant. Replace device.
6. Condensing unit operates for prolonged periods or continuously.	<ol style="list-style-type: none"> Shortage of refrigerant. Control contacts stuck or frozen closed. Excessive heat load placed into cabinet. Prolonged or too frequent door openings. Evaporator coil iced. Restriction in refrigeration system. Dirty condenser. Filter dirty. 	<ol style="list-style-type: none"> Fix leak, add charge. Clean contacts or replace control. Allow unit sufficient time for removal of latent heat. Plan or organize schedule to correct condition. Defrost. Determine location and remove. Clean condenser. Clean or replace.

TROUBLESHOOTING & SERVICING REFRIGERATION SYSTEM

PROBLEM	POSSIBLE CAUSE	REMEDY
7. Start capacitor open or shorted blown.	<ol style="list-style-type: none"> 1. Relay contacts not opening properly. 2. Prolonged operation on start cycle due to: <ol style="list-style-type: none"> a. Low voltage to unit. b. Improper relay. c. Starting load too high. 3. Excessive short cycling. 4. Improper capacitor. 	<ol style="list-style-type: none"> 1. Clean contacts or replace relay if necessary. 2. <ol style="list-style-type: none"> a. Determine reason and correct. b. Replace. c. Correct by using pump down arrangement if necessary. 3. Determine reason for short cycling (see 5 above) and correct. 4. Determine correct size and replace.
8. Run capacitor open, shorted or blown.	<ol style="list-style-type: none"> 1. Improper capacitor. 2. Excessively high line voltage (110% of rated-max.) 	<ol style="list-style-type: none"> 1. Determine correct size and replace. 2. Determine reason and correct.
9. Relay defective or burned out.	<ol style="list-style-type: none"> 1. Incorrect relay. 2. Incorrect mounting angle. 3. Line voltage too high or too low. 4. Excessive short cycling. 5. Relay being influenced by loose vibrating mounting. 6. Incorrect run capacitor. 	<ol style="list-style-type: none"> 1. Check and replace. 2. Remount relay in correct position. 3. Determine reason and correct. 4. Determine reason (see 5 above) and correct. 5. Remount rigidly. 6. Replace with proper capacitor.
10. Product zone temperature too high.	<ol style="list-style-type: none"> 1. Control setting too high. 2. Inadequate air circulation. 	<ol style="list-style-type: none"> 1. Reset control. 2. Rearrange product load to improve air circulation.
11. Suction line frosted or sweating.	<ol style="list-style-type: none"> 1. Overcharge of refrigerant. 2. Evaporator fan not running. 3. If remote model, expansion valve stuck open. 4. If remote model expansion valve is passing excess refrigerant or is oversized. 	<ol style="list-style-type: none"> 1. Correct charge. 2. Determine reason and correct. 3. Clean valve of foreign particles. Replace if necessary. 4. Readjust valve or replace with smaller valve.
12. Liquid line frosted or sweating.	<ol style="list-style-type: none"> 1. Restriction in dehydrator or strainer. 2. Liquid shut-off (king valve) partially closed. 	<ol style="list-style-type: none"> 1. Replace part. 2. Open valve fully.
13. Noisy condensing unit.	<ol style="list-style-type: none"> 1. Loose parts or mounting. 2. Tubing rattle. 3. Bent fan blade causing vibration. 4. Fan motor bearings worn. 	<ol style="list-style-type: none"> 1. Find and tighten. 2. Reform to be free of contact. 3. Replace blade. 4. Replace motor.

“End Of Section, Click Here For Table Of Contents”

NOTES

SECTION 6 PARTS LIST

	Page
Compact Undercounter Refrigerators and Freezers.....	18-21
Compact Undercounter Refrigerator Salad/Sandwich Units.....	22-24
V - Line Big Top Salad/Sandwich Refrigerators.....	25-26
V - Line Pizza Prep Tables.....	27-28

Replacement Parts

Compact Undercounter Refrigerators & Freezers

Part No.	Description	UR-27	UR-48	UF-27	UF-48
	<u>Refrigeration Components</u>				
50629701	Coil, Evaporator (63F16)	X	X	X	X
50180701	Accumulator, 1/2" Ports Suction Line	X	X	X	X
50785501	Drier, Filter	X	X	X	X
50783501	Compressor 1/5 h.p. R-134A	X	X		
50788101	Compressor 1/3 h.p. R-404A			X	X
10708801	Heat Exchanger AssemblyX	X			
10719201	Heat Exchanger Assembly		X	X	
50785601	Coil, Condenser (63C12)	X	X	X	X
50639801	Fan Motor, Condenser	X	X	X	X
50602602	Fan Blade, Condenser	X	X	X	X
10708503	Fan & Coil Assembly, Condenser			X	X
10708504	Fan & Coil Assembly, Condenser	X	X		
04433101	Bracket, Condenser Fan	X	X	X	X
10708701	Coil, Evaporator Assembly, R-134A	X	X		
10719001	Coil, Evaporator Assembly, R-404A			X	X
44131501	Evaporator Fan Panel Assembly	X		X	
44131502	Evaporator Fan Panel Assembly		X		X
10708401	Evaporator Fan Assembly	X	X		
10708404	Evaporator Fan Assembly			X	X
50639801	Fan Motor, Evaporator	X	X	X	X
50602603	Fan Blade, Evaporator	X	X	X	X
04119901	Bracket, Evaporator Fan	X	X	X	X
50625701	Guard, Fan	X	X	X	X
50198901	Capillary Tube 10' x .036 R-404A			X	X
50199101	Capillary Tube 10' x .049 R-134A	X	X		
50654101	Condensate Drain Pan	X	X	X	X
50616101	Temperature Control, Freezer			X	X
50616201	Temperature Control, Refrigerator	X	X		
50569502	Thermometer, Hanging Stem	X	X	X	X
	<u>Electrical Components</u>				
50631501	Heater, Evaporator Coil Defrost (115V, 200W)			X	X
50518901	Heater, Center Mullion		X		X
50636401	Timer, Defrost			X	X
50632701	Electric Harness (Power Cord & Plug Assembly)	X	X		
50657001	Electric Harness (Power Cord & Plug Assembly)			X	X
50636201	Safety, Defrost Limit			X	X

Replacement Parts

Compact Undercounter Refrigerators & Freezers

Part No.	Description	UR-27	UR-48	UF-27	UF-48
	<u>Doors & Components</u>				
55113501	Door Assembly, RH	X		X	
55113502	Door Assembly, LH	X		X	
55113601	Door Assembly, RH		X		X
55113602	Door Assembly, LH		X		X
55114401	Door Assembly with Locks, RH	X		X	
55114402	Door Assembly with Locks, LH	X		X	
55114403	Door Assembly with Locks, RH		X		X
55114404	Door Assembly with Locks, LH		X		X
55113505	Door Assembly with Dial Thermometer, RH	X		X	
55113506	Door Assembly with Dial Thermometer, LH	X		X	
55115001	Latch Assembly	X		X	
50630601	Gasket	X		X	
50630602	Gasket		X		X
50635201	Gasket Retainer, Door Sides	X	X	X	X
50635202	Gasket Retainer, Top & Bottom	X		X	
50635203	Gasket Retainer, Top & Bottom		X		X
50635301	Liner, Inner Door	X		X	
50635302	Liner, Inner Door		X		X
	<u>Drawers & Components (URD 27's)</u>				
55113703	Drawer Assembly, Lower	X			
55113704	Drawer Assembly, Upper	X			
50630603	Gasket, Drawer (Product)	X			
50635202	Gasket, Retainer, Drawer, Top & Bottom	X			
50635201	Gasket, Retainer, Drawer, Side	X			
50714801	Pan, Drawer (12 x 20 x 6)	X			
50635303	Pan, Drawer	X			
55113901	Front Assembly, Drawer	X			
55114701	Track, Drawer Slide, Right	X			
55114702	Track, Drawer Slide, Left	X			
05109902	Channel, Slide Support	X			
55114303	Slide Support Assembly with Rollers, Left	X			
55114304	Slide Support Assembly with Rollers, Right	X			
50543803	Roller Bearing, Slide Support	X			
09145901	Bracket, Drawer Slide Lower Front, Left	X			
09145902	Bracket, Drawer Slide Lower Front, Right	X			
09146001	Bracket, Drawer Slide Upper Front, Left	X			
09146002	Bracket, Drawer Slide Upper Front, Right	X			

Replacement Parts

Compact Undercounter Refrigerators & Freezers

Part No.	Description	UR-27	UR-48	UF-27	UF-48
<u>Drawers & Components cont'd</u>					
09146101	Bracket, Drawer Slide Lower Rear, Left	X			
09146102	Bracket, Drawer Slide Lower Rear, Right	X			
09146201	Bracket, Drawer Slide Upper Rear, Left	X			
09146202	Bracket, Drawer Slide Upper Rear, Right	X			
<u>Hardware</u>					
99147201	Hinge Kit Assembly, Upper	X	X	X	X
99147301	Hinge Kit Assembly, Lower	X	X	X	X
50621901	Bushing, Nylon, Hinge Bracket	X	X	X	X
50641801	Spacer, Hinge with Screws	X	X	X	X
50651102	Handle, Door	X	X	X	X
50586002	Leg, Stainless Steel	X	X	X	X
50671801	Leg, Black	X	X	X	X
50096002	Caster, Swivel 5" with Brake	X	X	X	X
50648301	Caster, Swivel 3" with Brake (Front)	X	X	X	X
50648302	Caster, Swivel 3" without Brake (Rear)	X	X	X	X
50642201	Caster, 1 1/4" Mighty Mite	X	X	X	X
50648305	Caster, 2 1/2" with Brake (Front)	X	X	X	X
50648306	Caster, 2 1/2" without Brake (Rear)	X	X	X	X
50703101	Heli Coil Insert (used with part number 50642201)	X	X	X	X
11115101	Leg Brace, Front	X		X	
11115102	Leg Brace, Front		X		X
10714101	Leg Brace, Rear	X		X	
10714102	Leg Brace, Rear		X		X
<u>Shelves</u>					
50631602	Shelf, Wire Type	X		X	
50631701	Shelf, Wire Type		X		X
50022501	Clip, Shelf		X		X
33110201	Support, Shelf Front		X		X
33110301	Support, Shelf Rear		X		X
<u>Cabinet, Miscellaneous</u>					
50736401	Victory Logo, Plastic	X	X	X	X
50736501	Nameplate, "Victory" Refrigerator	X	X		
50736502	Nameplate, "Victory" Freezer			X	X
09144801	Scrap Receptacle, Front	X	X	X	X
09144901	Scrap Receptacle, Rear	X	X	X	X

Replacement Parts

Compact Undercounter Refrigerators & Freezers

Part No.	Description	UR-27	UR-48	UF-27	UF-48
	<u>Cabinet, Miscellaneous cont'd</u>				
06116007	Back Panel, Galvanized (Top)	X	X	X	X
06116008	Back Panel, Galvanized (Bottom)	X	X	X	X
06116009	Back Panel, Galvanized (Left)		X		X

Replacement Parts

Compact Undercounter Refrigerator Sandwich/Salad Units

Part No.	Description	UR-27-SALA	UR-48-8A	UR-48-10A	UR-48-12A
	<u>Refrigeration Components</u>				
50629701	Coil, Evaporator (63F16)	X	X	X	X
50180701	Accumulator, 1/2" Ports Suction Line	X	X	X	X
50785501	Drier, Filter	X	X	X	X
50783501	Compressor 1/5 h.p. R-134A	X	X	X	X
10708801	Heat Exchanger AssemblyX	X	X	X	
50785601	Coil, Condenser (63C12)	X	X	X	X
50639801	Fan Motor, Condenser	X	X	X	X
50602602	Fan Blade, Condenser	X	X	X	X
10708504	Fan Assembly, Condenser	X	X	X	X
04433101	Bracket, Condenser Fan	X	X	X	X
10708701	Coil, Evaporator Assembly R-134A	X	X	X	X
10792101	Evaporator Fan Assembly		X	X	X
10792012	Evaporator Fan Assembly	X			
50639801	Fan Motor, Evaporator	X	X	X	X
50602603	Fan Blade, Evaporator	X			
50830501	Fan Blade, Evaporator (White in Color)		X	X	X
50830502	Fan Blade, Evaporator (Gray in Color)		X	X	X
50625701	Guard, Fan	X	X	X	X
50199101	Capillary Tube 10' x .049 R-134A	X	X	X	X
04454301	Condensate Drain Pan	X	X	X	X
50181402	Temperature Control, Refrigerator	X	X	X	X
50569502	Thermometer, Hanging Stem	X	X	X	X
	<u>Electrical Components</u>				
50518901	Heater, Center Mullion		X	X	X
50744804	Timer, Defrost (for 20 minute shutdown period)	X	X	X	X
50833601	Electric Harness (Power Cord & Plug Assembly)	X	X	X	X
50836101	Harness, Evaporator Fan Wire		X	X	X

*Note: The defrost timer shown on this parts list is not for an actual defrost cycle, but to assist in the twenty (20) minute shutdown period every six (6) hours!!!!

Replacement Parts

Compact Undercounter Refrigerator Sandwich/Salad Units

Part No.	Description	UR-27-SALA	UR-48-8A	UR-48-10A	UR-48-12A
<u>Doors & Components</u>					
55113501	Door Assembly, RH	X			
55113502	Door Assembly, LH	X			
55113601	Door Assembly, RH		X	X	X
55113602	Door Assembly, LH		X	X	X
55114401	Door Assembly with Locks, RH	X			
55114402	Door Assembly with Locks, LH	X			
55114403	Door Assembly with Locks, RH		X	X	X
55114404	Door Assembly with Locks, LH		X	X	X
55113505	Door Assembly with Dial Thermometer, RH	X			
55113506	Door Assembly with Dial Thermometer, LH	X			
55115001	Latch Assembly	X			
50630601	Gasket, Door	X			
50630602	Gasket, Door		X	X	X
50635201	Gasket Retainer, Door Sides	X	X	X	X
50635202	Gasket Retainer, Top or Bottom	X			
50635203	Gasket Retainer, Top or Bottom		X	X	X
50635301	Liner, Inner Door	X			
50635302	Liner, Inner Door		X	X	X
<u>Hardware</u>					
99147201	Hinge Kit Assembly, Upper	X	X	X	X
99147301	Hinge Kit Assembly, Lower	X	X	X	X
50621901	Bushing, Nylon, Hinge Bracket	X	X	X	X
50641801	Spacer, Hinge with Screws	X	X	X	X
50651102	Handle, Door	X	X	X	X
50586002	Leg, Stainless Steel	X	X	X	X
50671801	Leg, Black	X	X	X	X
50096002	Caster, Swivel 5" with Brake	X	X	X	X
50648301	Caster, Swivel 3" with Brake (Front)	X	X	X	X
50648302	Caster, Swivel 3" without Brake (Rear)	X	X	X	X
50642201	Caster, 1 1/4" Mighty Mite	X	X	X	X
50648305	Caster, 2 1/2" with Brake (Front)	X	X	X	X
50648306	Caster, 2 1/2" without Brake (Rear)	X	X	X	X
50703101	Heli Coil Insert (used with part number 50642201)	X	X	X	X
11115101	Leg Brace, Front	X			
11115102	Leg Brace, Front		X	X	X
10714101	Leg Brace, Rear	X			
10714102	Leg Brace, Rear		X	X	X

Replacement Parts

Compact Undercounter Refrigerator Sandwich/Salad Units

Part No.	Description	UR-27-SALA	UR-48-8A	UR-48-10A	UR-48-12A
	<u>Shelves</u>				
50631602	Shelf, Wire Type	X			
50631701	Shelf, Wire Type		X	X	X
50022501	Clip, Shelf		X	X	X
33110201	Support, Shelf Front		X	X	X
33110301	Support, Shelf Rear		X	X	X
	<u>Cabinet, Miscellaneous</u>				
50736401	"Victory" Logo, Plastic	X	X	X	X
50736501	Nameplate, "Victory" Refrigerator	X	X	X	X
50621101	Pin, Cutting Board	X	X	X	X
50830401	Cutting Board		X	X	X
50830403	Cutting Board	X			
10803601	Hinged Lid Assembly				X
10803602	Hinged Lid Assembly			X	
10803603	Hinged Lid Assembly		X		
10803604	Hinged Lid Assembly	X			
50632001	Handle, Lid with Screws	X	X	X	X
10804001	Assembly, Case Top				X
10804101	Assembly, Case Top			X	
10804201	Assembly, Case Top		X		
10804301	Assembly, Case Top	X			
10803701	Back Cover Assembly				X
10803702	Back Cover Assembly			X	
10803703	Back Cover Assembly		X		
10803704	Back Cover Assembly	X			
06116008	Back Panel, Galvanized (Bottom)	X	X	X	X
01378401	Back Panel, Galvanized (Left)		X	X	X
01379301	Back Panel, Galvanized (Top)	X	X	X	X
	<u>Pan Supports</u>				
09349701	Pan Support Bar		X	X	X
09349702	Pan Support Bar	X			
50700601	Pan, Food Storage 1/6	X	X	X	X
50700602	Pan, Food Storage 1/9	X			
01379201	Hood, Hinged				X
01379001	Hood, Hinged			X	
01378801	Hood, Hinged		X		
01378601	Hood, Hinged	X			

"End Of Section, Click Here For Table Of Contents"

Replacement Parts

V - Line Big Top Salad / Sandwich Refrigerators

Part No.	Description	UR-3	UR-4	UR-5
	<u>Refrigeration Components</u>			
50749901	Coil, Evaporator (2 x 5 x 14)	X		
50750001	Coil, Evaporator (2 x 5 x 18)		X	X
50750101	Fan Motor, Evaporator	X	X	X
50750201	Fan Blade, Evaporator	X	X	X
50750301	Coil, Condenser	X	X	X
50750401	Fan Motor, Condenser	X	X	X
50750501	Fan Blade, Condenser	X		
50750601	Fan Blade, Condenser		X	X
50750701	Capillary Tube 6' x .031	X		
50750801	Capillary Tube 10' x .042		X	
50750901	Capillary Tube 8 1/2' x .042			X
50751001	Filter Drier	X	X	X
50751101	Temperature Control	X	X	X
50569502	Thermometer	X	X	X
50751201	Compressor Aspera 1/5 h.p. R-22	X		
50751301	Compressor Aspera 1/4 h.p. R-22		X	X
	<u>Doors & Components</u>			
50751401	Door Assembly, RH	X		X
50751501	Door Assembly, LH		X	
50751601	Door Assembly, RH		X	
50751701	Door Assembly, LH			X
50751801	Gasket, Door	X		X
50751901	Gasket, Door		X	
10685101	Hinge Assembly, Door	X	X	X
50752101	Handle, Door	X	X	X
	<u>Divider Bars</u>			
50834901	Divider Bar, Horizontal		X	
50819502	Divider Bar, Vertical			X

Replacement Parts

V - Line Big Top Salad / Sandwich Refrigerators

Part No.	Description	UR-3	UR-4	UR-5
	<u>Shelves</u>			
50752201	Shelf with Four (4) Clips	X		
50752301	Shelf with Four (4) Clips		X	
50752401	Shelf with Four (4) Clips			X
50768402	Clip, Shelf	X	X	X
50762101	Pilaster (w/ 2 accessory screws part no. 50257101)	X	X	X
	<u>Cabinet, Miscellaneous</u>			
50096002	Casters	X	X	X
50671801	Legs, Black	X	X	X
50586002	Legs, Stainless Steel	X	X	X
50801901	End Panel, Glue On		X	
50752601	Cutting Board 12" x 30 1/2"	X		
50752602	Cutting Board 12" x 46 1/2"		X	
50752603	Cutting Board 12" x 61"			X
50632501	Pan, Food Storage 1/6 Size	X	X	X
50766001	Hood UR-3, UR-4, & UR-5-24	X	X	X
50766101	Hood UR-4-18 & UR-5-18		X	X
50766201	Roll Cover UR-3, UR-4-12 & UR-5-24	X	X	X
50766301	Roll Cover UR-3, UR-4-18 & UR-5-18	X	X	X

Replacement Parts

V - Line Pizza Prep Tables

Part No.	Description	PT-40	PT-64	PT-88
<u>Refrigeration Components</u>				
50752901	Coil, Evaporator (4 x 7 x 14 1/2)	X	X	X
50750101	Fan Motor, Evaporator	X	X	X
50750201	Fan Blade, Evaporator	X	X	X
50753001	Fan Motor, Condenser	X	X	X
50753101	Fan Blade, Condenser	X		
50753201	Fan Blade, Condenser		X	X
50750801	Capillary Tube 10' x .042	X		
50750901	Capillary Tube 8 1/2' x .042		X	
50753301	Capillary Tube 9' x .049			X
50751001	Filter Drier	X	X	X
50751101	Temperature Control	X	X	X
50569502	Thermometer	X	X	X
50753401	Compressor, Aspera 1/4 h.p. R-22	X		
50753501	Compressor, Aspera 1/3 h.p. R-22		X	
50753601	Compressor, Aspera or Tecumseh R-22			X
<u>Doors & Components</u>				
50753701	Door Assembly, RH	X	X	X
50753801	Door Assembly, LH		X	X
50753901	Gasket, Door	X	X	X
10685101	Hinge Assembly, Door	X	X	X
50752101	Handle, Door	X	X	X
<u>Shelves</u>				
50754001	Shelf with Four (4) Clips	X		
50754101	Shelf with Four (4) Clips		X	X
50768402	Clip, Shelf	X	X	X
50762101	Pilaster (w/ 2 accessory screws part no. 50257101)	X	X	X
<u>Cabinet, Miscellaneous</u>				
50096002	Casters	X	X	X
50671801	Leg, Black	X	X	X
50586002	Leg, Stainless Steel	X	X	X

Replacement Parts

V - Line Pizza Prep Tables

Part No.	Description	PT-40	PT-64	PT-88
	<u>Cabinet, Miscellaneous cont'd</u>			
50754201	Cutting Board 20" x 40"	X		
50754202	Cutting Board 20" x 64"		X	
50754203	Cutting Board 20" x 88"			X
50755501	Garnish Rack	X	X	X
50755502	Rubber Boot, Garnish Rack	X	X	X
50766401	Lid with Handle	X		
50766501	Lid with Handle (Outer Section PT-88)		X	X
50766601	Lid with Handle (Center Section PT-88)			X
50767001	Lid Brackets & Pin Set	X	X	X
50767201	Lid Handle, 4"	X	X	X
50804201	Lid Bumper (Rubber)	X	X	X
50804301	Wall Bumper (Rubber)	X	X	X
50804701	Drawer Slide Kit			X
50804801	Roller (Drawer Model)			X

SECTION 7 SCHEMATICS

COMPACT UNDERCOUNTER REFRIGERATOR FOR MODELS: UR-27 & UR-48 115V, 60HZ

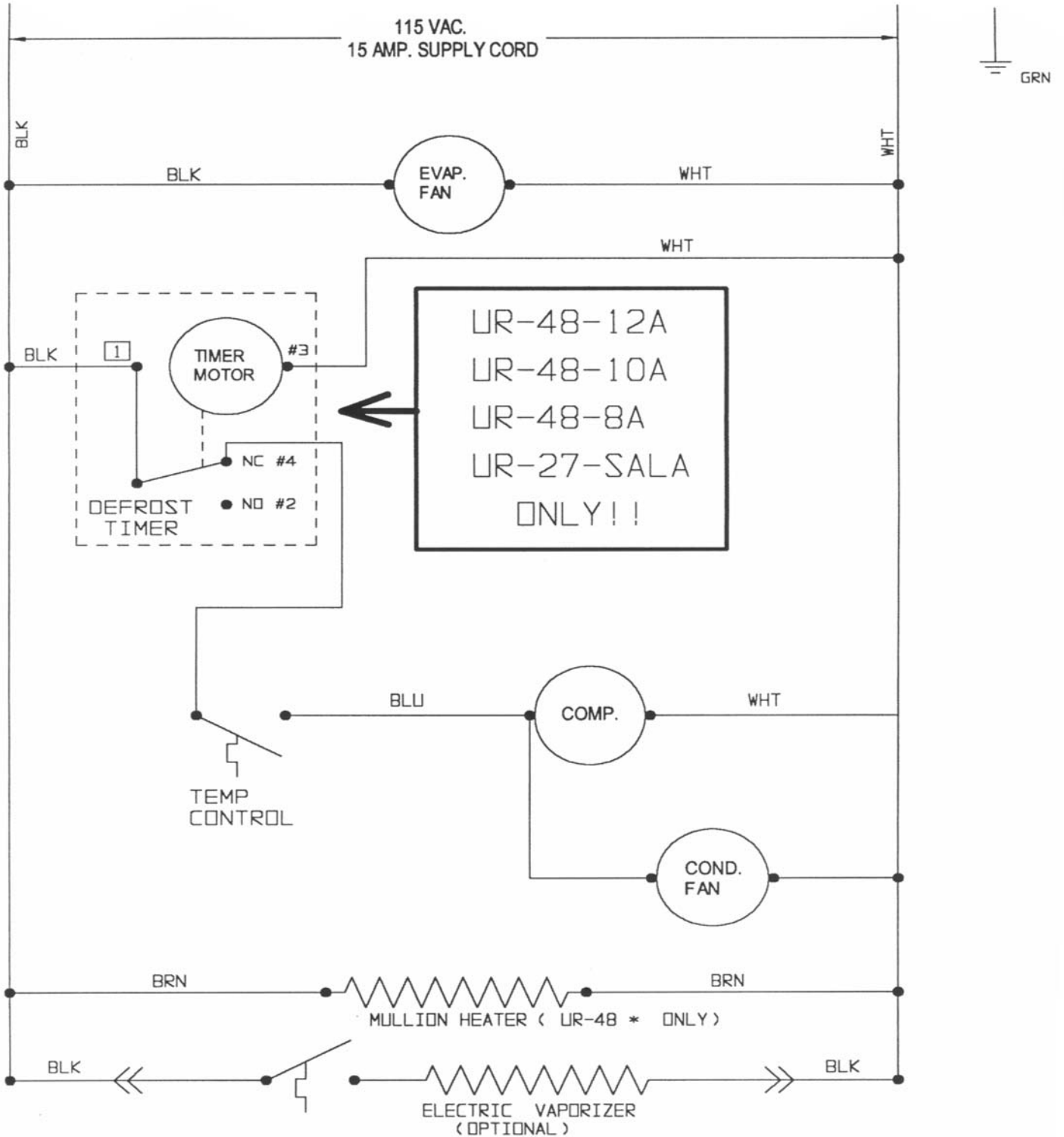

COMPACT UNDERCOUNTER FREEZER FOR MODELS: UF-27 & UF-48 115V, 60HZ

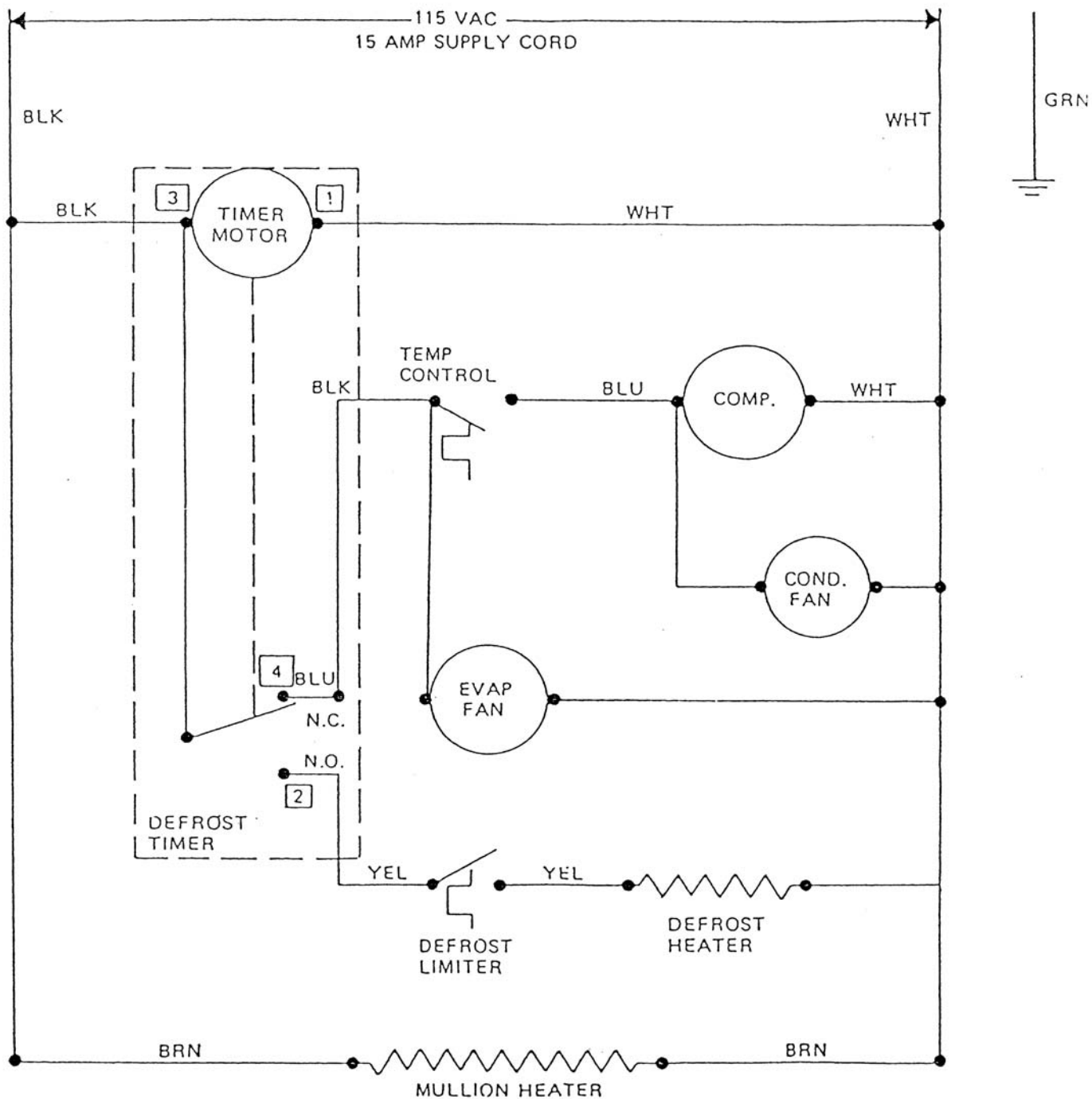

V-LINE BIG TOP SALAD/SANDWICH REFRIGERATOR

FOR MODELS: UR-3, UR-4, & UR-5

115V, 60HZ

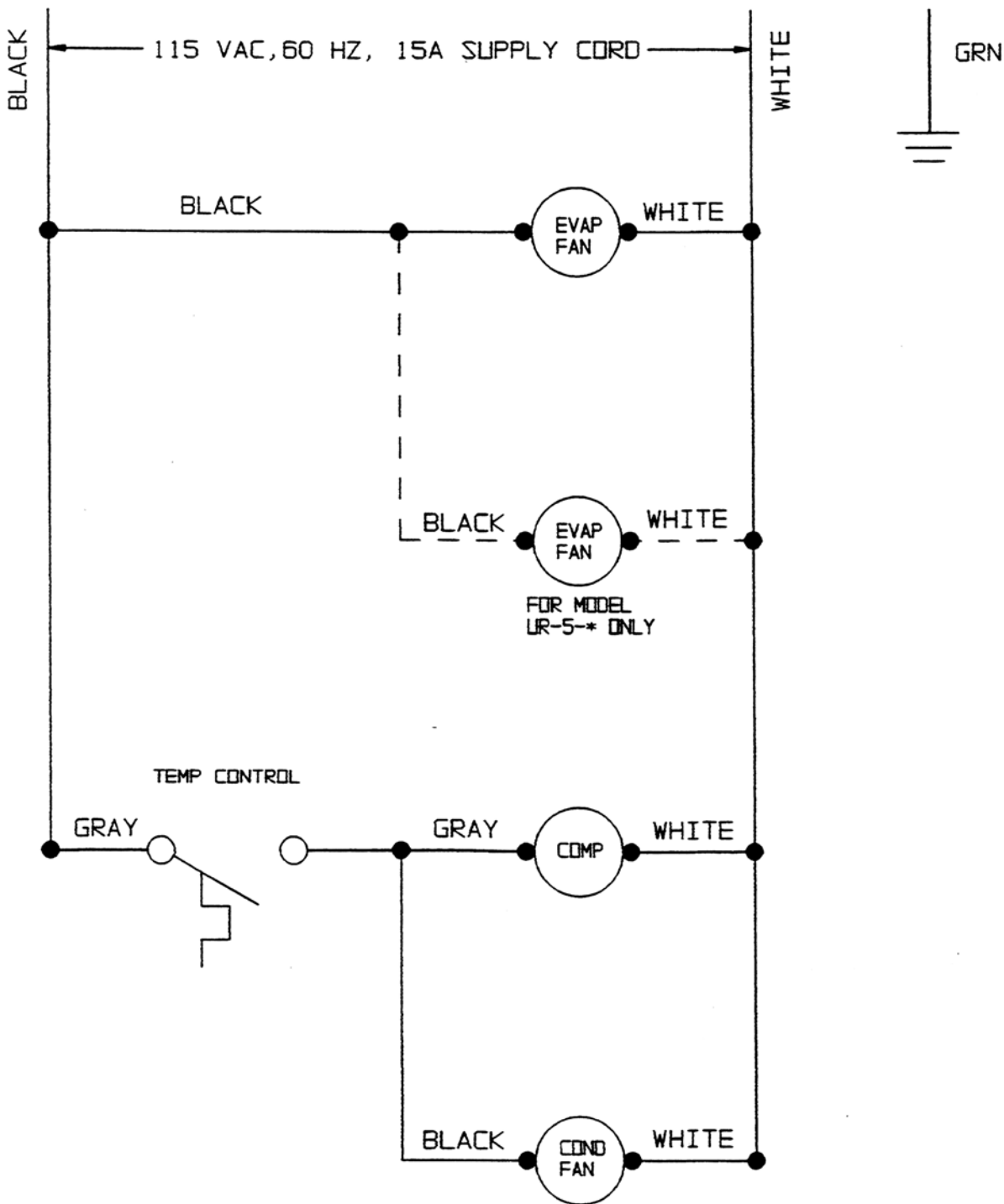

V-LINE PIZZA PREP TABLE FOR MODELS: PT-40, PT-64, & PT-88 115V, 60HZ

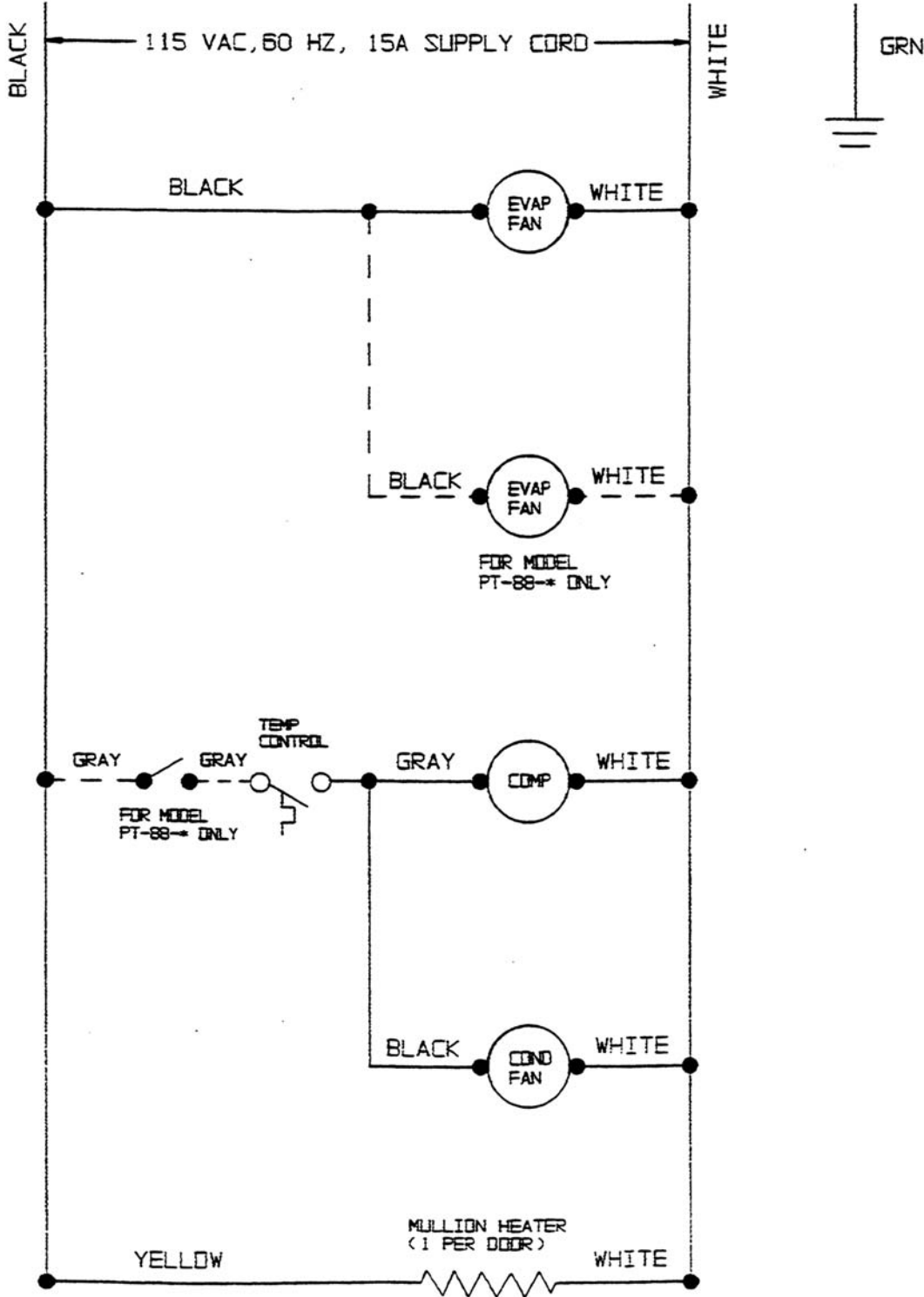



VICTORY REFRIGERATION
110 Woodcrest Road
Cherry Hill, NJ 08003

Phone (856) 428-4200 Fax (856) 428-7299

Website: www.victory-refrig.com

E-Mail: parts@victory-refrig.com

parts.order-entry@victory-refrig.com

or

service@victory-refrig.com

Manual Part Number: 50647203

Rev: 03

Print Date: 11/5/01

Price: \$15.00



AGA FOODSERVICE EQUIPMENT

Website: www.agafoodservice.com