

# On-Counter Blending Station<sup>®</sup> MP

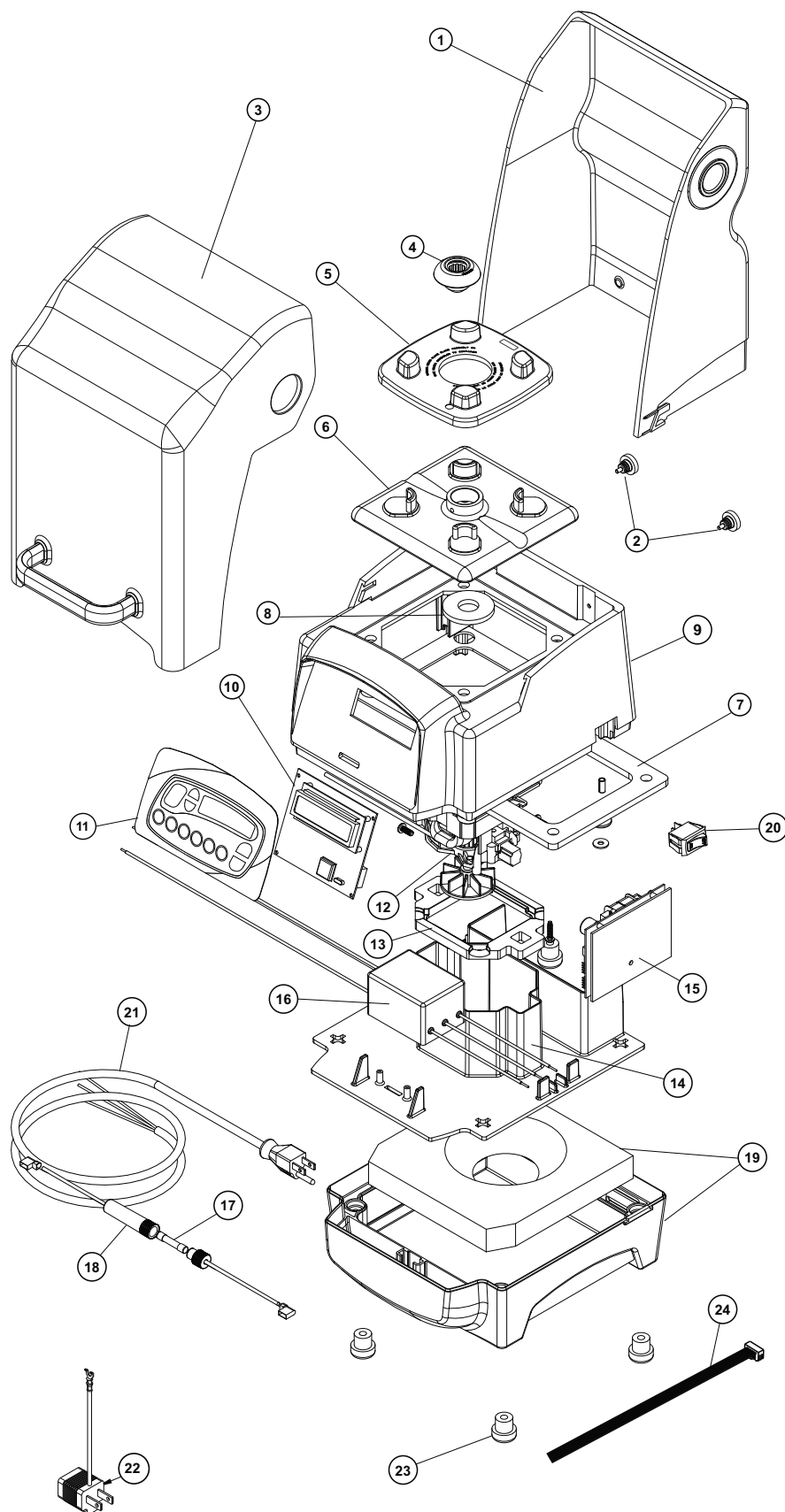

# On-Counter Blending Station® MP Parts List – 100V (Japan), 120V, 120V (Taiwan), 220/240V

NO.	NEW PART NO.	OLD PART NO.	DESCRIPTION	VOLTAGE	QTY./PACK
1	18008	18008	Compact Back Cover only	All	1
2	18005	18005	Thumbscrews for Back Cover (2)	All	2
3	18007	18007	Compact Door Cover only	All	1
4	891	891	Drive Socket Assembly	All	1
4	15546	15546	Drive Socket Assembly (Set of 2)	All	2
4	15547	15547	Drive Socket Assembly (Set of 5)	All	5
5	15579	15579	XP Centering Pad	All	1
6	15771	CST105	Top Motor Plate	All	1
7	15772	FOM164	Thick Top Motor Plate Gasket	All	1
8	15773	FOM163	Donut Gasket	All	1
9	15774	PLS160	On-Counter Upper Housing	All	1
10	15799	ASY162	Low Voltage Board Assembly (includes Memory Cable)	All	1
11	15800	LBL414	On-Counter Touch Pad Wrap Label	All	1
11	15777	CTL160	On-Counter Touch Pad	All	1
12	15685	ASY200	Motor Assembly 3 HP	220/240V	1
12	15681	ASY198	Motor Assembly 3 HP	100/120V	1
13	15778	FOM161	Motor Gasket	All	1
14	15779	PLS164	Motor Shroud	All	1
15	15780	CTL173	High Voltage Board Assembly	120/220/240V	1
15	15781	CTL170	High Voltage Board Assembly	100V	1
16	15739	CTL509	EMI Filter	220/240V	1
17	15782	CTL172	8 Amp Fuse	220/240V	1
18	15783	ASY165	Fuse Holder	220/240V	1
19	15784	ASY160	On-Counter Lower Housing	All	1
20	15785	CTL805	On/Off Rocker Switch	220/240V	1
20	15786	CTL800	On/Off Rocker Switch	100/120V	1
21	By Country	By Country	Power Cord	220/240V	1
21	15787	PLG134	Power Cord	100/120V	1
22	15745	CTL125	Japanese Adapter	100V	1
23	794	794	Rubber Feet (4)	All	4
24	15746	n/a	Memory Cable	All	1