



FOODSERVICE

Owner's Manual

Read And Save These Instructions



Blending Station[®] MP

Maximum Performance
Commercial Blender

All Models

IMPORTANT SAFEGUARDS

1. Read all instructions.
2. To protect against risk of electrical shock, do not put motor base in water or other liquid.
3. Close adult supervision is necessary when machine is used by or near children.
4. Unplug the power cord from the wall outlet when the Vita-Mix® machine is not in use, before disassembling, when putting on or taking off parts, and before cleaning, other than washing the container.
5. Never contact moving parts, especially the blades.
6. Do not operate any machine with a damaged cord or plug, if the machine malfunctions, or has been dropped or damaged in any manner. In the US and Canada, call **Vita-Mix Technical Support, 800-886-5235** at once for examination, repair, possible replacement, or electrical or mechanical adjustment. If you live outside the United States or Canada, contact your local Vita-Mix Distributor, or telephone the Vita-Mix International Division at +1.440.782.2450 or email international@vitamix.com for a distributor in your country.
7. Do not use attachments not recommended or sold by Vita-Mix Corporation. Doing so will void the warranty. **Alteration or modification of this product in any form is not recommended as such may result in bodily injury.**
8. **Do not use outdoors.**
9. Do not let the power cord hang over edge of table or counter.
10. Do not place the machine on or near a hot gas or electrical burner, in a heated oven, or allow machine to touch hot surfaces. External heat sources can damage the machine.
11. Keep hands and utensils out of container while motor is running to prevent the possibility of severe personal injury and/or damage to the Vita-Mix machine. A rubber spatula may be used, but only when the Vita-Mix machine is not running.
12. **WARNING: Blade is sharp. Handle carefully.**
 - Never try to remove blade while container is sitting on the motor base.
 - Do not operate with loose, nicked or damaged blade – replace immediately.
 - To reduce the risk of personal injury, never place blade assembly on motor base without blender container properly attached.

13. The maximum normal load is equivalent to the ounces (liters) listed on the container, i.e., 48 oz. / 1.4 Ltr., and substantially less with thick mixtures.
14. Always operate the Vita-Mix machine with a lid in place.
15. Display window area will scratch when contacted with a scouring pad or sharp object. Use a soft cloth to wipe the control panel area clean.
16. The Blending Station cannot be cleaned with a water jet.
17. It is recommended that for a 120 VAC unit installation, you have at least one 20 amp outlet per machine, available within 6 ft. / 1.8 m of the Blending Station. 220 VAC and 100 VAC units require a dedicated line.
Consult an electrician for proper electrical needs.
18. **CAUTION:** Turn power OFF or unplug the machine before touching movable parts. Shut OFF power switch at night or whenever machine will be left unattended.

SAVE THESE INSTRUCTIONS

Enjoy the safety of this grounded machine. The Vita-Mix blender's U.S. power cord comes equipped with a three-prong (grounding) plug which mates with a standard three-prong wall outlet (Figure A). **This cord will vary for countries outside the United States.**

Adapters (Figure B) are available for two-prong outlets. Do not cut or remove the third (ground) prong from the plug or power cord.

Consult your electrician if you are not sure if the wall outlet is grounded through the building wiring. With a properly grounded two-prong wall outlet, ground the machine by attaching the tab on the adapter to the wall outlet cover by means of the screw in the center of the cover (Figure B).



**THREE PRONG
ADAPTERS ARE
NOT TO BE USED
IN CANADA.**

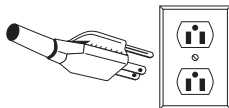

Figure A

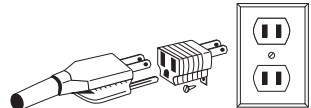
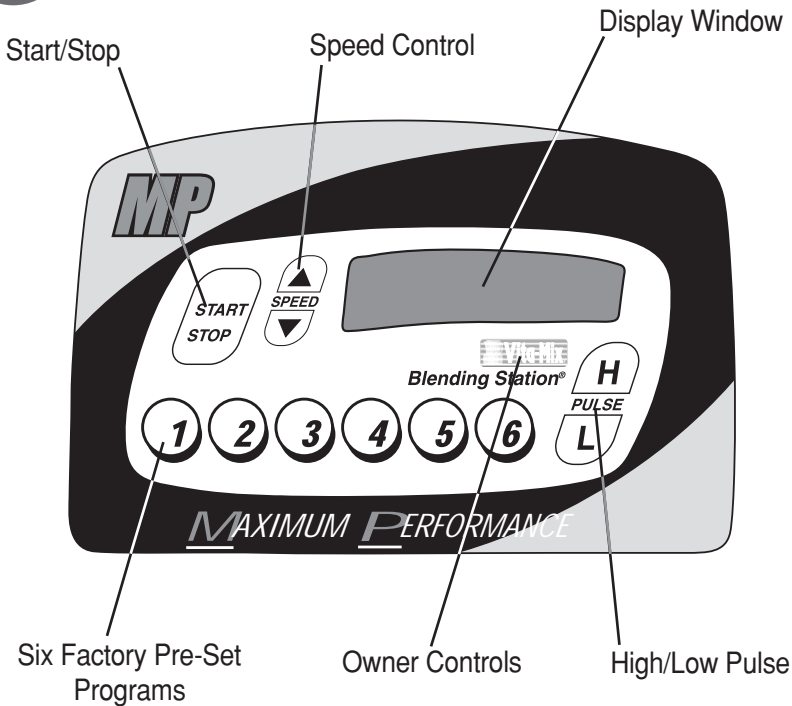

Figure B

Control Panel



Blending Station® MP

ON/OFF Power Switch - Located on the side of the motor base, the ON/OFF switch controls the power to the machine. While plugged in, switch to ON to ready the machine for blending. Shut OFF the power switch at night or whenever the machine will be left unattended.

START/STOP Button - Pressing START/STOP once *starts* and *runs* the machine and turns the blade. Press the START/STOP button again to *stop* the machine and the blade. **NOTE:** Pressing one of the PRE-SET PROGRAM buttons, while the motor is running, will also stop the machine.

SPEED CONTROL Button - Press the ▲ button to gradually *increase* the speed of the blade in increments of 1%, up to 100%. Press the ▼ button to gradually *decrease* the speed of the blade in increments of 1%, down to 7%. SPEED CONTROL is used to set the blending speed of the PULSE buttons (see Instructions, page 15) and the START/STOP button (see Instructions, pages 15-16). **NOTE:** These settings will reset if the power is shut off.

PRE-SET PROGRAM Buttons - These buttons, numbered 1 thru 6, are pre-programmed blending cycles designed for the most commonly made drinks. Depending on the viscosity of the drink you are creating, pressing one of the six PRE-SET PROGRAM buttons will run the machine for a full cycle. The machine will stop by itself when the cycle is complete. A cycle varies in speed and length; see the Instructions on page 14 for a complete description of the range of each PRE-SET button. See page 6 for information on Custom Programming these six buttons. Due to the difference of recipes, your results may vary.

DISPLAY WINDOW - This area, depending on which button is pressed, displays a variety of operation messages. A “READY” message appears when there is power to the machine.

OWNER CONTROLS - A control panel accessible by pressing the Vita-Mix logo.



- **Press once** to reveal the mode message. Press button 1 then 6 within five seconds to continue. Once the correct code is entered, the display will indicate the motor temperature (NORM, WARM, HOT), a usage count and a total. The “COUNT” is a machine usage total and can be reset. This can be used to keep a count of the number of drinks sold in a week, day or even an hour. To clear, press and hold the START/STOP button for 5 seconds. The “TOTAL” keeps track of the machine usage, including production and testing, and cannot be cleared.
- **Press twice** to reveal the name of the program controlling the PRE-SET buttons. If you are using the MP settings, this will read VITA-MIX SMOOTHIE PROGRAM.
- **Press a third time** to reveal an option to reset the PRE-SET buttons to the original factory settings.
- **Press a fourth time** to exit and continue blending.

HIGH/LOW PULSE Button - The PULSE provides a quick increase or decrease in speed of the blade when blending or refreshing a drink. Press H to increase the motor to speeds that range from 51%-100%. Press L to decrease the motor speed down to a range of 50% -7%. The PULSE button will override the running program as long as it is depressed. Once released, the original program continues its cycle.

- The PULSE High (H) and Low (L) speed is set by using the SPEED CONTROL buttons. To set, while pressing and holding a PULSE button, press the SPEED CONTROL ▲ or ▼ button until the desired motor speed is reached. The PULSE speed will remain at this setting until changed again with the SPEED CONTROL buttons.

Custom Programming

The Blending Station® MP is packaged with a smoothie programming chip. Please keep the chip in a safe, easily accessible spot and always keep it in the original package. This chip is used to program your machine with the six smoothie programs optimized for the XP container. Although your machine comes from the factory pre-set, follow these instructions when using the supplied programming chip, in the event your machines PRE-SET buttons were altered.

Programming your On-Counter Blending Station MP PRE-SET Buttons

1. Turn the machine on.
2. Remove the container and lift the front of the machine so that you can see the programming port.
3. Facing the front of the machine, insert the custom programmed chip (with the silver contact bars up and the words, "THIS SIDE FACING TO THE FRONT OF THE MACHINE" toward you) into the port located below the label area. Push gently until the chip engages into the port. The display window will read "NEW MODULE."
4. Within 10 seconds, the six PRE-SET buttons will be re-programmed and the display window will read "SAVED" then "READY." If the above programming steps are taken and the custom programming does not appear with the first blend cycle, turn the chip 180° (side-to-side) and try again.
5. Remove the programming chip, return it to the original package and store in a safe, easily accessible spot.
6. Press one of the six PRE-SET buttons to reveal, in the display window, the name of the program/drink.

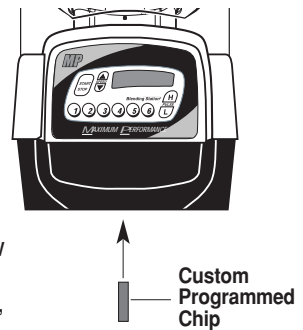

Programming your In-Counter Blending Station MP PRE-SET Buttons

1. Turn the machine on.
2. Remove the container and lift the machine from the bottom edges to reveal the motor and housing area. With the machine facing towards you, locate the slot underneath on the right hand side of the machine between the motor and the outer wall.

3. Facing the front of the machine, insert the custom programmed chip (with the silver contact bars up and the words, "THIS SIDE FACING TO THE FRONT OF THE MACHINE" toward you) into the port located below the label area. Push gently until the chip engages into the port. The display window will read "NEW MODULE."
4. Within 10 seconds, the six PRE-SET buttons will be re-programmed and the display window will read "SAVED" then "READY."
5. Remove the programming chip, return it to the original package and store in a safe, easily accessible spot.
6. Press one of the six PRE-SET buttons to reveal, in the display window, the name of the program/drink.
7. Carefully place the Blending Station MP motor back into the hole in the counter.



Resetting the PRE-SET Buttons to the Original Factory Settings



CAUTION: Please read all steps before reprogramming. Resetting the PRE-SET PROGRAM buttons will revert the six program buttons to times that are not optimized for the XP container. Use the program chip supplied with your machine and follow the instructions on page 6 for programming your machine with the correct XP programs.

1. Press the OWNER CONTROLS button (Vita-Mix logo). "MODE" will appear in the display window. Press the PRE-SET buttons 1 and then 6. The display window will say "COUNT TEMP TOTAL."
2. Press the Vita-Mix logo two more times to reveal the instructions on resetting the PRE-SET buttons.
3. Press and hold button 4 until the display window reads "RESTORING PLEASE WAIT." The PRE-SET buttons are now reset to the original factory settings.

Lid and Cover Assembly

NOTE: Outside the United States and Canada, your Blending Station® MP may come with a different container configuration.

Two-Piece Lid

48 oz. / 1.4 Ltr. Xtreme Performance (XP) Container

The two-piece lid is easy to clean and easy to put on, take off and seal.

- To remove a fully latched lid, lift the two tabs and pull upward and off.
- Twist the center lid plug to fasten or remove.

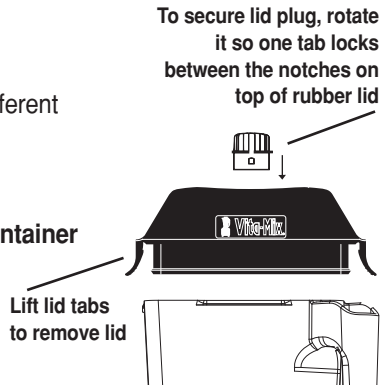

Figure A

NOTE: Blending Station MP machines are optimized for use with the Vita-Mix 48 oz. / 1.4 Ltr. **Xtreme Performance (XP)** container. Use of Vita-Mix Standard containers (48 oz. / 1.4 Ltr. or compact 32 oz. / 0.9 Ltr.) may require programming adjustments. The 48 oz. / 1.4 Ltr. Xtreme Performance (XP) container **may not** work with earlier Vita-Mix models. The 64 oz. / 2.0 Ltr. standard container will not fit in the compact cover used on the Blending Station MP. Call Vita-Mix Customer Service or your distributor for more information.

One-Piece Lid (optional)

48 oz. / 1.4 Ltr. Xtreme Performance (XP) Container

The one-piece lid is easy to clean and easy to put on, take off and seal.

- There is no lid plug for this lid.
- Add ingredients through port on top.

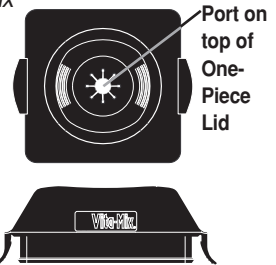

Figure B – Top and Side view

Compact Cover

Cover Door:

1. The Cover Door can be removed by opening it until the door is horizontal. Then, gently spread the sides of the door over the round hinges and remove.
2. To reinstall the Cover Door, gently spread the sides of the door and place the door hinge cutouts over the round hinges.

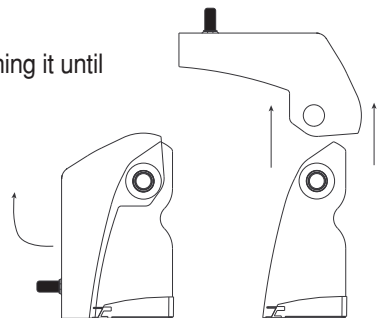

Figure C

Back Cover:

1. To remove the Back Cover from the Blending Station:

- a. First remove the Cover Door from the unit as described above.
- b. Remove the two (2) Back Cover mounting screws from the rear of the machine (see Figure D).
- c. From the rear of the machine, firmly push the bottom of the cover forward (towards the Control Panel), keeping the bottom edge of the cover against the Motor Base. **DO NOT tilt or strike the cover during removal.**
- d. Slide forward until the side latches on the front of the cover are released from the Motor Base (see Figure E). **DO NOT strike the cover to “pop” the side latches from their tracks. Doing so will cause damage. The cover must only be removed by sliding it forward (towards the Control Panel).**

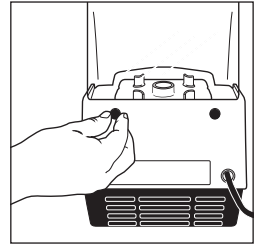

Figure D

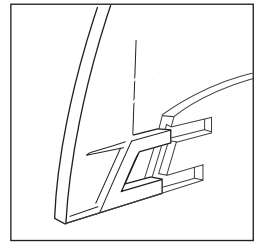

Figure E

2. To replace the Back Cover on the Blending Station:

- a. Place the Back Cover on the Motor Base approximately one 1 inch / 2.4 cm forward of its normal position.
- b. Slide the cover towards the back of the machine (away from the Control Panel). **Make sure the side latches slide into their tracks.**
- c. Push until back of cover is seated against the Motor Base (see Figure F). **Make sure the Back Cover is fully seated in the back and the side latches are in their grooves before inserting and tightening the mounting screws.**

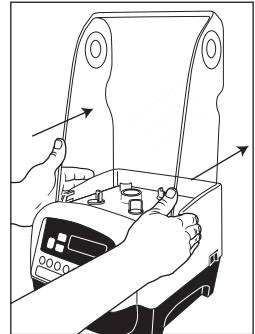

Figure F



- d. Replace and firmly hand-tighten the two (2) Back Cover mounting screws (see Figure D). **DO NOT over-tighten or use any tools to tighten. DO NOT use the mounting screws to pull the Back Cover into position. Doing so will cause damage.**

Installation

In-Counter Blending Station MP

Preparing the Counter Area:

- Before cutting holes, make sure that there is adequate clearance under the counter for the motor. The motor will extend about 5.67 in. / 14.4 cm below the counter but it is best to allow at least 10 in. / 25.4 cm from the under-counter to shelves or any other equipment under the counter. Also, when using the removable cover design, the back of the hole must be at least 4.25 in. / 10.8 cm from any wall to allow for cover door clearance.
- An extra 4 in. / 10.16 cm of open space above the top of the cover will be needed for placement and removal of the In-Counter machine and for custom programming the six PRE-SET buttons.
- If installing unit into a closed cabinet, including cabinets with a curtain or extended skirt, a 4 in. / 10.16 cm diameter flexible vinyl duct (dryer hose) must be used to vent exhaust. Attach the vinyl duct to the bottom exhaust by forcing the end of the hose over the exhaust baffle of the unit. **Run the vinyl duct out of the cabinet for proper ventilation. Do not vent hose into a wall, ceiling or a concealed space of a building or cabinet.** Multiple units should not vent to a common manifold unit but to separate places with separate vent ducts.



DO NOT use hose clamps or equivalent to attach exhaust hose on machine.

- When cutting holes for placement of multiple In-Counter units, position the edge of the machines at least 12 in. / 30.48 cm apart to ensure quick cleaning and proper venting between machines.
- It is recommended that for a 120 VAC unit In-Counter installation, you have at least one 20 amp outlet per machine under the counter, available within 6 ft. / 1.8 m of the Blending Station MP. 220 VAC and 100 VAC units require a dedicated line. **Consult an electrician for proper electrical needs.**
- The In-Counter Blending Station also requires a gasket (provided in the machine's original package) to be placed between the machine and the counter. See page 12 for instructions.
- Refer to the Vita-Mix Blending Station In-Counter Template (provided in the machine's original package) for detailed installation guidelines and a template.

NOTE: The area below the counter must have adequate ventilation to provide air circulation around each motor. This will prolong the life of your Blending Station. If storing powders, mixes, sugars, etc., make sure containers are tightly

sealed. The intake and exhaust air caused by the Blending Station will disperse any loose products within the cabinet and unit.



DO NOT strike the blender when removing from the counter.

On-Counter and In-Counter Blending Station MP

Electrical Requirements:

- 120 VAC • 50/60 Hz • 15 Amps

The 120 VAC Blending Station MP is built using a U.S. three-prong grounded cord. 20 amp outlet per machine is recommended.

- 220/240 VAC • 50/60 Hz • 1300-1550 Watts
- 100 VAC (Japan) • 50/60 Hz • 1000 Watts

Dimensions:

On-Counter

- 19.5 in. / 49.5 cm high with lid closed
- 26.75 in. / 67.94 cm high with lid open
- Depth: 10.5 in. / 26.67 cm with handle
- Width: 9.5 in. / 24.13 cm

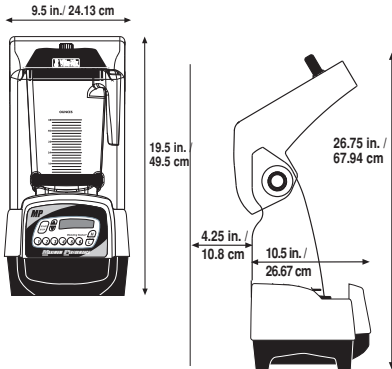

In-Counter

- 15 in. / 38.1 cm high with lid closed
- 22.25 in. / 56.52 cm high with lid open
- Depth: 12.5 in. / 31.75 cm with handle
- Width: 9 in. / 22.86 cm
- Depth below counter: 5.67 in. / 14.4 cm

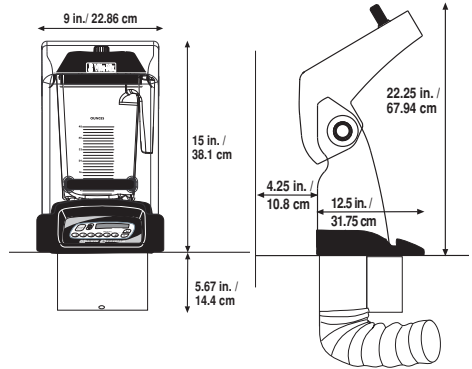

Recommended distance between machines and underhang or wall: 12 in. / 30.48 cm from the edge of each machine or as far apart as possible.

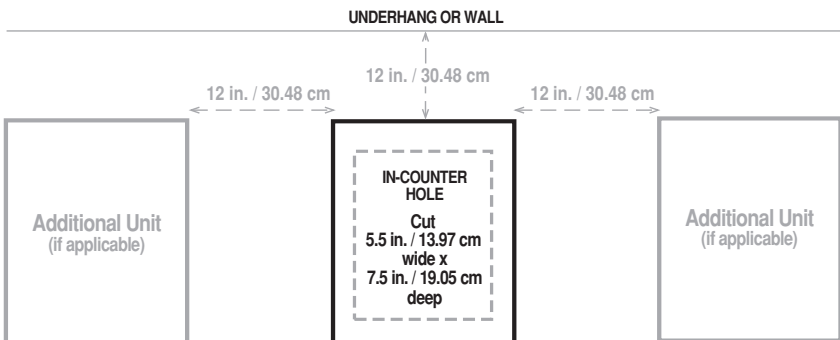

In-Counter Gasket

Gasket Installation Instructions:

1. Follow the instructions on page 10 for preparing the counter area for the installation of your In-Counter Blending Station.[®] Also, use the Template Sheet (provided in your machine's original package) to assist you in the placement and ventilation of your machine.
2. Unplug the machine. Lay the machine on its back with the motor pointing toward you. Allow 1-2 in. / 3-5 cm of the motor base to hang over the edge of the counter top to facilitate easy fitting of the gasket.
3. Slide the power cord through the gasket, with the groove of the gasket pointing toward the machine base.
4. Starting at one corner of the motor base, press the gasket onto the motor base so that the groove in the gasket seats itself onto the stepped bottom edge of the motor base (see Figure B).
5. Working around the bottom edge of the motor base, press the gasket onto the motor base until the entire perimeter of the gasket is firmly attached to the motor base.
6. Carefully place the machine into the hole in the counter.
7. Be sure that the gasket is properly seated on the motor base and against the counter top.

NOTE: DO NOT secure the machine to the counter with bonding materials.



This gasket was designed to protect your machine from water damage and to reduce noise. Failure to properly install this gasket could result in moisture damage.

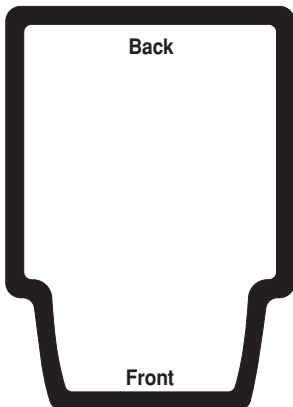

Figure A

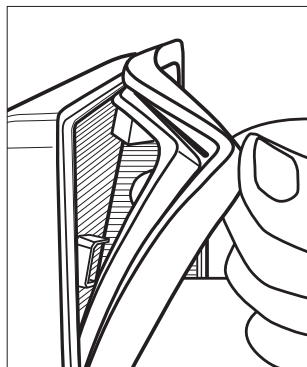

Figure B

Blending Tips

1. If your recipe freezes up, try reducing the amount of ice. Compared to other blenders, you do not need as much ice to make an equally frozen drink in a Blending Station® MP.
2. Place liquids and soft foods in your container first. Hard items and ice should be placed last.
3. Whole, hard or frozen ingredients should be small. Solid frozen fruit is extremely difficult to blend. For best results, use semi-frozen fruit. Using same size batches of semi-frozen fruit and ice will keep your drinks consistent. If you notice chunks, reevaluate the batch size.
4. When creating recipes, always allow for enough liquid to ease the blending process. For recipes with minimal liquid, use the SPEED CONTROL buttons to run the machine on its lowest settings until it is processing smoothly. Finish blending by using one of the Pre-Set Programs that best matches the drink's viscosity.

Maintenance Tips:

- **NEVER bang the container against a surface to loosen the ingredients.**
Remove the container from the base and use a rubber spatula to remove thick mixtures from the bottom of your container.
- **NEVER shake or rattle a container while in use.**
- **NEVER remove the container before the machine has come to a complete stop.**
- **NEVER start the motor before the container is in place.**



Important: Check your blades daily for loose, nicked or missing parts. If you find something is loose, nicked or missing, replace the blade assembly before use. Do not tighten hex-headed screw (on top of blade assembly). If loose, replace blade assembly.

The instructions appearing in this Owner's Manual cannot cover every possible condition and situation that may occur. Common sense and caution must be practiced when operating and maintaining any appliance.

nstructions

Blending Station® MP Instructions Using the Six PRE-SET Program Buttons

The following is the basic XP setting of the six PRE-SET buttons for the Blending Station MP machines. These programs, numbered 1 through 6, are blending cycles designed for the most commonly made drinks. Depending on the viscosity of the drink you are creating, selecting one of the PRE-SET programs will run the machine for a full cycle. The machine will stop by itself when the cycle is complete. A cycle varies in speed and length. Your machine's PRE-SET options may differ due to program revisions or if your machine was programmed specifically for your business. Due to the difference of recipes, your results may also vary.

- **Button 1:** (:13) *Blends thin drinks with just juice and ice.* Button 1 will ramp the blending speed to high (87%) for 13 seconds.
 - **Button 2:** (:18) *Blends light coffee drinks.* Button 2 will ramp the blending speed to high for 18 seconds.
 - **Button 3:** (:20) *Creates a specialty drink with a thick viscosity.* Button 3 will ramp the blending speed to high for 20 seconds.
 - **Button 4:** (:15) *This cycle is good for ice cream and regular coffee drinks.* Button 4 increases to medium speed for 5 seconds and then ramps up slowly to high for 10 seconds.
 - **Button 5:** (:20) *Blend a regular smoothie on high.* Button 5 increases to medium speed for 10 seconds and then ramps up slowly to high for 10 seconds.
 - **Button 6:** (:25) *Blend thick frozen fruits & hard ingredients for a thick but consistent smoothie.* Button 6 increases to medium speed for 10 seconds and then ramps up slowly to high for 15 seconds.
1. Place liquids and soft foods in the container first, solid items and ice last. Although not necessary for processing, you may want to cut or break food into smaller pieces for more precise measuring of ingredients. Thawed or partially thawed fruit is recommended. Button 5 or 6 is recommended for heavy-duty blending.
 2. Set the container on the motor base by aligning it over the centering pad anchored to the base. (**Motor must be completely stopped before positioning container.**) Containers are not to be used for hard, dry materials. Avoid running your machine with the container empty.
 3. Always use a lid when blending.

4. Plug the machine into the nearest outlet (if unplugged). Press the ON/OFF switch to ON. Select desired programmed setting by pressing any of the PRE-SET buttons 1 through 6. The machine will immediately begin to cycle through the selected program and turn off when the program is complete. Each button has a different pre-selected combination of speed and length for blending.
5. Once one of the six PRE-SET program buttons is pushed, the machine will start and stop automatically. By pressing another PRE-SET button or the START/STOP button, the machine will stop the blending cycle.

WARNING: If you detect a change in the sound of the machine or if a hard or foreign object comes into contact with the blades, do not serve the drink. Inspect your blade assembly for loose, nicked or missing parts. If parts are loose, missing or nicked, replace with a new blade assembly. (See page 17.)

6. During any of the blending cycles, by pressing the PULSE H button, the speed of the blending can increase up to 100% of the motor speed. By pressing the PULSE L button during a blending cycle, the speed of the motor can be decreased down to 7%. Once released, the motor speed will revert back to the blending cycle of the PRE-SET program.

NOTE: Use the SPEED CONTROL buttons to set the speed of the PULSE buttons. For example, when the H or L PULSE button is pressed and held, by simultaneously pressing and holding the ▲ or ▼ SPEED CONTROL button, the motor speed will increase or decrease in 1% increments. When the SPEED CONTROL button is released, the PULSE button will remain set at the selected speed until altered with the SPEED CONTROL buttons.

7. When the cycle is complete, the blender stops. **Wait until blade comes to a complete stop before removing the lid and/or container from the motor base.**
8. Remove the container, pour, garnish and serve the drink.
9. Press the ON/OFF switch to OFF when not in use.

Blending Station® MP Instructions Using the START/STOP and SPEED CONTROL Buttons

Although using the PRE-SET PROGRAM buttons is highly recommended for the best drink, occasionally a drink may need special attention. By using the START/STOP button and the SPEED CONTROL button, you can manually control the speed of the Blending Station MP.

CONTINUED ON PAGE 16

Instructions

CONTINUED FROM PAGE 15

1. Follow steps 1 through 3 of “Blending Station® MP Instructions Using the Six Pre-Set Program Buttons” section on page 14.
2. The speed of the motor can be changed with:
 - the motor off:
 - Press the ▲ or ▼ buttons until the desired speed percentage is displayed. 100% is the highest setting and 7% is the lowest setting.
 - When the START/STOP button is pressed, the motor will ramp quickly to that speed.
 - Blending can be stopped by pressing the START/STOP button at any time.
 - the motor on:
 - With the container in place, press the START/STOP button. The machine will begin blending.
 - While the machine is running, press the ▲ or ▼ buttons until the desired speed percentage is displayed. 100% is the highest setting and 7% is the lowest setting.
 - Release the SPEED CONTROL button and the motor will now run at the desired speed.
 - The blending can be stopped by pressing the START/STOP button.
3. The PULSE button can also be used to quickly increase the motor speed or decrease the motor speed. (See HIGH/LOW PULSE button description on page 5.)
4. When finished blending, press the START/STOP button to stop the motor.
Wait until blade comes to a complete stop before removing the lid and/or container from the motor base.
5. Remove the container, pour, garnish and serve the drink.

NOTE: On all units, the built-in thermal protector keeps track of how hot the motor gets and will warn the user and eventually shut down the motor if the motor is overheating. When overheated, the display will instruct the user to remove the container and run the machine until cool. This takes about two minutes. See page 25, “Cooling the Motor,” for complete instructions. When the thermal protector shuts the motor off, review your processing techniques and your instructions. Your recipes may be too thick or have too much material in them. Consider adding more liquid and consult Vita-Mix® or your local Vita-Mix Distributor for further assistance.

Blade Assembly

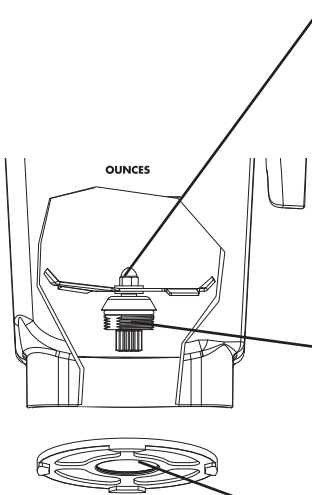

Blade Agitator Assembly. The blade assembly includes a precision-hardened stainless steel blade with enclosed steel ball bearings for maximum durability. The rugged blade assembly literally explodes molecules of food and ice in the container, helping every batch to homogenize more effectively. The blade does not need to be removed for normal cleaning. (Refer to the information below to remove or replace.)

Drive Spline. Mates with drive socket on the motor base to turn the blade. **NOTE:** Removing and replacing your container while the coupling is still rotating will strip the drive spline “teeth.” (This part is NOT removable.)

Retainer Nut. Must be snug. Order the available Retainer Nut Wrench for best results. (Refer to the information below to remove or replace.)



Never use a blade assembly with loose, damaged or nicked components.
CAUTION: Do not remove blades unless absolutely necessary! Never attempt to take the blade assembly itself apart. This will void the warranty.

Blade Assembly Removal

At times, it may be necessary to give your blades additional cleaning. An easy-to-use blade assembly removal wrench (Item #15596) may be purchased through your Vita-Mix Distributor. Turn the container upside down and grip firmly. Insert retainer nut wrench in groove of retainer nut and rotate counterclockwise to loosen. Then grip blades with a cloth and remove retainer nut by hand.

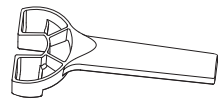

Retainer Nut Wrench

Replacing Blade Assembly. With the container upside down, grip blades with cloth, insert into the container bottom and align with flat sides of container opening. Place retainer nut on and hand tighten. Last, carefully turn clockwise until secure, using wrench. **DO NOT FORCE.** If it is not tight enough, you will notice increased container noise.

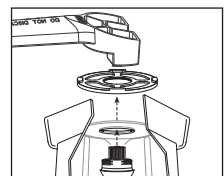

Retainer Nut Wrench in use.

Parts List

Blending Station® MP

Item#	Part
#1159	Lid Plug for 48 oz. / 1.4 Ltr. XP Container
#15575	Lid only (no plug) for 48 oz. / 1.4 Ltr. XP Container
#15574	Two-part lid assembly for 48 oz. / 1.4 Ltr. XP Container
#15566	48 oz. / 1.4 Ltr. XP Container, blade assembly & lid assembly
#15569	48 oz. / 1.4 Ltr. XP Container only
#15567	48 oz. / 1.4 Ltr. XP Container, blade assembly, no lid assembly
#15598	XP blade agitator assembly
#15585	XP retainer nut
#891	Drive socket
#15579	Sound-reducing XP centering pad
#18006	Compact back cover and cover door with removable hinge design
#18007	Compact cover door
#18008	Compact back cover
#18005	Metal screws with plastic caps - 2
#15603	In-Counter gasket

NOTE: Other than the drive socket, blade assembly and retainer nut, this unit is not user serviceable.

Outside the United States and Canada, your machine may come with a different container configuration. Contact your local Vita-Mix Distributor for item numbers.

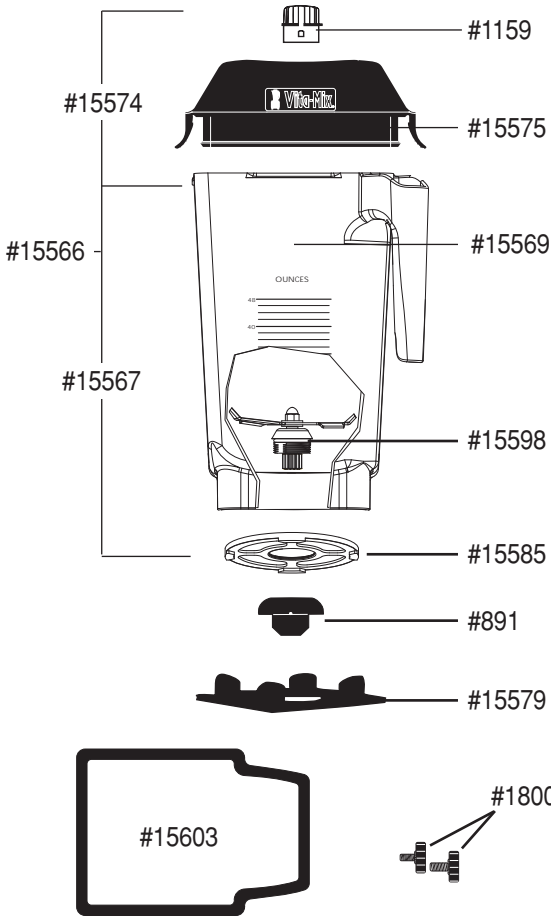

Items Sold Separately:

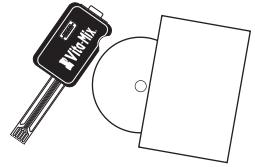

#15606 Software Kit – USB Version

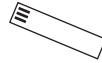

#15644 Extra Programming Chip for Software Kit



#15576 One-Piece Lid

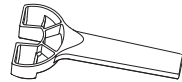

#15596 Retainer Nut Wrench

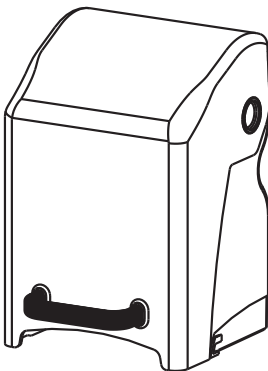

#18006

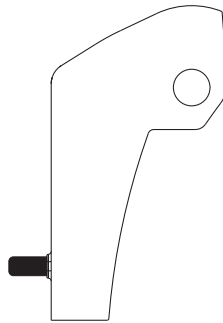

#18007

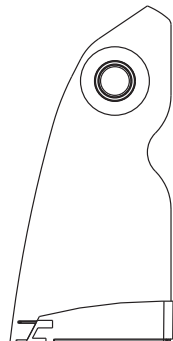

#18008

Care and Cleaning

Care Note

To ensure that you get the longest possible life from your Vita-Mix machine, we recommend the following products, when used as directed by the supplier:

Cleaning Products

Suppliers in USA

Solid Supra, Solid Power, **Ecolab, Inc.**, St. Paul, MN
Guardian Acclaim, Solid Guardian Plus, 800-352-5326
Solid Super Impact, Solid Insure www.ecolab.com
Diverpak **Diversey**, Livonia, MI
Eclipse H2 800-521-8140
Liqui-Safe L7

Klenzade Products

Acclean Division of Ecolab
Poly-Brite St. Paul, MN
612-293-2165

Wesmar Company, Inc.

Glow MB-1 Seattle, WA
Lustre NC-25 206-783-5344
Lustre Plus www.wesmar.com

Anderson Chemical Co.

PSRA 41-D, PSRA 41-E Litchfield, MN
Liqui-Ware 1, Liqui-Ware MC 800-366-2477
D-Flex, Sur-Met www.andersonchemical.com

Rinse Aids

Suppliers in USA

Solid Rinse Dry **Ecolab, Inc.**, St. Paul, MN
Solid Brilliance 800-352-5326
Jet Dry, Rinse Dry www.ecolab.com

Destainers

Suppliers in USA

NuWare **Diversey**, Livonia, MI
800-521-8140

 **DO NOT use abrasive cleaning agents or concentrated bleach when cleaning. DO NOT use any cleaners containing Quaternary Sanitizers on polycarbonate components (i.e., containers, covers). DO NOT use any of the following cleaning products: automatic dishwashing detergents, oven cleaners, steel wool or other abrasive pads.**

Container: Do not let mixtures, liquids and food products dry in the container. Rinse throughout use. Dry product may lock around the blade and weaken/tear the bearings seal when restarted. Do not place containers in the freezer. Extremely low temperature combined with hot ingredients and/or the immediate rapid action of the blade may crack the container. Due to the nature of polycarbonates, microwaving and automatic dishwashing are not recommended. Follow the cleaning instructions on page 22.

Motor Base/Control Panel

1. **Unplug the power cord.**
2. Gently wash the outside surface with a damp soft cotton cloth moistened with a mild solution of warm water and nonabrasive detergent or nonabrasive liquid spray cleaner. Be careful to not scratch or scrub the display window on the control panel. **NEVER IMMERSE MOTOR BASE IN WATER OR OTHER LIQUID.** Dry with a soft cotton cloth.

NOTE: Be sure to wring excess water out of cloth or sponge when cleaning around the controls or any electrical part.

Lid

Separate the lid and plug. Wash in warm, soapy water. Rinse clean under running water and dry. Reassemble before use. (See page 8.)

Cover Door

The cover can be removed (see page 9) and cleaned by placing under running water and washing with a soft cloth. Wipe dry and replace back on the base.

NOTE: Do not wash cover door, handle or back cover in dishwasher. It is recommended that the handle not be disassembled during cleaning. However, if you choose to disassemble the handle from the cover, make sure to not overtighten it when reattaching it to the cover. Doing so will cause damage.

In-Counter Gasket and Container Centering Pad

Wash the gasket and pad in warm, soapy water. Rinse clean under running water and dry. Reassemble before use. (See page 12.) **Make sure the gasket is seated properly against the blender and the counter and the centering pad is flat on the motor base.**

Care and Cleaning

CONTINUED FROM PAGE 21

Container

For maximum container life, do not wash in dishwasher.

Before cleaning, ensure that lid plug is rotated clockwise.

1. To Clean: Fill container 1/4 full with warm (110°F/43°C) water and add a couple drops of liquid dishwashing detergent.* Return container to motor base and firmly position the two-piece lid. Run machine for 30 seconds. Empty container. Repeat this step.

***NOTE: To prolong polycarbonate container life, Vita-Mix recommends using soaps with a low Ph balance, such as a liquid dishwashing detergent (Ivory Liquid®). Due to the nature of polycarbonates, automatic dishwashing is not recommended.**

2. To Rinse: Fill container 3/4 full with warm (110°F/43°C) water – do not add soap. Return container to motor base and firmly position the two-piece lid. Run machine for 30 seconds. Empty container.
3. If any solid residue remains, remove the blade agitator assembly (see page 17) and wash all container parts in warm soapy water. Rinse and drain. Reassemble before next step.



DO NOT soak the blade agitator assembly.

4. To Sanitize: If all solid residue is gone after step 2 or after completion of step 3, fill container 3/4 full with a sanitizing solution mix.** Return container to motor base and firmly position the two-piece lid. Run machine on a high speed for 30 seconds. Turn machine off and allow mixture to stand in the container for an additional 1-1/2 minutes. Pour out bleach mixture.
5. Return container to motor base and run machine empty for an additional 5 seconds. Do not rinse after sanitizing. Allow container to air dry.

**Recommended sanitizing solution: 1.5 tsp. / 7.4 ml institutional or household bleach in 2 qt. / 2.0 Ltr. water.

Specifications

Dimensions:

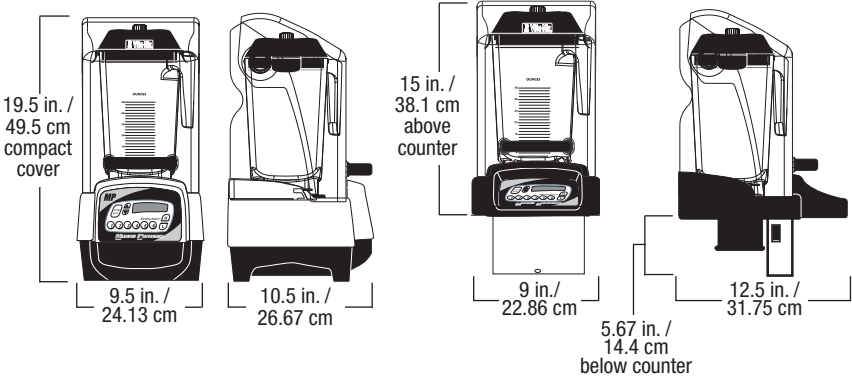

Blending Station® MP On-Counter:

Overall dimensions: 19.5 in. / 49.5 cm High x 9.5 in. / 24.13 cm Wide x 10.5 in. / 26.67 cm Deep

Shipping weight: 19.5 lbs. / 8.9 kg

Blending Station MP In-Counter:

Overall dimensions: 15 in. / 38.1 cm above counter
5.67 in. / 14.4 cm below counter x
9 in. / 22.86 cm Wide x 12.5 in. / 31.75 cm Deep

Shipping Weight: 17.5 lbs. / 7.9 kg

Power Requirements:

Volts: 120 VAC

Amps: 15

Hz: 50/60

Volts: 220-240 VAC

Watts: 1300-1550

Hz: 50/60

Volts: 120 VAC EMC Taiwan

Amps: 15

Hz: 50/60

Volts: 100 VAC (Japan)

Watts: 1000

Hz: 50/60

When applicable:



Please recycle this item in accordance with local laws and regulations.

Troubleshooting

1. Problem:

- Loud noise from blender container blade area
- Container blades do not spin
- Increased vibration
- Leaking from bottom of container

Solution #1:

Broken or worn drive socket. Replace (Item #891). Instructions are included with part.

Solution #2:

Check blade assembly for loose, damaged or nicked components and replace.

Solution #3:

Tighten retainer nut with the retainer nut wrench moving clockwise until it is snug. (See page 17.)

2. Problem:

- Loud grinding noise from the blender motor

Solution #1:

Due to some damaged motor bearings, your machine may need to be repaired. Call Vita-Mix Technical Support.

3. Problem:

- Machine will not run
- Display window does not say "READY"

Solution #1:

Double-check to make sure power cord is firmly in power outlet.

Solution #2:

Check to make sure the ON/OFF power switch is in the ON position.

Solution #3:

Turn the ON/OFF power switch to OFF, then ON, to reboot the electronics.

4. Problem:

- Machine starts then shuts off

Solution #1:

Check to make sure there is power to the machine.

Solution #2:

Call Vita-Mix Technical Support.

5. Problem:

- Display window reads



SHUTDOWN
SEE MANUAL

Solution #1:

Let the machine cool down for an hour, then restart.

Solution #2:

Call Vita-Mix Technical Support.

6. Problem:

- Display window reads



MOTOR LOCKED PROGRAM
TERMINATED

Solution #1:

Let the machine cool down for an hour, then restart.

Solution #2:

Call Vita-Mix Technical Support if the machine does not work after sitting at room temperature for 24 hours.

7. Problem:

- Machine is running irregularly
- “NO PROGRAM” is displayed when a button is pushed
- Button pressed starts wrong program
- Machine starts by itself
- A specific program button is defective
- Machine was turned off for a day, week or month and turned on, but there is no power
- Machine does not work when first tried
- Machine works but no information displayed on screen
- Program buttons run the blender on the same speed

Solution #1:

Reset the machine to its original factory settings. (See page 7.)

Solution #2

Try plugging the machine into a new outlet.

Solution #3:

Call Vita-Mix Technical Support.

8. Problem:

- Display widow reads



CORRUPT DATA

Solution #1:

Reset the machine to its original factory settings. Reinstall the original programming chip (if included).

Solution #2:

Call Vita-Mix Technical Support.

9. Problem:

- Display window reads “THERMAL SENSOR FAILURE”

Solution #1:

Call Vita-Mix Technical Support.

10. Problem:

- Machine stops in the middle of its blend cycle and resets; display window reads “VITA-MIX GENERAL PROGRAM” then “READY”

Solution #1:

Plug the machine into its own power supply.

Solution #2:

Make sure the machine is not running on a long extension cord.

Cooling the Motor:

If the machine has overheated:



MOTOR HAS OVERHEATED REMOVE...
HOT SHUTDOWN

- The motor will stop and the message “MOTOR HAS OVERHEATED REMOVE THE CONTAINER, THEN PRESS START,” will scroll across the display window, while the words “HOT SHUTDOWN” will remain in the display window alerting you of the problem.
- The machine will not run until the container is removed and the motor has cooled. Remove the container, shut the cover door and press the START/STOP button and run the machine for two minutes.
- When the motor is cool, “READY” will appear in the display window.



READY

If you cannot fix your machine with these suggestions, technical help is available by calling Vita-Mix Technical Support at **800-886-5235**. If outside the United States and Canada, contact your local Vita-Mix Distributor or telephone the Vita-Mix International Division at +1.440.782.2450 or email international@vitamix.com for a distributor in your country. For online help, visit www.vitamix.com/foodservice.

Warranty

Limited Warranty

Vita-Mix® Corporation warrants your Commercial Vita-Mix machine to be free from defects in materials and workmanship for a period of three years from the date of purchase when used in accordance with the accompanying instruction booklet.

Provisions of this limited warranty are void if your Vita-Mix machine has been subjected to obvious abuse, negligence, accident, alteration, or failure to follow operating instructions, or product exposure to abnormal or extreme conditions. Cosmetic changes such as discoloration of parts of the product in the hands of the user or the effects of the use of abrasive cleaners will not be warranted or considered defects. The cleaning or removal of food products along with any damage caused by allowing them to build up is not covered by this limited warranty. Improper installation of the In-Counter Blending Station® model is not covered by this warranty. Warranty is void if the Vita-Mix machine is put into a sound reduction chamber or prevented from receiving proper cooling.

In the event your Vita-Mix machine needs service or repair covered by the terms of this warranty, please call the Vita-Mix Corporation for shipping instructions. The Vita-Mix machine must be sent in original or sufficient packaging.

This limited warranty is in lieu of any other warranty expressed or implied.

No representative or any other person is authorized to make any other warranty or to assume any liability not strictly in accordance with the foregoing. This limited warranty gives you specific legal rights which may vary from state to state.

Proof of purchase may be required to prove date of purchase.

Outside the United States and Canada, other warranties may apply. Call or check with your local Vita-Mix Distributor for details or telephone the Vita-Mix International Division at +1.440.782.2450 or email international@vitamix.com.

In case of shipping damage, notify the shipper or carrier immediately. Outside the United States or Canada, contact your local Vita-Mix Distributor.

Service Contract

Please Note: The Service Contract outlined in the following paragraphs applies only to customers in the United States and Canada. Customers in all other countries should contact their local Vita-Mix® Distributor for service details.

This Vita-Mix machine includes a 1-Year Service Contract effective from date of purchase. In the event your machine should need parts or repairs covered under this Service Contract, call Vita-Mix Customer Service immediately for instructions. Proof of date of purchase may be required. This does not cover abuse, misuse, tampering, improper installation or extreme conditions.

The Vita-Mix Service Contract includes the following:

1. One extra drive socket – to facilitate simple repairs and prevent down time – is included and packaged with each machine.
2. Additional drivers, unless defective, are not covered. **NOTE:** to determine if you have a defective part, please order a replacement part through Vita-Mix Customer Service and, when the new part arrives, return the old part in the same packaging. Vita-Mix will inspect the returned part and, if defective, issue a refund for the price of the new part. A part will be considered defective if no abuse or neglect was involved with its break. Non-defective parts sent to Vita-Mix for inspection will not be returned if deemed unusable. Service Contract covers functionality of the machine but not abuse or lack of recommended maintenance.
3. In the Continental United States, sender pays freight one way to Vita-Mix Corporation. The Vita-Mix Corporation pays UPS ground freight charges to return the machine to the sender. Sender pays costs for special shipping requests.
Outside the Continental United States, other service contracts may apply.

Before returning this product for any reason, including repair, please first contact our **Technical Support Department**. In the US and Canada, call **800-886-5235** to receive a “Return Authorization” Number. **Any return without a “Return Authorization” Number will not be processed and will be returned to sender.** Outside the United States, contact your local Vita-Mix Distributor.

NOTE: Within the United States, Limited Warranty and Service Contract are honored directly through the Vita-Mix Corporation, Cleveland, Ohio USA. Non-warranty repairs can be performed by any CFESA service center. For machines sold in the United States, call Vita-Mix Technical Support: 800-886-5235. If you live outside the United States or Canada, contact your local Vita-Mix Distributor, or telephone the Vita-Mix International Division at +1.440.782.2450 or email international@vitamix.com for a distributor in your country.

Additional Vita-Mix® Accessories Available!



To rinse containers quickly between servings, the **Vita-Mix Rinse-o-matic®** is ideal. Rinses clean in seconds!
Item #1410



To scrub tough ingredients, use the new **Vita-Mix Container Brush**. Soft, flexible fibers scrub in seconds but won't scratch!
Item #15639

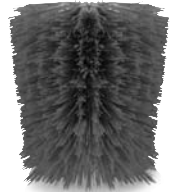

For more information on these accessories, call 800-4DRINK4 (800-437-4654) or 440-235-0214. If you live outside the United States or Canada, contact your local Vita-Mix Distributor or telephone the Vita-Mix International Division at +1.440.782.2450 or email international@vitamix.com for a distributor in your country.

To see the complete line of Vita-Mix products, visit www.vitamix.com/foodservice



VITA-MIX® CORPORATION
Foodservice Division
8615 Usher Road, Cleveland, Ohio 44138-2103 USA

©2007 Vita-Mix Corporation. No part of this publication may be reproduced or transmitted in any form or by any means or stored in a database or retrieval system without the written permission of the Vita-Mix Corporation.