

# In-Counter Blending Station® Advance

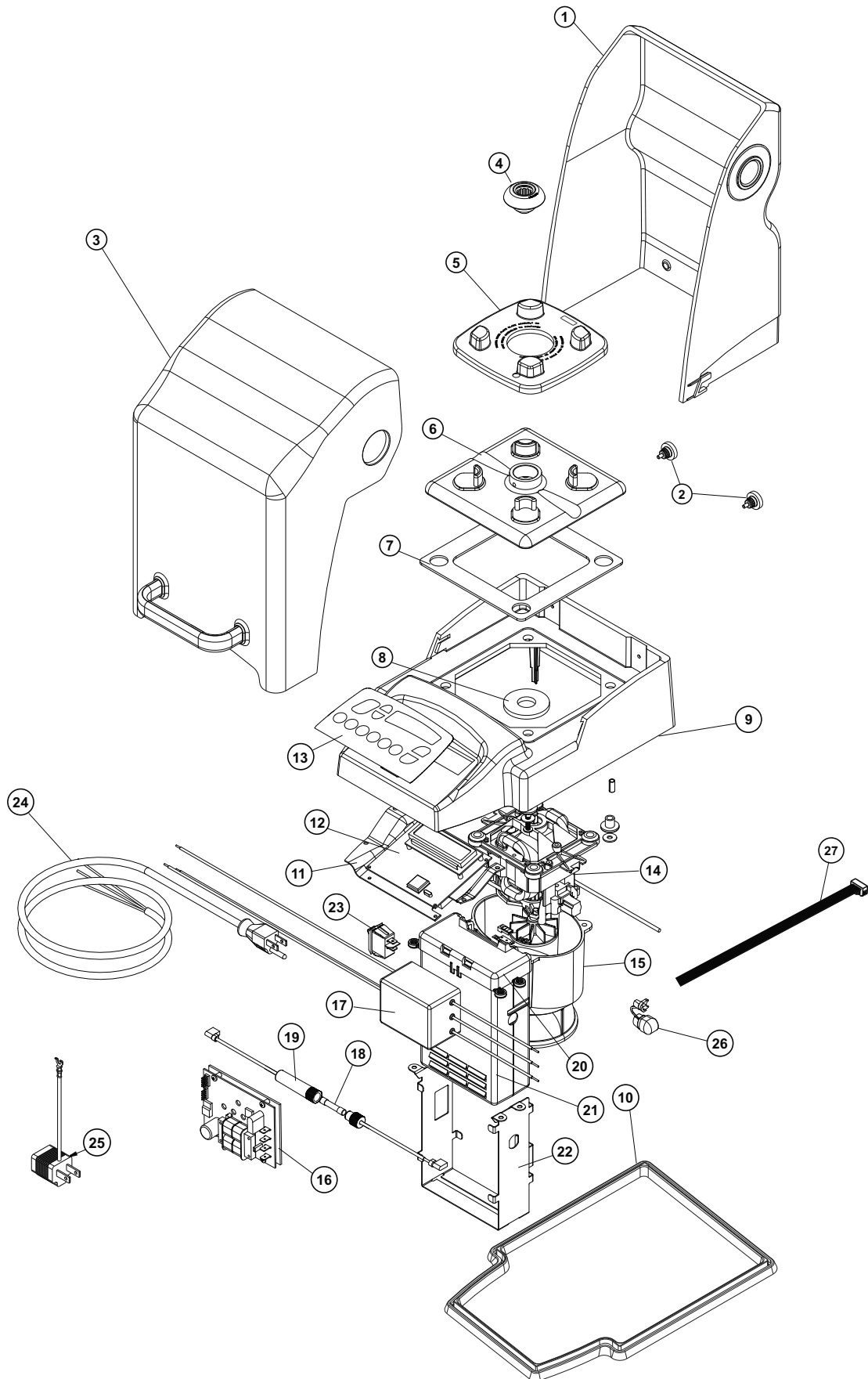

# ***In-Counter Blending Station® Advance Parts List – 100V (Japan), 120V, 120V (Taiwan), 220/240V***

<b>NO.</b>	<b>NEW PART NO.</b>	<b>OLD PART NO.</b>	<b>DESCRIPTION</b>	<b>VOLTAGE</b>	<b>QTY./ PACK</b>
1	18008	18008	Compact Back Cover only	All	1
2	18005	18005	Thumbscrews for Back Cover (2)	All	2
3	18007	18007	Compact Door Cover only	All	1
4	891	891	Drive Socket Assembly	All	1
4	15546	15546	Drive Socket Assembly (Set of 2)	All	2
4	15547	15547	Drive Socket Assembly (Set of 5)	All	5
5	15579	15579	XP Centering Pad	All	1
6	15771	CST105	Top Motor Plate	All	1
7	15772	FOM164	Thick Top Motor Plate Gasket	All	1
8	15773	FOM163	Donut Gasket	All	1
9	15788	PLS167	In-Counter Upper Housing	All	1
10	15603	15603	In-Counter Housing Gasket	All	1
11	15790	PLS174	Low Voltage Board Holder	All	1
12	15775	n/a	Low Voltage Board Assembly (includes Memory Cable)	All	1
13	15820	CTL198	In-Counter Touch Pad	All	1
14	15686	ASY201	Motor Assembly 3 HP	220/240V	1
14	15682	ASY199	Motor Assembly 3 HP	100/120V	1
15	15789	ASY163	Motor Shroud Assembly	All	1
16	15780	CTL173	High Voltage Board Assembly	120/220/240V	1
16	15781	CTL170	High Voltage Board Assembly	100V	1
17	15793	ASY218	EMI Filter	220/240V	1
18	15782	CTL172	8 Amp Fuse	220/240V	1
19	15783	ASY165	Fuse Holder	220/240V	1
20	15794	PLS170	Electrical Box Cover	All	1
21	15795	PLS171	Electrical Box	All	1
22	15796	STM162	Electrical Box Housing Bracket	220/240V	1
22	15797	STM163	Electrical Box Housing Bracket	100/120V	1
23	15785	CTL805	On/Off Rocker Switch	220/240V	1
23	15786	CTL800	On/Off Rocker Switch	100/120V	1
24	By Country	By Country	Power Cord	220/240V	1
24	15787	PLG134	Power Cord	100/120V	1
25	15745	CTL125	Japanese Adapter	100V	1
26	15743	CON800	Power Cord Strain Relief	220/240V	1
26	15798	CON161	Power Cord Strain Relief	100/120V	1
27	15746	n/a	Memory Cable	All	1