



FOODSERVICE

Owner's Manual

Read And Save These Instructions



T&G2[™] **Blending Station**[®]

High Performance Commercial Blender

All Models

IMPORTANT SAFEGUARDS

1. Read all instructions.
2. To protect against risk of electrical shock, do not put motor base in water or other liquid.
3. Close adult supervision is necessary when appliance is used by or near children.
4. Unplug the power cord from the wall outlet when the T&G 2 Blending Station® is not in use, before putting on or taking off parts, and before cleaning other than washing the container.
5. Never contact moving parts.
6. Do not operate any appliance with a damaged cord or plug or after the appliance malfunctions or is dropped or damaged in any manner. **Call Vita-Mix® Service, (800) 4DRINK4, (800-437-4654) or 440-235-0214** at once for possible replacement, examination, repair, electrical or mechanical adjustment. If you live outside the United States or Canada, contact your local Vita-Mix Distributor, or phone the Vita-Mix International Division at +1 (440) 782-2450 or email international@vitamix.com for a distributor in your country.
7. The use of attachments not recommended or sold by Vita-Mix Corporation may cause fire, shock, or injury.
8. **Do not use outdoors.**
9. Do not let the power cord hang over edge of table or counter, or touch hot surfaces.
10. Keep hands and utensils out of the container while motor is running to prevent the possibility of severe personal injury and/or damage to the T&G 2 Blending Station. A rubber scraper may be used, but only when the T&G 2 Blending Station is not running.
11. **CAUTION: Blade is sharp. Handle carefully.**
 - Never try to remove blade while container is sitting on the motor base.
 - Do not operate with loose, nicked or damaged blades.
 - To reduce the risk of personal injury, never place blade assembly on motor base without blender container properly attached.
12. The maximum normal load is equivalent to the ounces (liters) listed on the container, i.e., 32 oz. (900 ml), and substantially less with thick mixtures.

13. Always operate with the lid in place.
14. Display window area will scratch when contacted with a scouring pad or sharp object. Use a soft cloth to wipe the control panel area clean.
15. The T&G 2 Blending Station® cannot be cleaned with a water jet.
16. Installation for a 120 VAC unit requires you to have at least one 20 amp outlet per machine, available within six feet of the T&G 2 Blending Station. 220 VAC and 100 VAC units require a dedicated line. Consult an electrician for proper electrical needs.

SAVE THESE INSTRUCTIONS

Enjoy the safety of this grounded appliance. The T&G 2 Blending Station U.S. power cord comes equipped with a three-prong (grounding) plug which mates with a standard three-prong wall outlet (Figure A). This cord will vary for countries outside the United States.

Adapters (Figure B) are available for two-prong outlets. Do not cut or remove the third (ground) prong from the plug or power cord.

Consult your electrician if you are not sure if the wall outlet is grounded through the building wiring. With a properly grounded two prong wall outlet, ground the T&G 2 Blending Station by attaching the tab on the adapter to the wall outlet cover by means of the screw in the center of the cover (Figure B).



**THREE PRONG
ADAPTERS ARE
NOT TO BE USED
IN CANADA.**

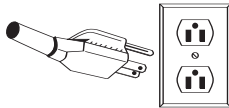

Figure A

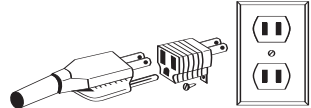

Figure B

Specifications

T&G 2 Blending Station® On-Counter:

Height of unit closed: 22" (54.56 cm)
Shipping weight: 21 lbs. (9.534 kg)
Dimensions: 22" High x 9-1/4" Wide x 10-1/2" Deep
(54.56 cm x 23.45 cm x 25.86 cm)

T&G 2 Blending Station In-Counter:

Height of unit above counter: 17-1/2" (44.45 cm) closed
Depth of unit below counter: 5-2/3" (13.3 cm)
Shipping Weight: 18 lbs. (8.172 kg)
Dimensions: 24" total height x 9" Width x 12-3/4" Depth (45.03 cm x 22.65 cm x 32.39 cm)

NOTE: For In-Counter Installation refer to pages 8-10.

Power Requirements:

Volts: 120 VAC
Amps: 11.5
Hz: 50/60

Volts: 220/240 VAC
Watts: 1073-1178
Hz: 50/60

Volts: 100 VAC (Japan)
Watts: 900
Hz: 50/60

Control Panel

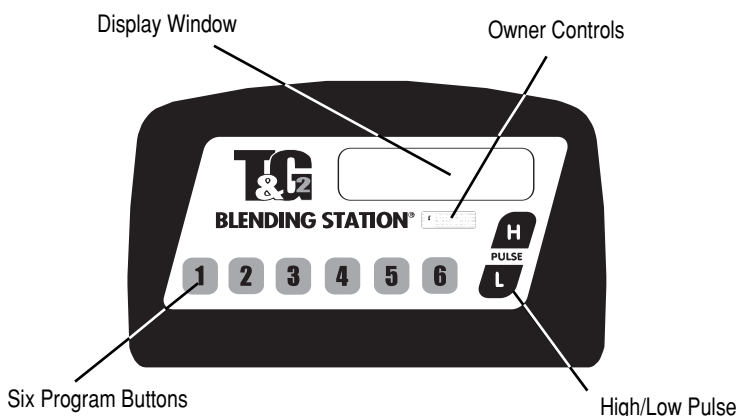

T&G 2 Blending Station®

ON/OFF switch - Located on the side of the motor base the ON/OFF switch controls the power to the machine. With the machine plugged in, switch the machine to ON to ready the machine for blending.

SIX PROGRAM buttons - These buttons, numbered 1 thru 6, are pre-programmed blending cycles designed for the most commonly made drinks. Depending on the viscosity of the drink you are creating, pressing one of the six PROGRAM buttons will run the machine for a full cycle. The machine will stop by itself when the cycle is complete. Or you can press one of the buttons to stop the machine in the middle of a program cycle. Each button can be reprogrammed. See programming instructions on page 11 for more information. A cycle varies in speed and length, see the instructions on page 12 for a complete description of the range of each button. Due to the difference of recipes, your results may vary.

DISPLAY WINDOW - This area depending on what button is pressed, displays a variety of operation messages. A 'READY' message appears when there is power to the machine.

HIGH/LOW PULSE button - The PULSE button provides a quick increase in speed of the blades for refreshing or finishing a drink. Press H to increase the motor speed to 100%. Press L to increase the motor speed to 50%. The PULSE button will override the running program. Once released the original program continues its cycle.

OWNER CONTROLS - Press the Vita-Mix logo to access the T&G 2 Blending Station control panel.

RECIPE 1 - 34

• **Press once** to reveal the option to reprogram the the SIX PROGRAM buttons. See page 11 for instructions.

READY

• **Press twice** to exit programming and continue blending.

PROGRAM ALL TO

• **Press and hold** until screen changes to "PROGRAM ALL TO". See page 11 for instructions.

6 TO RESTORE

• **Press and hold while turning the machine on**, screen changes to "6 TO RESTORE". Press the number six button to clear the settings of the machines six programmed buttons and restore them to their original factory settings. Follow the instructions on page 11 to re-program the buttons.

Lid Assembly

NOTE: Outside the United States and Canada, your T&G 2 Blending Station may come with a different container configuration.

Two-part Lid

32 oz. (900 ml) Xtreme Performance Container

The two part lid is easy to clean and easy to put on, take off & seal.

- To remove a fully latched lid, lift the two tabs and pull upward and off.
- Twist the center lid plug to fasten or remove.



Figure A

Older 48 oz (1.4 liter) and 64 oz (2.0 liter) Vita-Mix containers will work on the T&G 2. The Xtreme Performance Container (XP) will not work on older Vita-Mix Machines. Contact Vita-Mix or your distributor for more information.

One Piece Lid (optional)

32 oz. (900 ml) Xtreme Performance Container

The one piece lid is easy to clean and easy to put on and take off.

- There is no lid plug for this lid.
- Add ingredients through port on top.



Figure B

Cover with Removable Hinge Design

Cover Door:

1. The Cover Door can be removed by opening it until the door is horizontal. Then, gently spread the sides of the door over the round hinges and remove.
2. To reinstall the Cover Door, gently spread the sides of the door and place the door hinge cutouts over the round hinges. (Figure C)

Back Cover:

1. To remove the Back Cover from the Blending Station:
 - a. First remove the Cover Door from the unit, as described above.
 - b. Remove the two (2) Back Cover mounting screws located on the rear of the machine. (Figure D)
 - c. From the rear of the machine, firmly push the bottom of the cover forward (towards the control panel), keeping the bottom edge of the cover against the motor base. **DO NOT tilt or strike the cover during removal.**
 - d. Slide forward until the side latches on the front of the cover are released from the motor base. **DO NOT strike the cover to “pop” the side latches from their tracks. Doing so will cause damage. The cover must only be removed by sliding it forward (toward the Control Panel).**
2. To replace the Back Cover on to the Blending Station:
 - a. Place the Back Cover on the motor base approximately one (1) inch forward of its normal position.
 - b. Slide the cover towards the back of the machine (away from the Control Panel). **Make sure the side latches slide into their tracks.**
 - c. Push until back of cover is seated against the Motor Base. **Make sure the Back Cover is fully seated in the back and the side latches are in their grooves before inserting and tightening the mounting screws.**
 - d. Replace and firmly tighten the two (2) Back Cover mounting screws. (Figure D) **DO NOT overtighten. DO NOT use the mounting screws to pull the Back Cover into position. Doing so will cause damage.**

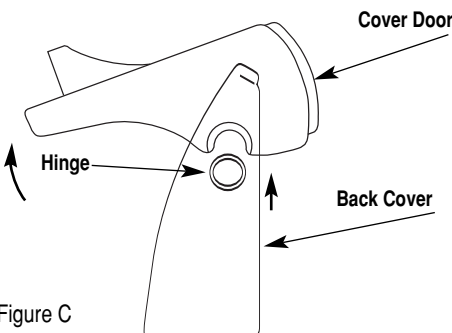

Figure C

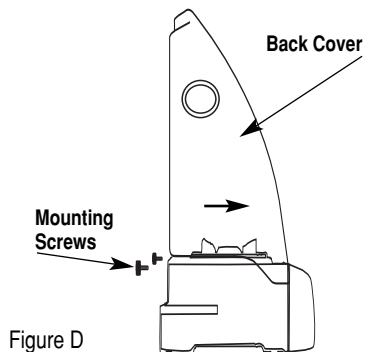

Figure D

In-Counter Installation

Preparing the counter area:

- Before cutting holes, make sure that there is adequate clearance under the counter for the motor. The motor will extend about 5-2/3" (14.4 cm) below the counter but it is best to allow at least 10" (25.5 cm) from the under-counter to shelves or any other equipment under the counter. Also, when using the removable cover design, the back of the hole must be at least 6" (15.2 cm) from any wall to allow for cover door clearance.
- An extra 6.5" (16.5 cm) of open space, above the top of the cover will be needed for placement and removal of the In-Counter machine and for custom programming the SIX PRE-SET buttons.
- If installing unit into a closed cabinet, use a 4" dia. (10 cm) flexible vinyl duct (dryer hose) to vent exhaust. Attach the vinyl duct to the bottom of your In-Counter T&G 2 Blending Station® by forcing the end of the hose over the exhaust baffle of the unit. Run the vinyl duct out of the cabinet for proper ventilation. Do not vent hose into a wall, ceiling, or a concealed space of a building. Multiple units should not vent to a common manifold unit but to separate places. If running your In-Counter T&G 2 Blending Station causes a suction on your cabinet door, place a spacer in the door frame to allow proper intake of air.



DO NOT use hose clamps or equivalent to attach exhaust hose on machine.

- When cutting holes for placement of multiple In-Counter units, position the edge of the machines at least 12" (30.48 cm) apart to ensure quick cleaning and proper venting between machines.
- In-Counter installation for 120 VAC unit also requires you to have at least one 20 amp outlet per machine under the counter, available within six feet of the T&G 2 Blending Station. 220 VAC and 100 VAC units require a dedicated line. Consult an electrician for proper electrical needs.
- The In-Counter T&G 2 Blending Station also requires a gasket (provided in the machine's original package) to be placed between the machine and the counter. See page 10 for instructions.



DO NOT strike the blender when removing from the counter.

Electrical requirements:

- 120 VAC • 50/60 Hz. • 11.5 amps
All 120 VAC T&G 2 Blending Stations are built using a U.S. 3 prong grounded cord and require a 20 amp outlet.
- 220/240 VAC • 50/60 Hz. • 1073-1176 Watts
- 100 VAC (Japan) • 50/60 Hz. • 900 Watts

In-Counter T&G 2 Blending Station® dimensions:

- 17-1/2" (44.45 cm) high with lid closed
- 21-1/2" (54.7 cm) high with lid open
- Case depth: 12-3/4" (32.39 cm) with handle
- Case width: 9-1/2" (24.13 cm)
- Depth below counter: 5-2/3" (14.4 cm)
- Recommended distance between machines: 12" (30.48 cm) from the edge of each machine or as far apart as possible.

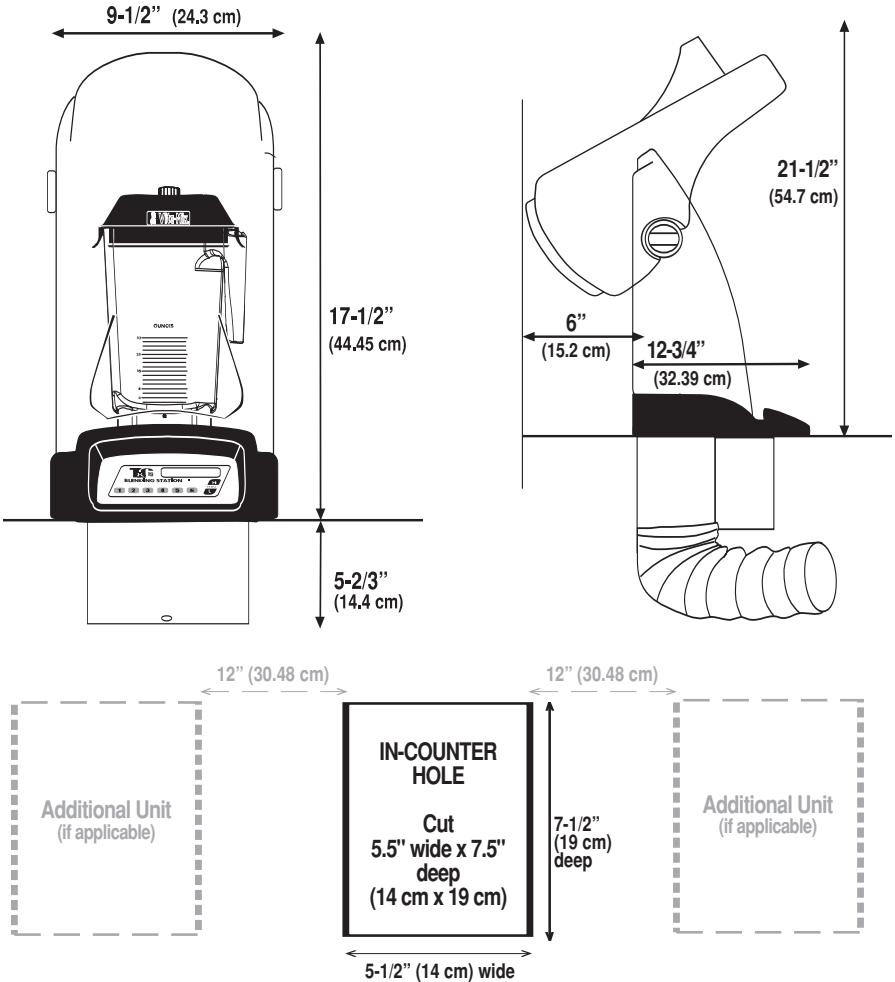

In-Counter Gasket

Gasket Installation Instructions:

1. Follow the instructions on page 8 on preparing the counter area for the installation of your In-Counter T&G 2 Blending Station®. Also, use the Template Sheet (provided in your machine's original package) to assist you in the placement and ventilation of your machine.
2. Lay the blender on its back with the motor pointing toward you. Allow 1-2 in. (2.54 -5.08 cm) of the motor base to hang over the edge of the counter top to facilitate easy fitting of the gasket.
3. Slide the power cord through the gasket, with the groove of the gasket pointing toward the machine base.
4. Starting at one corner of the motor base, press the gasket onto the motorbase, so that the groove in the gasket seats itself onto the stepped bottom edge of the motor base.
5. Working around the bottom edge of the motor base, press the gasket onto the motor base until the entire perimeter of the gasket is firmly attached to the motor base.
6. Carefully place the blender into the hole in the counter.
7. Be sure that the gasket is properly seated on the motor base and against the counter top.
8. Do not secure the machine to the counter with bonding materials.



This gasket was designed to protect your machine from water damage and to reduce noise. Failure to properly install this gasket could result in moisture damage.

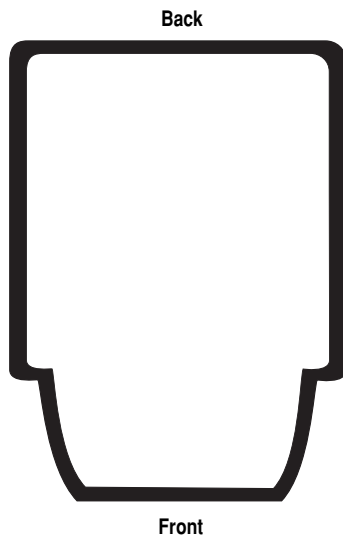

Custom Programming

The T&G 2 Blending Station® advanced electronic control can be custom programmed by using the control panel. The two different programming instructions are explained below:

Programming One of the Six T&G 2 Blending Station PRE-SET buttons

1. Press the OWNER CONTROL button (Vita-Mix Logo).
2. Press the PULSE High/Low buttons to scroll thru the 'RECIPE' numbers.
3. Press the number of the button for programming. (For a description of each recipe refer to *T&G 2 Blending Station 34 Programming Options* insert included with your machine.)

For Example: If you wanted to program Button One with Recipe #17

1. After pressing the OWNER CONTROL button. The DISPLAY SCREEN will say "RECIPE 1-34".
2. Then repeatedly press the "H" PULSE button until the screen displays "RECIPE #17".
3. Then press the ONE button to apply Recipe #17.
4. Either continue programming the other five buttons or press the OWNER CONTROL button to exit and continue blending.

RECIPE 1 - 34
RECIPE #1

RECIPE 1 - 34
RECIPE #17

RECIPE 1 - 34
RECIPE #17 ---->1

READY

Re-Programming ALL Six T&G 2 Blending Station Buttons to the same program



Re-programming all of the buttons will erase any individual programs set using the instructions above.



1. Press the OWNERS CONTROL button (Vita-Mix Logo) and HOLD until "REPROGRAM ALL" appears on the screen.
2. Press Button One to Six to re-program all the buttons to a family of similar blending cycles.

- Press Button One for program SMOOTHIE -
Blends drinks with just juice and ice.

PROGRAM ALL TO
SMOOTHIE PRESS 1

- Press Button Two for program SMOOTH 2 -
Blends regular smoothies for an extended cycle.

PROGRAM ALL TO
SMOOTH 2 PRESS 2

- Press Button Three for program COFFEE-
Blends light coffee drinks.

PROGRAM ALL TO
COFFEE PRESS 3

- Press Button Four for program SHAKES -
This cycle is good for ice cream and milkshakes.

PROGRAM ALL TO
SHAKES PRESS 4

- Press Button Five for program COCKTAIL-
Blend margaritas, daiquiris.

PROGRAM ALL TO
COCKTAIL PRESS 5

- Press Button Six for program OTHER -
Specialty drinks, using frozen fruit and other hard ingredients for a thick but consistent drink.

PROGRAM ALL TO
OTHER PRESS 6

I nstructions

How to operate your T&G 2 Blending Station® using the six Programmed Buttons.

The following is the basic factory settings of the six PROGRAMMED buttons:

- 1** • Press Button One for program - SMOOTHIE - *Blends drinks with just juice and ice.*
- 2** • Press Button Two for program - SMOOTH 2 - *Blends regular smoothies for an extended cycle.*
- 3** • Press Button Three for program - COFFEE - *Blends light coffee drinks.*
- 4** • Press Button Four for program - SHAKES - *This cycle is good for ice cream and milkshakes.*
- 5** • Press Button Five for program - COCKTAIL - *Blend margaritas, daiquiris.*
- 6** • Press Button Six for program - OTHER - *Specialty drinks, using frozen fruit and other hard ingredients for a thick but consistent drink.*

1. Place liquids and soft foods in the machine's container first, solid items and ice last. Prepare food by cutting or breaking into 1-3 inch (3-8 cm) pieces. Frozen fruit, especially, should be as small as practical. Thawed or partially thawed fruit is recommended. We recommend Programmed Button Five or Six for heavy-duty blending.
2. Set the container on the motor base by aligning it over the centering pad anchored to the base. (**Motor must be completely stopped before positioning container**). Containers are not to be used for hard, dry materials. Avoid running the machine with an empty container.
3. Always use a lid when blending. If blending hot ingredients, the lid must be securely in place.
4. Select desired programmed setting by pressing any of the Pre-Set Buttons One through Six. The machine will begin immediately to cycle through the selected program, and turn off when the program is complete. Each button has a different pre-selected combination of speed and length for blending.

NOTE: If you detect a change in the sound of the machine or if a hard or foreign object comes into contact with the blades, do not serve the drink. Inspect your blade assembly for loose, knicked or missing parts. If parts are loose, missing or knicked replace with a new blade assembly. (See page 20).

5. Once one of the six PROGRAMMED Buttons is pushed the machine will start and stop automatically. By pressing another PROGRAMMED Button, the machine will stop the blending cycle.
6. During any of the blending cycles, by pressing the PULSE H button the speed of the blending can increase up to 100% of the motor speed. By pressing the PULSE L button during a blending cycle the speed of the motor will be increased/decreased to 50%. Once released the motor speed will revert back to the blending cycle of the PRE-SET PROGRAM.

7. When the cycle is complete the blender stops. **Wait until blade comes to a complete stop before removing the lid and/or container from the motor base.**
8. Remove the container, pour, garnish and serve the drink.

NOTE: On all units the built-in thermal sensor keeps track of how hot the motor gets and will warn the user and eventually shut down the motor if the motor is overheating. When overheated the display will instruct the user to remove the container and run the machine until cool. This takes about a minute. See page 19, "Cooling the Motor," for complete instructions.

When overheating occurs, review your techniques and instructions. The motor may be getting hot when your recipes are too thick. Consider adding more liquid and consult Vita-Mix for further assistance.

Blending Tips:

1. If your recipe freezes up, try reducing the amount of ice. Compared to other blenders, you do not need as much ice to make an equally frozen drink in a T&G 2™ Blending Station.®
2. Place liquids and soft foods in your container first. Hard items and ice should be placed last.
3. Whole, hard or frozen ingredients should be small. Solid frozen fruit is extremely difficult to blend. For best results use semi-frozen fruit. Using same size batches of semi-frozen fruit and ice will keep your drinks consistent. If you notice chunks, re-evaluate the batch size.
4. When creating recipes, always allow for enough liquid to ease the blending process.

Maintenance Tips:

- **NEVER** bang the container against a surface to loosen the ingredients. Remove the container from the base and use a rubber spatula to remove thick mixtures from the bottom of your container.
- **NEVER** shake or rattle a container while in use.
- **NEVER** remove the container before the machine has come to a complete stop.
- **NEVER** start the motor before the container is in place.



The instructions appearing in this Owner's Manual cannot cover every possible condition and situation that may occur. Common sense and caution must be practiced when operating and maintaining any appliance.

Parts List

Item#	Part
#15573	32 oz. (900 ml) - XP Container without lid assembly or blade assembly
#15571	32 oz. (900 ml) - XP Container, blade assembly, no lid assembly
#1159	32 oz. (900 ml) - Lid plug
#15570	32 oz. (900 ml)- XP Container, blade assembly & lid assembly
#15574	32 oz. (900 ml) - 2-piece lid assembly for XP Container
#15575	32 oz. (900 ml) - Lid only (no plug) for XP Container
#18002	Back cover and cover door with removable hinge design
#18003	Cover door with removable hinge design
#18004	Back cover with removable hinge design
#15579	Sound-reducing XP centering pad
#891	Drive socket
#15585	XP retainer nut for XP Containers
#15598	XP Blade agitator assembly
#18005	Metal Screws - (2)
#15603	In-Counter Gasket

NOTE: Blade Assembly, Drive Socket and Retainer Nut are not compatible on other Vita-Mix polycarbonate or stainless steel containers. Other than the Drive Socket, Blade Assembly and Retainer Nut, this unit is not user serviceable.

Outside the United States and Canada, your T&G 2 Blending Station® may come with a different container configuration. Contact your local Vita-Mix distributor for part numbers.

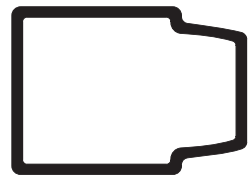
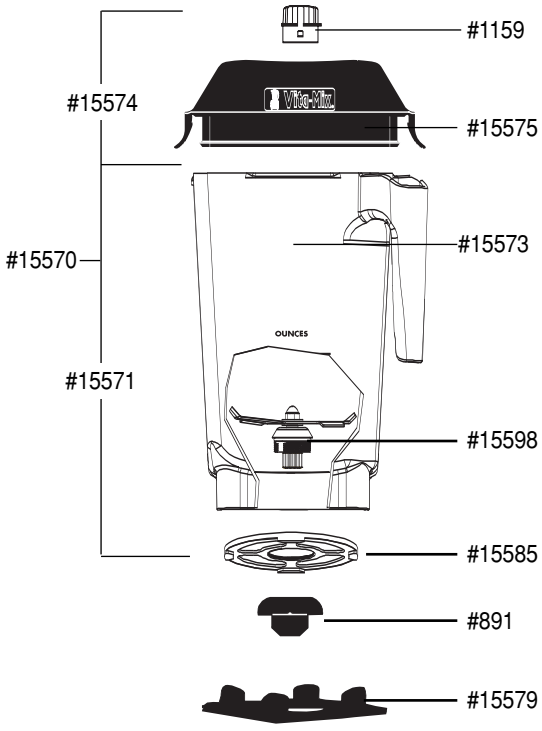

#15603



#15576
One-Piece Lid
(Sold Separately)

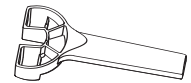

#15596 -
Retainer Nut Wrench
(Sold Separately)

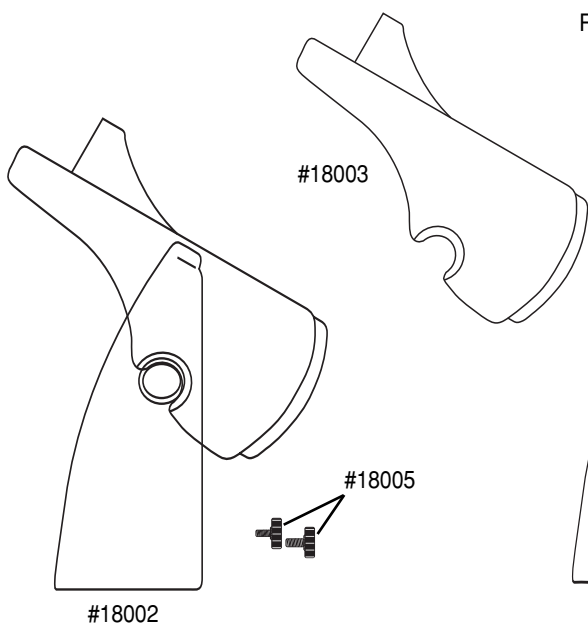

Care and Cleaning

Care Note

To ensure that you get the longest possible life from your Vita-Mix product, we recommend the following products, when used as directed by the supplier:

Cleaning Product

	Supplier
Solid Supra, Solid Power,	Ecolab, Inc. , St. Paul, MN
Guardian Acclaim, Solid Guardian Plus,	Tel: (800) 352-5326
Solid Super Impact, Solid Insure	www.ecolab.com
Diverpak	Diversey , Livonia, MI
Eclipse H2, Liqui-Safe L7	(800) 521-8140
Acclean.....	Klenzade Products
Poly-Brite	Division of Ecolab
	St. Paul, MN
	(612) 293-2165
Glow MB-1	Wesmar Company, Inc.
Lustre NC-25	Seattle, WA
Lustre Plus	(206)783-5344
	www.wesmar.com
PSRA 41-D, PSRA 41-E	Anderson Chemical Co.
Liqui-Ware 1, Liqui-Ware MC	Litchfield, MN
D-Flex, Sur-Met	(800) 366-2477
	www.andersonchemical.com

Rinse Aids

	Supplier
Solid Rinse Dry.	Ecolab, Inc. , St. Paul, MN
Solid Brilliance	Tel: (800) 352-5326
Jet Dry, Rinse Dry	www.ecolab.com

Destainer

	Supplier
NuWare	Diversey , Livonia, MI
	(800) 521-8140



DO NOT use abrasive cleaning agents or concentrated bleach when cleaning. DO NOT use any cleaners containing Quaternary Sanitizers on polycarbonate components (i.e., containers).

CARE NOTE: Do not let mixtures, liquids and food products dry within the container. Rinse throughout use. Drying product may lock around the blade and weaken/tear the bearing's seal when restarted. Do not place containers in the freezer. Extremely low temperatures combined with hot ingredients and/or the immediate rapid action of the blade may crack the container.

Motor Base

1. Unplug the power cord.
2. Wash outside surface with a damp soft cloth or sponge, which has been rinsed in a mild solution of liquid dish soap (Ivory Liquid® or equivalent) in warm water. **NEVER IMMERSE MOTOR BASE IN WATER OR OTHER LIQUID. NEVER POUR WATER OR ANY OTHER LIQUID ON THE MOTOR BASE.**
3. Polish with a soft cloth.

Control Panel

Gently wash the front panel with a soft cloth and a low pH balanced soap, being careful not to scratch the Display Window. **NOTE: Be sure to wring excess water out of cloth or sponge when cleaning around the controls, drive socket or any electrical part.**

Lid

Separate the lid and plug, then wash in warm soapy water. Rinse clean under running water and dry. Reassemble before use. (See page 6).

Cover Door

The cover can be removed (See page 7) and cleaned by placing under running water and washed with a soft cloth. Wipe dry and replace back on the base. **DO NOT wash cover door in dishwasher.**

In-Counter Gasket

Carefully remove the gasket from under the blender (In-Counter Blending Station only). Wash the gasket in warm, soapy water, rinse clean and let dry. Reassemble before use (see page 10). **Make sure the gasket is seated properly against the blender and counter.**

Container

NOTE: For maximum container life do not wash in dishwasher.

1. To clean: Fill pitcher with 8-10 oz (250-300 ml) of warm (110°F/43°C) water and add a couple drops of dish soap. Return container to motor base and firmly position the two part lid. Run machine for 30 seconds. Empty container. Repeat this step.
2. Fill pitcher with 8-10 oz (250-300 ml) of warm (110°F/43°C) water (do not add soap). Return container to motor base and firmly position the two part lid. Run machine for 30 seconds. Empty container.
3. If any solid residue remains, remove the blade agitator assembly (see pg. 20) and wash all container parts in warm soapy water. Rinse and drain. Reassemble before next step.

NOTE: DO NOT soak the blade agitator assembly.

4. To sanitize: If all solid residue is gone after Step 2 or after completion of Step 3, fill container with 8-10 oz (250-300 ml) of a sanitizing solution mix.* Return container to motor base and firmly position the two part lid. Run machine on HIGH (Press the PULSE 'H' button) for 30 seconds. Empty container.
5. Return container to motor base and run machine empty for an additional 5 seconds. Do not rinse after sanitizing.

*Recommended sanitizing solution: 1-1/2 teaspoons Clorox® or other institutional bleach with 8-10 oz. (250-300 ml) of water.



Important: Check your blades daily for loose, nicked or missing parts. If you find something is loose, nicked or missing, replace the blade assembly before use. Do not tighten hex-headed screw (on top of blade assembly). If loose, replace blade assembly.

Troubleshooting

Top nine problems you can fix on your own:

1. Problem:

- Display Panel reads

HEATING SENSOR FAILURE

Solution #1:

Turn the machine off and on again to reset the programming.

Solution #2:

Call Vita-Mix Customer Service.*

2. Problem:

- Loud noise from blender container blade area
- Container blades do not spin
- Increased vibration
- Leaking from bottom of container

Solution #1:

Broken or worn Drive Socket. Replace (Item # 891). Instructions are included with part.

Solution #2:

Check blade assembly for loose, damaged or nicked components and replace.

Solution #3:

Tighten retainer nut on the bottom of the container.

3. Problem:

- Loud grinding noise from the blender motor

Solution #1:

Due to some faulty motor bearings your machine may need to be repaired. Call Vita-Mix Customer Service.*

4. Problem:

- Machine will not run
- Display screen does not say 'READY'

Solution #1:

Double-check to make sure power cord is firmly in power outlet.

Solution #2:

Check to make sure the ON/OFF switch is in the ON position.

Solution #3:

Turn the ON/OFF switch to off, then on, to reboot the electronics.

5. Problem:

- Machine starts then shuts off

Solution #1:

Check to make sure there is power to the machine.

Solution #2:

Call Vita-Mix Customer Service.*

6. Problem:

- Display Panel reads

MOTOR LOCKED PROGRAM
TERMINATED

Solution #1:

Let the machine cool down for an hour then restart.

Solution #2:

Call Vita-Mix Customer Service if the machine does not work after sitting at room temperature for 24 hours.*

7. Problem:

- Machine is running irregular
- “NO PROGRAM” is displayed when a button is pushed
- Button pressed starts the wrong program
- Machine starts by itself
- A specific program button is defective
- Machine was turned off for a day, week or month and turned on, there was no power
- Machine did not work right out of the box
- Machine works but no information displayed on screen
- Program buttons run the blender on the same speed

Solution #1:

Turn the machine off and on again to reset the programming.

Solution #2

Reset the machine to its original factory settings. (Follow the instructions on page 7)

Solution #3:

Try plugging the machine into a new outlet.

Solution #4:

Call Vita-Mix Customer Service.*

8. Problem:

- Display panel reads



CORRUPT DATA

Solution #1:

A new programming chip is needed. Call Vita-Mix Customer Service.*

9. Problem:

- Machine stops in the middle of its blend cycle and resets; display panel reads “VITA-MIX GENERAL PROGRAM” then “READY”

Solution #1:

Plug the machine into its own power supply.

Solution #2:

Make sure the machine is not running on a long extension cord.

*Outside the United States and Canada, contact your local Vita-Mix Distributor.

Cooling the motor:

If the machine has overheated:



MOTOR HAS OVERHEATED...
HOT SHUTDOWN

- The motor will stop and the message “MOTOR HAS OVERHEATED REMOVE THE CONTAINER, THEN PRESS START”, will scroll across the display window, while the words “HOT SHUTDOWN” will remain in the display window alerting you of the problem.
- The machine will not run until the container is removed and the motor has cooled. Remove the container, shut the cover door and press the START/STOP button, and run the machine for two minutes.
- When the motor is cool “READY” will appear in the display window.



READY

If you cannot fix your machine with these suggestions, technical help is available by calling 800-4DRINK4 (800-437-4654), 440-235-0214. Outside the United States and Canada contact your Vita-Mix distributor or contact Vita-Mix International at +1(440) 782-2450 or email international@vitamix.com for a local distributor or visit us at www.vitamix.com/foodservice.

Blade Agitator Assembly

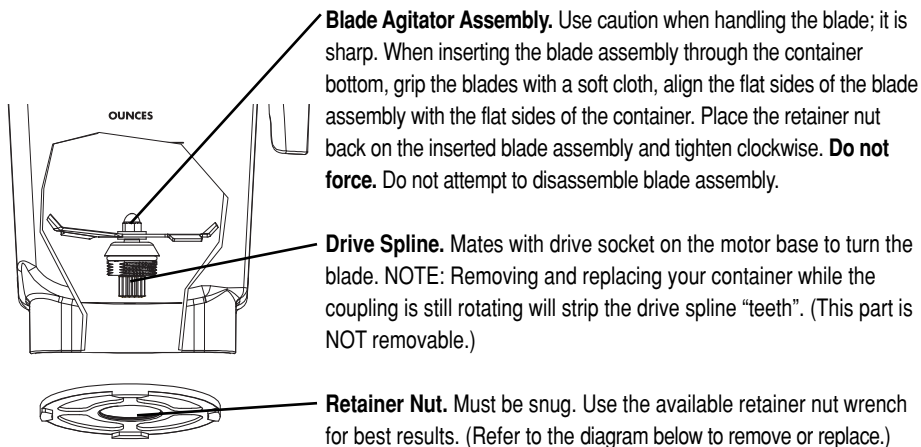

Never use a blade assembly with loose, damaged or nicked components.

Retainer Nut Removal

- The retainer nut is easily removed using the Retainer Nut Wrench. To order a Retainer Nut Wrench please call your Vita-Mix distributor and ask for Item #15596.
- To remove, turn the container upside. Using the Retainer Nut Wrench turn the wrench counterclockwise to loosen the nut. Once loosened, remove by hand.
- To replace, position retainer nut on top of blade assembly and hand tighten. Then, using the Retainer Nut Wrench, tighten clockwise until it stops. If it is not tight enough, you will notice increased container noise.

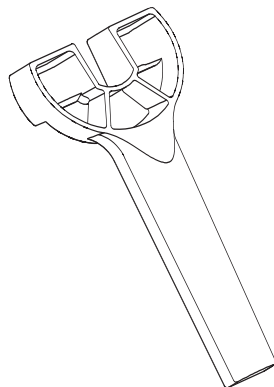

Retainer Nut Wrench

Warranty

Limited Warranty

Vita-Mix® Corporation warrants your Commercial T&G 2™ Blending Station® to be free from defects in materials and workmanship for a period of three years from the date of purchase when used in accordance with the accompanying instruction booklet.

Provisions of this limited warranty are void if your T&G 2 Blending Station has been subjected to obvious abuse, neglect, accident, alteration, or failure to follow operating instructions, or product exposure to abnormal or extreme conditions. Cosmetic changes such as discoloration of parts of the product in the hands of the user or the effects of the use of abrasive cleaners will not be warranted or considered defects. The cleaning or removal of food products along with any damage caused by allowing them to build-up is not covered by this limited warranty. Improper installation of the In-Counter model is not covered by this warranty. Also this warranty is void if the T&G 2 Blending Station is put into a sound reduction chamber or otherwise prevented from receiving proper cooling. In the event your Vita-Mix appliance needs service or repair covered by the terms of this warranty, please call the Vita-Mix Corporation for shipping instructions. The T&G 2 Blending Station must be sent in original or sufficient packaging.

This limited warranty is in lieu of any other warranty expressed or implied. No representative or any other person is authorized to make any other warranty or to assume any liability not strictly in accordance with the foregoing. This limited warranty gives you specific legal rights which may vary from state to state. Proof-of-purchase may be required to prove date of purchase.

Outside the Continental United States and Canada other warranties may apply. (Call or check with your local Vita-Mix distributor for details.) In case of shipping damage, notify the shipper or carrier immediately.

Service Contract

PLEASE NOTE: The Service Contract outlined in the following paragraph applies only to customers in the United States and Canada. Customers in all other countries should contact their local Vita-Mix distributor for service details.

This T&G 2™ Blending Station® includes a 1-Year Service Contract effective from date of purchase. In the event your machine should need parts or repairs, covered under this Service Contract, call Vita-Mix® customer service immediately for instructions. Proof of date of purchase may be required. This does not cover abuse, misuse, tampering, improper installation or extreme conditions.

The Vita-Mix Service Contract includes the following:

1. Only one extra drive socket - to facilitate simple repairs and prevent down time is included and packaged with each machine.
2. Additional drivers and tamper, unless defective and cosmetic changes, such as discoloration of parts are not covered. **NOTE:** to determine if you have a defective part, please order a replacement part through Vita-Mix Customer Service, and when the new part arrives, return the old part in the same packaging. Vita-Mix will inspect the returned part and, if defective, issue a refund for the price of the new part. A part will be considered defective if no abuse or neglect was involved with its break. Non-defective parts sent to Vita-Mix for inspection will not be returned if deemed unusable. Service Contract covers functionality of the machine but not abuse or lack of recommended maintenance.
3. In Continental USA, sender pays freight one way to Vita-Mix Corporation. Vita-Mix Corporation pays UPS ground freight charges to return machine to sender. Sender pays costs for special shipping requests. Outside Continental USA, other service contracts may apply.

Before returning this product for any reason, including repair, please, first contact our Customer Service Department at: (800) 4DRINK4, (800-437-4654) or 440-235-0214 to receive a "Return Authorization Number." Outside the USA, contact your Vita-Mix Distributor.

NOTE: Within the United States Limited Warranty and Service Contract are honored directly through the Vita-Mix Corporation, Cleveland, Ohio USA. Non-warranty repairs can be performed by any CFESA service center. Call Vita-Mix at (800) 4DRINK4 (800-437-4654) or 440-235-0214.



VITA-MIX® CORPORATION
Foodservice Division

8615 Usher Road, Cleveland, Ohio 44138-2103 USA
www.vitamix.com/foodservice

©2005 Vita-Mix Corporation. No part of this publication may be reproduced or transmitted in any form or by any means, electronic or mechanical, including photocopy, recording or any information storage and retrieval system without the written permission of the Vita-Mix Corporation.