



FOODSERVICE

Owner's Manual

Read And Save These Instructions



Touch & Go[®] Blending Station[®]

High Performance Commercial Blender

All Models

IMPORTANT SAFEGUARDS

1. Read all instructions.
2. To protect against risk of electrical shock, do not put motor base in water or other liquid.
3. Close adult supervision is necessary when appliance is used by or near children.
4. Unplug the power cord from the wall outlet when the Touch & Go® Blending Station® is not in use, before putting on or taking off parts, and before cleaning other than washing the container.
5. Never contact moving parts.
6. Do not operate any appliance with a damaged cord or plug or after the appliance malfunctions or is dropped or damaged in any manner. **Call Vita-Mix® Service, (800) 4DRINK4, (800-437-4654) or 440-235-0214** at once for possible replacement, examination, repair, electrical or mechanical adjustment. If you live outside the United States or Canada, contact your local Vita-Mix Distributor, or phone the Vita-Mix International Division at +1 (440) 782-2450 or email at international@vitamix.com for a distributor in your country.
7. The use of attachments not recommended or sold by Vita-Mix Corporation may cause fire, shock, or injury.
8. **Do not use outdoors.**
9. Do not let the power cord hang over edge of table or counter, or touch hot surfaces.
10. Keep hands and utensils out of the container while motor is running to prevent the possibility of severe personal injury and/or damage to the Touch & Go Blending Station. A rubber scraper may be used, but only when the Touch & Go Blending Station is not running.
11. **CAUTION: Blade is sharp. Handle carefully.**
 - Never try to remove blade while container is sitting on the motor base.
 - Do not operate with loose, knicked or damaged blades.
 - To reduce the risk of personal injury, never place blade assembly on motor base without blender container properly attached.
12. The maximum normal load is equivalent to the ounces (liters) listed on the container, i.e., 64 oz. (2.0 liter), 48 oz. (1.4 liter), and substantially less with thick mixtures.
13. Always operate with the lid in place.

14. **WARNING:** When processing hot liquids:
- The 2-part latching lid must be securely in place. This allows steam to escape naturally, and will prevent the lid from coming off when the machine is turned on.
 - Use caution with hot liquids. Spraying from under the lid plug can occur, or escaping steam may cause scalding.
 - Do not process hot liquids with the non-latching lid.
15. Display window area will scratch when contacted with a scouring pad or sharp object. Use a soft cloth to wipe the control panel area clean.
16. The Touch & Go® Blending Station® cannot be cleaned with a water jet.
17. Installation for a 120 VAC unit requires you to have at least one 20 amp outlet per machine, available within six feet of the Touch & Go Blending Station. 220 VAC and 100 VAC units require a dedicated line. Consult an electrician for proper electrical needs.

SAVE THESE INSTRUCTIONS

Enjoy the safety of this grounded appliance. The Touch & Go Blending Station U.S. power cord comes equipped with a three-prong (grounding) plug which mates with a standard three-prong wall outlet (Figure A). This cord will vary for countries outside the United States.

Adapters (Figure B) are available for two-prong outlets. Do not cut or remove the third (ground) prong from the plug or power cord.

Consult your electrician if you are not sure if the wall outlet is grounded through the building wiring. With a properly grounded two prong wall outlet, ground the machine by attaching the tab on the adapter to the wall outlet cover by means of the screw in the center of the cover (Figure B).



**THREE PRONG
ADAPTERS
ARE NOT TO
BE USED IN
CANADA.**

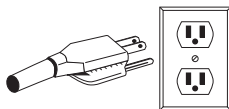

Figure A

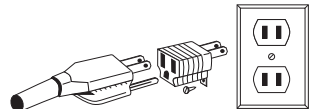
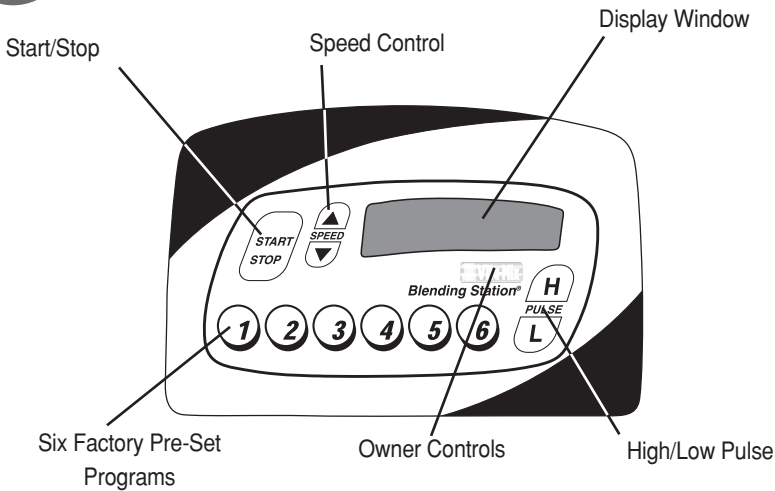

Figure B

Control Panel



Touch & Go® Blending Station®

ON/OFF switch - Located on the side of the Motor Base the ON/OFF switch controls the power to the machine. With the machine plugged in, switch the machine to ON to ready the machine for blending.

START/STOP button - Pressing START/STOP once starts and runs the machine and turns the blades. Press the START/STOP button again to stop the machine and the blades.

(NOTE: Pressing one of the PRE-SET PROGRAM buttons, while the motor is running, will also stop the machine.)

SPEED CONTROL button - Press the ▲ button to gradually increase the speed of the blades in increments of 1%, up to 100%. Press the ▼ button to gradually decrease the speed of the blades in increments of 1%, down to 7%. SPEED CONTROL is used to set the blending speed of the PULSE buttons (See Instructions, pg.15) and the START/STOP button (See Instructions, pg. 16). **NOTE:** These settings will reset if the power is shut off.

PRE-SET PROGRAM* buttons - These buttons, numbered 1 thru 6, are pre-programmed blending cycles designed for the most commonly made drinks. Depending on the viscosity of the drink you are creating, pressing one of the six PRE-SET PROGRAM buttons will run the machine for a full cycle. The machine will stop by itself when the cycle is complete. A cycle varies in speed and length, see the Instructions on page 14 for a complete description of the range of each PRE-SET button. Due to the difference of recipes, your results may vary. See page 6 for information on Custom Programming these six buttons.

DISPLAY WINDOW - This area depending on what button is pressed, displays a variety of operation messages. A 'Ready' message appears when there is power to the machine.



**Your machines PRE-SET PROGRAM buttons function and times may be different then described in the owners manual due to your machine being custom programmed.*

OWNER CONTROLS - A control panel accessible by pressing the Vita-Mix logo.

MODE

- **Press once** to reveal the mode message. Press button 1 then 6 within five seconds to continue. Once the correct code is entered the display will indicate the motor temperature (Norm, Warm, Hot), a usage count and a total. The 'count' is a machine usage total and can be reset. This can be used to keep a count of the number of drinks sold in a week, day or even an hour. To clear, press and hold the START/STOP button for 5 seconds. The 'total' keeps track of the machine usage, including production and testing, and cannot be cleared.

TEMP	COUNT	TOTAL
NORM	25	100

VITA-MIX BASIC PROGRAM

- **Press twice** to reveal the name of the program controlling the PRE-SET buttons. If you are using the factory settings this will read VITA-MIX BASIC PROGRAM.

4 TO OVERRWRITE CURRENT PROGRAM

- **Press a third** time to reveal an option to reset the PRE-SET buttons to the original factory settings.
- **Press a fourth** time to exit and continue blending.

HIGH/LOW PULSE button - The pulse provides a quick increase or decrease in speed of the blades when blending. Press H to increase the motor to speeds that range from 51%-100%. Press L to decrease the motor speed down to a range of 50% -7%. The PULSE button will override the running program (as long as it is depressed). Once released the original program continues its cycle.

- The PULSE high(H) and low(L) speed is set by using the SPEED CONTROL buttons. To set, while pressing and holding a PULSE button, press the SPEED CONTROL ▲ or ▼ button until the desired motor speed is reached. The PULSE speed will remain at this setting until changed again with the SPEED CONTROL buttons.

Custom Programming

The Touch & Go® Blending Station® advanced electronic control can be custom programmed,* requiring an optional programming chip, available from Vita-Mix for a nominal fee and with a minimum unit purchase. Contact your Vita-Mix representative for more information.

Programming your On-Counter Touch & Go Blending Station PRE-SET buttons

1. Turn the machine on.
2. Facing the front of the machine, insert the custom programmed chip with the words, "THIS SIDE FACING TO THE FRONT OF THE MACHINE" toward you and the silver contact bars up, into the port located below the label area on the front of the Touch & Go Blending Station. The DISPLAY WINDOW will read 'New Module'.
3. Within 10 seconds the SIX PRE-SET buttons will be re-programmed and the DISPLAY WINDOW will read 'Saved' then 'Ready'. If nothing happens when the programming chip is fully inserted, turn the chip in the opposite direction and try again.
4. Remove the programming chip and return it to the original package.
5. Press one of the six PRE-SET buttons to reveal, in the DISPLAY WINDOW, the name of the program/drink.*

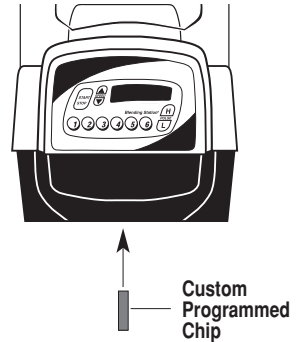

NOTE: If for any reason the programmed times are incorrect, they can be reset to the original factory settings following the instructions on page 7.

Programming your In Counter Touch & Go Blending Station PRE-SET buttons

1. Remove the container from the machine.
2. Turn the machine on.
3. Lift the machine from the bottom edges to reveal the motor and housing area. With the machine facing towards you, locate the slot underneath on the right hand side of the machine between the motor and the outer wall.
4. Insert the custom programmed chip into the slot with the words, "THIS SIDE FACING TO THE FRONT OF THE MACHINE" turned facing out to the right of the machine. Once inserted the DISPLAY WINDOW will read 'NEW MODULE'.

5. Within 10 seconds the SIX PRE-SET buttons will be re-programmed and the DISPLAY WINDOW will read 'Saved' then 'Ready'. If nothing happens when the programming chip is fully inserted, turn the chip in the opposite direction and try again.
6. Remove the programming chip and return it to the original package.
7. Press one of the six PRE-SET buttons to reveal, in the DISPLAY WINDOW, the name of the program/drink.*
8. Carefully place the Blending Station motor back into the hole in the counter.

NOTE: If for any reason the programmed times are incorrect, they can be reset to the original factory settings following the instructions below.

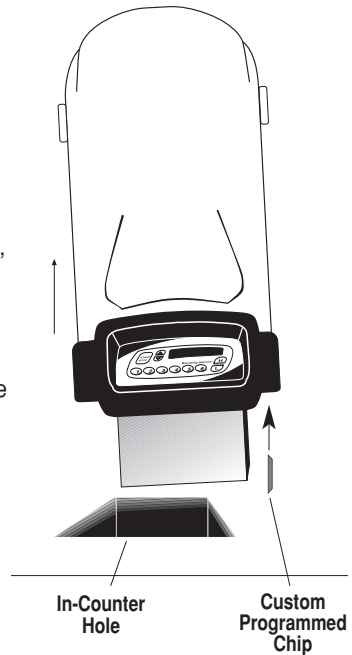

Resetting the PRE-SET buttons to the original factory settings



WARNING: Please read all steps before reprogramming. Reverting your PRE-SET PROGRAM buttons to the original factory setting, will erase any programming installed with a custom program chip.

1. Enter the OWNER CONTROLS (press the Vita-Mix Logo) 'Mode' will appear in the display window. Press the PRE-SET buttons 1 and 6 then the display window will say 'Count Temp Total'.
2. Press the Vita-Mix Logo two more times to reveal the instructions on resetting the PRE-SET buttons.
3. Press and hold the #4 button until the DISPLAY WINDOW reads 'Restoring Please Wait'. The PRE-SET buttons are now reset to the original factory settings.

**Your machines PRE-SET PROGRAM buttons function and times may be different then described in the owners manual due to your machine being custom programmed.*

Lid Assembly

Two-part Lid

48 oz. (1.4 liter) polycarbonate container

The two part lid is easy to clean and easy to put on, take off & seal.

- To remove fully latched lid, squeeze tabs together on both sides of the container, pull upward and off.
- Twist the center lid plug to fasten or remove.

NOTE: To make new lids easier to insert and remove, rub a light coating of cooking oil around bottom where it seals. Place it in container for several minutes, remove and lightly wipe oil off lid.

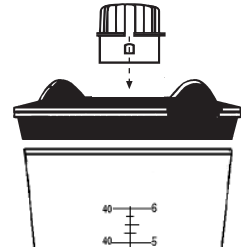

Figure A

Two-part Lid

64 oz. (2.0 liter) polycarbonate container

The two part lid is easy to clean and easy to put on and take off.

(Note: Brand new lids are a little stiff. This is temporary.)

- The lid has a continuous rim which latches inside the container tabs. Push one side of the rim under one tab, and with the heel of your hands push down, over the opposite tab, to snap lid into position.
- To remove lid, place hands around the lid, pressing thumbs above one of the container tabs. Push in and lift off.
- Twist the center lid plug to fasten or remove.

To secure lid plug, rotate it so one tab locks between the stops on top of rubber lid.

Press in above container tab to remove lid.

Rim

Container Tab

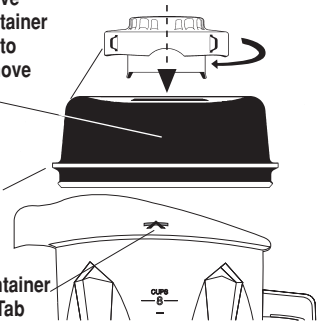

Figure B

Always latch lid when processing hot liquids.

One Piece Lid (optional)

64 oz. (2.0 liter) polycarbonate container (Figure C)

48 oz. (1.4 liter) polycarbonate container (Figure D)

The one piece lid is easy to clean and easy to put on and take off.

(Note: Brand new lids are a little stiff. This is temporary.)

- Follow the instructions above for placing the lid on the container and removing it from the container.
- 48 oz. / 1.4 liter lid does not latch.
- Add ingredients through port on top.

CAUTION: Do not use non-latching lid when processing hot ingredients.



Figure C



Figure D

Cover with Removable Hinge Design

Cover Door:

1. The Cover Door can be removed by opening it until the door is horizontal. Then, gently spread the sides of the door over the round hinges and remove.
2. To reinstall the Cover Door, gently spread the sides of the door and place the door hinge cutouts over the round hinges. (Figure E)

Back Cover:

1. To remove the Back Cover from the Blending Station:
 - a. First remove the Cover Door from the unit, as described above.
 - b. Remove the two (2) Back Cover mounting screws located on the rear of the machine. (Figure F)
 - c. From the rear of the machine, firmly push the bottom of the cover forward (towards the control panel), keeping the bottom edge of the cover against the motor base. **DO NOT tilt or strike the cover during removal.**
 - d. Slide forward until the side latches on the front of the cover are released from the motor base. **DO NOT strike the cover to “pop” the side latches from their tracks. Doing so will cause damage. The cover must only be removed by sliding it forward (towards the Control Panel).**
2. To replace the Back Cover on to the Blending Station:
 - a. Place the Back Cover on the motor base approximately one (1) inch (2.54 cm) forward of its normal position.
 - b. Slide the cover towards the back of the machine (away from the Control Panel). **Make sure the side latches slide into their tracks.**
 - c. Push until back of cover is seated against the Motor Base. **Make sure the Back Cover is fully seated in the back and the side latches are in their grooves before inserting and tightening the mounting screws.**
 - d. Replace and firmly tighten the two (2) Back Cover mounting screws. (Figure F) **DO NOT overtighten. DO NOT use the mounting screws to pull the Back Cover into position. Doing so will cause damage.**

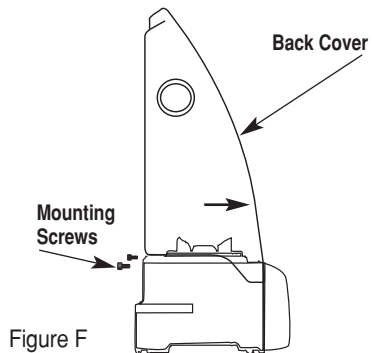
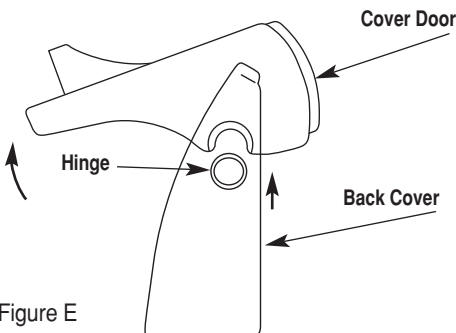

In-Counter Installation

Preparing the counter area:

- Before cutting holes, make sure that there is adequate clearance under the counter for the motor. The motor will extend about 5-2/3" (14.4 cm) below the counter but it is best to allow at least 10" (25.5 cm) from the under-counter to shelves or any other equipment under the counter. Also, when using the removable cover design, the back of the hole must be at least 6" (15.2 cm) from any wall to allow for cover door clearance.
- An extra 6.5" (16.5 cm) of open space, above the top of the cover will be needed for placement and removal of the In-Counter machine and for custom programming the SIX PRE-SET Buttons.
- If installing unit into a closed cabinet, use a 4" dia. (10.1 cm) flexible vinyl duct (dryer hose) to vent exhaust. Attach the vinyl duct to the bottom of your In-Counter Touch & Go® Blending Station® by forcing the end of the hose over the exhaust baffle of the unit. Run the vinyl duct out of the cabinet for proper ventilation. Do not vent hose into a wall, ceiling, or a concealed space of a building. Multiple units should not vent to a common manifold unit but to separate places. If running your Blending Station causes a suction on your cabinet door, place a spacer in the door frame to allow proper intake of air.



Do not use hose clamps or equivalent to attach exhaust hose on machine.

- When cutting holes for placement of multiple In-Counter units, position the edge of the machines at least 12" (30.48 cm) apart to ensure quick cleaning and proper venting between machines.
- In-Counter installation for a 120 VAC unit also requires you to have at least one 20 amp outlet per machine under the counter, available within six feet of the Touch & Go Blending Station. 220 VAC and 100 VAC units require a dedicated line. Consult an electrician for proper electrical needs.
- The In-Counter Blending Station also requires a gasket (provided in the machine's original package) to be placed between the machine and the counter. See page 12 for instructions.



DO NOT strike the blender when removing from the counter.

Electrical requirements:

- 120 VAC • 50/60 Hz. • 11.5 amps
- All Touch & Go Blending Stations are built using a U.S. 3 prong grounded cord and require a 20 amp outlet.
- 220/240 VAC • 50/60 Hz. • 1073-1176 Watts
- 100 VAC • 50/60 Hz. • 900 Watts

Blending Station dimensions:

- 17-1/2" (44.45 cm) high with lid closed
- 21-1/2" (54.7 cm) high with lid open
- Case depth: 12-3/4" (32.39 cm) with handle
- Case width: 9-1/2" (24.13 cm)
- Depth below counter: 5-2/3" (14.4 cm)
- Recommended distance between machines: 12" (30.48 cm) from the edge of each machine or as far apart as possible.

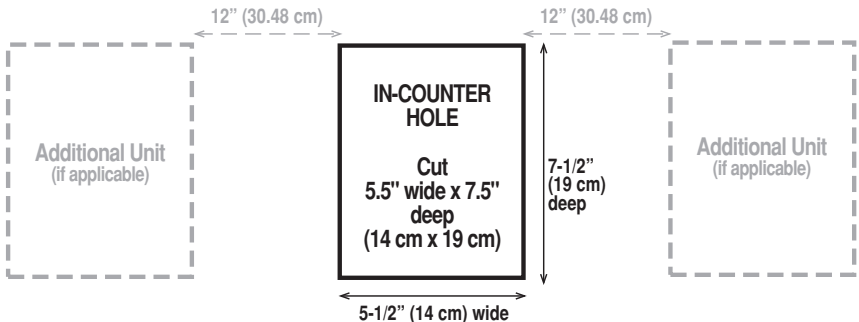
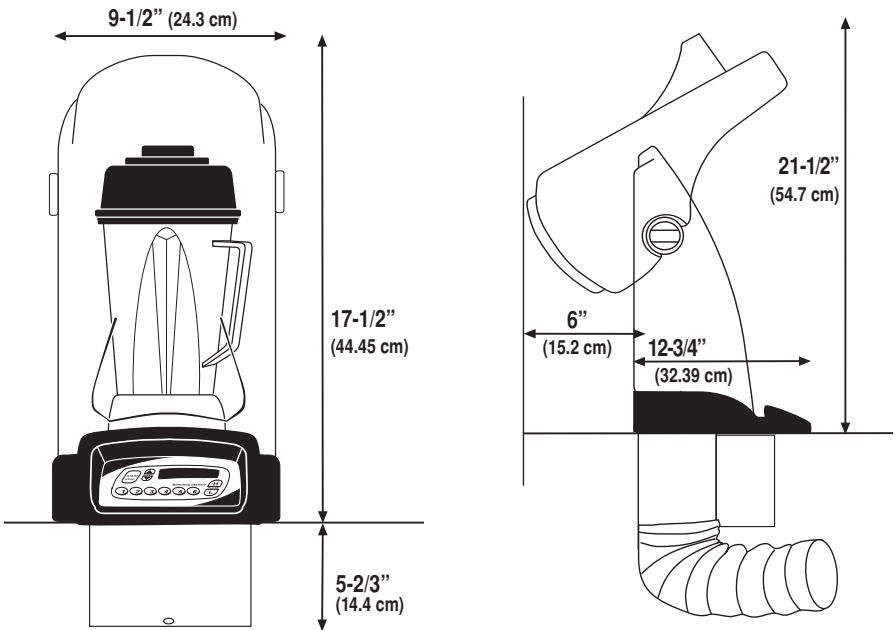

In-Counter Gasket

Gasket Installation Instructions:

1. Follow the instructions on page 10 on preparing the counter area for the installation of your In-Counter Touch & Go® Blending Station®. Also, use the Template Sheet (provided in your machine's original package) to assist you in the placement and ventilation of your machine.
2. Lay the blender on its back with the motor pointing toward you. Allow 1-2 in. (2.54 -5.08 cm) of the motor base to hang over the edge of the counter top to facilitate easy fitting of the gasket.
3. Slide the power cord through the gasket, with the groove of the gasket pointing toward the machine base.
4. Starting at one corner of the motor base, press the gasket onto the motor base, so that the groove in the gasket seats itself onto the stepped bottom edge of the motor base.
5. Working around the bottom edge of the motor base, press the gasket onto the motor base until the entire perimeter of the gasket is firmly attached to the motor base.
6. Carefully place the blender into the hole in the counter.
7. Be sure that the gasket is properly seated on the motor base and against the counter top.
8. Do not secure the machine to the counter with bonding materials.



This gasket was designed to protect your machine from water damage and to reduce noise. Failure to properly install this gasket could result in moisture damage.

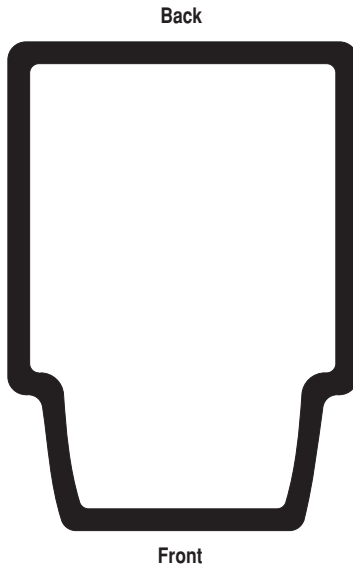

Blending Tips

1. If your recipe freezes up, try reducing the amount of ice. Compared to other blenders, you do not need as much ice to make an equally frozen drink in a Touch & Go™ Blending Station®.
2. Place liquids and soft foods in your container first. Hard items and ice should be placed last.
3. Whole, hard or frozen ingredients should be small. Solid frozen fruit is extremely difficult to blend. For best results use semi-frozen fruit. Using same size batches of semi-frozen fruit and ice will keep your drinks consistent. If you notice chunks, re-evaluate the batch size.
4. When creating recipes, always allow for enough liquid to ease the blending process. For recipes with minimal liquid, use the Speed Control buttons to run the machine on its lowest settings until it is processing smoothly. Finish blending by using one of the Pre-Set Programs that best matches the drinks viscosity.
5. When overheating occurs, review your techniques and instructions. The motor may be getting hot when your recipes are too thick. Consider adding more liquid and consult Vita-Mix, or your Vita-Mix distributor, for further assistance.

Maintenance Tips:

- Never bang the container against a surface to loosen the ingredients. Remove the container from the base and use a rubber spatula to remove thick mixtures from the bottom of your container.
- **Never shake or rattle a container in use while seated on the motor base.**
- **Never remove the container before the machine has come to a complete stop.**
- **Never start the motor before the container is in place.**



The instructions appearing in this Owner's Manual cannot cover every possible condition and situation that may occur. Common sense and caution must be practiced when operating and maintaining any appliance.

Instructions

How to operate your Blending Station® using the six Pre-Set Programmed Buttons.

The following is the basic factory settings of the six PRE-SET buttons (your machine's PRE-SET buttons may differ due to program revisions or if your Blending Station was programmed specifically for your business).*

- **Button 1:** (:15) *Blends thin drinks with just juice and ice.* This program will quickly ramp to a high blending speed for 15 seconds.
 - **Button 2:** (:20) *Blends light coffee drinks.* Button 2 will ramp the blending speed to medium for six seconds and ramp up to high for 14 seconds.
 - **Button 3:** (:32) *Creates a specialty drink with a thick viscosity.* Button 3 runs at a medium speed, ramps down, then increases to high speed, and finishes the drink at medium speed.
 - **Button 4:** (:34) *This cycle is good for ice cream and regular coffee drinks that need a little longer blending.* Button 4 increases to medium speed for four seconds then ramps up slowly to a high speed for 14 seconds.
 - **Button 5:** (1:35) *Blend a regular smoothie for an extended cycle.* Button 5 runs for 45 seconds on a medium speed and then increases in speed and runs on high for 50 seconds.
 - **Button 6:** (:25) *Blend thick frozen fruits & hard ingredients for a thick but consistent smoothie.* Button 6 gradually ramps up the blending speed, maintaining intermediate speeds and gradually progressing until it reaches full speed.
1. Place liquids and soft foods in the machines container first, solid items and ice last. Prepare food by cutting or breaking into 1-3 in. (2.54 -7.62 cm) pieces. Frozen fruit, especially, should be as small as practical. Thawed or partially thawed fruit is recommended. We recommend PROGRAMMED button #5 or #6 for heavy-duty blending.
 2. Set the container on the motor base by aligning it over the centering pad anchored to the base. **(Motor must be completely stopped before positioning container).** Containers are not to be used for hard, dry materials. Avoid running the Blending Station with container empty.
 3. Always use a lid when blending. If blending hot ingredients, the lid must be securely in place.
 4. Select desired programmed setting by pressing any of the Pre-Set Buttons one through six. The machine will begin immediately to cycle through the selected program, and turn off when the program is complete. Each button has a different pre-selected combination of speed and length for blending.
- NOTE:** If you detect a change in the sound of the machine or if a hard or foreign object comes into contact with the blades, do not serve the drink. Inspect your blade assembly for loose, knicked or missing parts. If parts are loose, missing or knicked replace with a new blade assembly. (See page 22).

**Your machines PRE-SET PROGRAM buttons function and times may be different then described in the owners manual due to your machine being custom programmed.*

5. Once one of the six PRE-SET PROGRAM buttons is pushed the machine will start and stop automatically. By pressing another PRE-SET BUTTON or the START/STOP button, the machine will stop the blending cycle.
6. During any of the blending cycles, by pressing the PULSE H button the speed of the blending can increase up to 100% of the motor speed. By pressing the PULSE L button during a blending cycle the speed of the motor can be decreased down to 7%. Once released the motor speed will revert back to the blending cycle of the PRE-SET PROGRAM.

(NOTE: Use the SPEED CONTROL buttons to set the speed of the PULSE buttons. For example, when the H or L PULSE button is pressed and held, by simultaneously pressing and holding the ▲ or ▼ SPEED CONTROL button the motor speed will increase or decrease in 1% increments. When the SPEED CONTROL button is released, the PULSE button will remain set at the selected speed until altered with the SPEED CONTROL buttons.)

7. When the cycle is complete the blender stops, **wait until blade comes to a complete stop before removing the lid and/or container from the motor base.**
8. Remove the container, pour, garnish and serve the drink.

How to operate your Blending Station® using the Start/Stop and Speed Control button.

Although using the PRE-SET PROGRAMMED buttons is highly recommended for the best drink, occasionally a drink may need special attention. By using the START/STOP button and the SPEED CONTROL button you can manually control the speed of the Blending Station.

1. Follow steps one through three of 'How To Operate Your Blending Station Using The Six Pre-Set Programmed Buttons' section on page 14.
2. The speed of the motor can be changed with:
 - the motor off.
 - Press the ▲ or ▼ buttons until the desired speed percentage is displayed. 100% is the highest setting and 7% is the lowest setting.
 - When the START/STOP button is pressed the motor will ramp quickly to that speed
 - Blending can be stopped by pressing the START/STOP button at any time.
 - the motor on.
 - With the container in place press the START/STOP button. The machine will begin blending.
 - While the machine is running Press the ▲ or ▼ buttons until the desired speed percentage is displayed. 100% is the highest setting and 7% is the lowest setting.
 - Release the SPEED CONTROL button and the motor will now run at the desired speed.
 - The blending can be stopped by pressing the START/STOP button.
3. The PULSE buttons can also be used to quickly increase the motor speed or decrease the motor speed. (See HIGH/LOW PULSE button description on page 5.)
4. When done blending press the START/STOP button to stop the motor.

Wait until blade comes to a complete stop before removing the lid and/or container from the motor base.
5. Remove the container from the motor base and serve the drink.

NOTE: On all units the built-in thermal sensor keeps track of how hot the motor gets and will warn the user and eventually shut down the motor if the motor is overheating. When overheated the display will instruct the user to remove the container and run the machine until cool. This takes about a minute. See page 21, "Cooling the motor," for complete instructions. See page 13 for Blending Tips to avoid overheating the motor.

Parts List

Item#	Part
#752	64 oz. (2.0 liter) - Container without lid assembly or blade assembly
#755	64 oz. (2.0 liter) - Lid plug
#756	64 oz. (2.0 liter) - Container, blade assembly & lid assembly
#1191	64 oz. (2.0 liter) - 2-piece lid assembly
#1192	64 oz. (2.0 liter) - Lid only (no plug)
#15595	64 oz. (2.0 liter) - 1-piece latching rubber lid
#1159	48 oz. (1.4 liter) - lid plug
#15502	48 oz. (1.4 liter) - Container only
#15506	48 oz. (1.4 liter) - Container, blade & lid assembly
#15507	48 oz. (1.4 liter) - 2-piece lid assembly
#18002	Back cover and cover door with removable hinge design
#18003	Cover door with removable hinge design
#18004	Back cover with removable hinge design
#890	Sound reducing centering pad
#891	Drive socket
#836	Heavy-duty retainer nut
#1151	Agitator assembly (ice blades)
#15596	Retainer nut wrench
#18005	Metal Mounting Screws - (2)
#15603	In-Counter Gasket

NOTE: Blade Assembly, Drive Socket and Retainer Nut are compatible on either the polycarbonate or stainless steel containers. Other than the Drive Socket, Blade Assembly and Retainer Nut, this unit is not user serviceable.

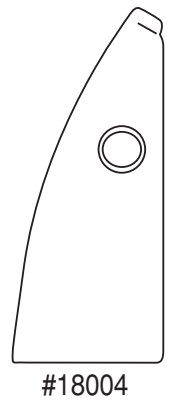
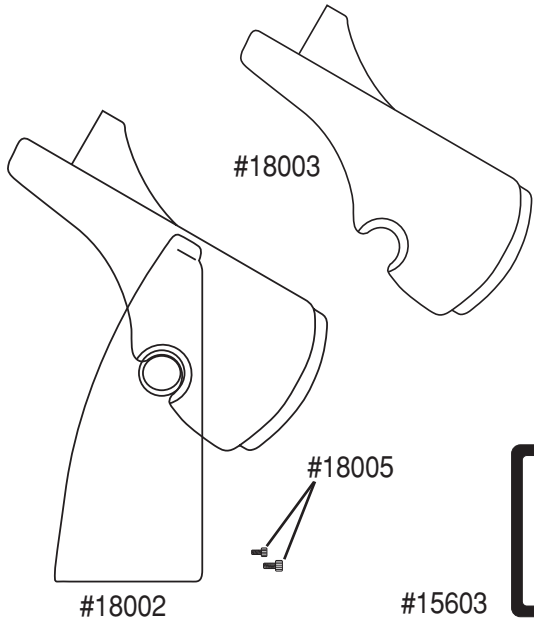
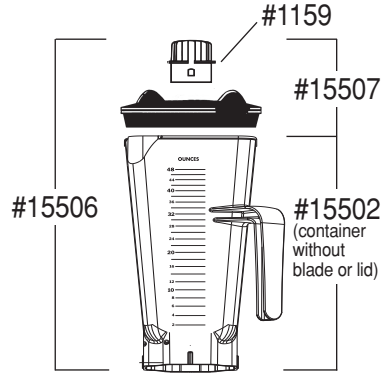
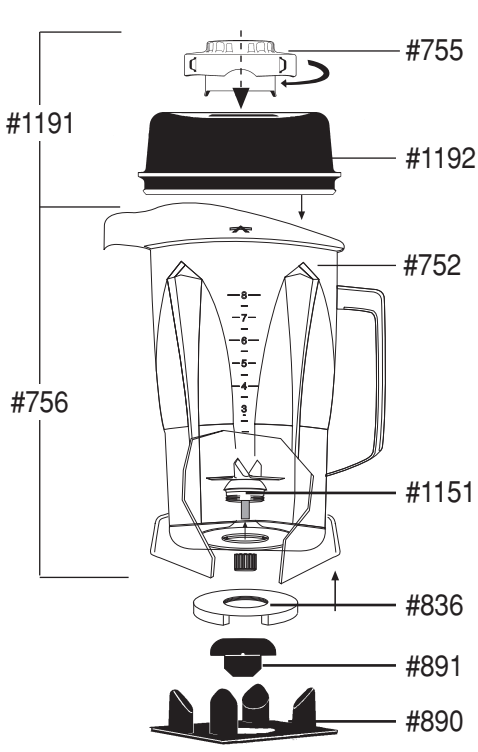

Care and Cleaning

Care Note

To ensure that you get the longest possible life from your Vita-Mix product, we recommend the following products, when used as directed by the supplier:

Cleaning Product

Solid Supra, Solid Power,
Guardian Acclaim, Solid Guardian Plus,
Solid Super Impact, Solid Insure
Diverpak
Eclipse H2
Liqui-Safe L7
Acclean
Poly-Brite

Glow MB-1
Lustre NC-25
Lustre Plus

PSRA 41-D, PSRA 41-E
Liqui-Ware 1, Liqui-Ware MC
D-Flex, Sur-Met

Rinse Aids

Solid Rinse Dry
Solid Brilliance
Jet Dry, Rinse Dry

Destainer
NuWare

Supplier

Ecolab, Inc., St. Paul, MN
Tel: (800) 352-5326
www.ecolab.com
Diversey, Livonia, MI
(800) 521-8140

Klenzade Products
Division of Ecolab
St. Paul, MN
(612) 293-2165
Wesmar Company, Inc.
Seattle, WA
(206)783-5344
www.wesmar.com
Anderson Chemical Co.
Litchfield, MN
(800) 366-2477
www.andersonchemical.com

Supplier

Ecolab, Inc., St. Paul, MN
(800) 352-8140
www.ecolab.com

Supplier

Diversey, Livonia, MI
(800) 521-8140



DO NOT use abrasive cleaning agents or concentrated bleach when cleaning.

CARE NOTE: Do not let mixtures, liquids and food products dry within the container. Rinse throughout use. Drying product may lock around the blade and weaken/tear the bearings seal when restarted. Do not place containers in the freezer. Extremely low temperature combined with hot ingredients and/or the immediate rapid action of the blade may crack the container.

Motor Base

1. Unplug the power cord.
2. Wash outside surface with a damp soft cloth or sponge, which has been rinsed in a mild solution of liquid dish soap (Ivory Liquid® or equivalent) in warm water. **NEVER IMMERSE MOTOR BASE IN WATER OR OTHER LIQUID. NEVER POUR WATER OR ANY OTHER LIQUID ON THE MOTOR BASE.**
3. Polish with a soft cloth.

Control Panel

Gently wash the front panel with a soft cloth and a low pH balanced soap, being careful not to scratch the Display Window.

NOTE: Be sure to wring excess water out of cloth or sponge when cleaning around the controls, drive socket or any electrical part.

Lid

Separate the lid and plug, then wash in warm soapy water. Rinse clean under running water and dry. Reassemble before use. (See pages 8 & 9).

Cover Door

The cover can be removed (See page 9) and cleaned by placing under running water and washed with a soft cloth. Wipe dry and replace back on the base. **NOTE: DO NOT wash cover door in dishwasher.**

In-Counter Gasket

Carefully remove the gasket from under the blender. Wash the gasket in warm, soapy water, rinse clean and let dry. Reassemble before use (See page 12). **Make sure the gasket is seated properly against the blender and the counter.**

Container

1. To clean: Fill pitcher 1/4 full with warm (110°F / 43°C) water and add a couple drops of dish soap. Return container to motor base and firmly position the two part lid. Run machine for 30 seconds. Empty container. Repeat this step.

NOTE: For maximum container life DO NOT wash in dishwasher.

2. Fill pitcher 3/4 full with warm (110°F / 43°F) water (do not add soap). Return container to motor base and firmly position the two part lid. Run machine for 30 seconds. Empty container.
3. If any solid residue remains, remove the blade agitator assembly (see page 17) and wash all container parts in warm soapy water. Rinse and drain. Reassemble before next step.

Do Not soak the blade agitator assembly.

4. To sanitize: If all solid residue is gone after step 2 or after completion of step 3, fill container 3/4 full with a sanitizing solution mix.** Return container to motor base and firmly position the two part lid. Run machine on HIGH for 30 seconds. Empty container.
5. Return container to motor base and run machine empty for an additional 5 seconds. Do not rinse after sanitizing.

**Recommended sanitizing solution: 1-1/2 teaspoons Clorox® or other institutional bleach in 2 quarts (1.9 liter) water.



Important: Check your blades daily for loose, knicked or missing parts. If you find something is loose, knicked or missing, replace the blade assembly before use. Do not tighten hex-headed screw (on top of blade assembly). If loose, replace blade assembly.

Troubleshooting

Top nine problems you can fix on your own:

1. Problem:

- Display Panel reads

THERMAL SENSOR FAILURE

Solution #1:

Turn the machine off and on again to reset the programming

Solution #2:

Call Vita-Mix Customer Service.

2. Problem:

- Loud noise from blender container blade area
- Container blades do not spin
- Increased vibration
- Leaking from bottom of container

Solution #1:

Broken or worn Drive Socket. Replace (Item #891). Instructions are included with part.

Solution #2:

Check blade assembly for loose, damaged or knicked components and replace.

Solution #3:

Tighten retainer nut on the bottom of the container

3. Problem:

- Loud grinding noise from the blender motor

Solution #1:

Due to some faulty motor bearings your machine may need to be repaired. Call Vita-Mix Customer Service.

4. Problem:

- Machine will not run
- Display screen does not say 'READY'

Solution #1:

Double-check to make sure power cord is firmly in power outlet.

Solution #2:

Check to make sure the ON/OFF switch is in the ON position.

Solution #3:

Turn the ON/OFF switch to off, then on, to reboot the electronics.

5. Problem:

- Machine starts then shuts off

Solution #1:

Check to make sure there is power to the machine.

Solution #2:

Call Vita-Mix Customer Service.

6. Problem:

- Display Panel reads

MOTOR LOCKED PROGRAM
TERMINATED

Solution #1:

Let the machine cool down for an hour then restart.

Solution #2:

Call Vita-Mix Customer Service if the machine does not work after sitting at room temperature for 24 hours

7. Problem:

- Machine is running irregular
- Display panel reads garbage
- “NO PROGRAM” is displayed when a button is pushed
- Button pressed starts the wrong program
- Machine starts by itself
- a specific program button is defective
- machine was turned off for a day, week or month and turned on, there was no power
- machine did not work right out of the box
- machine works but no information displayed on screen
- program buttons run the blender on the same speed

Solution #1:

Turn the machine off and on again to reset the programming.

Solution #2

Reset the machine to its original factory settings. (Follow the instructions on page 7)

Solution #3:

Try plugging the machine into a new outlet.

Solution #4:

Call Vita-Mix Customer Service.

8. Problem:

- Display panel reads



CORRUPT DATA

Solution #1:

A new programming chip is needed. Call Vita-Mix Customer Service.

9. Problem:

- Machine stops in the middle of its blend cycle and resets; display panel reads “VITA-MIX GENERAL PROGRAM” then “READY”

Solution #1:

Plug the machine into its own power supply.

Solution #2:

Make sure the machine is not running on a long extension cord.

Cooling the motor:

If the machine has overheated:



MOTOR HAS OVERHEATED REMOVE...
HOT SHUTDOWN

- The motor will stop and the message “MOTOR HAS OVERHEATED REMOVE THE CONTAINER, THEN PRESS START”, will scroll across the display window, while the words “HOT SHUTDOWN” will remain in the display window alerting you of the problem.
- The machine will not run until the container is removed and the motor has cooled. Remove the container, shut the cover door and press the START/STOP button, and run the machine for two minutes.
- When the motor is cool “READY” will appear in the display window.



READY

If you cannot fix your machine with these suggestions, technical help is available by calling 800-4DRINK4 (800-437-4654), 440-235-0214. Outside the United States and Canada contact your Vita-Mix distributor or contact Vita-Mix International at +1(440) 782-2450 or email international@vitamix.com for a local distributor or visit us at www.vitamix.com/foodservice.

***B**lade Agitator Assembly*

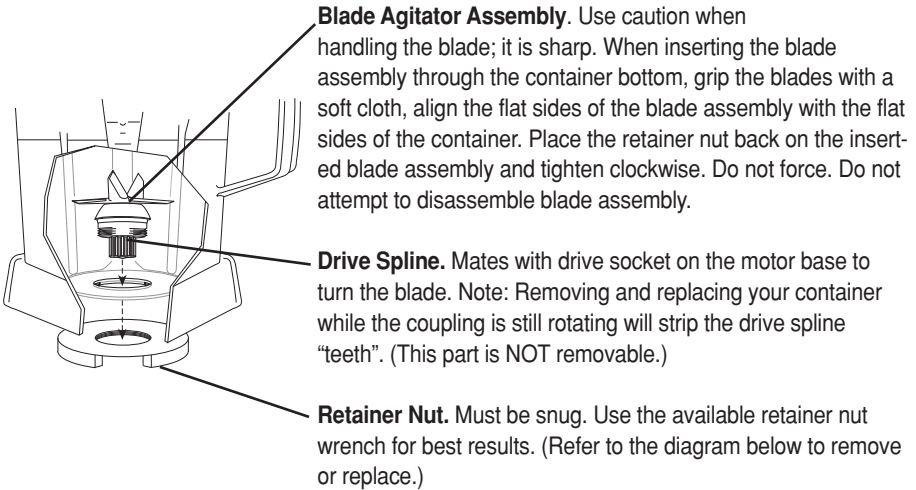

Never use a blade assembly with loose, damaged or knicked components.

Retainer Nut Removal

- The retainer nut is easily removed using the Retainer Nut Wrench. To order a Retainer Nut Wrench please call your Vita-Mix distributor and ask for Item #15596.
- To remove, turn the container upside. Using the Retainer Nut Wrench turn the wrench counterclockwise to loosen the nut. Once loosened, remove by hand.
- To replace, position retainer nut on top of blade assembly and hand tighten. Then, using the Retainer Nut Wrench, tighten clockwise until it stops. If it is not tight enough, you will notice increased container noise.

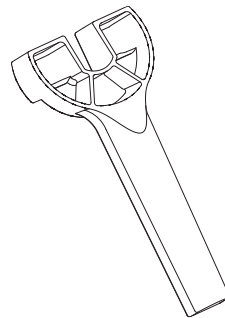

Retainer Nut Wrench

Warranty

Limited Warranty

Vita-Mix® Corporation warrants your Commercial Blending Station® to be free from defects in materials and workmanship for a period of three years from the date of purchase when used in accordance with the accompanying instruction booklet.

Provisions of this limited warranty are void if your Touch & Go™ Blending Station® has been subjected to obvious abuse, negligence, accident, alteration, or failure to follow operating instructions, or product exposure to abnormal or extreme conditions. Cosmetic changes such as discoloration of parts of the product in the hands of the user or the effects of the use of abrasive cleaners will not be warranted or considered defects. The cleaning or removal of food products along with any damage caused by allowing them to build-up is not covered by this limited warranty. Improper installation of the in-counter model is not covered by this warranty. Also this warranty is void if the Blending Station is put into a sound reduction chamber or otherwise prevented from receiving proper cooling. In the event your Vita-Mix appliance needs service or repair covered by the terms of this warranty, please call the Vita-Mix Corporation for shipping instructions.

The Blending Station must be sent in original or sufficient packaging. This limited warranty is in lieu of any other warranty expressed or implied. No representative or any other person is authorized to make any other warranty or to assume any liability not strictly in accordance with the foregoing. This limited warranty gives you specific legal rights which may vary from state to state. Proof-of-purchase may be required to prove date of purchase.

Outside the Continental United States and Canada other warranties will apply. (Call or check with your local Vita-Mix distributor for details.) In case of shipping damage, notify the shipper or carrier immediately.

Service Contract

PLEASE NOTE: The Service Contract outlined in the following paragraph applies only to customers in the United States and Canada. Customers in all other countries should contact their local Vita-Mix distributor for service details.

This Blending Station® includes a 1-Year Service Contract effective from date of purchase. In the event your machine should need parts or repairs, covered under this Service Contract, call Vita-Mix® customer service immediately for instructions. Proof of date of purchase may be required. This does not cover abuse, misuse, tampering, improper installation or extreme conditions.

The Vita-Mix Service Contract includes the following:

1. Only one extra drive socket - to facilitate simple repairs and prevent down time is included and packaged with each machine.
2. Additional drivers and tamper, unless defective and cosmetic changes, such as discoloration of parts are not covered. NOTE: to determine if you have a defective part, please order a replacement part through Vita-Mix Customer Service, and when the new part arrives, return the old part in the same packaging. Vita-Mix will inspect the returned part and, if

CONTINUED FROM PAGE 23

defective, issue a refund for the price of the new part. A part will be considered defective if no abuse or neglect was involved with its break. Non-defective parts sent to Vita-Mix for inspection will not be returned if deemed unusable. Service Contract covers functionality of the machine but not abuse or lack of recommended maintenance.

3. In Continental USA, sender pays freight one way to Vita-Mix Corporation. Vita-Mix Corporation pays UPS ground freight charges to return machine to sender. Sender pays costs for special shipping requests. Outside Continental USA, other service contracts may apply.

NOTE: Limited Warranty and Service Contract are honored directly through the Vita-Mix Corporation, Cleveland, Ohio USA. Non-warranty repairs can be performed by any CFESA service center. Call Vita-Mix at (800) 4DRINK4 (800-437-4654) or 440-235-0214. Before returning this product for any reason, including repair, please, first contact our Customer Service Department at: (800) 4DRINK4 (800-437-4654), or 440-235-0214 to receive a "Return Authorization Number". Outside the USA, contact your Vita-Mix Distributor.

Blending Station® Specifications

Blending Station On-Counter:

Height of unit closed: 22" (54.56 cm)
Shipping weight: 21 lbs. (9.534 kg)
Dimensions 22" High x 9-1/4" Wide x 10-1/2" Deep
(54.56 cm x 23.45 cm x 25.86 cm)

Blending Station In-Counter:

Height of unit above counter: 17-1/2" (44.45 cm) closed
Depth of unit below counter: 5-2/3" (13.3 cm)
Shipping Weight: 18 lbs. (8.172 kg)
Dimensions: 24" total Height x 9" Width x 12-1/2" Depth
(45.03 cm x 22.65 cm x 31.28 cm)

Power Requirements:

Volts: 120 VAC	Volts 220/240 VAC	Volts: 100 VAC (Japan)
Amps: 11.5	Watts: 1073-1178	Watts: 900
Hz: 50/60	Hz: 50/60	Hz: 50/60



VITA-MIX® CORPORATION **Foodservice Division**

8615 Usher Road, Cleveland, Ohio 44138-2103 USA
www.vitamix.com/foodservice

©2004 Vita-Mix Corporation. No part of this publication may be reproduced or transmitted in any form or by any means, electronic or mechanical, including photocopy, recording or any information storage and retrieval system without the written permission of the Vita-Mix Corporation.