

SERVICE MANUAL

(DOMESTIC AND INTERNATIONAL)

IMPINGER CONVEYOR OVENS

MODEL 1400 SERIES ADVANTAGE



Lincoln Foodservice Products, LLC
1111 North Hadley Road
Fort Wayne, Indiana 46804
United States of America

Phone : (800) 374-3004

U.S. Fax: (888) 790-8193 • Int'l Fax: (260) 436-0735

Technical Service Hot Line
(800) 678-9511

www.lincolnfp.com

TABLE OF CONTENTS

TABLE OF CONTENTS	2
SEQUENCE OF OPERATION.....	4
MODEL 1450 / 120 VAC / 60 HZ / NATURAL GAS	4
MODEL 1451 / 120 VAC / 60 HZ / LP GAS.....	4
MODEL 1480 / 120 VAC / 60 HZ / TOWN GAS	4
SEQUENCE OF OPERATIONS	4
MODEL 1452 120/208 VAC 3 PHASE 60 HZ.....	4
MODEL 1453 120/240 VAC 3 PHASE 60 HZ.....	4
SEQUENCE OF OPERATIONS	5
MODEL 1454 / 380/220 VAC / 50 HZ / 3 PHASE	5
MODEL 1455 / 415/240 VAC / 50 HZ / 3 PHASE	5
SEQUENCE OF OPERATIONS	6
MODEL 1456 / 220-240 VAC / 50 HZ / NATURAL GAS	6
MODEL 1457 / 220-240 VAC / 50 HZ / L.P. GAS	6
MODEL 1474 / 220-240 VAC / 50 HZ / NATURAL GAS	6
MODEL 1475 / 220-240 VAC / 50 HZ / L.P. GAS	6
MODEL 1476 / 220-240 VAC / 50 HZ / TOWN GAS.....	6
SCHEMATIC 1450 / 1451 / 1480	7
SCHEMATIC 1452 / 1453	8
SCHEMATIC 1454 / 1455	9
SCHEMATIC 1456 / 1457	10
SCHEMATIC 1474 / 1475 / 1476.....	11
TROUBLESHOOTING GUIDE.....	12
GAS OVENS.....	12
TROUBLESHOOTING GUIDE.....	19
ELECTRIC OVENS.....	19
REMOVAL INSTALLATION & ADJUSTMENTS.....	22
CONVEYOR CONTROL BOARD ASSEMBLY - REPLACEMENT	28
GENERAL – 1450 SERIES.....	30
GENERAL - 1450 SERIES BLOW-UP	31
CONTROL BOX – 1450, 1451, 1480.....	32
CONTROL BOX – 1450, 1451, 1480 BLOW-UP	33
CONTROL BOX – 1452, 1453.....	34
CONTROL BOX – 1452, 1453 BLOW-UP	35
CONTROL BOX – 1454, 1455.....	36
CONTROL BOX – 1454, 1455 BLOW-UP	37
CONTROL BOX – 1456, 1457, 1474, 1475, 1476.....	38
CONTROL BOX – 1456, 1457, 1474, 1475, 1476 BLOW-UP	39
OVEN BACK, GAS – ELECTRIC.....	40
OVEN BACK, GAS – ELECTRIC BLOW-UP.....	41
CONVEYOR – 1450 SERIES	42
CONVEYOR 1450 SERIES BLOW-UP	43

SEQUENCE OF OPERATION

MODEL 1450 / 120 VAC / 60 HZ / NATURAL GAS
MODEL 1451 / 120 VAC / 60 HZ / LP GAS
MODEL 1480 / 120 VAC / 60 HZ / TOWN GAS

POWER SUPPLY	Electrical power is supplied to the oven by a three-conductor cordset. Voltage from the black conductor to white conductor is 120 VAC. The white conductor is neutral. The green conductor is ground.
CONTROL BOX	When the temperature in the control box reaches 120°F±3°
AUTO COOL DOWN	(48.9°C±1.7°C), the cooling fan thermostat will switch power to the control box-cooling fan. The thermostat will interrupt power to the fan when the control box temperature falls to 100°F±3°(37.0°C±1.7°C).
MAIN FAN CIRCUIT	Electrical power is permanently supplied to the normally open contacts of the double pole main fan relay, the cooling fan thermostat and the normally open switch. Closing the on/off switch energizes the coil of the relay through the 3A fuse. The normally open contacts now close, energizing the main fan motor through the 10A fuse, and the control box-cooling fan. Closing the on/off switch also supplies 120 VAC to the burner blower motor, the conveyor control board and to the normally open centrifugal switch of the main fan motor.
BURNER CIRCUIT	Closing the on/off switch supplies 120 VAC to the burner blower motor and the normally open centrifugal switch of the main fan motor. As the fan motor reaches approximately (900 RPM) the centrifugal switch closes supplying 120 VAC to the electronic temperature control board and the primary of the burner control transformer. The transformer secondary supplies 24 VAC through the normally open centrifugal switch (inside the burner blower motor, this switch closes at approximately 1600 RPM) to the burner control. The igniter circuit is now energized.
IGNITION CONTROL	When the burner control is supplied with 24 VAC, the pilot valve and spark igniter is energized. Ignition should now occur, after the pilot flame is proven, the main gas valve is energized.
TEMPERATURE CONTROL	When the centrifugal switch of the main fan motor closes, 120 VAC is applied to the temperature controller. The temperature dial is adjusted to the desired temperature. The thermocouple will provide varying millivolts to the temperature controller. The temperature controller supplies 120 VAC to the solenoid valve (and the yellow cycling lamp on the front panel) at intermittent intervals to maintain desired temperatures.
CONVEYOR DRIVE	Closing the on/off switch supplies 120 VAC to the conveyor control board. AC volts are converted to DC volts and are supplied to the conveyor motor at terminals A+ and A- Adjustment of the speed control potentiometer will change resistance at terminals P1 & P2, varying the DC voltage to the motor. The speed of the conveyor motor will increase or decrease as the DC voltage from the board increases or decreases respectively. NOTE: The conveyor control uses a sensor and magnet, mounted on the conveyor motor that senses the motor speed. Any change in motor load (± RPM) is detected by the sensor and the voltage to the motor is adjusted accordingly.

SEQUENCE OF OPERATIONS

MODEL 1452 120/208 VAC 3 PHASE 60 HZ
MODEL 1453 120/240 VAC 3 PHASE 60 HZ

POWER SUPPLY	Electrical power is to be supplied to the oven by a 5-conductor service. Black conductor is hot. Red conductor is hot. Orange conductor is hot. White conductor is dedicated neutral. Green conductor is ground.
CONTROL BOX AUTO COOL DOWN	When the temperature in the control box reaches 120°F ± 3°, (49°C ± 1.7°C), the cooling fan thermostat will switch power to the cooling fan. The thermostat will interrupt power to the cooling fan when the temperature falls to 100°F±3° (37°C ± 1.7°C).
MAIN FAN CIRCUIT	Electrical power is permanently supplied through 6, 50A fuses to the normally open contacts of the mercury contactors. Power is also supplied through 1, 10A fuse to the normally open contacts of the main fan relay, to the normally open cooling fan thermostat, and through a 3A fuse to the normally open single pole main fan switch. Closing the main fan switch supplies 120 VAC to the coil of the main fan relay. The coil of the relay is

	energized, the normally open contacts close, energizing the main fan motor and cooling fan. Closing the main fan switch also supplies power to the conveyor control and the centrifugal switch of the main fan motor.
HEAT CIRCUIT	Closing the on/off switch supplies 120 VAC to the normally open centrifugal switch (inside the main fan motor). As the motor reaches approximately (900 RPM) the centrifugal switch closes supplying 120 VAC through the normally closed oven cavity and control box hi-limit thermostats, to the electronic temperature control board
TEMPERATURE CONTROL	When the centrifugal switch (inside the main fan motor) closes, 120 VAC is applied to the temperature controller. The temperature dial is adjusted to the desired temperature. The thermocouple will provide varying millivolts to the temperature controller. The temperature controller supplies 120 VAC to the contactor coils at intermittent intervals (closing the contactors and supplying 208 or 240 VAC to the heating elements) to maintain desired temperature. The ready lamp is energized with the contactors.
CONVEYOR DRIVE	Closing the on/off switch supplies 120 VAC to the motor control board. AC volts are converted to DC volts and are supplied to the conveyor motor at terminals A+ and A-. Adjustment of the speed control potentiometer will change resistance at terminals P1 & P2 varying the DC voltage to the motor. The speed of the conveyor motor will increase or decrease as the DC voltage from the board increases or decreases respectively. NOTE: The conveyor control uses a sensor and magnet, mounted on the conveyor motor that senses the motor speed. Any change in motor load (\pm RPM) is detected by the sensor and the voltage to the motor is adjusted accordingly.

SEQUENCE OF OPERATIONS

MODEL 1454 / 380/220 VAC / 50 HZ / 3 PHASE
MODEL 1455 / 415/240 VAC / 50 HZ / 3 PHASE

POWER SUPPLY	Electrical power is to be supplied to the oven by a 5-conductor service. Black conductor is hot. Red conductor is hot. Orange conductor is hot. White conductor is dedicated neutral. Green conductor is ground
CONTROL BOX AUTO COOL DOWN	When the temperature in the control box reaches $120^{\circ}\text{F} \pm 3^{\circ}$, ($49^{\circ}\text{C} \pm 1.7^{\circ}\text{C}$), the cooling fan thermostat will switch power to the cooling fan. The thermostat will interrupt power to the cooling fan when the temperature falls to $100^{\circ}\text{F} \pm 3^{\circ}$ ($37^{\circ}\text{C} \pm 1.7^{\circ}\text{C}$).
MAIN FAN CIRCUIT	Electrical power is permanently supplied through three 50A fuses to the normally open contacts of the mercury contactor. Power is also supplied through 1, 10A fuse to the normally open contacts of the main fan relay, to the normally open cooling fan thermostat, through a 3A fuse to the normally open single pole main fan switch. Closing the main fan switch supplies 220/240 VAC to the primary of the control circuit step down transformer. (The transformer steps the voltage down to 120 VAC for the control circuit.) 120 VAC is supplied to the coil of the main fan relay. The coil of the relay is energized, the normally open contact close, energizing the main fan motor and cooling fan. Closing the main fan switch also supplies power to heat and conveyor control.
HEAT CIRCUIT	Upon closure of the on/off switch 120 VAC is supplied through the air pressure switch, through the normally closed oven cavity and control box hi-limit thermostats to the electronic temperature control.
TEMPERATURE CONTROL	When 120 VAC is supplied to the temperature controller and the temperature dial is adjusted to the desired temperature, the thermocouple will provide varying millivolts to the temperature controller. The temperature controller supplies 120 VAC to the contactor coil at intermittent intervals, (closing the contactor and supplying 220 or 240 VAC to the heating elements) to maintain desired temperature.
CONVEYOR DRIVE	Closing the on/off switch supplies 120 VAC to the conveyor control board. AC volts are converted to DC volts and are supplied to the conveyor motor at terminals A+ and A-. Adjustment of the speed control potentiometer will change resistance at terminals P1 & P2 varying the DC voltage to the motor. The speed of the conveyor motor will increase or decrease as the DC voltage from the board increases or decreases respectively. NOTE: The conveyor control uses a sensor and magnet, mounted on the conveyor motor that senses the motor speed. Any change in motor load (\pm RPM) is detected by the sensor and the voltage to the motor is adjusted accordingly.

SEQUENCE OF OPERATIONS

MODEL 1456 / 220-240 VAC / 50 HZ / NATURAL GAS
MODEL 1457 / 220-240 VAC / 50 HZ / L.P. GAS
MODEL 1474 / 220-240 VAC / 50 HZ / NATURAL GAS
MODEL 1475 / 220-240 VAC / 50 HZ / L.P. GAS
MODEL 1476 / 220-240 VAC / 50 HZ / TOWN GAS

POWER SUPPLY	Electrical power is to be supplied to the oven by a three-conductor service. Brown conductor is hot. Blue conductor is neutral. Green conductor is ground.
CONTROL BOX AUTO COOL DOWN	When the temperature in the control box reaches 120°F ± 3° (48.9°C ± 1.7°C), the cooling fan thermostat will switch power to the control box cooling fan. The thermostat will interrupt power to the cooling fan when the control box temperature falls to 100°F ± 3° (37.0°C ± 1.7° C).
MAIN FAN CIRCUIT	Electrical power is permanently supplied to the normally open contacts of the double pole main fan relay, the cooling fan thermostat and, through a 3A fuse to the normally open double pole main fan switch. Closing the oven fan switch supplies line voltage to the primary of the control circuit step down transformer. The transformer steps the voltage down to 120 VAC for the control circuit. 120 VAC is supplied to the coil of the double pole main fan relay. The coil of the relay is energized. The normally open contacts now close, energizing the main fan motor through one 10A fuse, and the cooling fan motor.
BURNER CIRCUIT	Closing the oven fan switch supplies line voltage through the main fan air pressure switch, through the gas pressure proving switch, through the normally closed Hi-Limit Thermostat, to the ignition control. The combustion motor is now energized. The normally open combustion air switch closes upon sensing air. After a pre-purge period of between 30 and 60 seconds, the spark generator and the main gas valve are energized. Ignition should now occur, after proving, gas control relay is energized.
TEMPERATURE CONTROL	Closing the oven power switch supplies 120 VAC (through the step-down transformer) to the temperature control board. The temperature dial is adjusted to desired temperature. The thermocouple will provide varying millivolts to the temperature controller. The temperature controller supplies 120 VAC through contact of gas control relay to the solenoid valve at intervals to maintain desired temperature. The ready lamp is energized with the solenoid valve (an electronic flame monitor proves main flame operation in the 1474, 1475, 1476 models.)
CONVEYOR DRIVE	Closing the on/off switch supplies 120 VAC (through the step down transformer) to the conveyor control board. AC volts are converted to DC volts and are supplied to the conveyor motor at terminals A+ and A-. Adjustment of the speed control potentiometer will change resistance at terminals P1 & P2 varying the DC voltage to the motor. The speed of the conveyor motor will increase or decrease as the DC voltage from the board increases or decreases respectively. NOTE: The conveyor control uses a sensor and magnet, mounted on the conveyor motor that senses the motor speed. Any change in motor load (± RPM) is detected by the sensor and the voltage to the motor is adjusted accordingly.

SCHEMATIC 1450 / 1451 / 1480

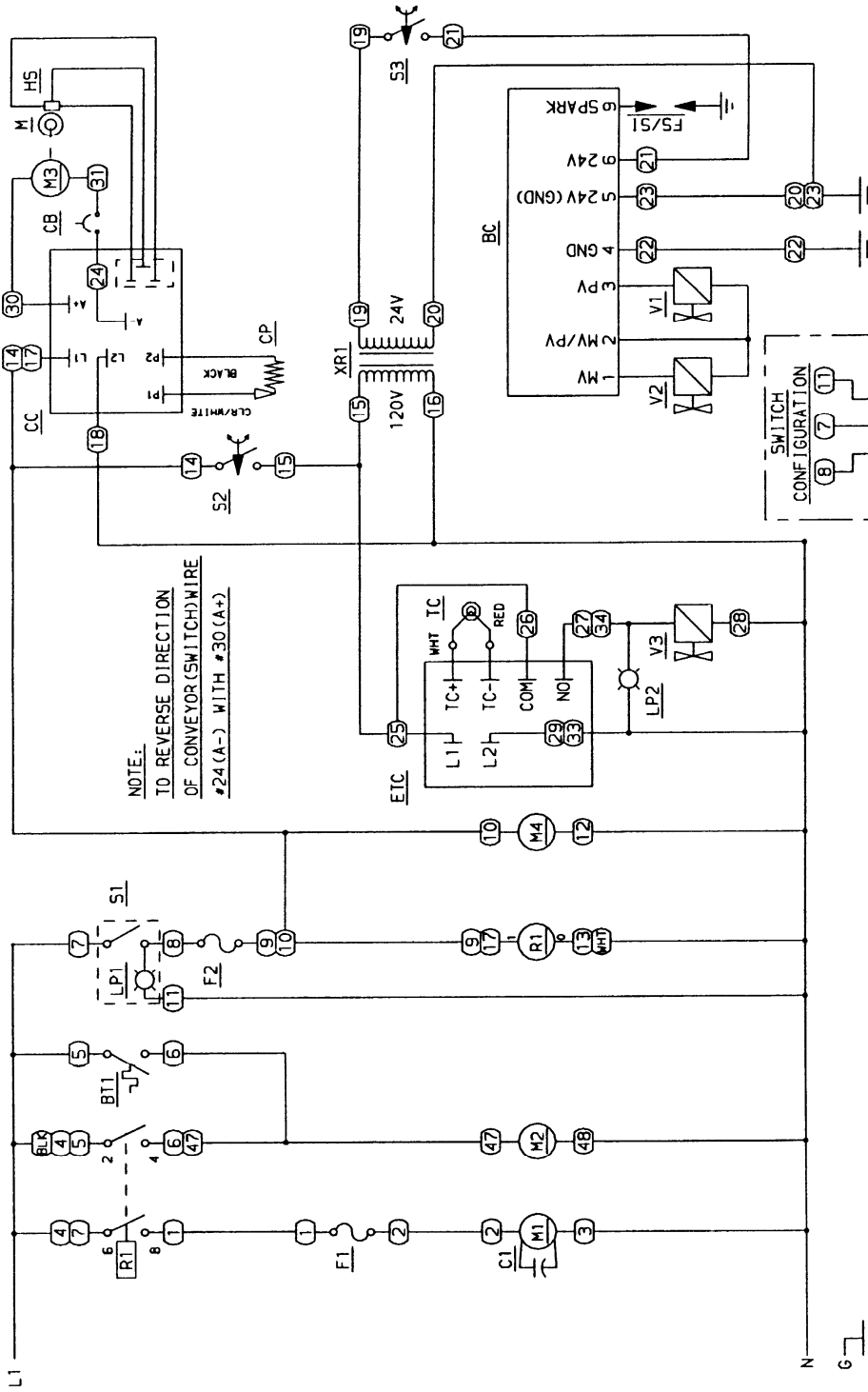

- BC - BURNER CONTROL
- BT1 - THERMOSTAT CONTROL BOX COOLING
- C1 - CAPACITOR, 7.5 MFD
- CB - CIRCUIT BREAKER
- CC - CONVEYOR CONTROL
- CP - CONVEYOR POT ASSEMBLY
- ETC - ELECTRONIC TEMPERATURE CONTROL
- F1 - FUSE, FAN MOTOR, 10A
- F2 - FUSE, CONTROL, 3A
- FS/S1 - FLAME SENSOR/SPARK IGNITOR
- HS - HALL EFFECT SENSOR
- LP1 - LAMP, SWITCH
- LP2 - LAMP, READY
- M - MAGNET

- M1 - MOTOR, OVEN FAN
- M2 - MOTOR, COOLING FAN
- M3 - MOTOR, CONVEYOR
- M4 - MOTOR, BURNER BLOWER
- R1 - RELAY, OVEN FAN MOTOR
- S1 - SWITCH, OVEN FAN
- S2 - SWITCH, OVEN MOTOR CENTRIFUGAL
- S3 - SWITCH, BURNER BLOWER CENTRIFUGAL
- TC - THERMOCOUPLE, TYPE J
- V1 - VALVE, MAIN
- V2 - VALVE, CONTROL
- V3 - VALVE, BURNER CONTROL
- XR1 - TRANSFORMER, BURNER CONTROL
- (XX) - WIRE NUMBERS

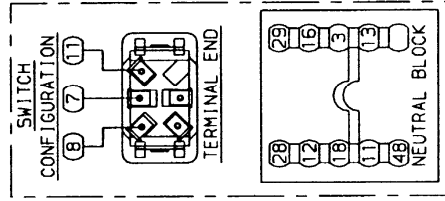

Lincoln
Foodservice Products, Inc.
FORT WAYNE, INDIANA
MODELS 1450-1451
120V 50 HZ

2802509F

SCHEMATIC 1452 / 1453

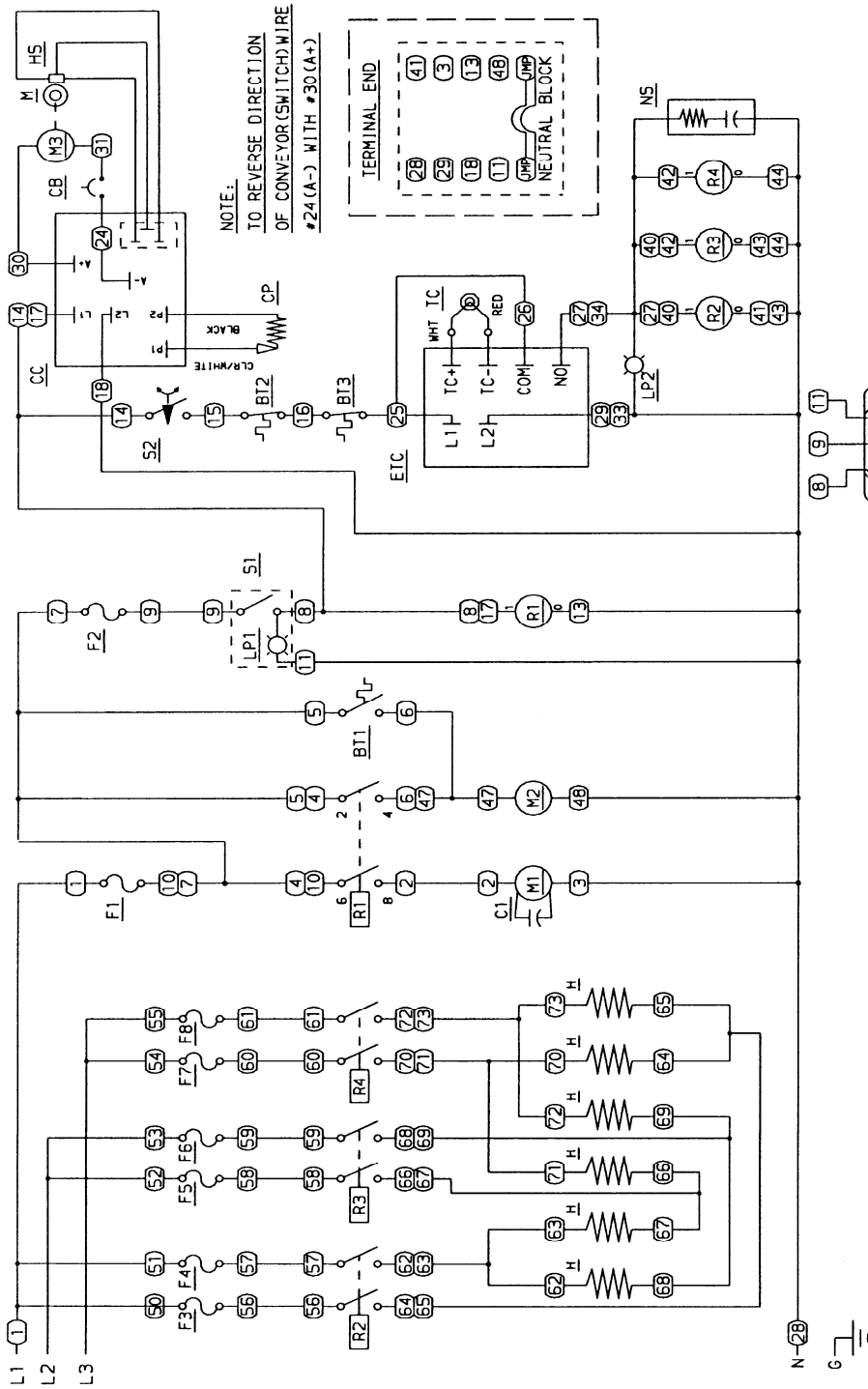

Lincoln
Foodservice Products, Inc.
FORT WAYNE, INDIANA
1452 - 120/208V 60 HZ
1453 - 120/240V 60 HZ

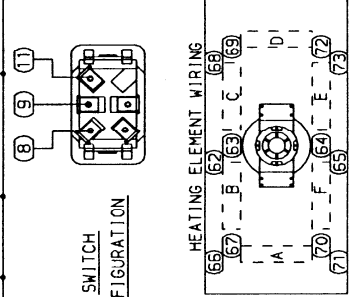

SWITCH
CONFIGURATION

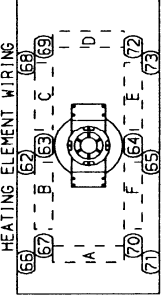

- LP1 - LAMP, SWITCH
- LP2 - LAMP, READY
- M - MAGNET
- M1 - MOTOR, OVEN FAN
- M2 - MOTOR, COOLING FAN
- M3 - MOTOR, CONVEYOR
- R1 - RELAY, OVEN FAN MOTOR
- R2-R4 - CONTACTOR, MERCURY, 2P
- S1 - SWITCH, OVEN FAN
- S2 - SWITCH, OVEN MOTOR CENTRIFUGAL
- TC - THERMOCOUPLE, TYPE J
- NS - NOISE SUPPRESSOR
- (X) - WIRE NUMBERS

- BT1 - THERMOSTAT, CONTROL BOX COOLING
- BT2 - THERMOSTAT, HIGH LIMIT
- BT3 - THERMOSTAT, CONTROL HIGH LIMIT
- CB - CAPACITOR, 7.5 MFD
- CC - CIRCUIT BREAKER
- CP - CONVEYOR CONTROL
- ETC - CONVEYOR POT ASSEMBLY
- F1 - ELECTRONIC TEMPERATURE CONTROL
- F2 - FUSE, FAN MOTOR, 10A
- F3-FB - FUSE, CONTROL, 3A
- H - FUSE, HEATER 50A
- H - HEATING ELEMENT
- HS - HALL EFFECT SENSOR

SCHEMATIC 1454 / 1455

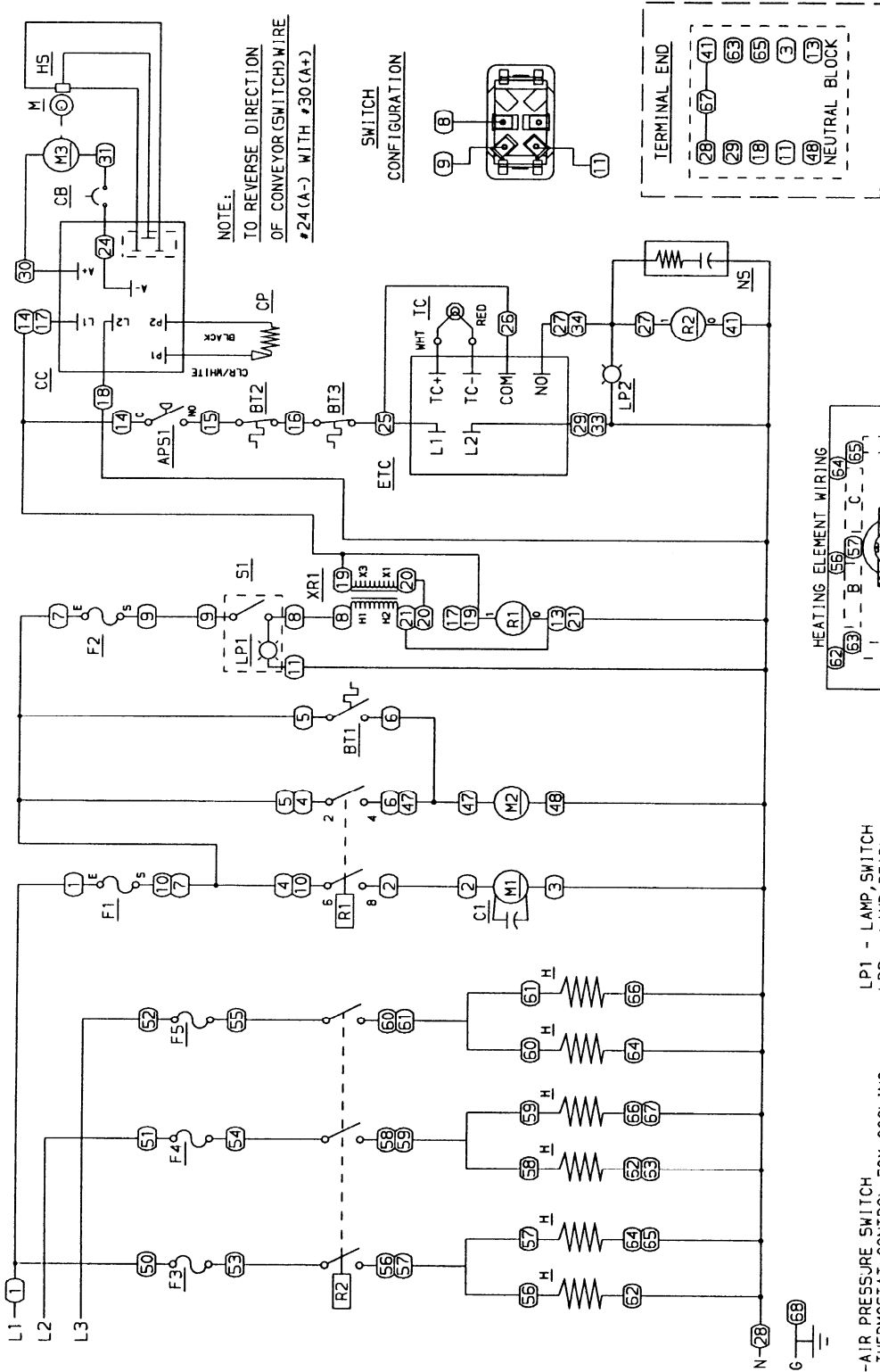

NOTE:
TO REVERSE DIRECTION
OF CONVEYOR (SWITCH) WIRE
#24 (A-) WITH #30 (A+)

SWITCH
CONFIGURATION

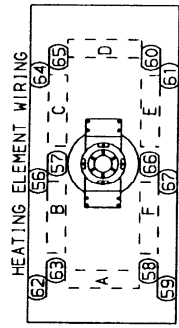
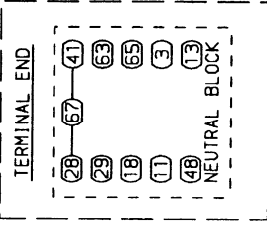

- AP51 - AIR PRESSURE SWITCH
- BT1 - THERMOSTAT, CONTROL BOX COOLING
- BT2 - THERMOSTAT, HIGH LIMIT
- BT3 - THERMOSTAT, CONTROL HIGH LIMIT
- C1 - CAPACITOR, 7.5 MFD
- CB - CIRCUIT BREAKER
- CC - CONVEYOR CONTROL
- CP - CONVEYOR POT ASSEMBLY
- ETC - ELECTRONIC TEMPERATURE CONTROL
- F1 - FUSE, FAN MOTOR, 10A
- F2 - FUSE, CONTROL, 3A
- F3-F5 - FUSE, HEATER 50A
- H - HEATING ELEMENT, 4500 WATT
- HS - HALL EFFECT SENSOR
- LP1 - LAMP, SWITCH
- LP2 - LAMP, READY
- M - MAGNET
- M1 - MOTOR, OVEN FAN
- M2 - MOTOR, COOLING FAN
- M3 - MOTOR, CONVEYOR
- R1 - RELAY, OVEN FAN MOTOR, 2P
- R2 - RELAY, CONTACTOR, MERCURY, 3P
- S1 - SWITCH, OVEN
- NS - NOISE SUPPRESSOR
- XR1 - TRANSFORMER, CONTROL POWER
- (XX) - WIRE NUMBERS

Lincoln
Foodservice Products, Inc.
FORT WAYNE, INDIANA
MODELS 1454-1455
415/240V-380/220V 50 HZ

2802631E

SCHEMATIC 1456 / 1457

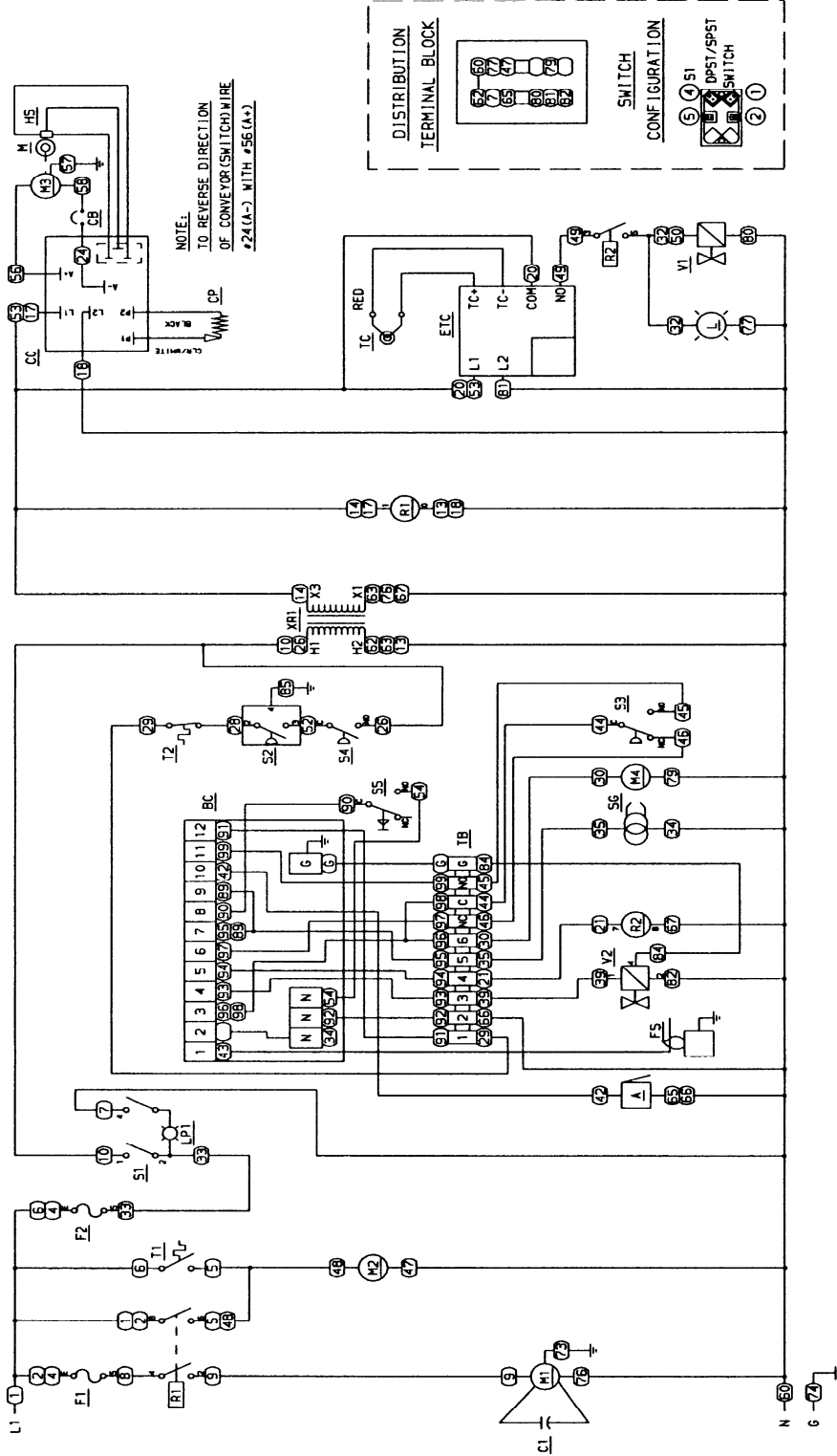

Lincoln
Foodservice Products, Inc.
FORT WAYNE, INDIANA
MODELS 1456, 1457
240V 50HZ

- A - ALARM
- BC - BURNER CONTROL
- CI - CAPACITOR, 7.5 MFD
- CB - CIRCUIT BREAKER
- CC - CONVEYOR CONTROL ASSEMBLY
- CD - CONVEYOR CONTROL ASSEMBLY
- EIC - ELECTRONIC TEMPERATURE CONTROL
- F1 - FUSE, FAN MOTOR, 10A
- F2 - FUSE, CONTROL, 3A
- F5 - FLAME SENSOR
- L - LAMP, READY
- M - MAGNET
- M1 - MOTOR, OVEN FAN
- M2 - MOTOR, COOLING FAN
- M3 - MOTOR, BURNER OVER
- M4 - MOTOR, BURNER OVER
- R1 - RELAY, OVEN FAN MOTOR
- R2 - RELAY, GAS CONTROL
- S1 - SWITCH, OVEN FAN
- S2 - SWITCH, GAS INLET PRESSURE
- S3 - SWITCH, BURNER PRESSURE
- S4 - SWITCH, OVEN AIR PRESSURE
- S5 - LOCKOUT RESET SWITCH
- T1 - THERMOSTAT, CONTROL BOX COOLING
- T2 - THERMOSTAT, COOLING LIMIT
- TC - THERMOCOUPLE
- TC+ - THERMOCOUPLE J
- V1 - VALVE MAIN & PILOT
- V2 - VALVE MAIN & PILOT
- XR1 - TRANSFORMER, POWER
- XR2 - TRANSFORMER, POWER

2802628H

SCHEMATIC 1474 / 1475 / 1476

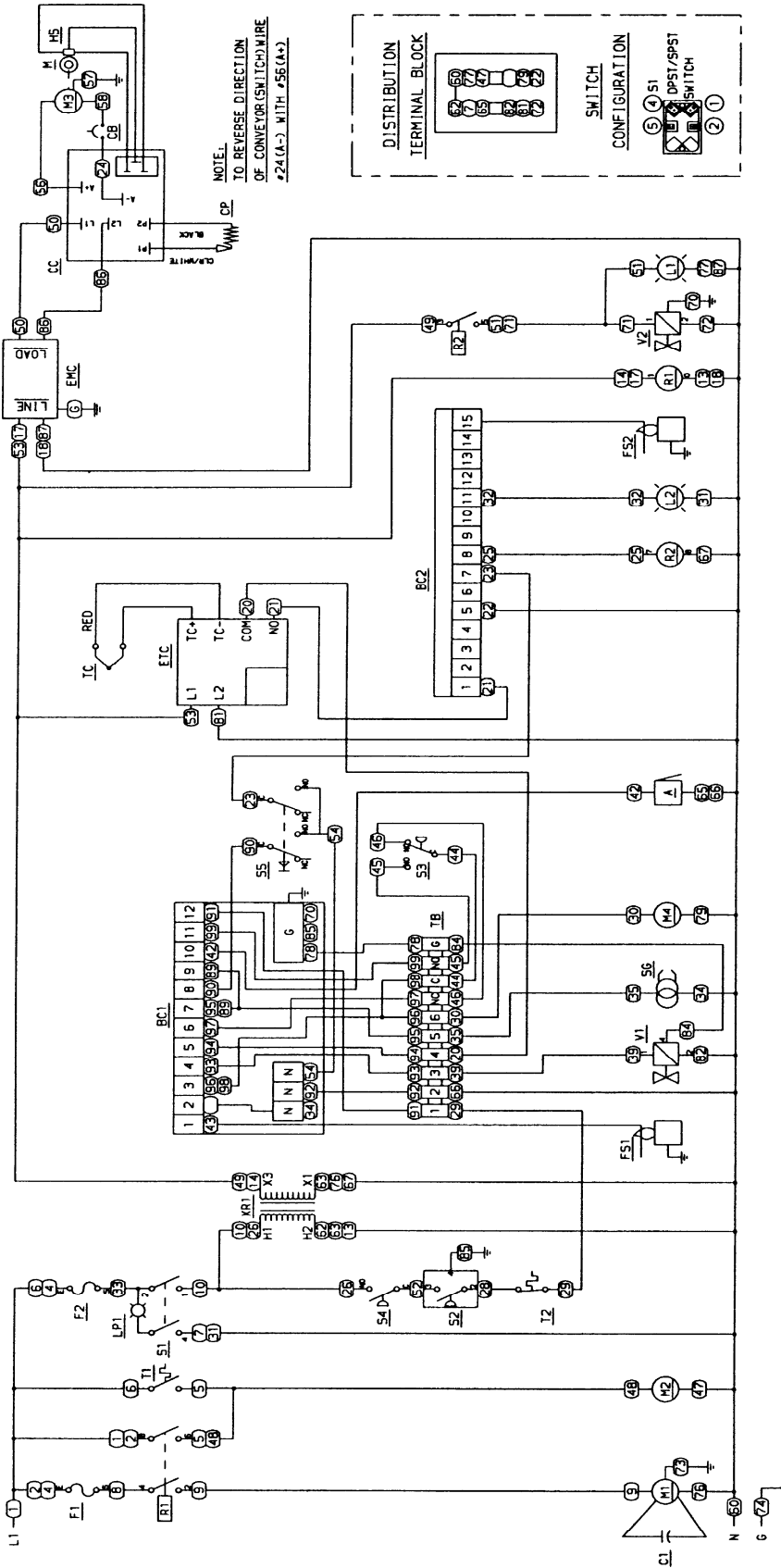

- A - ALARM
- BC1 - BURNER CONTROL - PILOT
- BC2 - BURNER CONTROL - MAIN
- CB - CIRCUIT BREAKER
- CD - CONVEYOR CONTROL
- CP - CONVEYOR POT ASSEMBLY
- EMC - EMI FILTER
- ETC - ELECTRONIC TEMPERATURE CONTROL
- F1 - FUSE, FAN MOTOR, 10A
- F2 - FUSE, CONTROL, 3A
- FS1 - FLAME SENSOR - PILOT
- FS2 - FLAME SENSOR - MAIN
- HS - HALL EFFECT SENSOR
- L1 - LAMP, READY
- L2 - LAMP, MAIN BURNER ALARM
- LP1 - LAMP, POWER
- M - MOTOR, OVEN FAN
- M1 - MOTOR, COOLING FAN
- M2 - MOTOR, CONVEYOR
- M3 - MOTOR, BURNER BLOKER
- M4 - RELAY, OVEN FAN MOTOR
- R1 - RELAY, GAS CONTROL
- R2 - SWITCH, GAS INLET PRESSURE
- S1 - SWITCH, OVEN AIR PRESSURE
- S2 - SWITCH, BURNER BLOKER PRESSURE
- S3 - SWITCH, OVEN AIR PRESSURE
- S4 - LOCKOUT RESET SWITCH
- S5 - SPARK GENERATOR
- T1 - THERMOSTAT, CONTROL BOX COOLING
- T2 - THERMOSTAT, HIGH LIMIT
- TB - THERMINAL BLOCK
- TC - THERMOCOUPLE, TYPE J
- V1 - VALVE, MAIN & PILOT
- V2 - VALVE, CONTROL
- XRT - TRANSFORMER, POWER
- (X) - WIRE NUMBERS

Lincoln
 Foodservice Products, Inc.
 FORT WAYNE, INDIANA
 MODELS 1474, 1475, 1476
 1-433-000-E, 1-434-000-E

2802711G

TROUBLESHOOTING GUIDE

GAS OVENS

IMPINGER ADVANTAGE SERIES

SYMPTOM	POSSIBLE CAUSE	EVALUATION
Oven fan will not run NOTE:	Incoming Power Supply	Check breakers, reset if required. Call Power Co. if needed
	(Export Ovens)	For some export ovens, there is a control circuit step-down transformer. This transformer steps down supply voltage to 120 VAC. If main fan will not run, the secondary of this transformer must be checked for 120 VAC output. Check specific oven model schematic for circuit location.
	Oven Fan Fuse	Check and/or Replace
	Control Fuse	Check and/or Replace
	Fuse Holder	Check and/or Replace
	Fan Switch	Check continuity between switch terminals
	Main Relay	Check continuity to 120 VAC coil. Check for power to relay coil (120VAC). Check for supply voltage to relay contacts. Visually check for contact pull-in.
	Fan Motor	Check for opens, shorts, or ground. WITH POWER OFF: Turn Fan Blade to check for locked rotor.
	Capacitor	Check for opens, shorts, or grounds.
No control box cooling	Main Fan Relay	Check for power to main fan relay. Visually check for contact pull-in. Axial Cooling Fan. Check for power (120 VAC or 240 VAC, check specific model) to cooling fan. If voltage is present at the fan motor and the fan does not run, replace fan assembly.
No automatic control box cooling	Incoming Power Supply	Check breakers/Reset if needed. Check for incoming power at cooling fan thermostat.
	Cooling Fan Thermostat	Check cooling fan thermostat (thermostat closes at 120°F and opens at 100°F). With cooling fan thermostat pre-heated, check for continuity. If switch is open, replace.
	Axial Cooling Fan	WITH POWER OFF: check for locked rotor. Check for proper voltage to the cooling fan, if present and fan does not run, replace the fan.
Control box cooling fan continues to run	Cooling Fan Thermostat	See "Cooling Fan Thermostat" (NOTE: Thermostat will remain closed if control box temperature exceeds 120°F)
Oven will not heat Model 1450-1451	Gas Supply	Check for adequate gas supply to oven
	Manual Gas Shut-off Valve	Check to see that manual shut-off valve is open
	Main Oven Fan	Check if main oven fan is operating. If not, refer to "Oven fan will not run" on page 11.
For 1456, 1457, 1475, 1476 See Page 14.	Centrifugal Switch	Check for 120 VAC on both sides of (Main Fan) switch. If voltage present on one side only, and motor is running, replace motor.
	Transformer, 24 VAC	Check for 120 VAC to primary of transformer. Check for 24 VAC from secondary of transformer. If there is primary voltage, but no secondary voltage, replace transformer.
	Burner Blower Motor	Check for 120 VAC supply to burner blower motor. If 120 VAC is present and motor does not run, replace motor. WITH POWER OFF: turn blower wheel to check for locked rotor.

	Centrifugal Switch of Burner Blower Motor	Check for 24 VAC output from secondary of transformer. If voltage is present, check for 24 VAC at pin 6 and ground on ignition control. If the burner blower motor is running and there is no voltage at pin 6 and the ground on the ignition control, replace the burner blower motor.
	Ignition Control	Check for 24 VAC supply to the ignition control at pin 6 and the ground. If voltage is present, check for 24 VAC across pin #3 and ground (pilot valve). NOTE: The Honeywell ignition control has a 30 sec. pre-purge (Time Delay) built in. If voltage is not present, replace electronic control package. If the pilot valve is energized, check to see that the high voltage igniter circuit is also energized. To check, disconnect the igniter lead from the ignition control. Place female terminal of igniter lead approximately 1/8" from terminal post on ignition control. Spark should jump the 1/8" gap. If no spark is present, replace ignition control. NOTE: control will try for ignition for 15 seconds only.
	No Pilot	If the ignition control is supplied with 24 VAC and the pilot valve (internal to valve assembly) and igniter circuits are energized, visually check for pilot flame. This may be done by opening the small inspection door on the end of the burner, or by opening the main oven door and looking under the lower finger housings on the right side of the oven. If no pilot flame is visible, check pilot shut-off valve.
	Pilot Shut-off Valve	Check to see that pilot shut-off valve is open (shut-off valve is located between valve assembly and burner).
	Pilot Tube	Check for gas pressure at pilot tube. Disconnect pilot tube at burner and connect manometer to pilot tube. If no gas pressure is present, check for blockage in pilot tube or pilot shut-off valve. If these are clear, and there is gas supplied to the oven, replace the gas valve.
	Pilot Orifice	If there is gas pressure at the pilot tube, check the pilot orifice for obstructions. Replace as needed.
	Burner Igniter	Check the burner igniter head for any obstructions, also check for frayed or broken wire, (spark gap .100 in. 2.5 mm). If there is visible damage, replace igniter assembly.
Pilot flame but no main flame	Ignition Control	If there is a pilot flame, check for 24 VAC across terminals #1 and the ground (main valve). If there is no voltage present, replace the ignition control. NOTE: The Honeywell ignition control has a 15-sec. lockout built in. If pilot flame is not proven, turn off switch, wait 30 sec. and restart. If power is supplied to terminal #1 but there is no main flame, verify that the main valve (internal to valve assembly) has opened. Connect a manometer to the manifold gas pressure tap located on the back of the valve assembly. If no gas is present, replace valve assembly. Check for temperature control set above 300°F.
	Main Orifice	Check for blockage of main orifice. If there is no blockage to the main orifice, check the temperature control.
	Temperature Control (Electronic)	Check for 120 VAC across L1 and L2 on temperature control board.

	Thermocouple Probe	Remove thermocouple leads from the temperature control board, and measure the millivolt output of these leads. Refer to charts on page 25 in the adjustment section for proper readings.
	Temperature Control	Turn temperature control dial to full "on" position. NOTE: Thermocouple must be connected. Measure for 120 VAC across terminals "N.O." and Com., if voltage is not present; replace control.
	Solenoid Valve	If voltage is present at terminals "N.O." and Com., check for voltage at solenoid valve. If voltage is present, listen for valve to open and close. Also, check for opens and shorts in coil. If solenoid valve is defective, replace.
Intermittent Heating	AS FOLLOWS	Both the main fan motor and burner blower motor are equipped with thermo-protection and will cease to operate when not cooled properly. This can cause the units to cycle on and off intermittently. Also, most of the problems listed under "oven will not heat" can cause intermittent failures.

For continuing intermittent problems, a series of test lights may be made and installed in the ovens. The lights will allow the customer to advise the service technician a trouble code when the oven fails

The lights should be connected in the following manner:

Light#1 attached in 120 VAC line after oven fan switch.

Light #2 attached after 120 VAC contacts of oven motor centrifugal switch

Light #3 in 24 VAC Burner Transformer Secondary.

Light #4 in 24 VAC at terminal #6 of Ignition control valve.

Light #5 in 24 VAC at terminal #3 of Ignition control valve.

Light #6 in 24 VAC at terminal #1 of Ignition control valve.

CODE:

All lights off - lights of main power, main fan off, oven fan switch out.

1 on 2 off 3 off 4 off 5 off 6 off - Oven Motor Centrifugal Switch open

1 on 2 on 3 on 4 off 5 off 6 off - Burner Motor Centrifugal Switch bad.

1 on 2 on 3 on 4 on 5 Off 6 off - Ignition Control bad

1 on 2 on 3 on 4 on 5 on 6 off - Pilot Shield missing or warped, no flame rectification, Pilot
- Orifice plugged, or Gas Control Valve bad.

1 on 2 on 3 on 4 on 5 on 6 on - Unit still not working Main Orifice plugged, Gas Valve bad,
- Temperature Control bad.

- However, Main Orifice would not be intermittent problem.

Conveyor will not run	Voltage Supply	Check incoming voltage supply at line 1 to neutral. There should be a voltage reading of 120 VAC. If not present, check breakers.
	3 Amp Fuse	This control fuse is located on the front panel. Replace if defective.
	Fuseholder	Check and/or replace.
	Fan Switch	See procedure for checking on page 11.
	Speed Adjustment Potentiometer	This is a 0 to 10 K ohm, 1 turn potentiometer. With power off, remove the black and white pot leads from the motor control board at terminals P1, P2. Place the meter leads on the black lead (P2) and on the white lead (P1). Rotating the pot., slowly, from low to high, the meter reading should show an even transition from 0 to 10K ohms \pm 5%. There should be no dead or open spots through out the 1 turn of the pot. Check both leads to ground. There should be no continuity to ground. If any of the above checks fail, replace the pot.

	DC Motor Control Board	Check for 120 VAC input to the control board at terminals L1 and L2. If not present, check the oven fan switch and wiring back to 3 amp fuse and then back to power source if necessary. If 120 VAC is present at L1 and L2, check both fuses on control board (4A line) and (1A armature), check the VDC output at terminals A+ and A-. If 120 VAC is present at terminals L1 and L2, and DC voltage is present A+ and A-, but motor does not run, check gear motor as follows.
	Conveyor Gear Motor	If DC voltage is present at A+ and A- and the motor does not run, first check the mini breaker and then the conveyor. Refer to the next possible cause. Check the leads to the motor for evidence of any shorts or opens, and each lead to ground. If the motor fails the above tests, replace motor. From the top of the motor, rotate motor shaft to determine if there is a locked rotor or a locked gear box (use care so magnet and the H.S. board are not damaged). Replace as needed.
	Conveyor	Check for any mechanical mis-alignment . Also check for worn bearings. A conveyor belt that is over tightened may cause excessive bearing wear and sometimes, irregular speed.
Conveyor speed varying or intermittent	Power Supply	Check power supply at the DC control board for the 120 VAC at board terminals L1 and L2
	D.C. Motor Control Board	Place the test meter probes on terminals A+ and A- . (With speed potentiometer set to maximum speed (Approx. 2 min.) The meter reading should be approximately 100 VDC ($\pm 3\%$). The board output is steady. If the board voltage output is unsteady beyond limits ($\pm 3\%$) then the board is probably bad. Always check the speed pot. , be sure it is okay before changing a board. This test is not always 100% accurate as this test is not performed at operating speeds. However, this test is the best method currently available.
	DC Gearmotor	If the DC control board is steady then the problem may be the motor or gearbox. Check the brushes in the motor for excessive arching and/or unusual wear. Check the motor and gearbox from instruction located on page 14 under "possible cause" Listing "conveyor gear motor."
	Magnet	Check to insure that the magnet (cemented to shaft of conveyor drive motor) has not been damaged, or come loose from motor shaft. Replace as needed.
	Hall Effect Sensor	Check for any physical damage to Hall Effect Sensor (mounted on conveyor drive motor Check all wiring and connections for damage. Check all connections for tightness or proper location and check all wiring for visible damage. Replace as needed. Connect new Hall Effect to system and check for steady operation.
MODELS 1456 - 1457-1474-1475-1476		
Oven will not heat	Gas Supply	Check for adequate gas supply to oven.
	Manual Gas Shut-Off Valve	Check to see that manual shut-off valve is open.
	Fan Switch	Check to see that the fan switch is on.
	Main Oven Fan	Check if main oven fan is operating. If not, refer to "Oven fan will not run."
	Air Pressure Switch	Check for supply voltage on both sides of switch. If voltage present on one side only, check for air tube blockage or misalignment, adjust air switch. Replace as needed.

	Gas Pressure Switch	This switch is located inside the gas valve and should close when gas pressure is present. WITH POWER OFF: remove 3 prong plug (on gas valve) and measure continuity between terminals 2 and 3. NOTE: Remove insulation pad below plug to read numbers. If no continuity, check the following: 1. Proper gas pressure supply to the gas valve as marked on the oven specification plate. 2. Check for proper adjustment of gas pressure switch. 8.8 on dial for natural gas, 23 for LP, and 4.5 for Town Gas. 3. Check gas filter in gas valve for blockage or damage. (See Adjustment Section on page 28). If above checks are okay, but pressure switch is still not closed, replace gas valve.
	Hi-Limit Thermostat	Thermostat is normally closed, opens at 368°C (695°F). If open, reset and test oven for proper operation. If thermostat will not hold for maximum oven temperature, and oven is not exceeding temperature dial setting, check for proper location of capillary bulb in its spring holder. If above checks okay, replace hi-limit thermostat.
	Ignition Control	Check for proper line voltage supply to ignition control, terminal #1. Check for proper line voltage to the Burner Blower Motor. If voltage is present, proceed with next step, if not, wait 30 seconds, push reset button, and try to restart. If this fails, check wires from thermostat and burner blower motor to the ignition control. If all above fails and wires are okay, replace ignition control.
	Burner Blower Motor	Check for line voltage to motor. WITH POWER OFF: turn blower wheel to check for locked rotor or blower wheel slippage. If proper line voltage is present at motor connecting plug, terminal 2 and 5, and motor does not run, replace motor.
	Air Pressure Switch (Burner Blower)	Check for proper line voltage switching from "N.C." to "N.O." as air pressure switch closes. Check for air switch adjustment, air tube blockage, or misalignment, and if these fail, replace air pressure switch.
	Spark Generator	A pre-purge time of 30 to 60 seconds occurs after blower motor starts, check for proper line voltage at spark generator. If voltage is not present, check reset button for the Ignition Control. If voltage is still not present, replace ignition control. If voltage is present, visually check for spark at igniter head located in end of burner.
	Igniter/Sensor Assembly	Check this assembly for visible damage. If there is no damage, replace the spark generator. If there is damage, replace the Igniter/Sensor Assembly. Also check for frayed or damaged wires in the burner tube. Check spark gap (should be .100 inch 2.5 mm). Replace as needed.
	Gas valve	This solenoid is located inside the gas valve and should open when proper line voltage is present. If no voltage is present, check the reset button on the ignition control, and all connections for tightness. If there is still no voltage present at gas valve, replace ignition control. If there is voltage present, check for gas pressure at the gas pressure tap located in the gas piping just prior to the burner. If there is no gas pressure, replace gas valve.

Flame will not stay on	Flame Sensor	To check for flame sensor operation, connect a digital multimeter (capable of measuring D.C. micro amps) between the flame sensor wire and Ignition Control. Sensor current from sensor control is 3 micro amps minimum. If these readings are not achieved replace igniter/sensor assembly. Also check for any type of damage to flame sensor wire and connections.
	Ignition Control	If there is sufficient flame sensor current, but the burner will not remain ignited, check the reset button on ignition control. If all above are okay, replace ignition control.
No Pilot	Pilot Orifice	If all above are operating properly, but there is no pilot flame, check for any obstructions in pilot orifice.
Pilot flame, but burner will not stay ignited	Flame Sensor	(There should be a visible pilot flame at this time.) To check for flame sensor operation, connect a digital multimeter (capable of measuring D.C. micro amperes) between the flame sensor wire and the ignition control. NOTE: this is a current measurement and the meter must be connected in series. Proper current readings should be minimum of 3 micro AMP. D.C. If these readings are not achieved, replace igniter/sensor assembly. Also check for any type of damage to flame sensor wire and connections.
	Power Supply	If there is sufficient micro-amp current, but the flame will not stay lit, check for proper polarity of the input power supply.
	Ignition Control	If there is sufficient flame sensor current, but the burner will not remain ignited, check reset button on ignition control, if all above are okay, replace ignition control.
Indicator light is on, but no main flame(Model 1456-1457)	Gas Control Relay	Check for 220 VAC to relay coil. If no voltage is present, trace wiring back to ignition control. If voltage is present, check to insure contacts are closing.
	Temperature Control	Check for 120 VAC across L1 and L2 on temperature control board. If no voltage is present, retrace wiring back to power supply. Turn the temperature adjustment knob to the maximum temperature position and check for 120 VAC at the load terminal to neutral. If 120 VAC is not present, proceed as follows: If 120 VAC is present and unit is not heating, see "Solenoid Valve."
	Thermocouple Probe	Remove thermocouple leads from the temperature control board and measure the millivolt output of these leads. Refer to chart in page 25 for proper readings. If the thermocouple probe checks good, then the problem is usually with the temperature control board.
	Solenoid Valve	If output voltage is present at temperature control board, check for voltage at solenoid valve. If voltage is present, listen for valve to open and close. Also check for opens, shorts in coil. Replace as needed.
Indicator light is on, but no main flame (1474-1475-1476)	Temperature Control	Check for 120 VAC across L1 and L2 on temperature control board. If no voltage is present, retrace wiring back to power supply. Turn the temperature adjustment knob to the maximum temperature position and check for 220 VAC at the load terminal to neutral. If 220 VAC is not present, proceed as follows: If 220 VAC is present, and unit is not heating, see "Flame Monitor". Check for 220 VAC at terminal "COM" on temperature control board. If no voltage is present, trace wiring back to ignition control.

	Thermocouple Probe	Remove thermocouple leads from the temperature control board and measure the millivolt output of these leads. Refer to chart on Page 25 for proper readings. If the thermocouple probe checks good, replace temperature control.
	Flame Monitor	Check for 220 VAC at terminal #1. If no voltage is present, trace wiring back to temperature control. Check for 220 VAC output at terminal #8. NOTE: There is a delay of up to 2 seconds for 220 VAC output at terminal #8. If there is no voltage output at terminal #8, check the reset button. Replace control as needed.
	Relay, Main Burner	Check for 220 VAC at relay coil, if no voltage is present, trace wiring back to flame monitor. Check for 120 VAC to relay contacts. If no voltage is present, trace wiring back to power supply. Check to ensure contacts are closing
	Valve, Temperature Regulation	Replace relay as needed. Check for 120 VAC at valve, if no voltage is present, trace wiring back to relay. If voltage is present, listen for valve to open and close. Check for opens or shorts in coil. Replace as needed.
Main Flame will not stay lit	Flame Monitor	(There should be a visible main flame at this time.) To check for flame monitor operation, connect a digital voltmeter (capable of measuring D.C. microamperes) between the flame sensor and terminal #15 on the flame monitor. The flame monitor requires a minimum of 4 micro amp. D.C. for proof of flame. If these readings are not achieved, replace sensor assembly. Also check for any type of damage to flame sensor wire and connections. If the reading is above the minimum required, and the flame monitor will not supply 220 VAC to the relay coil, replace the flame monitor.
Intermittent heating	As Follows	Both the main fan motor and burner blower motor are equipped with thermal protection and will cease to operate if overheating occurs. This can cause the units to cycle on and off intermittently. This may be caused by improper ventilation. Also most of the problems listed under "oven will not heat" can cause intermittent failure. See page 13 for test lights.

TROUBLESHOOTING GUIDE

ELECTRIC OVENS

IMPINGER ADVANTAGE SERIES

SYMPTOM	POSSIBLE CAUSE	EVALUATION
Oven fan will not run	Incoming Power Supply	Check breakers/Reset if required. Call Power Co. if needed.
	Oven Fan Fuse	Check and/or Replace
	Fuse Holder	Check and/or Replace
	Fan Switch 1454-1455	Check continuity between switch terminals. For these oven models, there is a control circuit step-down transformer. This transformer steps down supply voltage to 120 VAC. If main fan will not run, the secondary of this transformer must be checked for 120 VAC output. Check specific oven model schematic for circuit location.
	Main Relay	Check continuity to 120 VAC coil. Check for power to the relay coil,(120 VAC). Check for 120/208/220/240 VAC to relay terminals. Visually check for contact pull-in.
	Fan Motor	Check for opens, shorts, or ground. WITH POWER OFF: Turn Fan Blade to check for locked rotor.
	Capacitor	Check for opens, shorts, or grounds.
No control box cooling	Main Fan Relay	Check for power to main fan relay. Visually check for contact pull-in.
	Axial Cooling Fan	WITH POWER OFF: turn fan blade to check for locked rotor. Check for power to cooling fan. If voltage is present at the fan motor and the fan does not run, replace fan assembly.
No automatic control box cooling	Incoming Power Supply	Check circuit breakers, reset if required, call Power Company if needed.
	Cooling Fan Thermostat	Thermostat is normally open and closes at 120°F ± 3 (48.9°C ± 7°), and opens at 100°F ± 3°F (37.8°C ± 1.7°C).
Oven will not heat	Main Oven Fan	Check if main oven fan is operating. If not, refer to "Oven fan will not run". Page 18.
	Centrifugal Switch (Main Fan) Model 1452-1453	Check for 120 VAC on both sides of switch. If voltage is present on one side only and motor is running, replace motor.
	Air Pressure Switch (1454-1455)	This normally open switch should close when the main fan is activated. If adjustment is necessary (Refer to page 28). Check tube for blockage. Replace if defective.
	Hi Limit Thermostat (Oven Cavity)	Terminals are normally closed. If open, reset and test oven for proper operation. If thermostat will not hold for maximum oven temperature, and oven is not exceeding temperature dial setting, replace thermostat.
	Control Box High Limit Thermostat	Terminals are normally closed, but open at 130°F ± 5°F (53.9°C ± 2.8°C). Check for over heating and reset thermostat. Test for proper operation. If it will not reset and hold, then replace.

	Temperature Control Board	Check for 120 VAC input to temperature control board. If not present, check wiring from Hi-Limit to temperature control board. Turn the temperature adjustment dial to the maximum temperature position. Check for 120 VAC at coil of mercury contactor(s). Next, short the leads of thermocouple on the temperature control board, check for 120 VAC at coil of mercury contactor(s). If voltage is not present, replace temperature control board. If voltage is present, proceed.
	Thermocouple Probe	Remove thermocouple leads from the temperature control board, and measure the millivolt output of the leads. Refer to chart (page 25) in adjustment section for proper millivolt readings.
	Mercury Contactor(s)	Check for 120 VAC to the contactor coil. If voltage is present and contactor will not activate, replace the contactor(s). Also check each contactor for proper high voltage input and output.
	50 Amp Fuses	If there is no high voltage input to the mercury contactor(s), check the 50 amp fuses and replace if necessary.
	Heater Elements	Check the Amp. draw on each hot leg for proper load. Check the specification plate for rating information. If the Amp. draw is low or high, check the individual elements for opens, shorts, and proper resistance. To check resistance of the elements, turn off the power! Remove all leads from the elements and use an accurate digital VOM. The element resistance should be as follows: 208V - 9.8 ohms approx. 220V - 10.5 ohms approx. 240V - 13 ohms approx. If all readings are not correct, replace elements as needed.
Oven heats with switch off	Mercury Contactor(s)	The mercury contactor has probably malfunctioned in the closed position. If there is no voltage to the operating coil, but there is high voltage at the contactor output, replace the mercury contactor.
Conveyor will not run	Voltage Supply (Export Ovens)	Check incoming voltage supply, check breakers and reset if required. For some export ovens there is a control circuit step down transformer. This transformer steps down supply voltage to 120 VAC. If conveyor will not run, the secondary of this transformer must be checked for 120 VAC output. Check specific oven model schematic for circuit location.
	Speed Adjustment Potentiometer	This is a 0 to 10K ohm, 1 turn potentiometer. With power off, remove the black and white pot leads from the motor control board at terminals P1 and P2 with a digital multimeter, check the ohm reading on the black lead (P2) and the white lead (P1). Rotating the pot, slowly, from low to high, the meter reading should show an even transition from 0 to 10K ohms \pm 5%. There should be no dead or open spots through out the 1 turn of the pot. Check both leads to ground. There should be no continuity to ground. If any of the above checks fail, replace the pot.
	DC Motor Control Board	Check for 120 VAC input to the control board at terminals L1 and L2. If not present, check back to power source if necessary. If 120 VAC is present at L1 and L2, check the VDC output at terminals A+ and A-. If 120 VAC is present at terminals L1 and L2, but DC voltage is not present at A+ and A-, verify fuses are not blown, if fuses check ok, replace the board. If DC voltage is present at A+ and A-, but motor does not run, check gear motor as follows:

	Conveyor Gear Motor	If DC voltage is present A+ and A- and the motor does not run, first check the mini breaker and then the conveyor. Refer to the next possible cause. Check motor brushes for excessive or abnormal wear, replace as needed. Check the leads to the motor for evidence of any shorts or opens, and each lead to ground. If the motor fails the above tests, replace motor.
	Conveyor	Check for any mechanical mis-alignment or improper adjustment. Also check for worn bearings. The Installation and Operations Manual shows proper conveyor belt adjustment. A conveyor belt that is over tightened will cause excessive bearing wear and sometimes, irregular speed.
Conveyor speed varying	Power Supply	Check power supply at the DC control board for the 120 VAC at board terminals L1 and L2. If voltage is not present, check main circuit breakers
	DC Gearmotor	If the DC control board is steady, then the problem may be the motor or gearbox: Check the brushes in the motor for excessive arcing and/or unusual wear. Check the motor and gearbox from instruction located on page 20 under "possible cause" listing "Conveyor gear motor".
	Magnet	Check to insure that the magnet cemented to shaft of conveyor drive motor) has not been damaged, or come loose from motor shaft. Replace as needed.
	Hall Effect Sensor	Check for any physical damage to Hall Effect Sensor (mounted on conveyor stepper drive motor. Check all wiring and connections for damage. Check all connections for tightness or proper location and check all wiring for visible damage. Replace as needed.

REMOVAL INSTALLATION & ADJUSTMENTS

IMPINGER ADVANTAGE SERIES

CAUTION!

BEFORE REMOVING OR INSTALLING ANY COMPONENT IN THE IMPINGER OVEN BE SURE TO DISCONNECT ELECTRICAL POWER AND GAS SUPPLY

MOTOR, MAIN FAN

1. Shut off power at main breaker.
2. Remove louvered motor cover from back of oven.
3. Remove wire-way by taking out the (5) five hex screws.
4. Disconnect wiring from motor.
5. Remove the twelve (12) hex head bolts from the oven back and slide back straight out of the oven.
6. Remove two (2) bolts from fan hub and remove fan from motor shaft.
NOTE: Measure distance from fan blade to rear wall assembly before removal to aid in reassembly.
7. Remove the eight (8) hex head bolts from the motor mount and slide the motor assembly out of the oven back.
8. Remove motor by taking off motor clamp and removing the four (4) mounting nuts and washers.
9. Reassemble in reverse order. When motor mount assembly is set on the oven back, align motor shaft in the center of the hole. Set fan assembly on the motor shaft.

NOTE: A. Torque specs on bolts (150 in/lb. torque)

B. It is recommended that an anti-seize compound be brushed on to the bolts around the back and motor mount bracket before assembly.

FAN, MAIN

Shut off power at main breaker.

Remove back assembly. (See MOTOR, MAIN FAN))

Reinstall and locate fan so that the bottom of the fan spider is 1 1/2" from the top of the oven back cone. (See Drawing)

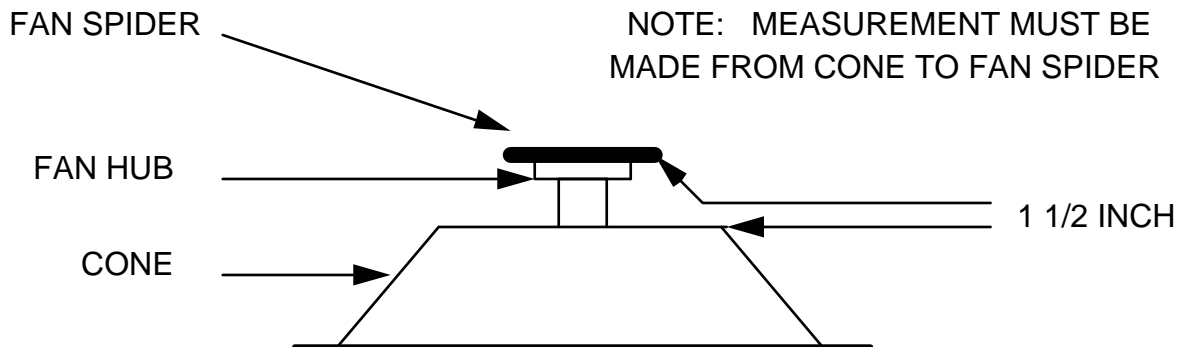

CAPACITOR, MOTOR

1. Shut off power at main breaker.
2. Remove motor cover from back of oven.
3. Discharge capacitor.
4. Remove and replace.

RELAY, D.P.S.T.

1. Shut off power at main breaker.
2. Remove control panel top and front cover.
3. Remove cover from relay box.
4. Disconnect all wires and mark for replacement.
5. Remove relay by removing two (2) mounting screws.
6. Reassemble in reverse order.

COOLING FAN, CONTROL BOX

1. Shut off power at main breaker.
2. Remove control panel top and front cover.
3. Remove four (4) screws from the fan frame.
4. Disconnect cord and plug and remove fan.
5. Reassemble in reverse order.

THERMOSTAT, COOLING FAN

1. Shut off power at main breaker.
2. Remove control panel top and front cover.
3. Remove lead wires and mark for reassembly.
4. Remove two (2) screws and remove thermostat.
5. Reassemble in reverse order.

MERCURY CONTACTOR

1. Shut off power at main breaker.
2. Remove control panel top and front cover.
3. Disconnect contactor wires and mark for reinstallation.
4. Remove screws from mounting bracket and replace contactor.
NOTE: Be sure contactor is not mounted upside down as this will cause a constant on condition.
5. Reassemble in reverse order.

HEATING ELEMENTS

1. Shut off power at main breaker.
2. Remove back cover.
3. Disconnect heater element wire and mark for reassembly.
4. Disconnect motor wiring and mark for reassembly.
5. Remove oven back from oven.
6. Remove fan shroud.
7. Heater element may now be unbolted and removed.
8. Check heater elements to be sure they are the proper voltage replacement.
9. Reassemble in reverse order.
NOTE: Be sure the heating element connections are tight.

BURNER BLOWER MOTOR - REPLACEMENT

1. Shut off power at main breaker.
2. Remove control panel top and front cover.
3. Unplug motor connector.
4. Remove three (3) screws from blower tube at burner housing.
5. Remove air shutter assembly from old motor for installation on new motor assembly.
6. Reassemble in reverse order and check system operation.

NOTE: Check air shutter adjustment and adjust if necessary. Set air shutter at approx. 1/4" and adjust to get a blue flame with an occasional tip of yellow under high flame. A view port in the burner assembly should be used to observe flame.

BLOWER WHEEL, BURNER

This is part of the burner blower motor assembly.

TO REMOVE THE BLOWER WHEEL FOR PERIODIC CLEANING:

1. Shut off power at main breaker.
2. Remove control panel top and front cover.
3. Remove air shutter held by 3 screws.
4. Loosen set screws on blower wheel hub and pull straight out.
5. Reassemble in reverse order.

NOTE: There is no critical placement of the blower wheel on the motor shaft. Just back as far as it will go and then spin the blower to be sure it is not rubbing.

BURNER CONTROL - HONEYWELL - REPLACEMENT

1. Remove control panel top and front cover.
2. Remove wires from control, note wire numbers and location for reassembly.
3. Remove Two (2) screws from control. Shut off power at main breaker. and replace.
4. Reassemble in reverse order and check system operation.

BURNER ASSEMBLY

1. Shut off power at main breaker.
2. Shut off gas supply.
3. Remove control panel top and front panel.
4. Remove gas control valve (See "GAS CONTROL VALVE")
5. Disconnect pilot tube.
6. Remove solenoid valve. (See "SOLENOID VALVE")
7. Remove four (4) screws that secure the burner backing plate.
8. Remove burner assembly from housing, the main and pilot orifice, flame target, pilot shield (main and extension), burner ignitor can now be changed or serviced as needed.
9. Reassemble in reverse order.

GAS CONTROL VALVE

1. Shut off power at main breaker.
 2. Shut off gas supply.
 3. Remove control panel top and front cover.
 4. Disconnect the gas piping from the back of the unit.
 5. Remove the four (4) screws from the incoming nipple mounting bracket.
 6. Remove incoming nipple.
 7. Remove pilot tube assembly from control valve.
 8. Disconnect pipe union just above solenoid valve.
 9. Disconnect wiring from control valve making note of wire numbers and location. Remove piping from old valve for installation on new valve.
 10. Reassemble in reverse order - after assembly is complete, be sure to check manifold pressure (3.5" W.C. NAT GAS 10" W.C. LP) and adjust if necessary. (See Section "MANIFOLD PRESSURE - ADJUSTMENT")
- NOTE:** Check all gas line fittings for leaks after installation.

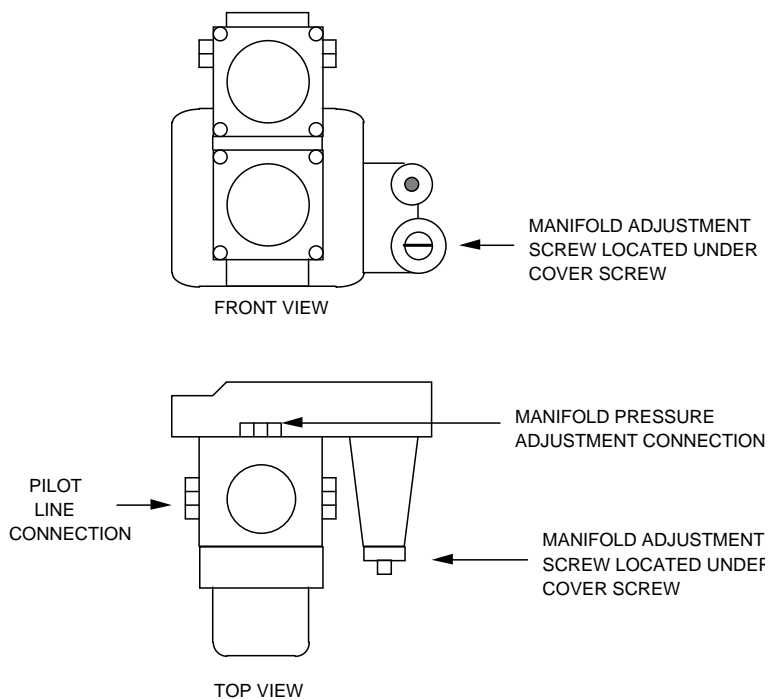

MANIFOLD PRESSURE - ADJUSTMENT

1. Remove control panel top and front cover.
2. WITH ELECTRIC POWER AND GAS OFF: remove the outlet pressure tap plug from the gas control valve and install the adapter fitting and manometer.
3. Turn on electric power and gas and start-up oven.
4. With oven at full fire, manifold pressure should be (3.5" W.C. NAT/ 10" W.C. LP)
If adjustment is needed, remove cover screw from valve body and adjust by turning regulator screw. (C.W. to increase, C.C.W. to decrease).
5. Turn off electric power and gas, replace cover screw, remove manometer and adapter; replace pressure tap plug.
6. Check pressure tap for gas leaks before closing panel.
7. Close control panel and check system operation.

SOLENOID VALVE

1. Shut off power at main breaker.
2. Shut off gas supply.
3. Remove control panel top and front cover.
4. Remove gas control valve (See "GAS CONTROL VALVE")
5. Disconnect wires from solenoid valve.
6. Remove two (2) hex nuts that hold main orifice bracket in place.
7. Remove solenoid valve assembly.
8. Remove piping from solenoid valve.
9. Reassemble in reverse order.
10. Check all fittings for leaks.

ELECTRONIC TEMPERATURE CONTROL - REPLACEMENT

1. Shut off power at main breaker.
2. Remove control panel top and front cover.
3. Remove one screw from control knob guard and move guard to one side.
4. Remove knob and lock nut on control pot. shaft and push out.
5. Remove six (6) wires from temperature control. Note wire numbers and location.
6. Reassemble in reverse order.

NOTE: All electronic temperature controls are preset and calibrated at the factory and no field adjustment is required other than aligning the temperature control knob to the scale on front panel. Place a temperature sensor in the center of the oven between top two middle fingers and set temperature control to 500°F, allow temperature to stabilize (approx. 30 min.) and adjust knob to actual temperature.

BURNER IGNITOR

1. Shut off power at main breaker.
 2. Remove control panel top and front cover.
 3. Remove burner assembly. (SEE "BURNER ASSY.")
 4. Remove pilot shield and pilot shield extension.
 5. Remove burner igniter.
 6. Reassemble in reverse order (spark gap approx. .100 in. 2.5 mm)
- NOTE:** Be sure to reconnect burner igniter cable to ignition control.

THERMOCOUPLE - REPLACEMENT

1. Shut off power at main breaker.
 2. Remove control panel top and front cover.
 3. Slide thermocouple out of oven chamber.
- NOTE:** Remove conveyor and bottom fingers to aid in removal and installation of thermocouple.
4. Remove two (2) wires from temperature control. Make note of wire numbers or color and location for reinstallation.
 5. Reassemble in reverse order making sure the metal end on the thermocouple is securely held in the wire form in the oven chamber.

THERMOCOUPLE MEASUREMENT CHART:

When two wires composed of dissimilar metals are joined together and one of the ends is heated, a continuous current flow is generated. We use an iron constant (Type J) thermocouple. The iron wire increases the number of dissimilar junctions in the circuit.

It is possible to check a thermocouple with a properly calibrated D.C. millivolt meter. At 32°F, the millivolt reading should be 0.00. Inserting the thermocouple into an ice bath can check this.

The millivolt reading at 72°F should be 1.134.

When using the following chart, the temperature at the terminal connections must be noted. This temperature is called the Junction Temperature.

The following chart lists the thermocouple millivolt readings from 200°F to 600°F.

The junction temperature is the ambient air temperature where the thermocouple fastens to the electronic temperature control.

		O	V	E	N	T	E	M	P			
		200°F	250°F	300°F	325°F	350°F	400°F	425°F	450°F	500°F	550°F	600°F
J	90°F	3.26	4.77	6.30	7.06	7.83	9.37	10.14	10.91	12.46	14.00	15.53
	88°F	3.32	4.83	6.36	7.12	7.89	9.43	10.20	10.97	12.51	14.05	15.59
	86°F	3.37	4.88	6.41	7.17	7.94	9.49	10.26	11.03	12.57	14.11	15.65
	84°F	3.43	4.94	6.47	7.23	8.00	9.54	10.31	11.09	12.63	14.19	15.71
	82°F	3.49	5.00	6.53	7.29	8.06	9.60	10.37	11.14	12.69	14.23	15.76
	80°F	3.55	5.06	6.59	7.35	8.12	9.66	10.43	11.20	12.74	14.28	15.82
	78°F	3.60	5.11	6.64	7.40	8.17	9.72	10.49	11.26	12.80	14.34	15.86
	76°F	3.66	5.17	6.70	7.46	8.23	9.77	10.55	11.32	12.86	14.40	15.94
	75°F	3.69	5.20	6.73	7.49	8.26	9.80	10.57	11.35	12.89	14.43	15.97
	74°F	3.72	5.23	6.76	7.52	8.29	9.83	10.60	11.37	12.92	14.46	15.99
72°F	3.78	5.29	6.82	7.58	8.35	9.89	10.66	11.43	12.97	14.51	16.05	
T	70°F	3.83	5.34	6.87	7.63	8.40	9.95	10.72	11.49	13.03	14.57	16.11
	68°F	3.89	5.40	6.93	7.69	8.46	10.00	10.78	11.55	13.09	14.63	16.17
	66°F	3.95	5.46	6.99	7.75	8.52	10.06	10.83	11.61	13.15	14.69	16.23
	64°F	4.01	5.52	7.05	7.81	8.58	10.12	10.89	11.66	13.20	14.74	16.28
M	62°F	4.06	5.57	7.10	7.86	8.63	10.18	10.95	11.72	13.26	14.80	16.34
	60°F	4.12	5.63	7.16	7.92	8.69	10.24	11.01	11.78	13.32	14.86	16.40

BURNER CONTROL TRANSFORMER -REPLACEMENT

1. Shut power off at main breaker.
2. Remove control panel top and front cover.
3. Remove two (2) wires on primary side, note color and location.
4. Remove two (2) wires on secondary side, note color and location.
5. Remove two (2) screws from transformer base and replace assembly.
6. Reinstall in reverse order and check system operation.

HEAT LIGHT

1. Shut off power at main breaker.
2. Remove control panel top and front panel.
3. Remove the two wires from burner light, note number and location.
4. Grasp body of light assembly and slide sideways to remove.
5. Reassemble in reverse order and check.

CONVEYOR CONTROL POTENTIOMETER (10K OHM) - REPLACEMENT

1. Shut power off at main breaker.
2. Remove control panel top and front cover.
3. Remove the access cover.
4. Loosen two (2) allen screws and remove knob by sliding off shaft.
5. Remove mounting nut from potentiometer shaft and push out.
6. Unplug wire connector from conveyor control board.
7. Reassemble in reverse order and check system operation. Recalibrate knob as needed.

CONVEYOR CONTROL BOARD ASSEMBLY - REPLACEMENT

1. Shut power off at main breaker.
2. Remove control panel top and front cover.
3. Remove two (2) top screws and loosen one (1) bottom screw from control assembly.
4. Disconnect wiring (Push on connectors) from control board, note proper location of connectors for reinstallation and exchange boards on the mounting bracket before reinstallation.
5. Reassemble in reverse order and check system operation.

NOTE: Control boards are calibrated at the factory and no board adjustment is required.

CONVEYOR DRIVE MOTOR - REPLACEMENT

1. Shut power off at main breaker.
2. Remove control panel top and front cover.
3. Loosen set screw on conveyor drive sprocket and slide sprocket off shaft.
4. Disconnect motor plug and wiring for hall effect sensor board.
5. Remove four (4) screws from motor frame, on control box side, and remove motor assembly.
6. Remove sensor board. * **See Note**
7. Reassemble in reverse order making sure to align chain sprockets and adjust motor for proper chain tension (1/2" SAG).

NOTE: When replacing the drive motor it will be necessary to also install a new magnet on the shaft up against the shoulder and cement in place.

REVERSING CONVEYOR DIRECTION

All ovens leaving our plant are wired to operate conveyors from left to right. To reverse conveyor direction, use the following procedure.

1. Shut off power at main breaker.
2. Remove control panel top.
3. Remove cover from relay box.
4. Reverse wires fastened to terminals A+ and A- on conveyor control board
5. Reassemble in reverse order.

HALL EFFECT SENSOR - REPLACEMENT

1. Shut off power at main breaker.
2. Remove control box cover.
3. Remove three- (3) wire connector from hall effect sensor board.
4. Remove two (2) screws from conveyor drive motor.
5. Remove sensor board from mounting bracket.
6. Reassemble in reverse order.
7. Reinstall plug on hall effect sensor board.
8. Replace control box covers and check system operation.

CIRCUIT BREAKER - REPLACEMENT

1. Shut off power at main breaker.
 2. Remove control panel top and front panel.
 3. Disconnect two (2) wires from circuit breaker.
 4. Remove knurled mounting nut and push out.
 5. Reassemble in reverse order.
- NOTE:** Be sure to reset breaker before operating.

MAIN ORIFICE - REPLACEMENT

1. Shut off power at main breaker.
 2. Remove control panel top and front panel.
 3. Remove gas valve assy.
 4. Remove two (2) nuts from burner orifice bracket.
 5. Disconnect pipe union.
 6. Remove assembly and replace main orifice.
 7. Reassemble in reverse order and check system operation.
- NOTE:** Check all gas line fittings for leaks.

PILOT ORIFICE - BURNER

1. Shut off power at main breaker.
 2. Shut off gas supply.
 3. Remove burner assembly (See "Burner Assembly").
 4. Remove pilot line from pilot orifice.
 5. Remove pilot orifice from burner igniter.
 6. Reassemble in reverse order.
- NOTE:** Check all gas line fittings for leaks.

ON-OFF SWITCH - REPLACEMENT

1. Shut off power at main breaker.
 2. Remove control box cover.
 3. Remove the access cover.
 4. Depress spring clips on side of switch and push out.
 5. Remove wires from back of switch, note wire number and location.
 6. Reassemble in reverse order and check system operation.
- NOTE:** Make sure switch housing is fully seated in control box housing.

THE FOLLOWING ITEMS ARE USED IN THE MODEL 1456, 1457, 1474, 1475, 1476 IMPINGER OVENS

AIR PRESSURE SWITCHES - REPLACEMENT AND ADJUSTMENT

1. Remove control panel top.
2. Disconnect wires from switch making note of wire number and location for reinstallation.
3. Remove air tube from switch assembly.
4. Remove switch from wire hanger.
5. Install new switch in reverse order, make sure air tube is not blocked or miss-aligned. Adjust as needed.

To adjust the air pressure switch, remove snap on cover on the side of the switch to expose adjusting screw. To increase sensitivity, turn screw counter clockwise; to decrease sensitivity, turn screw clockwise. Check for proper line voltage switching from N.C. to N.O. as the air pressure switch closes.

GAS VALVE - REPLACEMENT AND ADJUSTMENTS

1. Remove control panel top and front cover.
2. Disconnect the gas piping from the back of the unit.
3. Remove the four(4) screws from the incoming nipple mounting bracket.
4. Remove incoming nipple.
5. Disconnect two (2) plugs, (1) 3 prong and (1) 4 prong - Note location.
6. Disconnect pipe union just above gas valve and remove assembly.
7. Reassemble in reverse order (check all pipe fittings for leaks). After assembled, check for proper adjustment of gas pressure switch, 8.8 on dial for natural gas, 23 for L.P. Gas and 4.5 for town gas.
8. Check and adjust manifold pressure. remove pressure tap located in gas piping above the gas valve prior to the burner orifice and install manometer. Adjustment screw is located on the front of the valve, remove plastic cap and adjust as needed: 3.5" WC for Natural Gas and 10" WC for L.P.
9. Check gas filter by removing cover plate (located on either side of valve). Remove four (4) screws and slide filter out of valve housing and inspect. Reassemble in reverse order and check
10. for leaks around the cover.

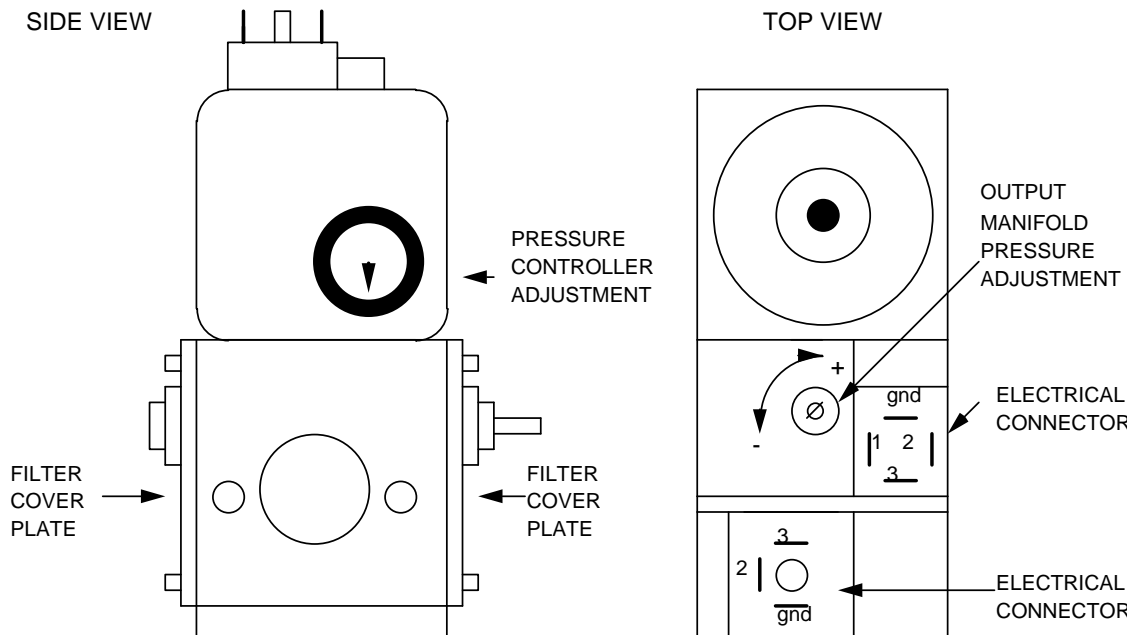

IGNITION CONTROL - REPLACEMENT

1. Remove control panel top and front cover.
2. Depress two (2) locking clips on front cover of relay.
3. Remove control portion of relay by pulling straight out (rocking motion).
4. Remove wires from plug-in terminal strip, note wire numbers and location.
5. Remove two (2) screws from mounting bracket and remove.
6. Reassemble in reverse order. Check system operation.

HIGH LIMIT THERMOSTAT - REPLACEMENT

1. Remove control panel top and front cover.
2. Remove conveyor and fingers.
3. Remove capillary bulb from wire form in oven chamber and pull through tube into control box.
4. Remove two (2) wires from thermostat, note wire numbers and location for reinstallation.
5. Remove screws from bracket and remove thermostat.
6. Reassemble in reverse order making sure capillary tube is placed securely in the wire form.

NOTE: Depress reset button to insure thermostat is set for operation.

SPARK GENERATOR - REPLACEMENT

1. Remove control panel top and front cover.
2. Remove two (2) wires for spark generator.
3. Unplug spark lead on bottom of spark generator from ignition control.
4. Remove two (2) mounting screws and remove generator assembly.
5. Reassemble in reverse order and check system operation.

SOLENOID VALVE - REPLACEMENT

1. Remove control panel top and front cover.
2. Disconnect pipe union just above gas valve assembly.
3. Disconnect two (2) wires from solenoid, note wire number and location for reinstallation.
4. Remove four (4) nuts from main orifice burner bracket and remove assembly.
5. Replace valve and reassemble in reverse order.
6. After assembly, check all fittings for leaks and check system operation.

BURNER ALARM - REPLACEMENT

1. Remove control panel top and front cover.
2. Remove two (2) wires from alarm, note wire numbers and location.
3. Remove retainer cover from alarm and remove assembly from mounting bracket.
4. Reassemble in reverse order and check.

LIGHT (220V) - REPLACEMENT

1. Remove control panel top and front cover.
2. Remove two (2) wires from light assembly, note wire number and location.
3. Grasp body of light assembly and slide sideways to remove.
4. Reassemble in reverse order and check.

TRANSFORMER, STEP DOWN/120 VAC

1. Shut off power at main breaker.
2. Remove control compartment covers.
3. Remove wires from transformer and mark for reassembly.
4. Remove 4 mounting screws from transformer base and replace.
5. Reassemble in reverse order.

NOTE: Voltage output of the secondary is to be 120 VAC \pm 10%. Check for this output at the secondary before installing leads to the secondary. If voltage above or below is measured, recheck the position of the primary leads.

GENERAL – 1450 SERIES

LETTER	PART #	DESCRIPTION
A	369003	Door Hinge
B	369110	Access Window Assy.
C	369337	Retainer (Old Style)
	369929	Retainer (New Style)
D	369828	Handle, Spacer
E	369209	Latch & Strike
F	369310	Screw 6-32 x 3/16"
G	369308	Access Window Assy. Bottom
H	369334	Access Door Glass
J	369309	Access Window Assy. Top
K	350638	Handle
L	369311	Handle Spacer (2 Required)
M	369336	Door Latch
N	369906	Screw 8-32 x 5/8"
O	370110	Door Assy. (Solid)
P	369157	Door Assy. W/Window
Q	1534	Finger Support Assy.
R	369057	Support Bracket Pins
S	369643	Strike Assy.
T	1009	Oven Top
U	369062	Top, Control Panel
V	369140	Compression Spring
W	369903	Washer, Flat
X	369141	Conveyor Hold Down Bracket
Y	369139	Shoulder Screw
Z	369058	Baffle, Inlet and Outlet
*	369211	Thumb Screw (Not Shown)
AA	369203	Stud Wing Head
BB	369749	Chain Cover Kit (Includes AA, CC)
CC	369204	Split Ring Retainer
DD	369373	Receptacle, Snap-In
EE	369748	Bracket, Chain Cover
FF	369328	Stand, Leg
GG	369052	Adjustable Leg
HH	369030	Caster 6"
JJ	369904	Insulation Holder Assy.
KK	369053	Finger Housing
LL		Columnating Panels – See Installation Manual
MM	369055	Finger Cover
NN	369218	Crumb Pan, Internal
OO	369926	Window Frame, Bottom
PP	369925	Glass, Access Window
QQ	369927	Window Frame, Top

GENERAL - 1450 SERIES BLOW-UP

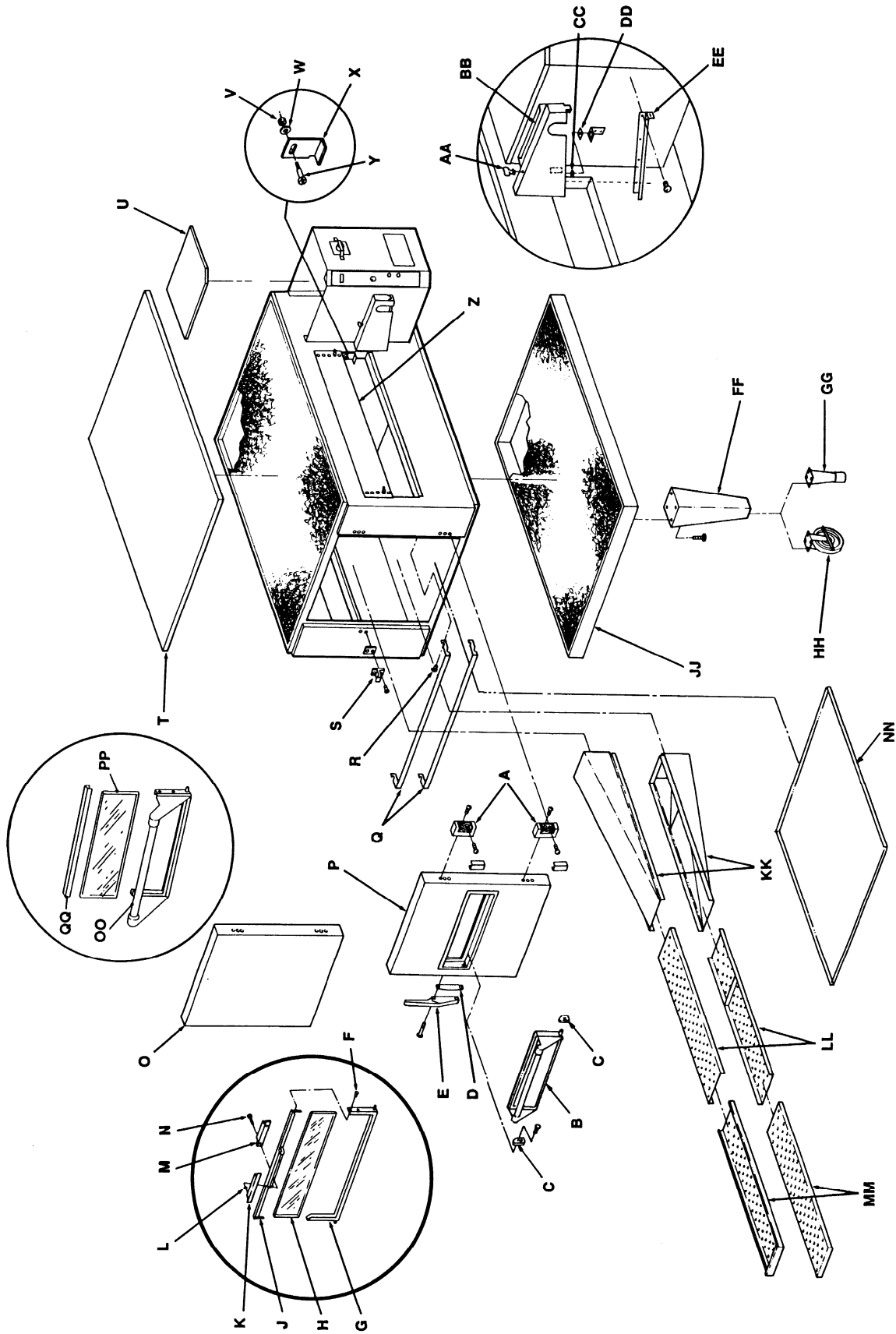

CONTROL BOX – 1450, 1451, 1480

LETTER	PART #	DESCRIPTION
A	369012	Fuse Holder
B	369014	Fuse, 10 AMP
C	369013	Fuse, 3 AMP
D	369872	Instruction Plate
E	369805	Switch, On/Off
F	369809	Conveyor Control Pot.
G	369507	Cooling Fan Thermostat
H	369154	.7 AMP Circuit Breaker
J	369523	Relay, Motor
K	369803	Control, Conveyor
L	369531	Transformer
M	369393	Ignition Control NAT/LP
N	369125	Terminal Block
O	369131	Thermocouple with Terminals
P	369366	Burner Blower Motor Kit
Q	369131	Finger Guard, Cooling Fan
R	369801	Thermostat (Temperature Control)
S	369128	Neon Pilot Light
T	350224	Lens, Yellow
U	369804	Knob, Clear Skirt
V	369202	Pilot Shield, Main
W	369144	Pilot Shield Extension
X	369263	Gas Valve (Body only) NAT/LP for 1450 & 1451
	370025	Gas Valve for 1480
Y	369334	Pilot Shut-off Valve
Z	369398	Solenoid Valve NAT/LP for 1450 & 1451
	370026	Solenoid Valve for 1480
AA	369072	Main Burner Orifice – NAT
	369099	Main Burner Orifice - LP
	370113	Main Burner Orifice - 1480
BB	369075	Flame Sensor
CC	369073	Pilot Orifice – NAT
	369100	Pilot Orifice – LP
	370114	Pilot Orifice – 1480
DD	369076	Burner Igniter
EE	369142	Flame Target
FF	369822	Magnet, 8 Pole
GG	369291	Conveyor Motor and Gear Box Assy.
HH	369158	10 Tooth Sprocket
JJ	369824	Bracket, Hall Effect
KK	369823	Hall Effect Sensor
LL	369124	Cooling Fan, Control Box
MM	369810	Hall Effect Cable
NN	370138	Face Plate, Temperature
OO	370027	Front Cover
PP	369399	Air Shutter
QQ	369400	Plate, Air Shutter

CONTROL BOX – 1450, 1451, 1480 BLOW-UP

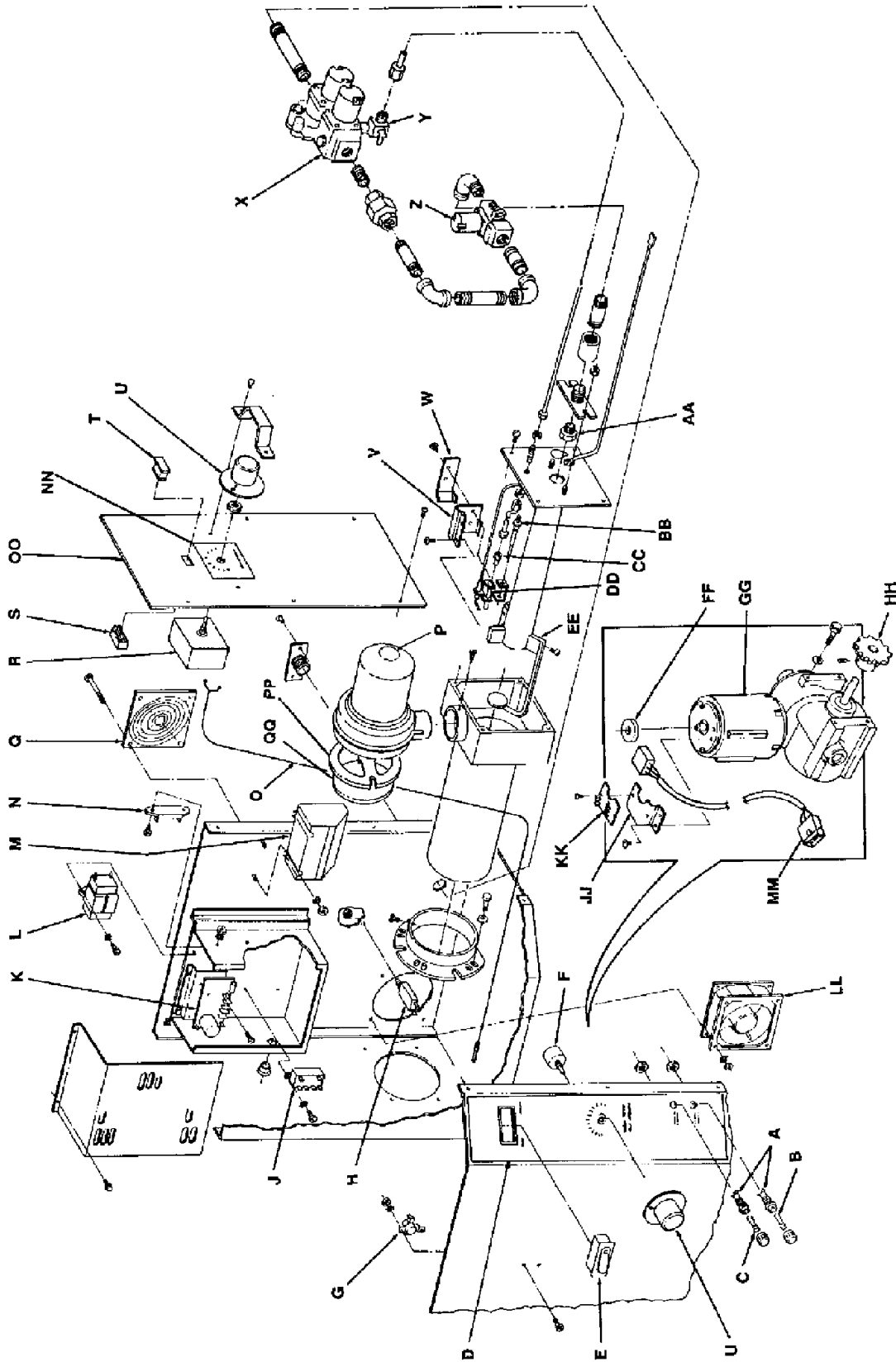

CONTROL BOX – 1452, 1453

LETTER	PART #	DESCRIPTION
A	369129	Fuse Holder
B	369166	Fuse, 10 AMP
C	369013	Fuse, 3 AMP
D	369012	Fuse Holder
E	369804	Knob, Clear Skirt
F	370139	Instruction Plate
G	369805	Switch, On/Off
H	369507	Cooling Fan Thermostat
I	369119	Fuse Holder, 60 AMP
J	369134	Fuse, 50 AMP
K	369118	Power Terminal Block
L	369120	Contact, 60 AMP
M	369803	Control, Conveyor
N	369838	Thermostat, Hi-Limit
O	370112	Box, Electric
P	353014	Supply Terminal (Ground)
Q	369801	Thermostat (Temperature Control)
R	350224	Lens, Yellow
S	369154	.7 AMP Circuit Breaker
T	369125	Terminal Block
U	369523	Relay, Motor Power
V	369368	Thermostat, Capillary
W	369158	Sprocket, 10 Tooth
X	369291	Motor and Gearbox Assy.
Y	369822	Magnet, 8 Pole
Z	369823	Hall Effect Sensor
AA	369824	Bracket, Hall Effect
BB	369331	Finger Guard, Cooling Fan
CC	369809	Conveyor Control Pot.
DD	369124	Cooling Fan, Control Box
EE	369810	Hall Effect Cable
FF	369131	Thermocouple
GG	370027	Front Cover
HH	369128	Pilot Light
JJ	370138	Face Plate, Temperature

CONTROL BOX – 1452, 1453 BLOW-UP

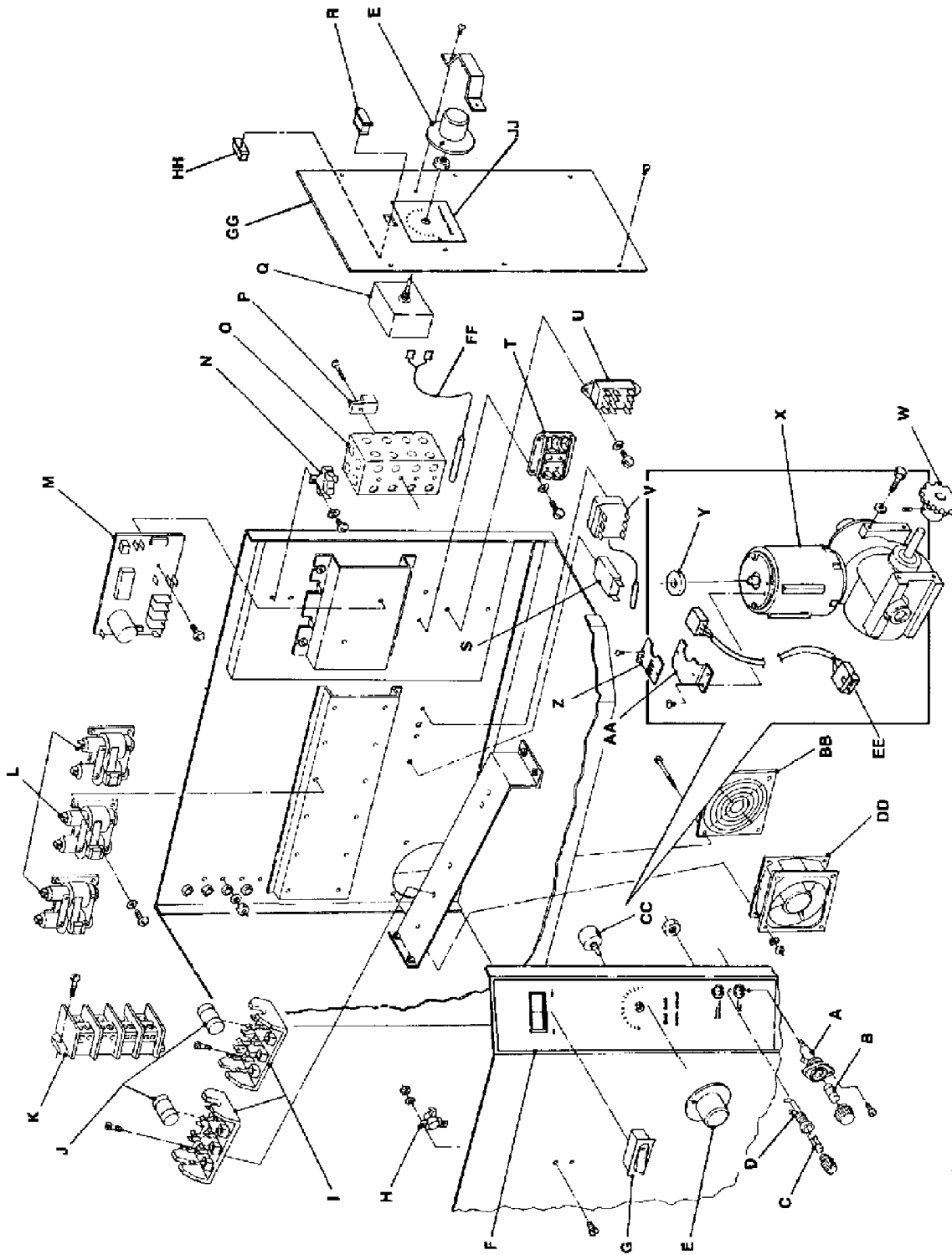

CONTOL BOX – 1454, 1455

LETTER	PART #	DESCRIPTION
A	357107	Fuse Holder
B	369014	Fuse, 10 AMP
C	369013	Fuse, 3 AMP
D	370137	Label, Front Panel
E	369804	Knob, Clear Skirt
F	369432	Switch, On/Off
G	369507	Cooling Fan Thermostat
H	369119	Fuse Holder, 60 AMP
I	369134	Fuse, 50 AMP
J	369786	Ball Chain .125 Diameter
K	369575	Air Pressure Switch
L	369576	Fitting
M	369578	Hose
N	369302	Contactora, 50 AMP
O	354258	Transformer
P	369803	Control, Conveyor
Q	369838	Thermostat, Hi-Limit
R	369801	Thermostat (Temperature Control)
S	350224	Lens, Yellow
T	369154	.7 Amp Circuit Breaker
U	369125	Terminal Block
V	369523	Relay, Motor Power
W	369368	Thermostat, Capillary
X	369158	Sprocket, 10 Tooth
Y	369291	Motor and Gearbox Assy.
Z	369822	Magnet, 8 Pole
AA	369823	Hall Effect Sensor
BB	369824	Bracket, Hall Effect
CC	369331	Finger Guard, Cooling Fan
DD	369809	Conveyor Control Pot.
EE	369378	Cooling Fan, Control Box
FF	370062	Junction Box
GG	370117	Terminal Block, 5 Pole
HH	370063	Junction Box Cover
JJ	369131	Thermocouple
KK	369128	Pilot Light
LL	370027	Front Cover Assy
MM	370138	Face Plate, Temperature

CONTROL BOX – 1454, 1455 BLOW-UP

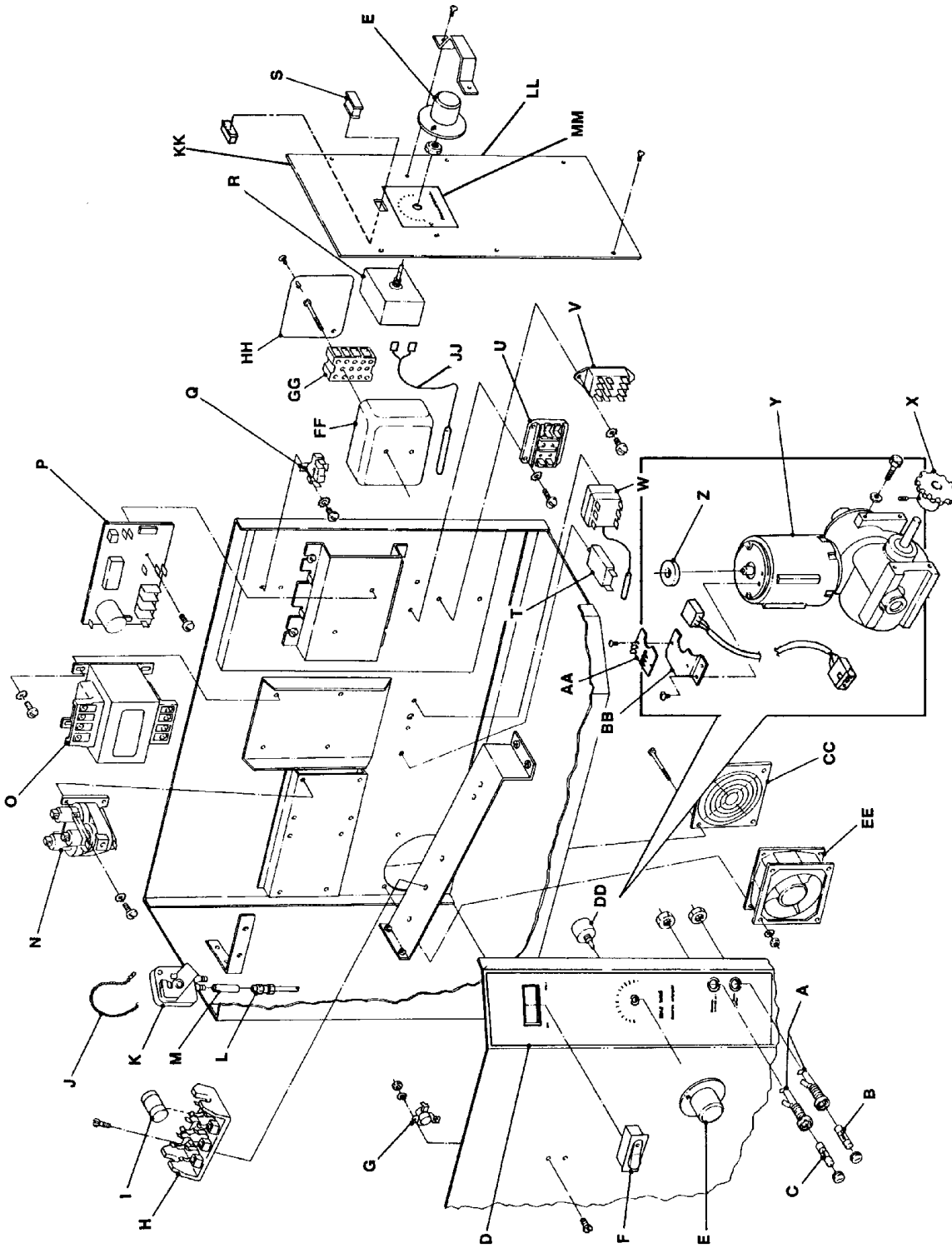

CONTROL BOX – 1456, 1457, 1474, 1475, 1476

LETTER	PART #	DESCRIPTION
A	369378	Cooling Fan
B	369809	Conveyor Control Pot.
C	357107	Fuse Holder
D	369014	Fuse, 10 Amp
E	369013	Fuse, 3 Amp
F	369804	Knob, Clear Skirt
G	369432	Switch, On/Off
H	369507	Cooling Fan Thermostat
I	369575	Air Pressure Switch
J	369786	Chain
K	369543	Transformer
L	369422	Relay
M	369125	Terminal Block
N	369574	Spark Generator
O	369579	Solid State Alarm
P	369331	Finger Guard
Q	369801	Thermostat (Temperature Control)
R	369128	Pilot Light
S	350224	Lens, Yellow
T	369578	Hose
U	369580	Gas Valve, Multi Block
V	369570	Connector, 3 Pole
W	369571	Connector, 4 Pole
X	369398	Solenoid Valve – 1456, 1457
	369889	Solenoid Valve – 1474, 1475, 1476
Y	369702	Main Burner Orifice, NAT
	369099	Main Burner Orifice, LP
	370113	Main Burner Orifice, Town Gas
Z	369144	Pilot Shield Extension
AA	369202	Pilot Shield, Main
BB	369075	Flame Sensor
CC	369073	Pilot Orifice, NAT
	369100	Pilot Orifice, LP
	370114	Pilot Orifice, Town Gas
DD	369076	Burner Igniter
EE	369158	10 Tooth Sprocket
FF	369291	Conveyor Motor & Gearbox Assy.
GG	369822	Magnet, 8 Pole
HH	369142	Flame Target
II	369824	Bracket, Hall Effect
JJ	369823	Hall Effect Sensor
KK	369771	Switch, Burner Reset
LL	369368	Thermostat, Hi-Limit
MM	369933	Flange Burner
NN	369154	07 AMP Circuit Breaker
OO	369523	Motor Relay
PP	369803	Control, Conveyor
QQ	369573	Ignition control
RR	369589	Blower Motor
SS	369872	Control Facia
TT	369131	Thermocouple

CONTROL BOX – 1456, 1457, 1474, 1475, 1476 BLOW-UP

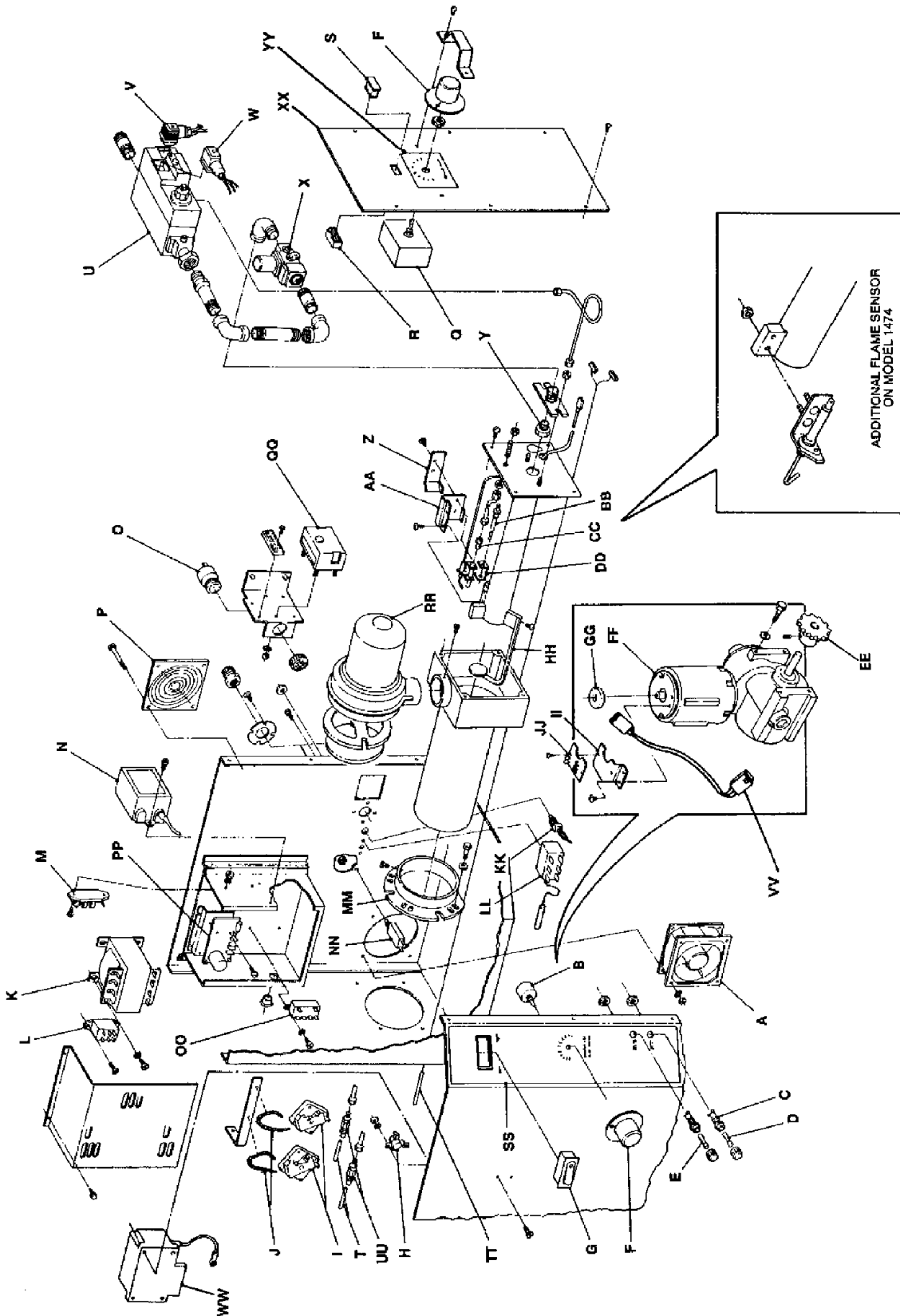

OVEN BACK, GAS – ELECTRIC

LETTER	PART #	DESCRIPTION
A	369808	Cover, Motor (Gas Ovens)
	370140	Cover, Motor (Electric Ovens)
B	369800	Motor, Main Fan (60 Hz)
	369214	Motor, Main Fan (50 Hz)
C	369033	Motor Clamp
D	369215	Motor Support Assy.
E	369192	Capacitor 7.5 MFD
F	369306	Oven Back Assy – Gas
G	369646	Stand Off
H	369647	Inlet Panel
J	369213	Fan, Main
K	369547	Wire Form Thermostat Bulb
L	369307	Oven Back Assy. – Electric
M	369287	Heating Element, 208V
	369315	Heating Element, 220V
	369122	Heating Element, 240V

OVEN BACK, GAS – ELECTRIC BLOW-UP

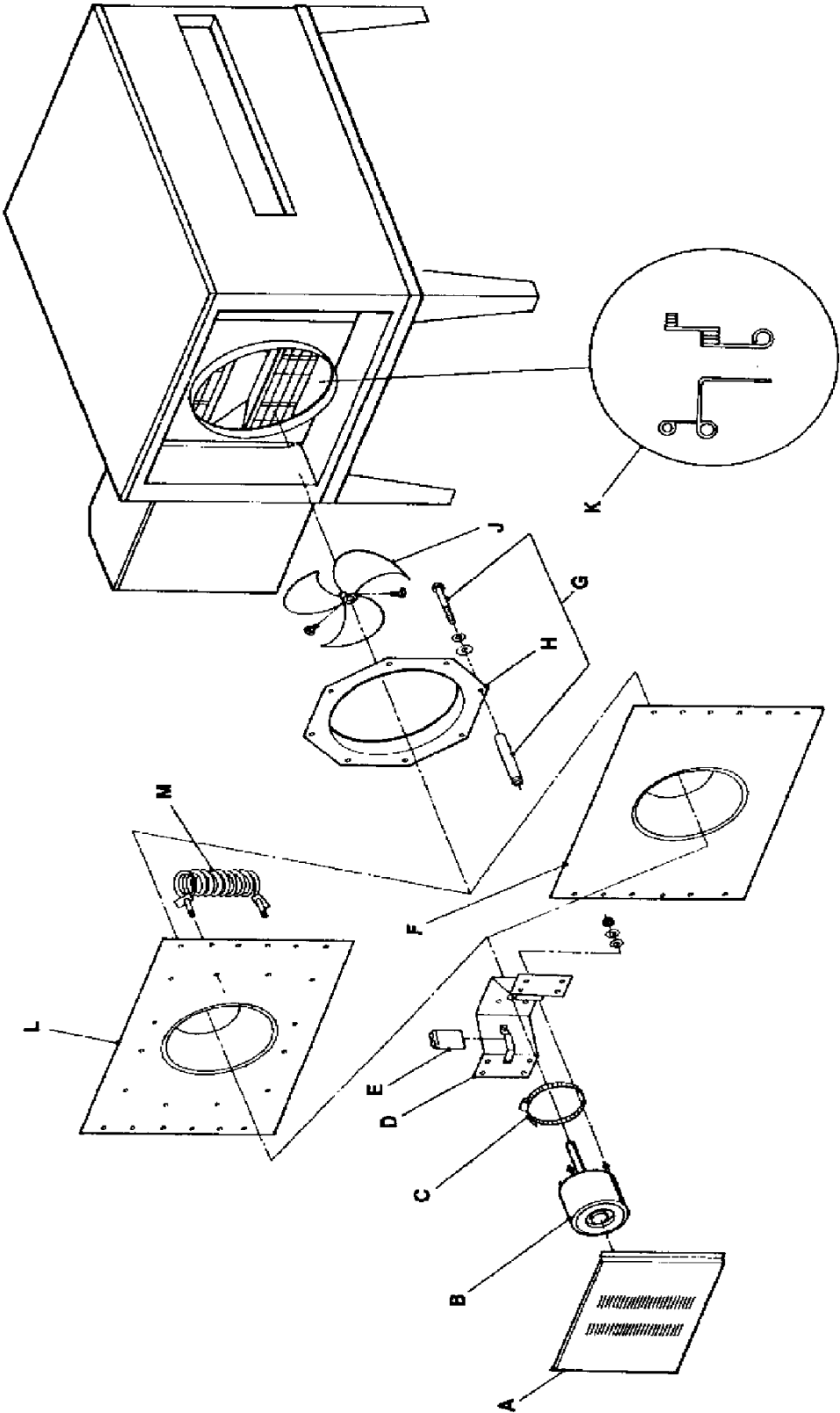

CONVEYOR – 1450 SERIES

LETTER	PART #	DESCRIPTION
	369830	Complete Conveyor
A	369816	Conveyor Belting
	370092	Conveyor Belting, 1 Foot Section
B	369825	Retaining Ring
C	369813	Conveyor Bearing Block
D	369314	Roll, Conveyor, Notched
E	369812	Conveyor Idler Shaft
F	369160	Conveyor Pan Stop
G	369814	Connecting Link
H	369811	Conveyor Drive Shaft
J	369161	Roller Chain Sprocket
K	369806	Crumb Pan
L	370050	Conveyor Frame
M	369162	Drive Chain

CONVEYOR 1450 SERIES BLOW-UP

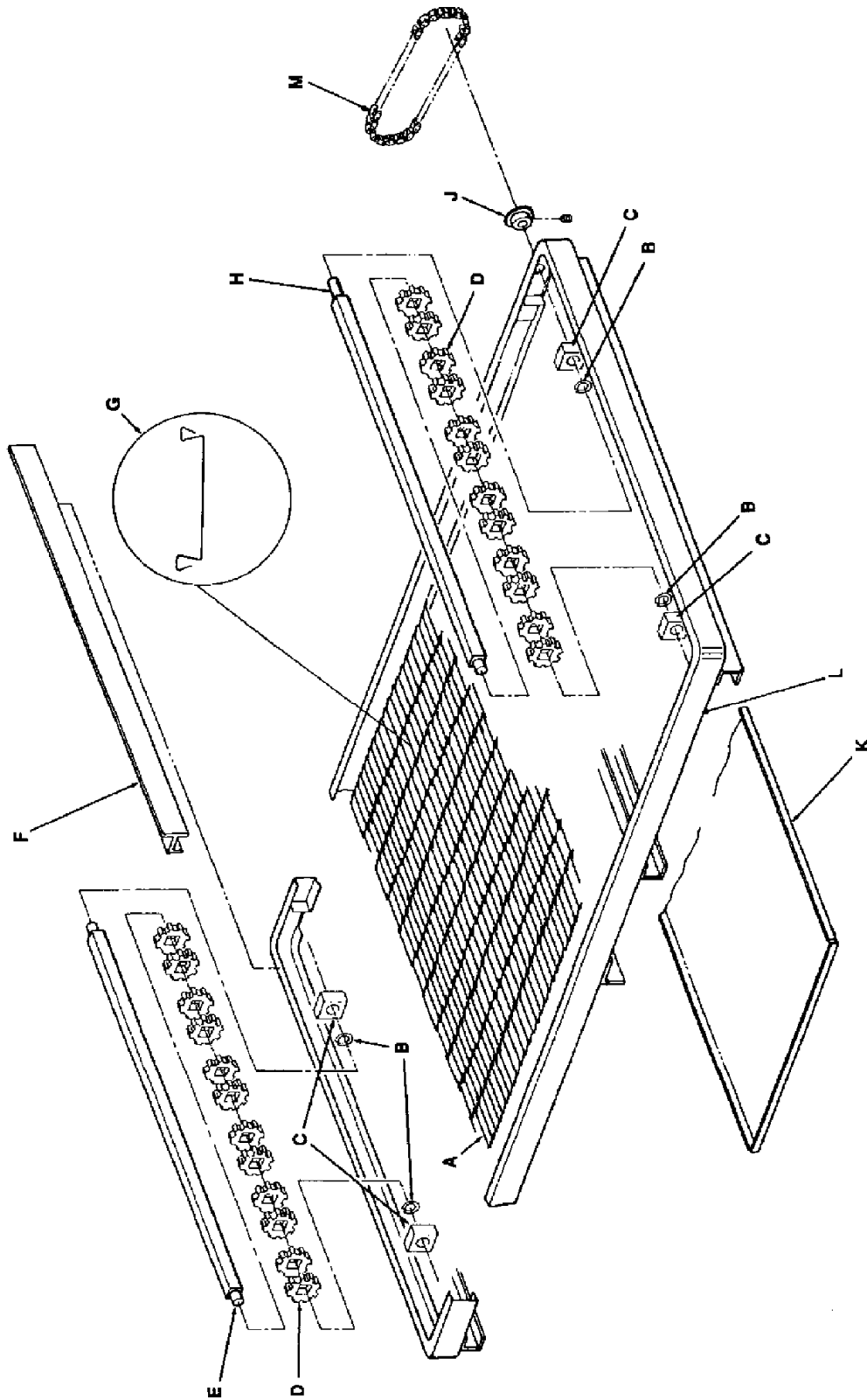



Lincoln Foodservice Products, LLC
1111 North Hadley Road
Fort Wayne, Indiana 46804
United States of America

Telephone: (260) 459-8200
U.S. Facsimile: (888) 790-8193
Int'l Facsimile: (260) 436-0735

Technical Service Hotline: (800) 678-9511

www.lincolnfp.com

