



# PARTS & SERVICE MANUAL

## Impinger Low Profile – Advantage Digital Series

Domestic Models

---

### MODELS:

Please note that the model numbering system changed March 2007. The chart below shows the old model numbering system and its matching new model number.

Old Model Number	→	New Model Number
1600-000-A	→	1600-00z-U-Kxxxx
1601-000-A	→	1601-00z-U-Kxxxx

P/N: L371150  
REV: 10.22.09

Lincoln Foodservice Products, LLC  
1111 North Hadley Road  
Fort Wayne, Indiana 46804  
Telephone: 260.459.8200  
Fax: 888.790.8193  
Technical Support: 800.678.9511  
lincolnfp.com

**SEQUENCE OF OPERATIONS / 1600-000-A, 1601-000-A  
SERIAL NUMBERS L28563 and ABOVE  
(with push button control)**

MODEL 1600-000-A / 120 VAC / 60 HZ / NATURAL GAS  
MODEL 1601-000-A / 120 VAC / 60 HZ / L.P. GAS

POWER SUPPLY	Electrical power to be supplied to the oven by a three conductor cordset. Voltage from the black conductor to the white conductor to be 120 VAC. White conductor is Neutral. Green conductor is Ground.
CONTROL BOX AUTO COOL DOWN	When the temperature in either one of the Control Boxes reaches 120° F ± 3° F (49° C ± 1.7° C), the Cooling Fan Thermostats will switch power to the Cooling Fans. The thermostats will interrupt the power to the Cooling Fans when temperature falls to 100° F ± 3° F (37° C ± 1.7° C).
MAIN FAN CIRCUIT	120 VAC is permanently supplied to the normally open Power Switch, both normally open Cooling Fan Thermostats, and one of the normally open contacts of the Power Relay. Closing the normally open Power Switch supplies 120 VAC through the Cooling Fan Motor Fuse, and through both normally closed control box Hi-limit Thermostats energizing the coil of the Oven Power Relay. These normally open contacts now close supplying 120 VAC through the 10 Amp Main Fan Motor Fuse to the two Main Fan Motors and the two Burner Motors. Power is also supplied to the four cooling fan motors, the Control Transformer, heat, and conveyor control systems.
BURNER CIRCUIT	Closing the Oven Power Relay supplies 120 VAC to the two burner systems. NOTE: This oven utilizes two complete burner systems. The sequence of operations is the same for each system. 120 VAC is supplied through the Centrifugal Switch of the Main Fan Motor (this switch closes when the Main Fan reaches approximately 1600 R.P.M.) through the 10 Amp Fuse, to the Ignition Control, the oven Temperature Control, and the Burner Transformer. As the Burner Blower reaches approximately 1600 R.P.M., its internal Centrifugal Switch will close, supplying 24 VAC to the Ignition Control. The Ignition Control operates on both 24 VAC and 120 VAC. When the Ignition Control is energized by 24 VAC, 120 VAC is switched to the Hot Surface Igniter for 45 seconds for Hot Surface Igniter warm up. The igniter glows red, 24 VAC is switched to the Gas Valve which opens, and ignition should occur. If ignition does not occur in 6 seconds, the control will lock out. To recycle after lockout, turn the Power Switch off for 45 seconds and then turn back on.
TEMPERATURE CONTROL	When the Centrifugal Switch of the Main Motor Fan closes, power is applied to the oven Control. The Oven Control is set to the desired temperature. The thermocouple will provide varying millivolts to the Oven Control. The Oven Control supplies 120 VAC to the Temperature Regulation Valve at intermittent intervals to maintain the desired temperature. The display on the Oven Control will indicate when the Temperature Control Valve is energized. NOTE: The display also indicates oven temperature.
CONVEYOR DRIVE	Closing the main Power Switch supplies 120 VAC through the Oven Power Relay to the Conveyor Motor and to the primary of the Control Transformer. Secondary voltage, 24 VAC, is supplied to the Oven Control. Setting the Control to the desired time outputs voltage through a Reversing Switch to the Conveyor Motor. NOTE: The conveyor system uses a Magnet and a Hall Effect Sensor to prove operation of the Conveyor Motor. If the Conveyor Motor is not running, "BELT JAM" is indicated on the display.



## TROUBLESHOOTING GUIDE GAS OVENS

MODEL 1600-000-A	NATURAL GAS	120 VAC.	60 HZ.	1 PHASE
MODEL 1601-000-A	LP GAS	120 VAC.	60 HZ.	1 PHASE

NOTE: When checking components on left side of oven, be sure to check for proper connections in power connector, (marked P.C. on schematic diagram) located inside motor cover.

SYMPTOM POSSIBLE	CAUSE	EVALUATION
Oven fan will not run	Incoming power supply	Check circuit breakers, reset if required. Check power plug to be sure it is firmly in receptacle. Measure the incoming voltage. Call power co. if needed.
	Power switch	Check continuity between switch terminals. Replace switch as needed.
	Fuse, 10 Amp	Check, replace if necessary.
	Fuse holder	Check, replace if necessary.
	Fuse, 3 Amp	Check, replace if necessary.
	Fuse holder	Check, replace if necessary.
Hi-limit	thermostat(s), control box	Check for voltage on both sides of the switch. Terminals are normally closed. If open, reset and test oven for proper operation. If thermostat will not hold, and control box temperature is not exceeding 140°F (60°C), replace thermostat
	Relay, oven power	Check for 120 VAC to the relay coil. If voltage is not present, Trace wiring back to the hi-limit thermostat. If voltage is present, check to insure contacts are closing. Check for 120 VAC supplied to terminal #2 of the relay. If voltage is not present at terminal #2, trace wiring back to the 10 Amp fuse. Replace relay as needed.
	Motor, main fan	Check for opens, shorts or grounds. WITH POWER OFF: turn fan blade to check for locked rotor.
	Capacitor	Check for shorts or grounds. WARNING: Capacitor has a stored charge, discharge before testing.
No control box cooling	Incoming power	Check circuit breakers, reset if required. Check power plug to be sure it is firmly in receptacle. Call power co. if needed.
	Power switch	Check continuity between switch terminals. Replace switch as needed.
	Fuse, 3 Amp	Check, replace if necessary.
	Fuse holder	Check, replace if necessary.
Hi-limit	thermostat(s), control box	Check for voltage on both sides of the switch. Terminals are normally closed. If open, reset and test oven for proper operation. If thermostat will not hold and control box temperature is not exceeding 140°F (60°C), replace thermostat.
	Cooling fan(s)	120 VAC should now be at the fan motor. If voltage is not present, trace wiring back to hi-limit thermostat. Check motor for opens, shorts or grounds. WITH POWER OFF: Check for locked rotor.
No automatic control box cooling	Incoming power supply	Check circuit breakers, reset if required. Check power plug to be sure it is firmly in receptacle. Call power co. if required.
Cooling fan thermostat(s)	ng fan thermostat(s)	Check the cooling fan thermostat. (thermostat closes at 120°F and opens at 100°F) With the cooling fan thermostat preheated, check for continuity. If switch is open, replace thermostat.
	Fuse, 3 Amp	Check, replace if necessary.
	Fuse holder	Check, replace if necessary.
Hi-limit	thermostat(s) control box	Check for voltage on both sides of switch. Terminals are normally closed. If open, reset and test oven for proper operation. If thermostat will not hold, and control box

		temperature is not exceeding 140° F (60°C), replace thermostat.
	Cooling fan(s)	120 VAC should be at the motor. If voltage is not present, trace wiring back to hi-limit thermostat. Check motor for opens, shorts or grounds. WITH POWER OFF: Check for locked rotor.
Oven will not heat	Gas supply	Check for adequate gas supply and closed manual gas valves. Also check flexible gas line connection for any damage.
	Main fan	If not operating, refer to "Oven fan will not run".
NOTE: These ovens utilize 2 complete burner/temperature control systems. Each system will follow the same troubleshooting sequence.		
	Oven power relay	Check for 120 VAC to the relay coil. If voltage is not present, trace wiring back to the control box hi-limit. If voltage is present, check to insure contacts are closing. Check for 120 VAC supplied to terminal #6 of the relay. If voltage is not present at terminal #6, trace wiring back to the power source. Replace relay as needed.
	Centrifugal switch of main fan motor	Check for 120 VAC supplied to the centrifugal switch. If no voltage is present, trace wiring back to the oven power relay. If voltage is supplied to the centrifugal switch, and the motor is running, but there is no voltage out of the centrifugal switch, replace the main fan motor. NOTE: See schematic diagram for proper wire numbers on motors.
	Fuse, burner 10Amp	Check, replace if necessary.
	Fuse holder	Check, replace if necessary.
	Burner blower motor	Check for 120 VAC supplied to burner blower motor. If voltage is not present, trace wiring back to oven power relay. If voltage is present and motor does not run, replace burner blower motor. WITH POWER OFF: Check for locked rotor.
	Burner transformer	Check for 120 VAC to the primary of the 24 VAC burner transformer. If voltage is not present, trace wiring back to the burner fuse. If voltage is present, check for 24 VAC at the transformer secondary. If no secondary voltage is present, replace the transformer.
	Centrifugal switch of burner blower motor	Check for 24 VAC to the centrifugal switch of burner blower motor (see schematic diagram for proper wire numbers). If no voltage is present, trace wiring back to the burner transformer. If voltage is present, check for 24 VAC at the output of the centrifugal switch. If there is no output, and the burner blower motor is running, replace the burner blower motor.
	Ignition control	Check for 24 VAC supply to the ignition control at terminals 24V and 24Vgnd. If voltage is not present, trace wiring back to the centrifugal switch. Check for 120 VAC supply to the ignition control at terminals L1 and L2. If no voltage is present, trace wiring back to burner fuse. If the above checks are okay, proceed. The ignition control should switch 120 VAC to the hot surface igniter, across the two terminals marked HSI. If no voltage is present, replace the ignition control.
	Hot surface igniter (located inside burner assy.	If 120 VAC is present at HSI terminals, visually check to see that the hot surface igniter is heating (igniter may be viewed through port in the end of burner tube). The igniter should glow bright red. Check all connections to be sure they are tight. If the igniter does not heat, replace hot surface igniter.

	Ignition control	After 45 seconds of hot surface igniter pre-heat, the ignition control will switch 24 VAC to the gas control valves. Check for 24 VAC output from the ignition control, across terminals marked "valve" and "valve gnd". If no voltage is present, replace the ignition control. NOTE: The ignition control contains a safety lockout circuit. If a flame is not detected within 6 seconds after the gas control valve is energized, the ignition control will lockout. To reset, turn the power switch "off", wait 45 seconds and switch the system "on" to retry ignition.
	Gas control valves	Check for 24 VAC supplied to the gas control valves. If voltage is present, the valves should open. Check for gas pressure at the pressure tap, located in the gas piping just prior to the burner. If there is no gas pressure, and the voltage is supplied to the valves, check piping for obstructions. If there are no obstructions, replace gas control valves.
Flame will not stay lit	Hot surface igniter	The ignition control will keep the gas control valves energized for 6 seconds. At the end of 6 seconds, the hot surface igniter must sense a flame, or the ignition control will go into lockout. (The ignition control requires a minimum of 0.8 micro-amps DC) To check the flame sensing operation, connect a digital multimeter (capable of measuring DC micro-amps) between the "GND burner" terminal on ignition control and the ground wire. NOTE: This is a current measurement and the meter must be connected in series. If these readings are not achieved, check bypass orifice for obstructions, if bypass orifice is clear, replace the hot surface igniter. NOTE: The DC micro-amp test must be conducted with the oven in low flame (bypass) operation. Set the temperature control to its lowest setting.
	Power supply	If there is sufficient micro-amp current, but the flame will not stay lit, check for proper polarity of the 120 VAC power supply.
	Ignition control	If there is sufficient micro-amp current, and the 120 VAC polarity is correct, but the flame will not stay lit, replace the ignition control. NOTE: check for proper ground connection of the ignition control.
	NOTE: Flame should be lit at this time	
Low flame is on, but no main flame	Control transformer	Check for 120 VAC supply to the primary of the control transformer. If no voltage is present, trace wiring back to the oven power relay. If voltage is present, check for 24 VAC at the transformer secondary. If there is primary voltage but no secondary voltage, replace control transformer.

	Oven control	<p>Check for 24 VAC supply to control. If no voltage is present, trace wiring back to control transformer. If 24 VAC is present, check for a read-out on the control display. If there is 24 VAC supplied, but there is no read-out on the control display, replace the oven control.</p> <p>If there is a read-out on the control, set the control to maximum temperature (see installation operations manual for temperature adjustment). With the control set at maximum temperature, check for 120 VAC at temperature regulation valve. If there is voltage at the temperature regulation valve, proceed to "temperature regulation valve" for next check. If there is no voltage at the temperature regulation valve, trace wiring back to the oven control. If there is no voltage output at the oven control, Check the read-out on the control. If the control reads "LP FAIL" or "RP FAIL", this indicates that the thermocouple has failed or has become disconnected from the control. "LP FAIL" indicates a problem with the left thermocouple probe, and "RP FAIL" indicates a problem with the right thermocouple probe.</p>
	Thermocouple	<p>Check to be sure that the thermocouple is securely connected to the oven control. If the thermocouple is connected to the oven control, and the control indicates "LP FAIL" or "RP FAIL", disconnect the thermocouple from the oven control and measure the resistance of the thermocouple. The left thermocouple should read approx. 21Ω. The right thermocouple should read approx. 11Ω. If these readings are not achieved, replace the thermocouple. If these readings are correct, proceed.</p>
	Oven control	<p>If the thermocouple checks good, but the oven control display indicates that there is a thermocouple failure, replace the oven control. If the oven control indicates a temperature reading but the oven will not heat, proceed.</p>
	Thermocouple	<p>WITH POWER ON AND THERMOCOUPLE ATTACHED TO THE OVEN CONTROL: Measure the DC millivolt output of the thermocouple. Refer to the thermocouple chart (located in the "Removal" section of the manual) for proper millivolt readings. If these readings are not achieved, replace thermocouple.</p>
	Oven control	<p>If the thermocouple checks good, but there is no 120VAC output to the temperature regulation valve, replace the oven control. If there is 120VAC output to the temperature regulation valve, proceed.</p>
T	temperature regulation valve.	<p>Check for 120VAC supplied to temperature regulation valve. If voltage is present, listen for valve to open and close. Also check for opens or shorts in the operating coil. Replace temperature regulation valve as needed.</p>
Intermittent heating	Thermal/overload of main fan and burner blower motors	<p>The main fan motors and burner blower motors are equipped with internal thermal protection and will cease to operate if overheating occurs. As the motors overheat and then cool, this will cause the heating systems to cycle on and off intermittently. Improper ventilation or lack of preventive maintenance may cause this problem. Also, most of the problem listed under "Oven will not heat" can cause intermittent failure.</p>
Conveyor will not run	Power supply	<p>Check for incoming voltage at line 1 to neutral. There should be a voltage reading of 120VAC. If not present, check circuit breakers.</p>
	Power switch	<p>Check continuity between switch terminals. Replace switch as needed.</p>
	Fuse, 10 Amp	<p>Check, replace if necessary.</p>
	Fuse holder	<p>Check, replace if necessary.</p>

Hi-limit	thermostat(s), control box	Check for voltage on both sides of the switch. Terminals are normally closed. If open, reset and test oven for proper operation. If thermostat will not hold, and control box temperature is not exceeding 140°F (60°C), replace thermostat
	Relay, oven power	Check for 120 VAC to the relay coil. If voltage is not present, Trace wiring back to the hi-limit thermostat. If voltage is present, check to insure contacts are closing. Check for 120 VAC supplied to terminal #2 of the relay. If voltage is not present at terminal #2, trace wiring back to the 10 Amp fuse. Replace relay as needed.
	Control transformer	Check for 120 VAC supply to the primary of the control transformer. If no voltage is present, trace wiring back to the oven power relay. If voltage is present, check for 24 VAC at the transformer secondary. If there is primary voltage but no secondary voltage, replace control transformer.
	Conveyor motor	Check for 120 VAC supply to the conveyor motor at wire #14 to neutral. If no voltage is present, trace wiring back to the primary of the control transformer. If voltage is present and the motor will not run, check the motor windings for opens or shorts. WITH POWER OFF: Check the motor windings as follows: Grey to black - 38Ω approx. Grey to blue - 38Ω approx. Blue to black - 75Ω approx. If any of the above fails, replace conveyor motor.
Cap	acitor, conveyor motor	Check for shorts or grounds. Replace capacitor as needed. WARNING: Capacitor has a stored charge, discharge before testing.
Switch,	conveyor reversing	Check continuity between switch terminals. Replace switch as needed.
	Oven control	If there is 120VAC supplied to the motor, and the motor, capacitor, and reversing switch check good, replace the oven control.
Conveyor motor runs, but there is no speed display	NOTE: Display will indicate "Belt Jam"	
	Oven control	Check for output voltage from oven control to hall effect sensor (sensor is located in conveyor motor). Measure voltage at the motor connector, red wire and yellow wire. Voltage should be approx. 10VDC. If no voltage is present, trace wiring back to oven control. If there is no voltage present at the oven control, replace the oven control.
	Conveyor motor	If there is voltage supplied to the hall effect sensor, check for a frequency output from the hall effect sensor. Measure frequency across the yellow and white wires at the motor connector. Frequency reading should be approx. 25 – 100 Hz. If these readings are not achieved, replace conveyor motor. If the readings are achieved, proceed.
	Oven control	If the hall effect sensor readings are correct, but there is no speed indicated on the display, replace the oven control.



## REMOVAL, INSTALLATION & ADJUSTMENTS

MODEL SERIES 1600 ADVANTAGE SERIAL NUMBER L28563 AND ABOVE  
(OVENS WITH PUSH BUTTON CONTROLS)

### CAUTION !

BEFORE REMOVING OR INSTALLING ANY COMPONENT IN THE IMPINGER OVEN BE SURE TO DISCONNECT ELECTRICAL POWER AND GAS SUPPLY

#### BURNER BLOWER MOTOR - REPLACEMENT

- A. Remove appropriate control box cover.
  - B. Unplug motor connector.
  - C. Remove three (3) screws from blower tube at burner housing.
  - D. Remove air shutter assy. from old motor for installation on new motor assy.
  - E. Reassemble in reverse order and check system operation.
- NOTE: CHECK AIR SHUTTER ADJUSTMENT- Should be set at 1/2 open.

#### HOT SURFACE IGNITER - REPLACEMENT

- A. Remove appropriate control box cover.
  - B. Disconnect gas line at union.
  - C. Remove four (4) nuts from burner orifice bracket.
  - D. Remove tube for bypass flame.
  - E. Unplug connector at burner housing.
  - F. Remove three (3) screws from burner housing end cap and remove hot surface igniter and burner tube assy.
  - G. Replace igniter assembly and reassemble in reverse order. CAUTION: USE CARE NOT TO DAMAGE NEW IGNITER.
- NOTE: Check all gas line fittings for leaks. Make sure connector is seated properly.

#### CONVEYOR DRIVE MOTOR - REPLACEMENT

- A. Shut off power at main breaker.
- B. Remove conveyor.
- C. Remove control panel top and front cover.
- D. Disconnect wiring from motor and mark for reassembly.
- E. Remove sprocket from motor drive shaft.
- F. Remove 4 screws and remove conveyor motor and mounting bracket.
- G. Remove mounting bracket from conveyor motor assembly.
- I. Reassemble in reverse order.

#### CAPACITOR, CONVEYOR MOTOR – REPLACEMENT

- A. Shut off power at main breaker.
- B. Remove control box cover and front panel.
- C. Discharge capacitor before removing wires. Mark wires for reassembly.
- D. Remove mounting screw and remove capacitor.
- E. Reassemble in reverse order and check system operation.

#### REVERSING SWITCH – REPLACEMENT

- A. Shut off power at main breaker.
- B. Remove control box cover.
- C. Disconnect wiring from reversing switch and mark for reassembly.
- D. Remove mounting nut and remove reversing switch.
- E. Reassemble in reverse order and check system operation.

### REVERSING CONVEYOR DIRECTION.

- A. Shut off power at oven switch.
- B. Set conveyor reversing switch in the other position.
- C. Turn oven "on" and check for proper operation.

### FUSEHOLDER - REPLACEMENT

- A. Remove appropriate control box cover.
- B. Remove two (2) wires, note wire number and location.
- C. Remove lock nut on back side of fuse holder and push out.
- D. Reinstall in reverse order and check system operation.

### GAS VALVE, DUAL SAFETY - REPLACEMENT

- A. Remove appropriate control box cover.
- B. Remove incoming gas line.
- C. Remove screws from incoming nipple mounting bracket.
- D. Remove incoming nipple.
- E. Remove bypass tube assy.
- F. Disconnect pipe union.
- G. Disconnect wiring from control valve (four [4] push on connectors), make note of wire numbers and location for reinstallation.
- H. Remove gas piping from old valve and install on new one.
  - I. Reassemble in reverse order and check system operation. Set manifold pressure on gas valve. Pressure should be 3.5 in W.C. Nat., 10 in W.C. L.P.

NOTE: Check all gas line fittings for leaks, check and adjust manifold pressure.

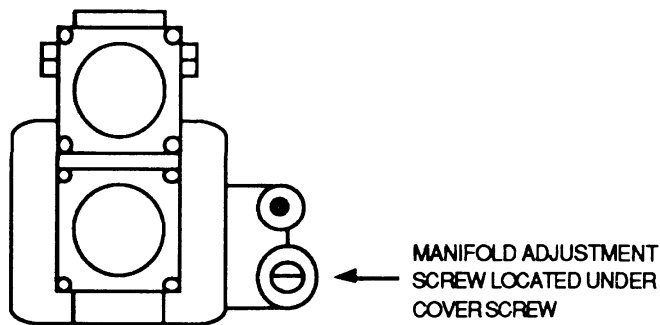

### TEMPERATURE REGULATING VALVE - REPLACEMENT

- A. Remove appropriate control box cover
- B. Remove bypass tube assy.
- C. Remove four (4) nuts from burner orifice bracket.
- D. Disconnect pipe union.
- E. Disconnect two (2) wires from valve and remove assembly.
- F. Remove gas piping from old valve and install on new one.
- G. Reassemble in reverse order and check system operation. NOTE: Check all gas line fittings for leaks and insure valve gas flow is in proper direction .

## **MAIN ORIFICE - REPLACEMENT**

- A. Remove appropriate control box cover.
  - B. Remove bypass tube assembly.
  - C. Remove four (4) nuts from burner orifice bracket.
  - D. Disconnect pipe union.
  - E. Remove assembly and replace main orifice.
  - F. Reassemble in reverse order and check system operation.
- NOTE: Check all gas line fittings for leaks.

## **BYPASS ORIFICE – REPLACEMENT**

- A. Shut off power at main breaker.
- B. Remove appropriate control box cover.
- C. Remove pilot tube from bypass orifice and remove orifice.
- D. Reassemble in reverse order and check system operation. Check all gas connections for leaks.

## **ON-OFF SWITCH (POWER) - REPLACEMENT**

- A. Remove control box cover.
  - B. Depress spring clips on side of switch and push out.
  - C. Remove wires from back of switch, note wire number and location.
  - D. Reassemble in reverse order and check system operation.
- NOTE: Make sure switch housing is fully seated in control box housing.

## **BURNER CONTROL TRANSFORMER, - REPLACEMENT**

- A. Remove appropriate control box cover.
- B. Remove two (2) wires on primary side, note color and location.
- C. Remove two (2) wires on secondary side, note color and location.
- D. Remove two (2) screws from transformer base and replace assembly.
- D. Reinstall in reverse order and check system operation.

## **CONTROL TRANSFORMER – REPLACEMENT**

See “BURNER CONTROL TRANSFORMER” above.

## **CAPACITOR, MAIN FAN MOTOR (7.5 MFD/370V) - REPLACEMENT**

- A. Remove appropriate control box cover.
- B. Remove two (2) wires from capacitor, note wire number and location.  
WARNING: Capacitor has a stored charge, discharge before handling or testing.
- C. Cut two (2) tyrapts securing capacitor to base and replace.
- D. Reinstall in reverse order and check system operation.

## **RELAY - REPLACEMENT**

- A. Remove control box cover.
- B. Remove wires from relay, note wire numbers and location for reinstallation.
- C. Remove two (2) screws from relay base and replace relay.
- D. Reassemble in reverse order making sure wire connectors are properly seated.
- E. Check system operation.

## **THERMOSTAT, COOLING FAN - REPLACEMENT**

- A. Remove appropriate control box cover.
- B. Remove two (2) wires from thermostat, note wire number and location.
- C. Remove two (2) mounting screws and replace thermostat.
- D. Reassemble in reverse order and check system operation.

## HIGH LIMIT THERMOSTAT - REPLACEMENT

- A. Remove appropriate control box cover.
- B. Remove two (2) wires from thermostat, note wire numbers and location for reinstallation.
- C. Remove screws from bracket and remove thermostat.
- D. Reassemble in reverse order and check system operation.

**NOTE:** Depress reset button to insure thermostat is set for operation.

## COOLING FAN MOTOR(S) - REPLACEMENT

- A. Remove appropriate control box cover.
- B. Remove four (4) mounting screws.
- C. Unplug electrical connector and remove fan motor assembly.
- E. Reassemble in reverse order and check system operation.

## MAIN FAN MOTOR - REPLACEMENT

- A. Shut off gas supply and remove gas line and manifold lines from back of oven.
- B. Remove screws from motor cover housing and lift off.  
**NOTE:** When ovens are stacked, all motor cover housings are fastened together.
- C. Unplug power connector .
- D. Unplug thermocouple.
- E. Unplug two (2) motor connectors.
- F. Remove eight (8) bolts from oven back (4 left, 4 right) and lift out.
- G. Remove one (1) screw from fan hub and slide fan blade off of motor shaft.  
(Note location of fan blade for reinstallation).
- H. Loosen lock nuts on cone. Remove two mounting bolts and remove motor from back assy.
- I. Remove four (4) hex head screws from motor mount bracket.  
Remove motor mount from motor and reinstall on new motor.
- J. Reassemble in reverse order.

**NOTE:**

- 1. Make sure motor is centered in back housing.
  - 2. Verify correct location of fan blade and that it is not hitting fan shroud.
  - 3. Make sure all connectors are properly seated and making good contact.
  - 4. When reinstalling gas manifold across back of oven, check all fittings for leaks.
- K. Check system operation (allow 30 minute preheat for all checks).  
**NOTE:** Position of the fan on the motor shaft will be 1.875" from the top of the oven back cone to the blade spider assembly on the fan hub. (See drawing below.)

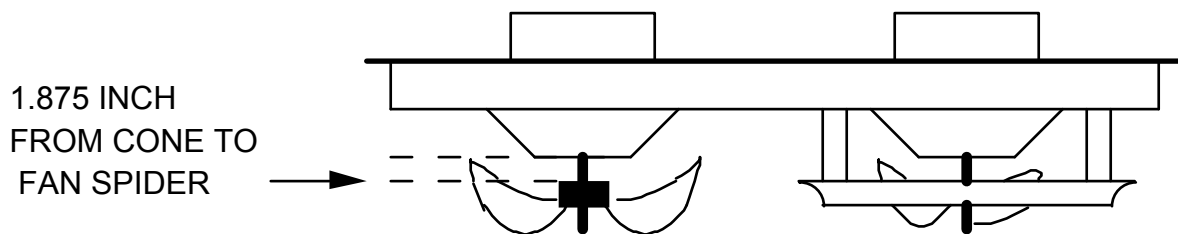

## THERMOCOUPLE (TYPE "K") - REPLACEMENT

- A. Remove control box covers. Remove motor cover and remove oven back to access thermocouple.

**NOTE:** Removal of oven back assy. is required to replace thermocouples.

- B. Remove thermocouple from wire form in oven chamber and remove from chamber.  
**NOTE:** R. H. Thermocouple (viewed from front) is connected directly to the Oven control, unplug thermocouple from oven control and remove thermocouple. When changing L.H. Thermocouple (viewed from front), the back motor cover must also be removed to gain access to the thermocouple connector plug.

- C. Reassemble in reverse order making sure bulb is placed securely in the wire form in the oven chamber.
- D. Check system operation, recalibrate as needed. NOTE: The R.H. and L.H. Thermocouples are different (R.H. one piece, L.H. two piece) and must be ordered accordingly.

### **THERMOCOUPLE MEASUREMENT**

TEMPERATURE	D.C. MILLVOLTS (APPROX.)
200°	2.8
250°	4.0
300°	5.1
350°	6.0
400°	7.1
450°	8.2
500°	9.3
550°	10.4
600°	11.5

### **BEARING, CONVEYOR - REPLACEMENT**

- A. Remove conveyor from oven and place on a flat work surface.
- B. Remove connecting links from conveyor belting. See Installation and Operating Instructions Manual.
- C. Remove conveyor belting from conveyor. Remove drive sprocket from drive shaft.
- D. Move drive shaft or idle shaft toward end of conveyor, and shaft with bearing will now slip out of holding bracket.
- F. Replace bearing and reassemble.

### **OVEN CONTROL – REPLACEMENT**

- A. Shut off power at main breaker.
- B. Remove control box cover and front panel.
- C. Remove all wiring connections and mark for reassembly.
- D. Remove oven control by pulling control from the mounting pins. Remove control from oven.
- E. Before installing new oven control, set voltage jumper (located at the bottom center of the oven control) to the proper voltage (120V/240V) position. Install the four pushbutton extensions (included with the oven control) by pushing the extensions onto the four set buttons on control.
- F. Reassemble in reverse order and check system operation.
- G. Set the oven control for the proper operating mode. The 1600 series ovens have dual burner systems. The oven control must be set to the “Dual oven mode”. Set the control as follows: With the oven power switch “off”, depress the “temp” and “down” buttons and turn the oven “on”. Control will indicate “Low Pro”. Release the buttons, The control will indicate “Temp to store”. Press the “temp” button. The control is now set for dual burner operation.

**GENERAL  
1600 ADVANTAGE SERIES**

<b>LETTER</b>	<b>PART #</b>	<b>DESCRIPTION</b>
	A	369110 Access Window Assy
B	369929	Window Retainer
	C	369926 Window Frame, Bottom
	D	369925 Glass, Access Window
	E	369927 Window Frame, Top
F	369930	Screw, 10-32x1/4
G	369211	Thumb Screw
H	369058	Baffle
	I	370253 Drive Cover L.H.
J	1609	Oven Top
	K	370252 Drive Cover L.H.
	L	369745 Hinge Assy., Right
	M	369723 Door Assy., Small
N	369783	Latch, Spring
	O	369717 Finger Retaining Bracket
	P	369057 Screw, Finger Retaining Bracket
Q	369501	Latch
R	369238	Leg
	S	369030 Caster, High Stand
		369390 Caster, Low Stand
	T	370167 Baffle, Air Return U.L. L.R. (S/N 35950 & below)
		370663** Baffle, Air Return U.L. (S/N 35951 & above)
	U	370166 Baffle, Air Return U.R. L.L. (S/N 35950 & below)
		370662** Baffle, Air Return U.R. (S/N 35951 & above)
	V	370168 Finger Housing T-1, T-3, B-2, B-4 (S/N 35950 & below)
		370665*** Finger Housing T-1, T-3, B-2, B-4 (S/N 35951 & above)
		370169 Finger Housing T-2, T-4, B-1, B-3 (S/N 35950 & below)
		370664*** Finger Housing T-2, T-4, B-1, B-3 (S/N 35951 & above)
	W	Columnating Plates--See Installation Operations Manual
X	369707	Finger Cover
Y	369740	Handle Assy.
	Z	369718 Door Assy., Large
AA	369931	Screw, 8-32x3/8
	BB	369746 Hinge Assy. Left

**\*\* Units from S/N 35951 and above DO NOT contain lower Air Return Baffles. These units only contain a total of two (2) Air Return Baffles which are placed above the top finger assemblies.**

**\*\*\* These parts have minor design changes not shown in the exploded view drawing on page 15.**

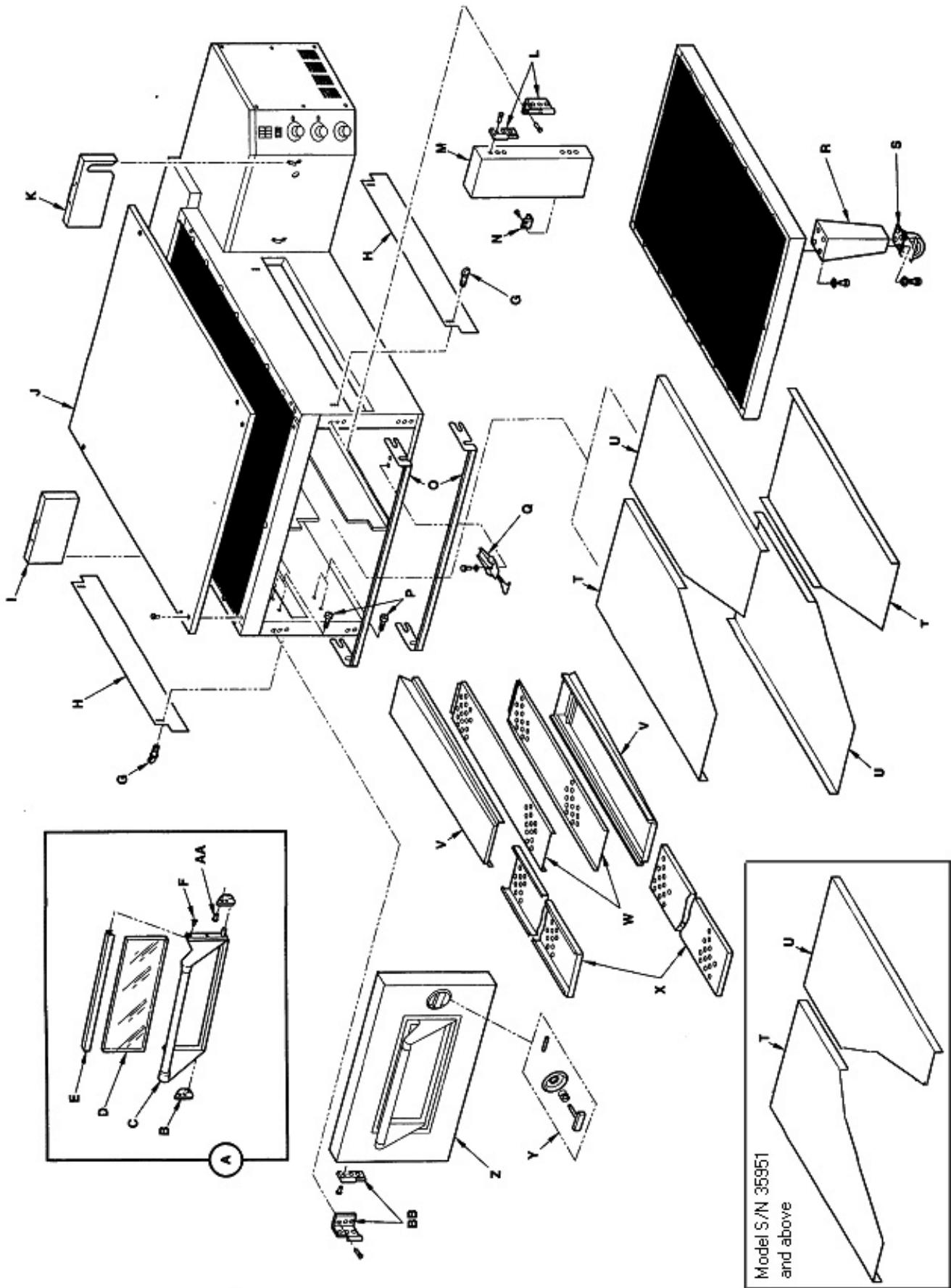

Model S/N 35951  
 and above

**STAINLESS STEEL ACCESS DOOR  
ALL MODELS (SN 0908210000875 AND ABOVE)**

LETTER	PART NUMBER	DESCRIPTION
	369110	Access Door Assembly
A	371140	Bracket Assembly, Left
B	371142	Dowel, Access Door
C	370722	Screw
D	371143	8-32 x 3/8 Hx Serr Flng
E	371141	Bracket Assembly, Right
F	370725	Dowel Thread
G	371144	Access Door Frame (top or bottom)
H	370723	Glass

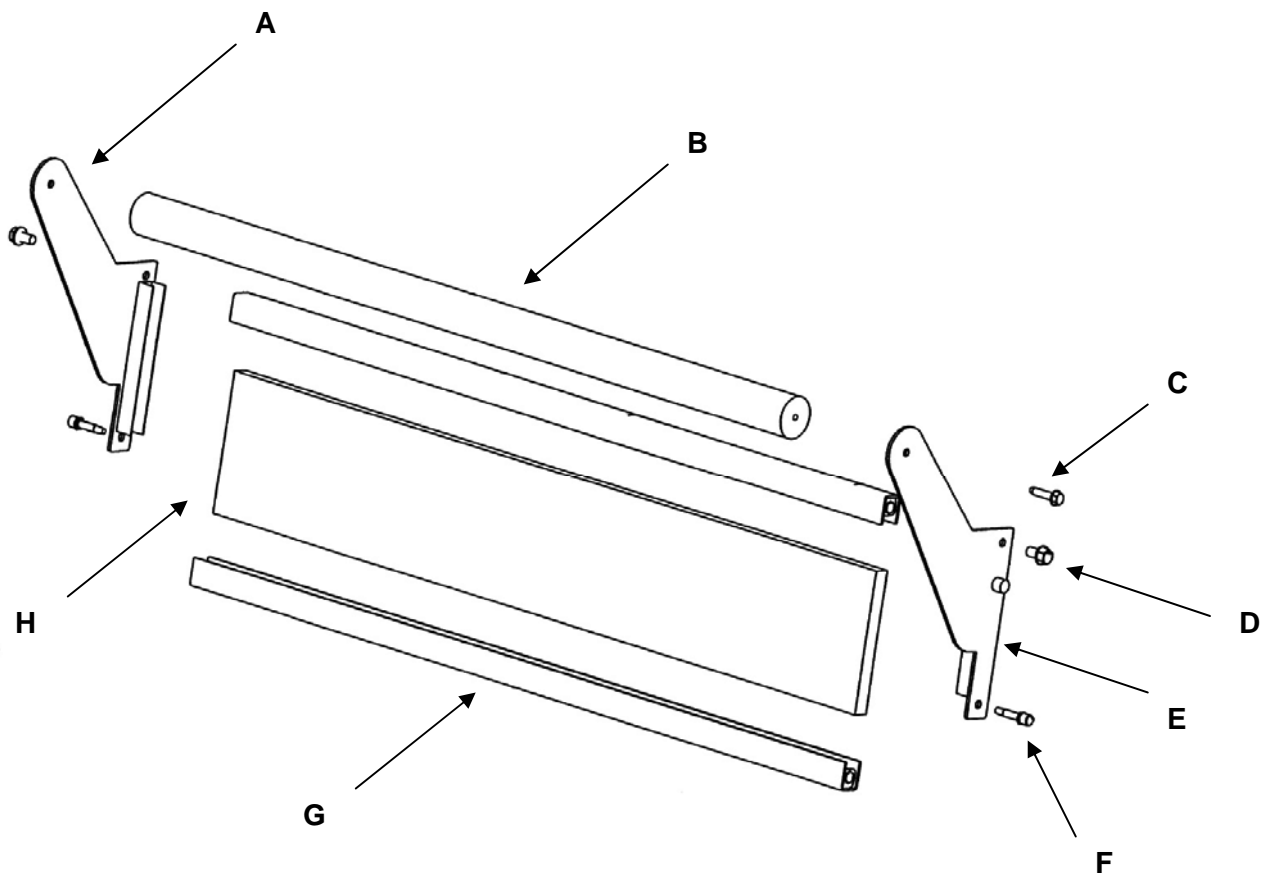



This page intentionally left blank.

CONTROL BOX, RIGHT  
1600-000-A, 1601-000-A  
S/N L28563 AND ABOVE

LETTER	PART NUMBER	DESCRIPTION
A	369161	Sprocket, Drive
B	370357	Thermocouple, Type K
C	369757	Main Orifice, Nat.
	370279	Main Orifice, L.P.
D	369398	Solenoid Valve
E	369552	Hot Surface Igniter
F	369755	Venturi, Nat.
	369642	Venturi, L.P.
G	369401	Air Shutter Assy.
H	369366	Burner Blower Motor
I	369263	Gas Valve
J	369556	By-Pass Orifice, Nat.
	370276	By-Pass Orifice, L.P.
K	370251	Control Box Top R.H.
L	3530	82 Ground Lug
M	369537	Power Cord
N	369124	Cooling Fan
O	369531	Transformer, 24 VAC Secondary
P	370359	Reversing Switch
Q	369192	Capacitor
R	369012	Fuse Holder
S	369013	Fuse, 3 A
	369014	Fuse, 10 A
T	369507	Thermostat, Cooling Fan
U	369431	Thermostat, Control Box Hi-Limit
V	370352	Capacitor, Conveyor Motor
W	370353	Conveyor Motor
X	369532	Ignition Control
Y	370354	Facia, Label
Z	370355	Control, Oven
AA	370256	Side Panel R.H.
BB	369805	Switch, Power
CC	369523	Relay
Not shown	370495	Bracket, cooling fan, RH S/N L32631 and above

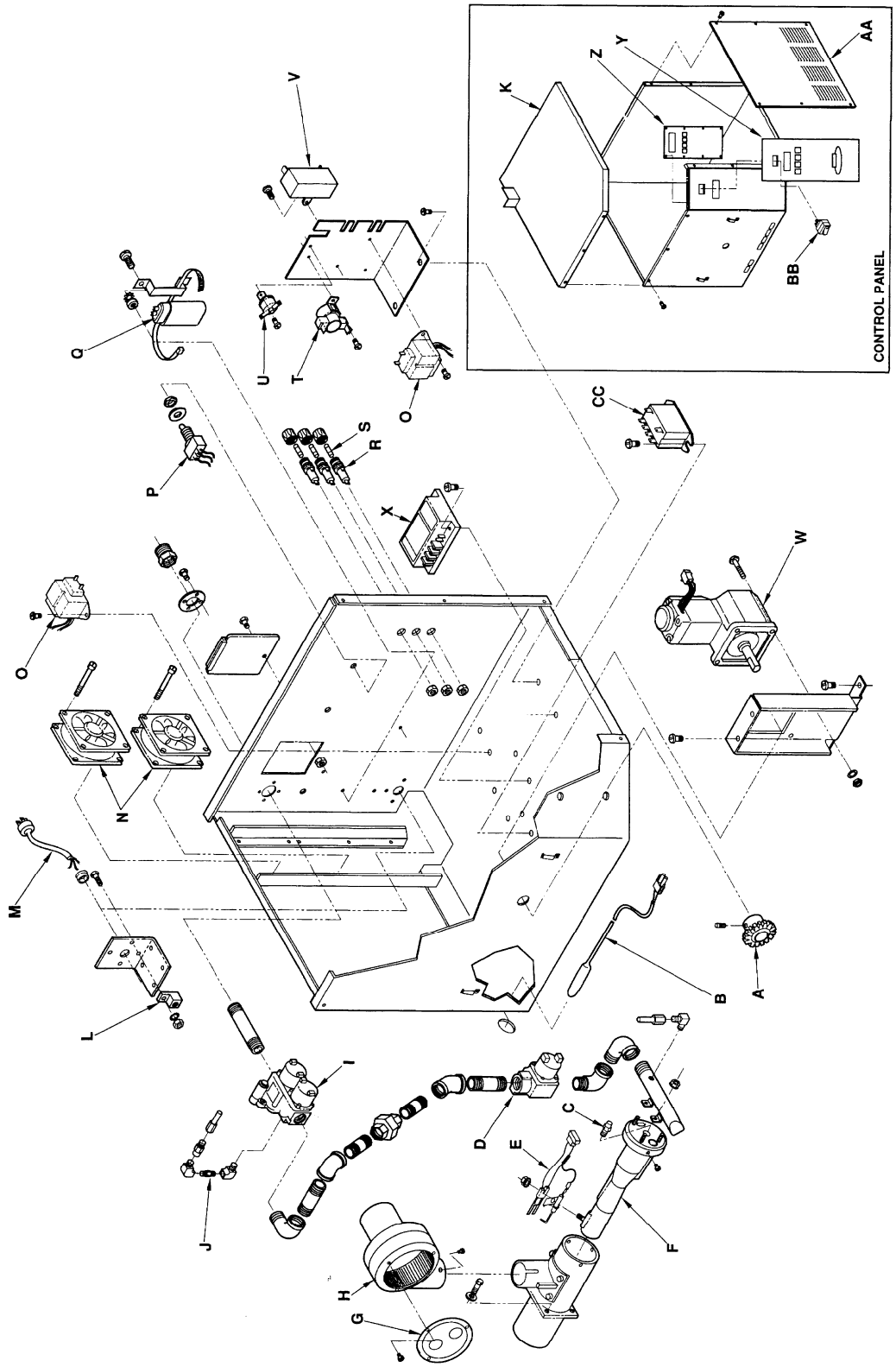

CONTROL BOX, LEFT  
1600-000-A, 1600-000-A  
S/N L28563 AND ABOVE

LETTER	PART	#	DESCRIPTION
A	370358		Thermocouple with Extension, Type K for S/N L28563 and Above
B	369507	Therm	ostat, Cooling Fan
C	369431	Therm	ostat, Control Box Hi-Limit
D	369532	Ignition	Control
E	369531	Tran	sformer, 24 VAC
F	369012	Fuse	Holder
G	369014	Fuse,	10 A
H	369192	Cap	acitor
I	369124	Cooli	ng Fan
J	369556	By-Pass	Orifice, Nat.
	370276	By-Pass	Orifice, L.P.
K	369263	Gas	Valve
L	369366	Burne	r Blower Motor
M	369401	Air	Shutter Assy.
N	369552	Hot	Surface Igniter
O	369755	Venturi,	Nat.
	369642	Venturi,	L.P.
P	369398	Solenoid	Valve Nat/LP
Q	369757	Main	Orifice, Nat.
	370279	Main	Orifice, L.P.
R	370272	Side	Panel L.H.
S	370250	Control	Box Top, L.H.
Not shown	370496		Bracket, cooling fan, LH S/N L32631 and above

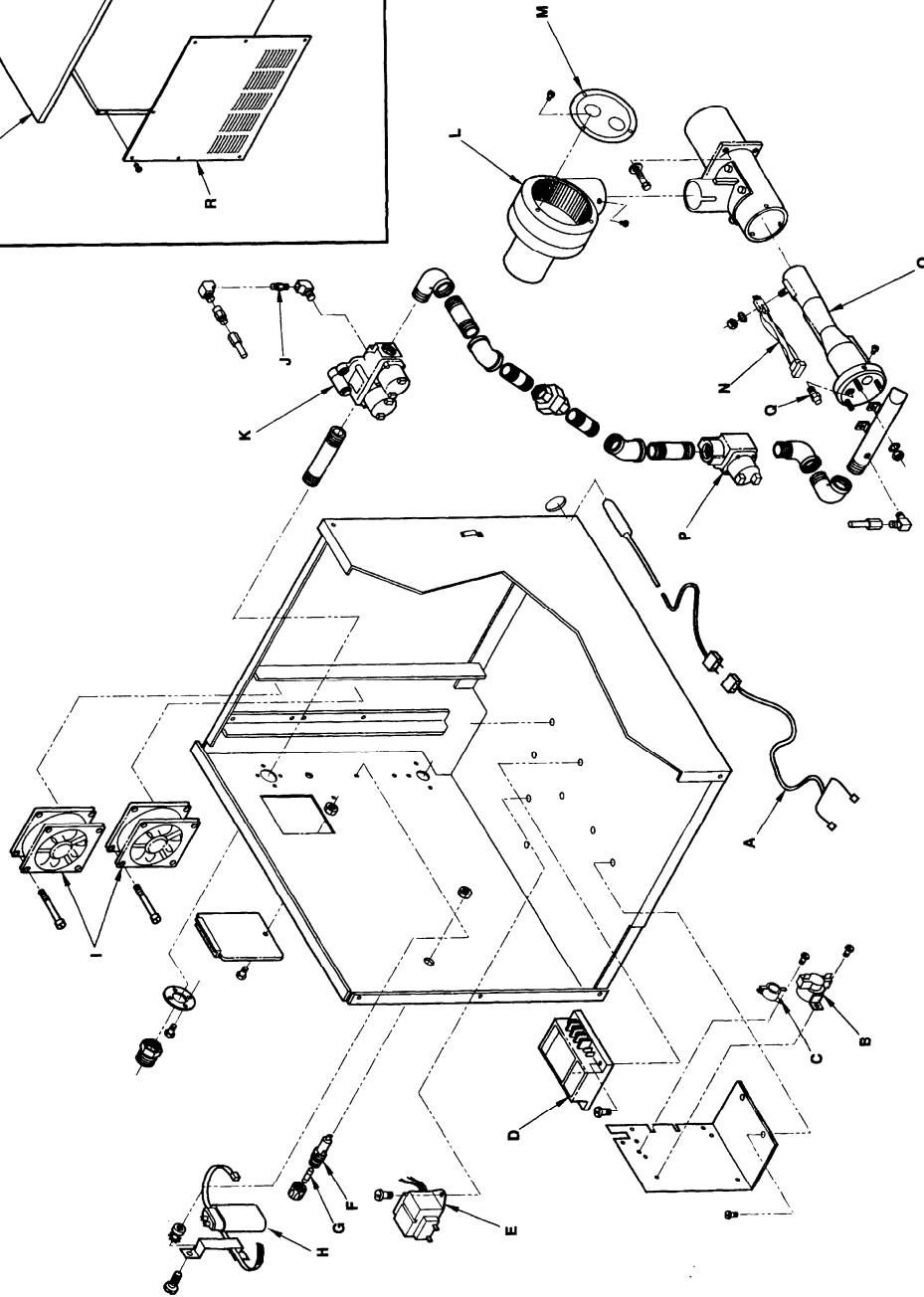
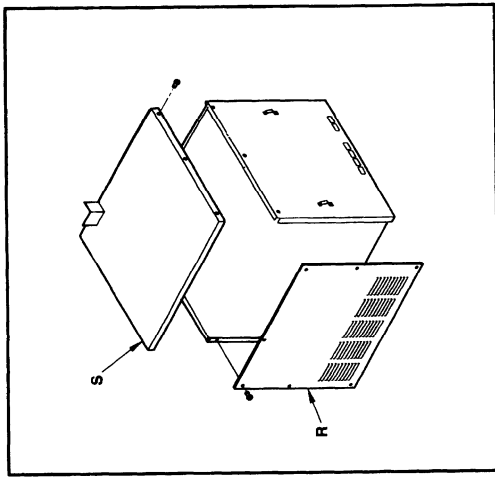

OVEN BACK  
1600 ADVANTAGE SERIES

	LETTER PART	#	DESCRIPTION
	A	369547	Wire Form Thermostat Bulb
	B	369725	Fan, Clockwise Rotation
C		369776	Fan Shroud
D		369777	Stand-Off
	E	369778	Rear Wall Assy.
F		369761	Motor Mount
	G	369726	Motor, Main Fan 120V 60 Hz
H		1627	Duct Cap
I		369033	Motor Clamp
J		370245	Rear Duct
K		370246	Manifold Assy.
L		369724	Fan, Counter-Clockwise Rotation

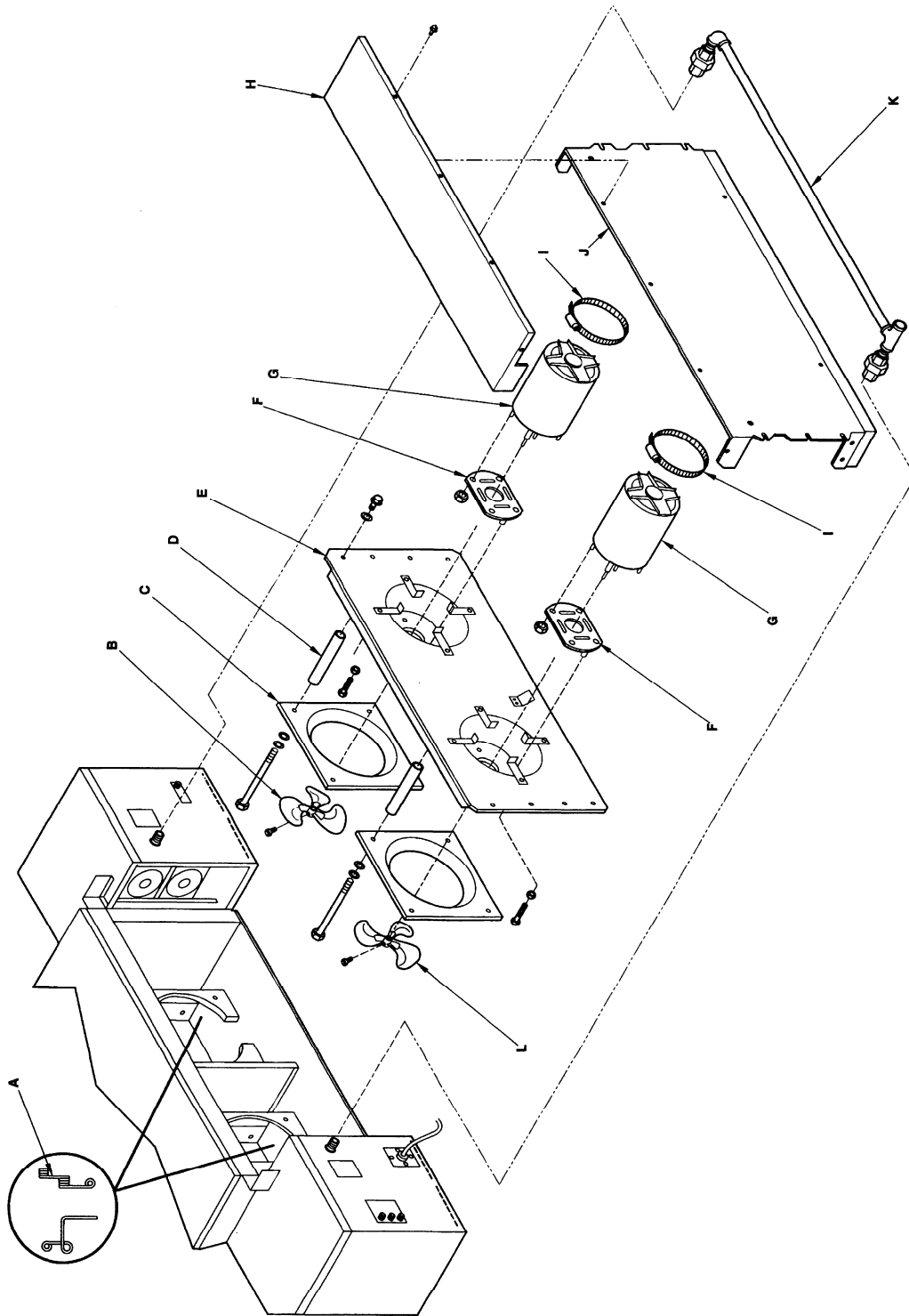

## CONVEYOR 1600 ADVANTAGE SERIES

LETTER	PART	#	DESCRIPTION
A		369830	Complete Conveyor
		369816	Conveyor Belting
		370092	Belt, 1 Foot Section
B		369825	Retaining Ring
	C	369813	Conveyor Bearing Block
	D	369314	Roll, Conveyor, Notched
	E	369812	Conveyor Idler Shaft
	F	369160	Conveyor Pan Stop
G		369814	Connecting Link
	H	369811	Conveyor Drive Shaft
J		369161	Roller Chain Sprocket
K		369806	Crumb Pan
L		370050	Conveyor Frame
M		370247	Drive Chain



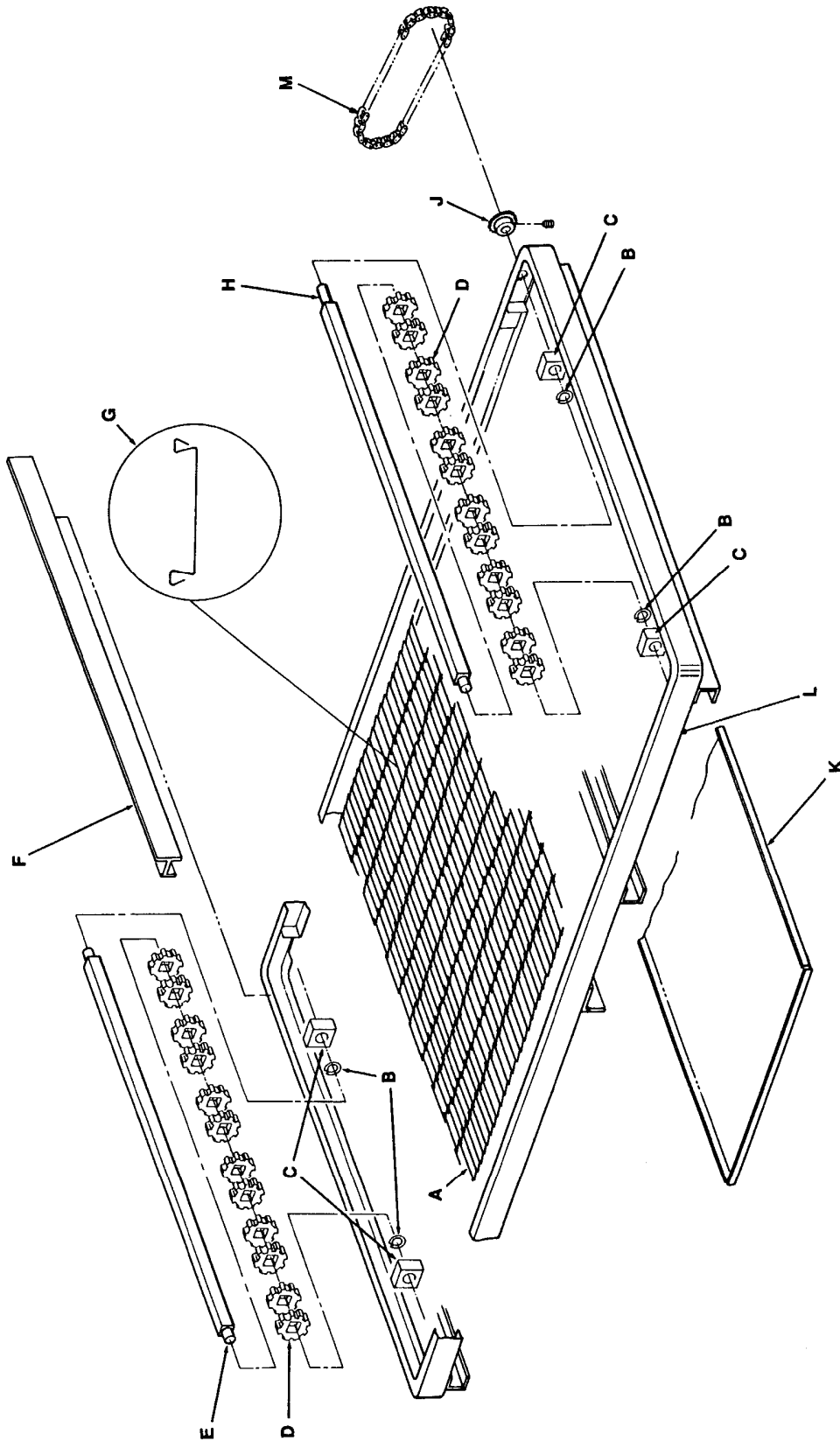

This page intentionally left blank.

This page intentionally left blank.

