

Operator's Manual

CAYENNE® FULL-SIZE WARMER



Item	Description	Voltage	Watts	Amps	Plug
71001	Full-size Warmer (US)	120	700	5.8 Amps	5-15P
72620	Full-size Warmer (CE)	230	700	3.0 Amps	Schuko
72553	Full-size Warmer (CE)	230	700	3.0 Amps	UK
72625	Full-size Warmer (CE)	230	700	3.0 Amps	Schuko
72626	Full-size Warmer (CE)	230	700	3.0 Amps	Schuko

Thank you for purchasing this Vollrath Equipment. Before operating the equipment, read and familiarize yourself with the following operating and safety instructions. **SAVE THESE INSTRUCTIONS FOR FUTURE REFERENCE.** Save the original box and packaging. Use this packaging to ship the equipment if repairs are needed.



SAFETY PRECAUTIONS

To ensure safe operation, read the following statements and understand their meaning. Please read carefully.

WARNING

Warning is used to indicate the presence of a hazard that *can* cause *severe* personal injury, death, or substantial property damage if the warning is ignored.

CAUTION

Caution is used to indicate the presence of a hazard that *will* or *can* cause *minor* personal injury or property damage if the caution is ignored.

NOTE

Note is used to notify people of installation, operation, or maintenance information that is important but not hazard-related.

For Your Safety!

These precautions should be followed at all times. Failure to follow these precautions could result in injury to yourself and others.

To reduce risk of injury or damage to the equipment:

- Use only grounded electrical outlets matching the nameplate rated voltage.
- Use equipment only in a flat, level position.
- Do not use an extension cord with this equipment. Do not plug this equipment into a power strip or multi-outlet power cord.
- Turn off equipment, unplug and let it cool before cleaning or moving.
- Unplug equipment when not in use.
- Do not operate without water.
- Do not spray controls or outside of equipment with liquids or cleaning agents.
- Do not clean the equipment with steel wool.
- Keep equipment and power cord away from open flames, electric burners or excessive heat.
- Do not operate unattended.
- Do not operate equipment in public areas and/or around children.
- Do not operate if equipment has been damaged or is malfunctioning in any way.

FUNCTION AND PURPOSE

This unit is intended and designed to keep food at proper serving temperatures. It is not intended or designed to cook raw food or to reheat prepared food. Food must be prepared and placed in food stations at proper serving temperatures.

Before using this equipment it must be cleaned and dried thoroughly.

This equipment is not intended for household, industrial or laboratory use.

UNPACKING THE EQUIPMENT AND INITIAL SETUP

When no longer needed, dispose of all packaging and materials in an environmentally responsible manner.

1. Remove all packing material and tape, as well as any protective plastic from the equipment.
2. Clean any glue residue left over from the plastic or tape.
3. Place the equipment in the desired location.
4. Plug the equipment into a properly grounded electrical supply matching the nameplate rating. Damage to the equipment can occur if incorrect power is supplied to equipment.

FEATURES AND CONTROLS

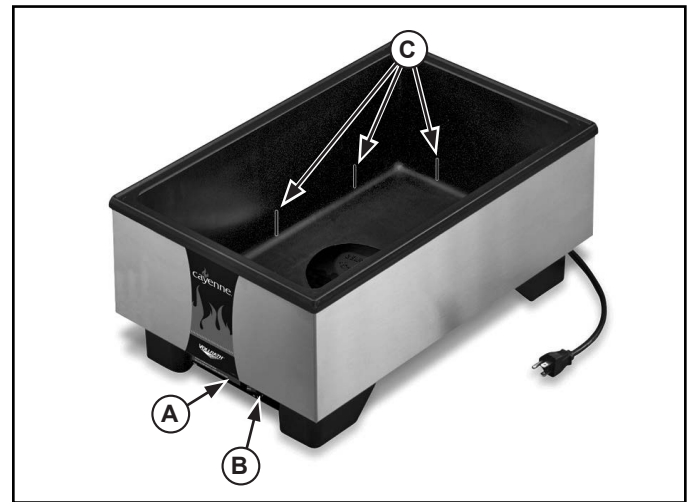



Figure 1. Features and Controls

- Ⓐ **ON/OFF and HEAT CONTROL SWITCH.** Switches the equipment power “ON” or “OFF” and to sets or adjusts the temperature of the well. The higher the number the higher the temperature, the lower the number the lower the temperature.
- Ⓑ **LOW WATER LIGHT (some models).** Illuminates when the well needs water added. If the light illuminates during operation, clean fresh water must be added to the well.
- Ⓒ **WATER LEVEL MARKS.** Indicates the correct water level.



OPERATION

	WARNING
	Electrical Shock Hazard. Keep water and other liquids from entering the inside of the unit. Liquid inside the unit could cause an electrical shock. Do not damaged power cord.
Do not over fill wells, pans or trays. Liquid could contact the electrical components and cause a short circuit or an electrical shock. Unplug unit before performing service, draining or removing spillage pans and trays. Do not spray water or cleaning products. Do not use a power cord that has been modified or damaged.	

	WARNING
	Burn Hazard. Do not touch hot food, liquid or heating surfaces while equipment is heating or operating.
Hot surfaces, steam and food can burn skin. Allow the hot surfaces to cool before handling. Do not drop or spill water onto the cooking surface as it can spray or splatter.	

1. Fill the well to the correct level marks (C) with clean fresh water. The correct level is about 1" (2.5 CM) or approximately 5.5 quarts (5.2 L) of water. Do not over fill. See Figure 1.
2. Plug the electrical power cord into a grounded outlet matching the nameplate rated voltage.
3. Preheat the water in the wells by covering wells with empty food containers or covers. Turn the ON/OFF and heat control switch (A) to the maximum heat setting (10). Preheat for 15 minutes.
4. Place the container of hot food product, above 140 °F (60 °C), into the preheated equipment.
5. Reduce the heat setting to a level that will maintain a safe holding temperature and maintain food quality. See food safety precautionary note.

Food Safety Precautionary Note:

Monitor food temperature closely for food safety. The United States Public Health Service recommends that hot food be held at a minimum of 140 °F (60 °C) to help prevent bacteria growth. Maintain correct water level and temperature setting. Periodically remove food container and check the water level. Add water if needed.

During operation:

6. Maintain water level at or near water level mark. Periodically (approximately 2 hours) remove the container of food and check the water level. Add hot water if needed. Some models are equipped with a low water indicator light (D) that illuminates when the water level is low.

When finished using the equipment:

7. Turn the ON/OFF and heat control switch (A) to the OFF position and unplug the unit. When removing hot food containers from unit use gloves, mitts or pot holders to protect hands.
8. Allow unit and water to completely cool.
9. Carefully empty water from the well.

CLEANING

To maintain the appearance and increase the service life, clean your equipment daily.

	WARNING
	Burn Hazard. Do not touch hot food, liquid or heating surfaces while equipment is heating or operating.
Hot surfaces, steam and food can burn skin. Allow the hot surfaces to cool before handling. Do not drop or spill water into the cooking surface as it can spray or splatter.	

NOTE:

Do not use caustic cleaning chemicals, steel wool or commercial lime removal products to clean the equipment. Thoroughly rinse equipment with water after cleaning.

1. Turn the ON/OFF and heat control switch (A) to the OFF position and unplug the unit. When removing hot food containers from unit use gloves, mitts or pot holders to protect hands.
2. Carefully empty water from the well.
3. Allow the equipment to cool completely before cleaning.

	WARNING
	Electrical Shock Hazard. Keep water and other liquids from entering the inside of the unit. Liquid inside the unit could cause an electrical shock. Do not damaged power cord.
Do not over fill wells, pans or trays. Liquid could contact the electrical components and cause a short circuit or an electrical shock. Unplug unit before performing service, draining or removing spillage pans and trays. Do not spray water or cleaning products. Do not use a power cord that has been modified or damaged.	

NOTE:

Do not immerse the cord, plug or equipment in water or any other liquid.

4. Using a damp cloth, sponge dipped in soapy water to clean the inside of the well and the outside of the equipment.

ENGLISH

TROUBLESHOOTING CHART

Problem	It might be caused by	Course of Action
Low Water Light (some models) illuminates.	Low water in the well.	Add hot water to the well to bring to correct level.
	Pilot light malfunction.	Replace pilot light.
Equipment does not heat.	Heating element malfunction.	Replace heating element.
	Thermostat control malfunction.	Replace thermostat control.
The equipment does not get hot enough.	Too much water in the well.	Reduce water amount to the correct level.

SERVICE AND REPAIR

There are no user serviceable parts within this appliance. To avoid serious injury or damage, never attempt to repair the equipment or replace a damaged power cord yourself. Do not send equipment directly to the Vollrath Company. Please contact the qualified professional repair service listed below.

VOLLRATH Warmer Return • 1-800-354-1970

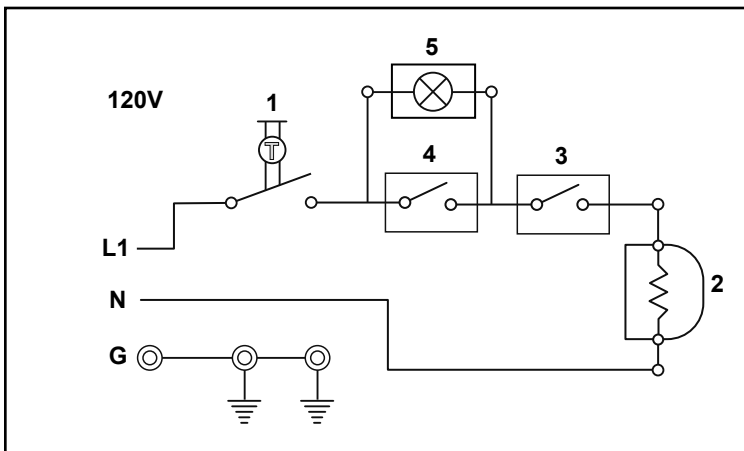
ELECTRICAL DRAWING - CAYENNE FULL-SIZE WARMER, 120V AC, MODEL 71001

Callout	Description
1	Control Thermostat
2	Heating Element, 120V ~ 700 Watt
3	High Limit Switch
4	Low Water Sensor Switch
5	Light, Low Water Warning, 120V

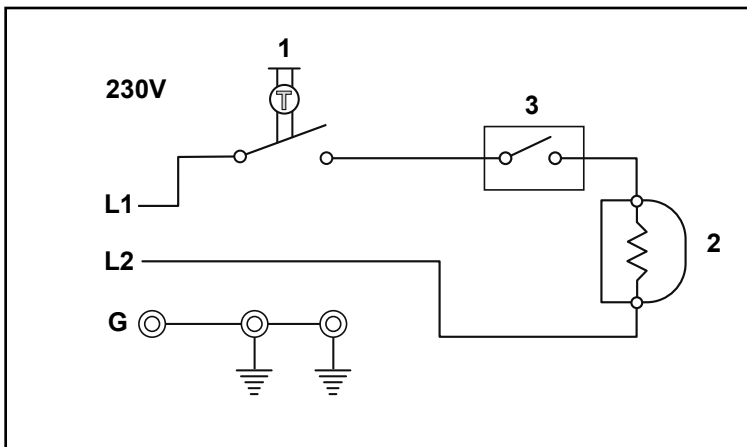
ELECTRICAL DRAWING - CAYENNE FULL-SIZE WARMER, MODELS, 230V AC, MODELS 72620, 72553, 72625, 72626

Callout	Description
1	Control Thermostat
2	Heating Element, 230V ~ 700 Watt
3	High Limit Switch



SPARE PARTS LIST - CAYENNE FULL-SIZE WARMER, MODELS 71001, 72620, 72553, 72625, 72626

Callout	Part Number	Description
1	44455-1	Panel, Control
2	17012-1	Knob, Control
3	17074-1	Thermostat, Short Capillary
4	1755901-1	Pilot light, Blue, 120V models
5	17489-1	Well, no drain
7	17508-1	Label, Control
8	17076-3	M4 x 8mm
9	44204-1	Heater, 120V, 700W
9	44206-1	Heater, 220V/240V, 760W
10	17018-3	Screw, 8-32 x 1/2"
12	17868-1	"D" Shaped Heater Gasket
13	17023	Cord 6ft, 120V, 10A, 5-15p

Callout	Part Number	Description
13	17249-1	Cord 6ft, 220V/240V, Schuko
14	17024-3	Strain Relief
15	17650-1	Decal, Hand Tighten
16	17950-1	Thermostat, Regulating
17	17020-3	Screw, #6-32 x 1/2"
18	17014-3	Screw, #10-32 x 5/8"
20	17928-1	Universal Thermostat Bracket
21	25438-1	Thermostat, Low Water (120V models)
22	17496-3	Screw, #6-32 x 1/4"
23	17019-3	#6-32, Nut, KEPS
24	17605-1	Label, Rating, Food Warmer
	44640-2	Wrapper, Satin Chrome

EXPLODED VIEW - CAYENNE FULL-SIZE WARMER

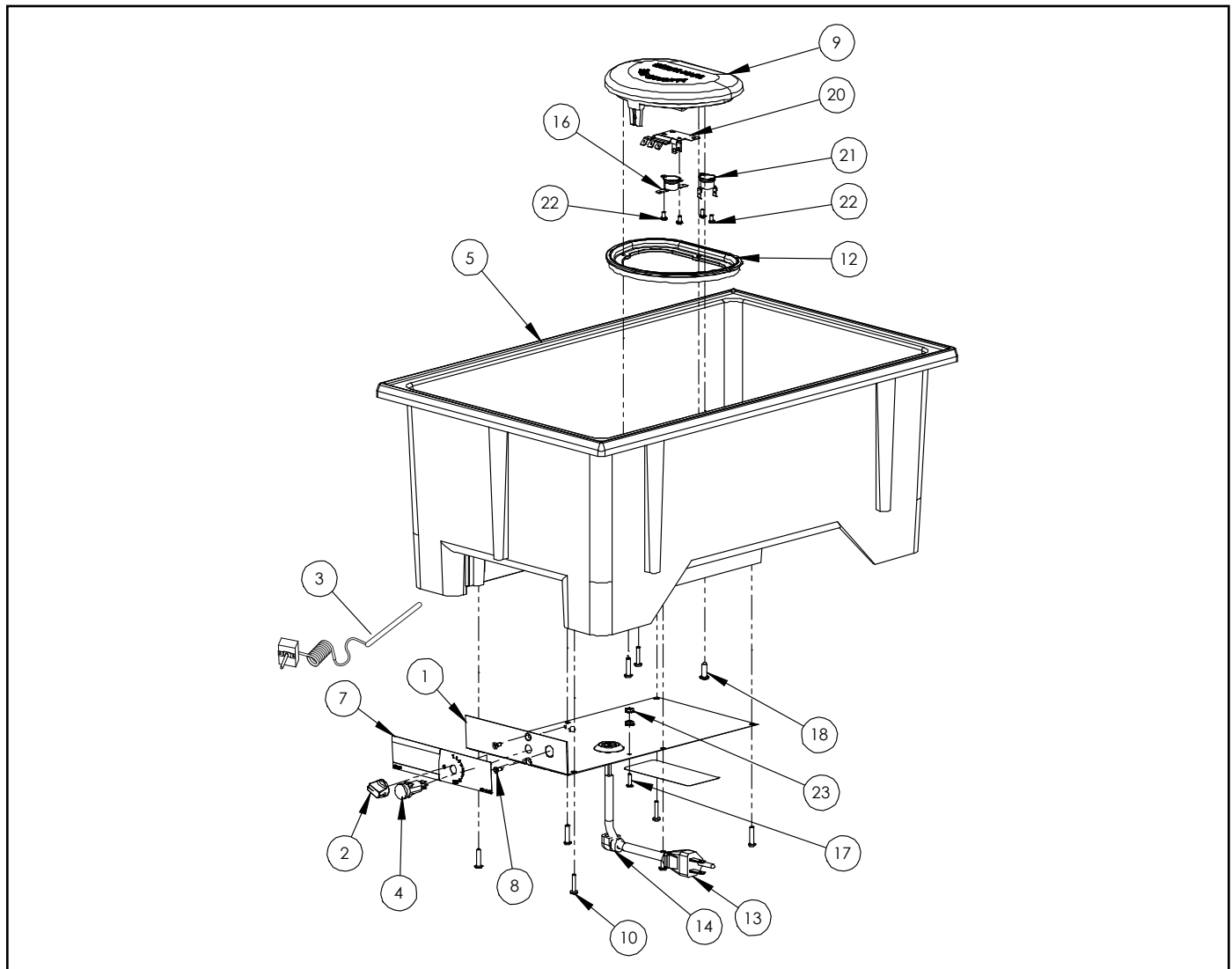

ENGLISH

WARRANTY STATEMENT FOR THE VOLLRATH Co. L.L.C.

The Vollrath Company LLC warrants the products it manufactures and distributes against defects in materials and workmanship for a period of one year, except as specifically provided below. The warranty runs 12 months from the date of original installation. (End user receipt)

1. Refrigeration compressors – The warranty period is 5 years.
2. Replacement parts – The warranty period is 90 days.
3. Fry pans and coated cookware – The warranty period is 90 days
4. EverTite™ Riveting System – The warranty covers loose rivets only, forever.
5. Cayenne® Heat Strips – The warranty period is 1 year plus an additional 1 year period on heating element parts only.
6. Ultra and Professional Induction Ranges – The warranty period is 2 years.
7. Mirage and Commercial Induction ranges - The warranty period is 1 year.
8. ServeWell® Induction Workstations – The warranty period is one year on the workstation table and 2 years on induction hobs.
9. Slicers – The warranty period is 10 years on gears and 5 years on belts.
10. Mixers – The warranty period is 2 years.
11. Extended warranties are available at the time of sale.
12. Vollrath – Redco products – The warranty period is 2 years.
13. Optio / Arkadia product lines – The warranty period is 90 days.
14. All non-stick products (i.e. fry pans and surfaces) are 90 days for the non stick surfaces.

All products in the Jacob's Pride® collection, including the following, have a lifetime warranty:

- NSF Certified One-Piece Dishers
- NSF Certified Spoodle® Utensils
- NSF Certified Heavy-Duty Spoons with Ergonomic Handle
- NSF Certified Heavy-Duty Basting Spoons
- Heavy duty Turners with Ergonomic handle
- One-Piece Tongs*
- Heavy-Duty One-Piece Ladles*
- Nylon Handle Whips
- One-Piece Skimmers
- Tribute®, Intrigue®, and Classic Select® Cookware*

*Jacob's Pride® warranty does not cover Kool-Touch®, non stick coatings and silicone handles.

Items sold having no warranty:

- Meat Grinder Knives
- Light Bulbs in Convection Ovens and Hot Food Merchandiser
- Oven Door Seals
- Oven Door Glass
- Hot Food Merchandisers / Display Case Glass
- Calibration and set up of gas equipment
- Slicer / Dicer blades (table top food prep) – Redco and Vollrath

THIS WARRANTY IS IN LIEU OF ANY OTHER WARRANTIES, EXPRESS OR IMPLIED, INCLUDING ANY IMPLIED WARRANTY OF MERCHANTABILITY OR FITNESS FOR A PARTICULAR PURPOSE

As The Vollrath Company LLC's only responsibility and the purchaser's only remedy, for any breach of warranty, The Vollrath Company LLC will repair or, at its option, replace the defective product or part without charge, except as otherwise provided below:

- For refrigeration compressors and the second year of the warranty on Cayenne® Heat Strips and mixers, The Vollrath Company LLC will provide the repaired or replacement part only; and the buyer will be responsible for all labor charges incurred in performing the repair or replacement.
- To obtain warranty service, the buyer will be responsible to return to The Vollrath Company LLC any product (other than gas equipment that is permanently installed) weighing less than 110 lbs. or located outside of a 50-mile radius of a certified technician designated by The Vollrath Company LLC to perform warranty repairs. If a Vollrath Technician cannot be contacted check the website for service contact points. (Please refer to the Product Catalogue for weights and sizes of product)
- No remedy will be available for products that have been damaged by accident, carelessness, improper installation, lack of proper setup or supervision when required, neglect, improper use, installation or operation contrary to installation and operating instructions or other causes not arising out of defects in materials or workmanship. At the buyer's request, The Vollrath Company LLC will repair and or replace such products at a reasonable cost.
- No remedy will be available for slicers where blade has not been sharpened (Refer to owner's manual for sharpening instructions)
- No remedy will be available for mixers damaged by changing gears while unit is running or overloading, in either case as determined by a Vollrath Certified Technician
- Warranty work must be authorized in advance by The Vollrath Company LLC. See the operating and safety instructions for each product for detailed warranty claim procedures.
- No remedy will be available for product returned and found to be acceptable to the product specification.
- No remedy will be available under any warranty not registered as required below.

LIMITATION OF LIABILITY:

THE VOLLRATH COMPANY LLC SHALL HAVE NO LIABILITY FOR INCIDENTAL OR CONSEQUENTIAL DAMAGES OF ANY KIND, WHETHER BASED UPON NEGLIGENCE OR OTHER TORT, BREACH OF WARRANTY, OR ANY OTHER THEORY.



WARRANTY PROCEDURE

On all warranty calls, the following process and information is required:

- All warranty claims will start with a call to Vollrath Technical Service support line.(800-354-1970).
- A technical support professional will work to diagnose the issues, and provide the details for the service solution.
- Name and phone number of person calling
- Business name, street address, city, state and zip
- Model and serial number
- Date of purchase and proof of purchase (Receipt)
- Name of dealer where unit was purchased

NOTE: Vollrath will not accept products sent without the proper procedure being followed.

Important:

TO MAKE A CLAIM FOR ANY REMEDY UNDER THIS WARRANTY, YOU MUST REGISTER YOUR WARRANTY.

REGISTER TODAY

ONLINE: Register your warranty on-line now at www.Vollrathco.com

NO WEB ACCESS: If you do not have access to the web, kindly register by completing the warranty registration form and faxing it to The Vollrath Co. LLC office in the country of purchase.

WARRANTY REGISTRATION			
BUSINESS NAME _____			
KEY CONTACT NAME _____		EMAIL _____	
STREET ADDRESS _____			
CITY _____		STATE _____	ZIP CODE _____
COUNTRY _____		PHONE _____	FAX _____
MODEL _____		ITEM NUMBER _____	
SERIAL NUMBER - - 			
OPERATION TYPE			
<input type="checkbox"/> Limited Service Restaurant	<input type="checkbox"/> Full Service Restaurant	<input type="checkbox"/> Bars and Taverns	<input type="checkbox"/> Supermarket
<input type="checkbox"/> Convenience Store	<input type="checkbox"/> Recreation	<input type="checkbox"/> Hotel/Lodging	<input type="checkbox"/> Airlines
<input type="checkbox"/> Business/Industry	<input type="checkbox"/> Primary/Secondary School	<input type="checkbox"/> Colleges/University	<input type="checkbox"/> Hospitals
<input type="checkbox"/> Long-Term Care	<input type="checkbox"/> Senior Living	<input type="checkbox"/> Military	<input type="checkbox"/> Corrections
REASON FOR SELECTING OUR PRODUCT			
<input type="checkbox"/> Appearance	<input type="checkbox"/> Full Service Restaurant	<input type="checkbox"/> Availability	<input type="checkbox"/> Sellers Recommendation
<input type="checkbox"/> Ease of Operation	<input type="checkbox"/> Versatility of Use	<input type="checkbox"/> Price	<input type="checkbox"/> Brand
WOULD YOU LIKE TO RECEIVE OUR FULL-LINE CATALOG AND REMAIN ON OUR MAILING LIST?			<input type="checkbox"/> Yes <input type="checkbox"/> No

ENGLISH





www.vollrathco.com

The Vollrath Company, L.L.C.
1236 North 18th Street
Sheboygan, WI 53081-3201
U.S.A.

Main Tel: 800.628.0830
Fax: 800.752.5620

Technical Services: 800.628.0832
Service Fax: 920.459.5462

Canada Service: 800.695.8560

© 2012 The Vollrath Company, L.L.C.

