



Outperform every day.™

# Operator's Manual

## Convertible Conveyor Toasters, 300-900 Slices Per Hour\*

Models JT2HC and JT3HC

Thank you for purchasing this Vollrath equipment. Before operating the equipment, read and familiarize yourself with the following operating and safety instructions. **SAVE THESE INSTRUCTIONS FOR FUTURE REFERENCE.** Save the original box and packaging. Use this packaging to ship the equipment if repairs are needed.

### SAFETY PRECAUTIONS

To ensure safe operation, read the following statements and understand their meaning. This manual contains safety precautions which are explained below. Please read carefully.

#### **WARNING**

Warning is used to indicate the presence of a hazard that will or can cause severe personal injury or death.

#### **CAUTION**

Caution is used to indicate the presence of a hazard that will or can cause minor or major personal injury if the caution is ignored.

**NOTICE:** Notice is used to note information that is important but not hazard-related.

#### To reduce risk of injury or damage to the equipment

- Plug only into grounded electrical outlets matching the voltage on the rating plate.
- Use this equipment in a flat, level position.
- Unplug equipment and let it cool before cleaning or moving. Equipment remains hot after it is turned off.
- Do not touch during operation.
- Unplug when not in use.
- Keep equipment and power cord away from open flames, electric burners or excessive heat.
- Do not operate unattended.
- Closely supervise equipment operating in public areas and/or around children.
- Do not operate if equipment has been damaged or is malfunctioning in any way.

### FUNCTION AND PURPOSE

This equipment is intended to toast bread, bagels and sandwiches; and melt cheese. It is intended for use in commercial foodservice operations only. It is not intended for household, industrial or laboratory use.



JT2HC



JT3HC



Item No.	Model No.	Voltage	Slices Per Hour* (Up to)	Plug	
CVT4-120300	JT2HC	120	300	NEMA 5-15P	
CVT4-208550		208			
CVT4-220550		220			
CVT4-240550		240			
CVT4-23055002		230			Schuko
CVT4-23055003					
CVT4-208900	JT3HC	208	900	NEMA 6-30P	
CVT4-220900		220			
CVT4-240900		240			
CVT4-230900		230			Stripped Ends

\* Slices per hour is based on maximum conveyor speed. Conveyor speed determines toasting time and affects color and texture of the toast. Results may vary based upon type of bread, color and texture preference.

### CLEARANCE AND ENVIRONMENT REQUIREMENTS

Do not place on surfaces or near walls, partitions or kitchen furniture unless they are made of non-combustible material or clad with non-combustible heat-insulating material. Toasters must not be used near or below curtains and other combustible materials.

Do not place the toaster adjacent to a heat producing appliance.

Register your product at [Vollrath.com/registration](http://Vollrath.com/registration) and become eligible to win a free 10" Vollrath Tribute® fry pan.

## SET UP

### Install the Collection Pan

1. Place the toaster on a hard, flat, stable surface.
2. Turn the toaster on it's side with the bottom facing you.
3. Install the collection pan by placing the back edge of the pan on the lip at the back of the toaster. Line up the hole in the pan with the screw. Tighten the screw to secure the collection pan.

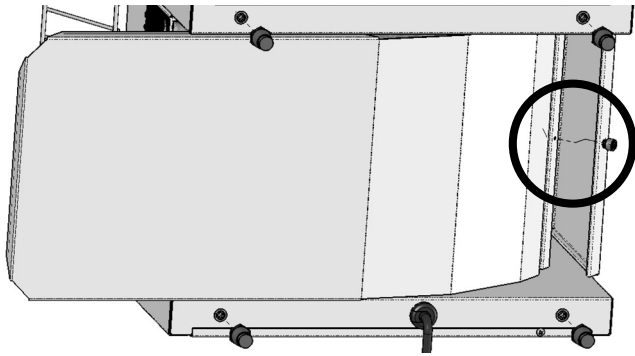

### Install the Feed Ramp

1. Position the tray so that the opening lines up with the studs.

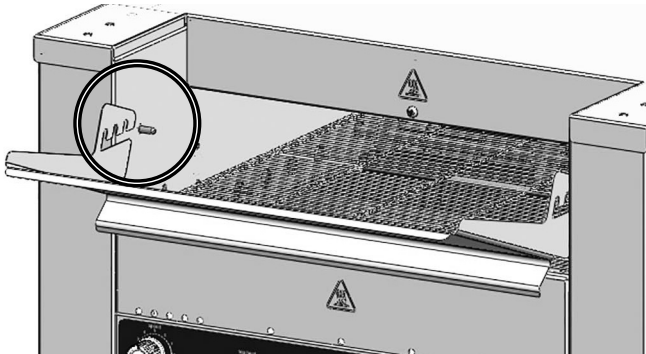

2. Rest tray on studs in desired location.

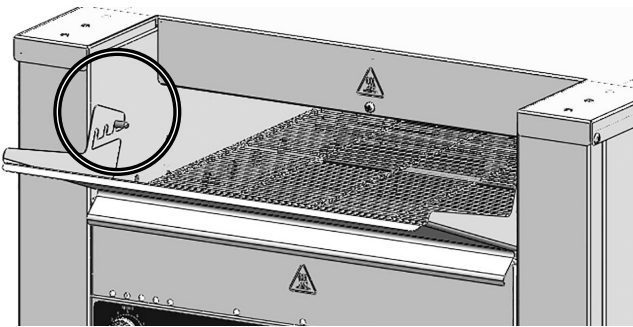

## FEATURES

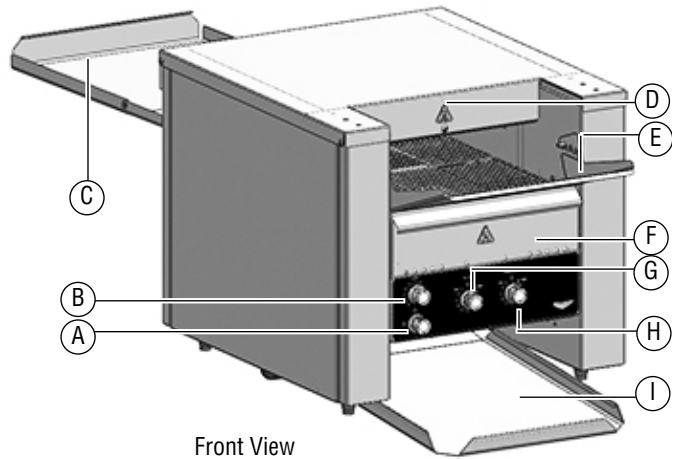

Front View

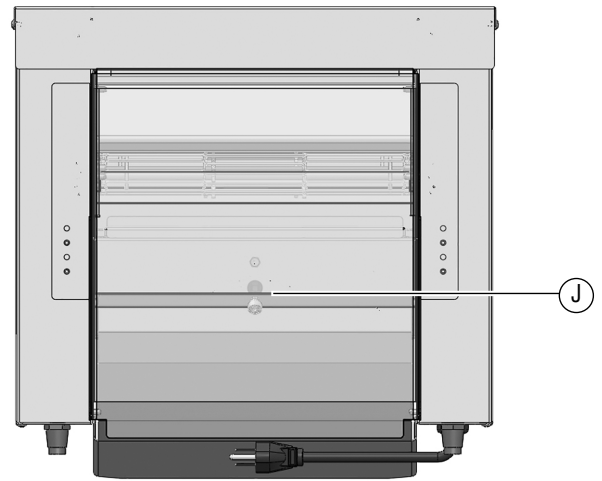

Back View

#### A Power Knob

- | Full Power - maximum heat
- Off
- ⦿ Standby - reduces electrical consumption by 75%.

#### B Conveyor Speed Control Knob

#### C Unload Tray/Back Panel

#### D Heat Shield

#### E Feed Ramp

#### F Crumb Tray

#### G Top Heat Control Knob

#### H Bottom Heat Control Knob

#### I Collection Pan

#### J Reset Button (Reference only. Access is via the front of the toasters. See page 5.)

---

## BEFORE FIRST USE

---

1. Clean the toaster. See “Cleaning” on page 5.

---

## OPERATION

---

This toaster ships set up to toast bread. To toast sandwiches, see See “Convert to A Pass through Toaster” on page 4.

	<b>CAUTION</b> <b>Burn Hazard</b> Do not touch the equipment while it is heating or operating. Hot surfaces can burn skin.
---	--

**NOTICE: The crumb tray must be installed in the toaster during operation. Failure to install the crumb tray will cause the toaster to overheat.**

### Adjust the Heat Shield

Excess space above the product will create heat loss and may reduce performance.

1. When the equipment is cool to the touch, use a screwdriver to loosen the screw on the heat shield.
2. Grasp the shield and pull it up or down to adjust the opening so the tallest products can pass through. Re-tighten the screw.

### Preheat

1. Plug the toaster into a grounded electrical outlet that matches the rating on the name plate found on the side of the toaster.

**NOTICE: Using a voltage other than the nameplate rated voltage will cause damage to the unit. Incorrect voltage, modification to the power cord or electrical components can damage unit and will void the warranty.**

2. Rotate the power knob(s) to the full power position (I).
3. Set the conveyor speed control knob(s) to 7.
4. Rotate the top and bottom heat control knobs to high.
5. Wait 5 minutes for the toaster to preheat.

### Test

1. Adjust the settings for the product to be toasted.

### Tips

Product	Suggestions
Bagels, wheat or rye bread or products with high moisture content.	Use a slower conveyor speed.
Buttered or coated, such as pastries	Not recommended.
Frozen	Must be thawed before toasting.
Sandwiches	Use slower conveyor speed to allow protein ingredients to heat. Set bottom heat control low.

2. Test the settings by placing a sample of the food to be toasted onto the feed ramp. Place bagels or buns onto the feed ramp with the cut side facing up.

### For One-Sided Toasting

TOP heat control to the desired setting.  
BOTTOM heat control to the OFF position.

3. Evaluate the results.

### Toast Bread or Sandwiches

1. Adjust the top and bottom heat control settings and conveyor as needed for even toasting. Allow time for the toaster to adjust to new heat settings before placing bread or sandwiches on the conveyor.
2. For best performance do not overload the toaster. Wait a few seconds before loading a second row of bread or sandwiches into the toaster.

### If an Item Becomes Stuck

1. Rotate the power knob to the OFF position (O) and unplug the toaster.
2. Let the toaster cool completely. Use tongs to remove the item. Take care to not bump the heating elements above and below the conveyor.

## CONVERT TO A PASS THROUGH TOASTER

1. Position the toaster so you have access to the unload tray/back panel.

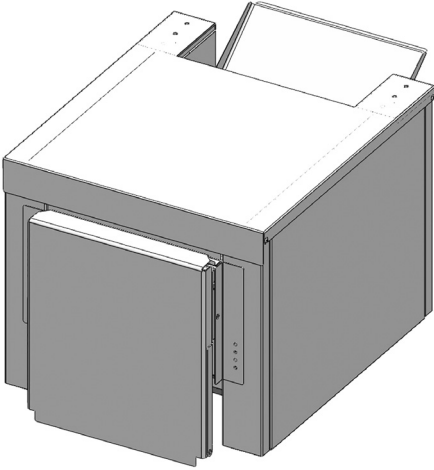

2. Lift the unload tray straight up and tilt outward as shown below.

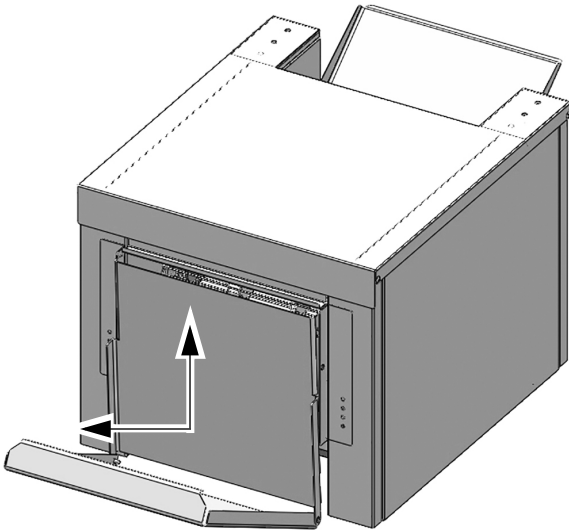

3. Note the tabs on the underside of the back panel. Clip the tabs over the two metal pins under the edges of the panel.

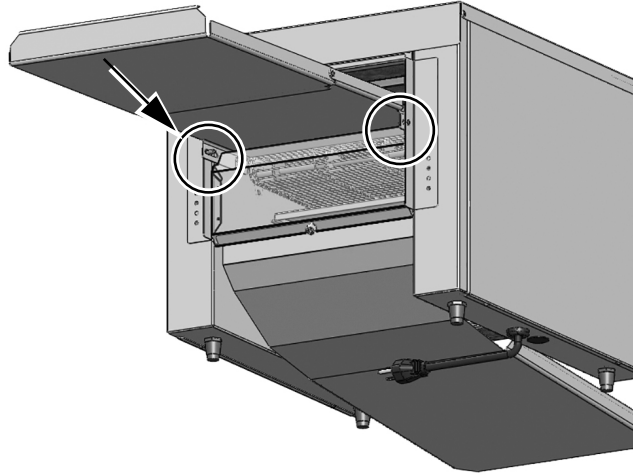

4. Drop the unload tray into the horizontal position.

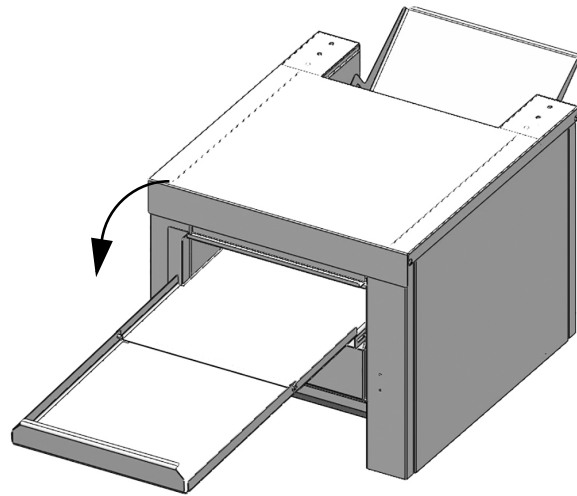

---

## CLEANING

---



### WARNING

#### Electrical Shock Hazard

Do not spray water or cleaning products. Liquid could contact the electrical components and cause a short circuit or an electrical shock.



### CAUTION

#### Burn Hazard

Allow equipment to cool before moving or cleaning.

**NOTICE:** Do not use abrasive materials, scratching cleansers or scouring pads to clean the exterior of the equipment. These can damage the finish.

**NOTICE:** Heating elements do not need to be cleaned. Crumbs and food debris will burn off. Over time the heating elements may develop a chalky appearance, but this will not impact performance.

### Daily Cleaning

1. Before turning off the equipment and with the conveyor rotating, watch the conveyor belt for food debris.
2. When the food debris reaches the front of the conveyor, rotate the power knob to the OFF position.
3. Wait for the fan to stop running. Unplug the equipment.
4. Let the equipment cool completely.
5. When the equipment is cool, use a brush or scrub pad to remove the food debris.
6. To clean the exterior, use a soft cloth dipped in hot soapy water to wipe the exterior and fan air intake under the equipment. If needed, wipe the fan intake area with degreaser to prevent long term build up.
7. Empty and clean the crumb tray(s).

---

## PREVENTATIVE MAINTENANCE

---

Contact an authorized service agent for a professional cleaning of the components.

## TROUBLESHOOTING

Problem	Might be Caused By	Course of Action
Toaster does not heat and the conveyor belt does not move.	Toaster is not plugged in.	Plug in the toaster.
	Power knob setting is incorrect.	Rotate the power knob to the ON (I) position.
	The wall breaker may be tripped.	<ol style="list-style-type: none"> <li>1. Inspect for tripped breaker.</li> <li>2. Reset the breaker.</li> <li>3. If the breaker was not tripped, inspect the toasting chamber for broken heat element tubes</li> </ol> For broken tubes, contact Vollrath Technical Services.
	The reset may be tripped.	<ol style="list-style-type: none"> <li>1. Look under the toaster to see if an object is preventing the fan blades from turning.</li> <li>1. Rotate the heat control knobs to the OFF position.</li> <li>2. Rotate the power knob to the OFF (O) position.</li> <li>3. Unplug the toaster.</li> <li>4. Wait 30 minutes for the toaster cool.</li> <li>5. Remove the object.</li> <li>6. Plug in the toaster.</li> <li>7. Rotate the power knob to the ON (I) position.</li> <li>8. Press the reset button.</li> </ol>  <ol style="list-style-type: none"> <li>9. If the problem persists call Vollrath Technical Services.</li> </ol>
Inspect the fan blades to see if they are dirty.		<ol style="list-style-type: none"> <li>1. Rotate the heat control knobs to the OFF position.</li> <li>2. Rotate the power knob to the OFF (O) position.</li> <li>3. Unplug the toaster.</li> <li>4. Wait 30 minutes for the toaster cool.</li> <li>5. Clean the fan blades.</li> <li>6. Plug in the toaster.</li> <li>7. Rotate the power knob to the ON (I) position.</li> <li>8. Press the reset button.</li> <li>9. If the problem persists call Vollrath Technical Services.</li> </ol>
Toaster heats and the conveyor belt does not move.	There may be a problem with the motor/speed control or drive chain.	Contact Vollrath Technical Services.
Top or bottom heater tubes do not heat.	One or more heater tubes may have burned out.	Contact Vollrath Technical Services.
	Heat control switch may be broken.	
Toaster repeatedly overheats.	The crumb tray may not be installed.	Verify the crumb tray is installed.
	The fan may be dirty.	Verify the fan blades are clean.
	There may be a problem with the fan.	Run the toaster for 10 minutes. If the fan does not run, contact Vollrath Technical Services.
The fan is not running.	There may be a problem with the fan or the fan switch.	Run the toaster for 10 minutes. If the fan does not run, contact Vollrath Technical Services.
The toaster is turned off and the fan is running.	Normal operation. The fan turns on as needed to cool the toaster.	—

This page intentionally left blank.

---

## SERVICE AND REPAIR

---

When under warranty, repair is available for this product. To begin the process:

1. Contact Vollrath Technical Services at 1-800-309-2250. Please be ready with the item number, model number and serial number. You can find this information on the nameplate located on the side or back of the equipment. Also please provide a proof of purchase indicating the date the equipment was purchased.
2. A technical services representative will help you troubleshoot the problem over the phone.
3. If the representative determines the issue requires professional service, he or she will help you locate an authorized service center.
4. Contact the authorized service center to make arrangements for the repair. Vollrath will cover the cost to repair and/or replace defective parts within the equipment warranty period.

---

## WARRANTY STATEMENT FOR THE VOLLRATH CO. L.L.C.

---

The Vollrath Company LLC warrants the products it manufactures or distributes against defects in materials and workmanship as specifically described in our full warranty statement. In all cases, the warranty runs from the date of the end user's original purchase date found on the receipt. Any damages from improper use, abuse, modification or damage resulting from improper packaging during return shipment for warranty repair will not be covered under warranty.

The warranty does not apply to products purchased for personal, family or household use, and The Vollrath Company LLC does not offer a written warranty to purchasers for such uses.

Warrantied Parts: The warranty period is 2 years parts, 1 year labor.

Heater Tubes: The warranty period is 1 year, including labor. Heater tube glass damage is not covered by this warranty.

For complete warranty information, product registration and new product announcements, visit [www.vollrath.com](http://www.vollrath.com).

---

The Vollrath Company, L.L.C. Headquarters  
1236 North 18th Street  
Sheboygan, Wisconsin  
53081-3201 USA  
Main Tel: 800-624-2051 or 920-457-4851  
Main Fax: 800-752-5620 or 920-459-6573  
Canada Customer Service: 800-695-8560  
Tech Services: [techservicereps@vollrathco.com](mailto:techservicereps@vollrathco.com)  
[www.vollrath.com](http://www.vollrath.com)

Pujadas  
Ctra. de Castanyet,  
132 P.O. Box 121  
17430 Santa Coloma de Farners  
(Girona) – Spain  
Tel. +34 972 84 32 01  
[info@pujadas.es](mailto:info@pujadas.es)

Vollrath of China  
Vollrath Shanghai Trading Limited  
Room 201, Building A  
Xin Yi Plaza  
1618 Yi Shan Road  
Shanghai, 201103  
China, P.R.C.  
Tel: +86-21-5058-9580

Vollrath de Mexico S. de R.L. de C.V.  
Periferico Sur No. 7980 Edificio 4-E  
Col. Santa Maria Tequepexpan  
45600 Tlaquepaque, Jalisco | Mexico  
Tel: (52) 333-133-6767  
Tel: (52) 333-133-6769  
Fax: (52) 333-133-6768