



CATALOG OF REPLACEMENT PARTS



GAS CONVECTION OVENS

DGC5	ML-126614
HGC5	ML-126615
HGC5D	ML-126616
HGC5X	ML-126618
HGC5DX	ML-126619

TABLE OF CONTENTS

5	CONTROL PANELS
7	ELECTRICAL COMPONENT PANEL
9	ELECTRICAL COMPONENT PANEL
11	OVEN PANELS AND MOTOR
13	OVEN PANELS
15	CHAIN DOOR ASSEMBLY (SIMULTANEOUSLY OPENING DOORS) (PREVIOUS CONSTRUCTION)
17	CHAIN DOOR ASSEMBLY (SIMULTANEOUSLY OPENING DOORS) (CURRENT CONSTRUCTION)
19	DOOR ASSEMBLY (INDEPENDENTLY OPENING DOORS) (PREVIOUS CONSTRUCTION)
21	DOOR ASSEMBLY (INDEPENDENTLY OPENING DOORS) (CURRENT CONSTRUCTION)
23	GAS PIPING AND FLAME CHAMBER (PREVIOUS CONSTRUCTION - ROBERT SHAW USED BEFORE 3/15/05)
25	GAS PIPING AND FLAME CHAMBER (CURRENT CONSTRUCTION - WHITE ROGERS USED ON OR AFTER 3/15/05)

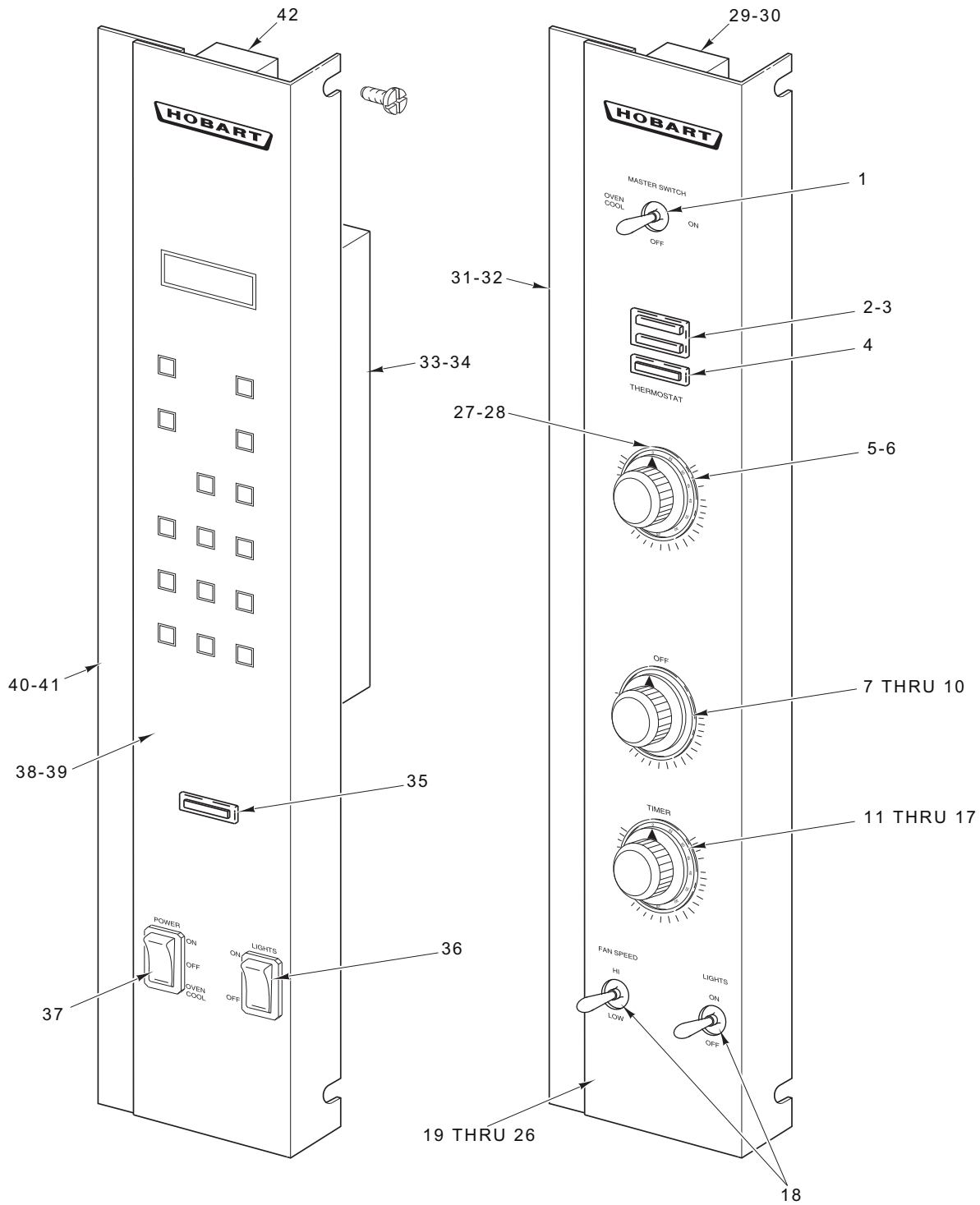

HGC5D

HGC5 / DGC5

PL-57938

CONTROL PANELS

CONTROL PANELS

ILLUS.	PART NO.	NAME OF PART	AMT.
	PL-57938		
1	00-340324-00008	Switch	1
2	00-354575-00002	Light Indicator (110-120V).....	1
3	00-354575-00001	Light Indicator (200-240 V.).....	1
4	00-354575-00004	Light – Indicator	1
5	00-411242-00001	Knob	1
6	00-353613-00002	Temperature Control Board (ML-126614, ML-126615, & ML-126618).....	1
7	00-411242-00001	Knob	1
8	00-411690-00003	Timer (120 V.) (60 Hz.) (5-Hr.)	1
9	00-411690-00004	Timer (240 V.) (60 Hz.) (5-Hr.)	1
10	00-411690-00006	Timer (240 V.) (50 Hz.) (5-Hr.).....	1
11	00-411242-00001	Knob	1
12	00-411690-00001	Timer (120 V.) (60 Hz.) (1-Hr.)	1
13	00-411690-00002	Timer (240 V.) (60 Hz.) (1-Hr.).....	1
14	00-411690-00003	Timer (120 V.) (60 Hz.) (5-Hr.)	1
15	00-411690-00004	Timer (240 V.) (60 Hz.) (5-Hr.)	1
16	00-411690-00005	Timer (240 V.) (50 Hz.) (1-Hr.)	1
17	00-411690-00006	Timer (240 V.) (50 Hz.) (5-Hr.)	1
18	00-340324-00009	Switch (D.P.D.T.).....	2
19	00-424132-00001	Overlay – Panel (ML-126614, ML-126615, & ML-126618) (1-Hr.) (Previous Construction).....	1
20	00-424238-00001	Overlay – Panel (ML-126614, ML-126615, & ML-126618) (5-Hr.) (Previous Construction).....	1
21	00-424210-00001	Overlay – Panel (ML-126614, ML-126615, & ML-126618) (1-Hr.) (Previous Construction).....	1
22	00-424247-00001	Overlay – Panel (ML-126614, ML-126615, & ML-126618) (5-Hr.) (Previous Construction).....	1
23	00-497282-00001	Overlay – Panel (ML-126614, ML-126615, & ML-126618) (1-Hr.) (Current Construction).....	1
24	00-497286-00001	Overlay – Panel (ML-126614, ML-126615, & ML-126618) (5-Hr.) (Current Construction).....	1
25	00-497287-00001	Overlay – Panel (ML-126614, ML-126615, & ML-126618) (1-Hr.) (Current Construction).....	1
26	00-497294-00001	Overlay – Panel (ML-126614, ML-126615, & ML-126618) (5-Hr.) (Current Construction).....	1
27	SC-114-82	Mach. Screw 4-40 x ⁵ / ₁₆ Rd. Hd.	2
28	WS-028-20	Washer.....	2
29	00-411499-00003	Buzzer (230 V.)	1
30	00-411499-00004	Buzzer (115 V.)	1
31	00-424206-000G1	Panel – Control Weldment (Previous Construction)	1
32	00-499596-000G1	Panel – Control Weldment (Current Construction)	1
33	NS-044-05	Nut Assy. 6-32 Hex KEPS.....	7
34	00-424846-00001	Controller (Watlow #734)	1
35	00-354575-00004	Light – Indicator	1
36	00-358628-00002	Switch – Rocker (2-Position)	1
37	00-358628-00001	Switch – Rocker (3-Position)	1
38	00-424845-00001	Overlay – Control Panel (ML-126616 & ML-126619) (Previous Construction).....	1
39	00-497288-00001	Overlay – Control Panel (ML-126616 & ML-126619) (Current Construction).....	1
40	00-424842-000G1	Panel – Control Assy. (Previous Construction).....	1
41	00-499301-000G1	Panel – Control Assy. (ML-126616 & ML-126619) (Current Construction).....	1
42	00-423918-00001	Electronic Beeper	1

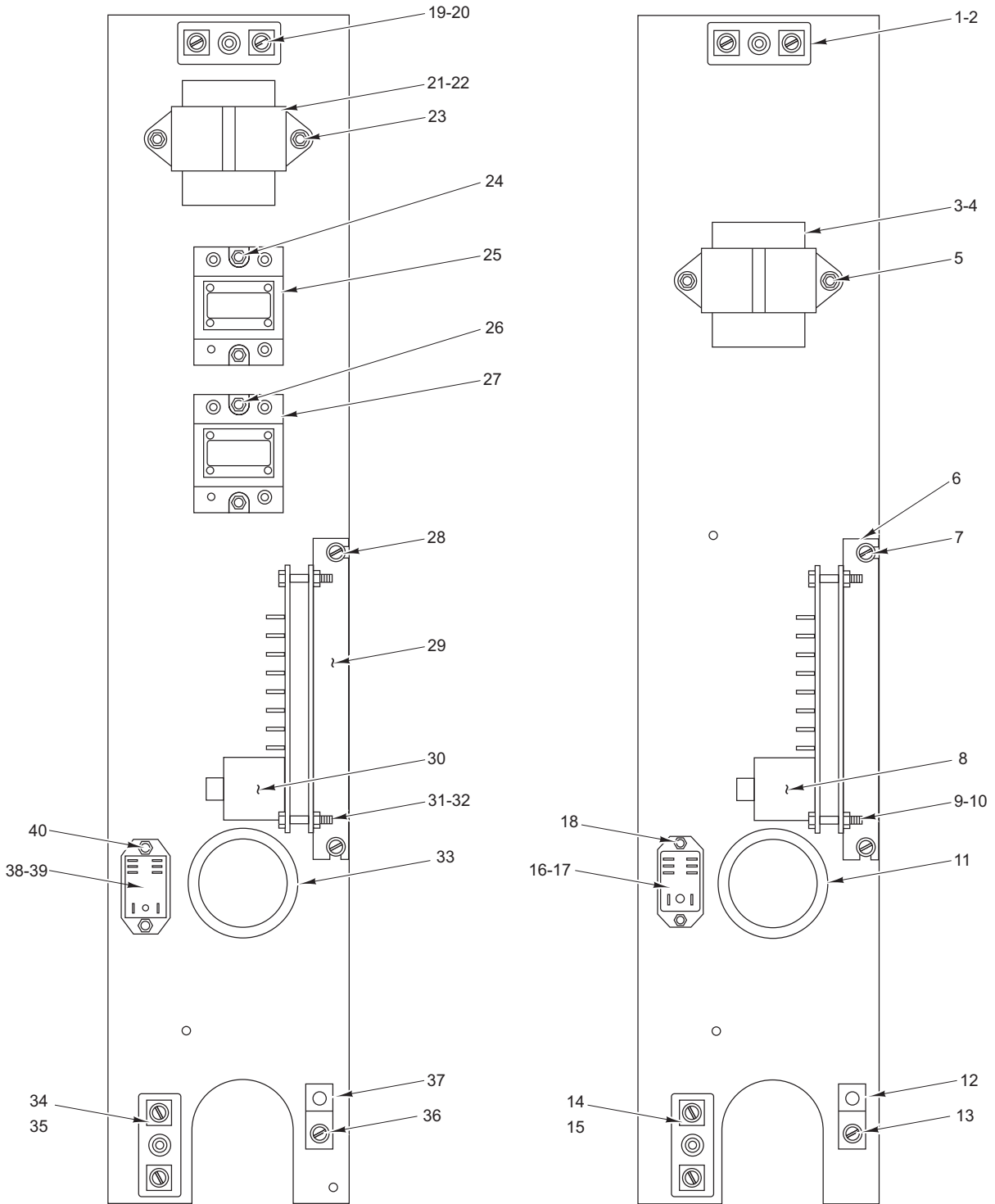

HGC5D

**HGC5 / DGC5
(W/O COOK & HOLD)**

PL-55190

ELECTRICAL COMPONENT PANEL

ELECTRICAL COMPONENT PANEL

ILLUS. PL-55190	PART NO.	NAME OF PART	AMT.
1	00-417934-000G1	Block Assy. – Porcelain.....	1
2	SD-034-52	Self-Tapping Screw 8-32 x 1 Hex Washer Hd., Type T.....	1
3	00-411500-00012	Transformer (120 V.) (24 V. Output).....	1
4	00-411500-00013	Transformer (208-240 V.) (24 V. Output).....	1
5	SD-032-07	Self-Tapping Screw 10-24 x 1/2 Hex Washer Hd., Type TT.....	2
6	00-423760-00001	Bracket – Ignition Module.....	1
7	SD-032-07	Self-Tapping Screw 10-24 x 1/2 Hex Washer Hd., Type TT.....	1
8	00-424137-00002	Control – Spark Ignition.....	1
9	SD-034-52	Self-Tapping Screw 8-32 x 1 Hex Washer Hd., Type T.....	2
10	NS-044-07	Nut Assy. 8-32 Hex KEPS.....	2
11	FE-024-23	Bushing – Electrical (Snap).....	1
12	00-417856-00001	Lug – Grounding (With Set Screw).....	1
13	SD-032-07	Self-Tapping Screw 10-24 x 1/2 Hex Washer Hd., Type TT.....	1
14	00-417934-000G1	Block Assy. – Porcelain.....	1
15	SD-034-52	Self-Tapping Screw 8-32 x 1 Hex Washer Hd., Type T.....	1
16	00-416535-00006	Relay – Heating (120 V.).....	1
17	00-416535-00007	Relay – Heating (200-240 V.).....	1
18	SD-034-49	Self-Tapping Screw 8-32 x 1/2 Hex Washer Hd., Type T.....	1
19	00-417934-000G1	Block Assy. – Porcelain.....	1
20	SD-034-52	Self-Tapping Screw 8-32 x 1 Hex Washer Hd., Type T.....	1
21	00-421758-000G1	Transformer (120 V.) (24 V. Output).....	1
22	00-421758-000G2	Transformer (208-240 V.) (24 V. Output).....	1
23	SD-032-07	Self-Tapping Screw 10-24 x 1/2 Hex Washer Hd., Type TT.....	2
24	SD-034-52	Self-Tapping Screw 8-32 x 1 Hex Washer Hd., Type T.....	4
25	00-821875-00002	Relay – Solid-State (50 Amp.).....	2
26	SD-034-52	Self-Tapping Screw 8-32 x 1 Hex Washer Hd., Type T.....	4
27	00-821875-00002	Relay – Solid-State (50 Amp.).....	2
28	SD-032-07	Self-Tapping Screw 10-24 x 1/2 Hex Washer Hd., Type TT.....	1
29	00-423760-00001	Bracket – Ignition Module.....	1
30	00-424137-00002	Control – Spark Ignition.....	1
31	SD-034-52	Self-Tapping Screw 8-32 x 1 Hex Washer Hd., Type T.....	2
32	NS-044-07	Nut Assy. 8-32 Hex KEPS.....	2
33	FE-024-23	Bushing – Electrical (Snap).....	1
34	SD-034-52	Self-Tapping Screw 8-32 x 1 Hex Washer Hd., Type T.....	1
35	00-417934-000G1	Block Assy. – Porcelain.....	1
36	SD-032-07	Self-Tapping Screw 10-24 x 1/2 Hex Washer Hd., Type TT.....	1
37	00-417856-00001	Lug – Grounding (With Set Screw).....	1
38	00-416535-00006	Relay – Heating (120 V.).....	1
39	00-416535-00007	Relay – Heating (200-240 V.).....	1
40	SD-034-49	Self-Tapping Screw 8-32 x 1/2 Hex Washer Hd., Type T.....	2
	00-353589-00001	Probe Temperature (SST) (ML-126615).....	1
	00-920883-00003	Probe Temperature (ML-126616).....	1
	00-423813-00003	Wire – Ignition (High Voltage).....	1

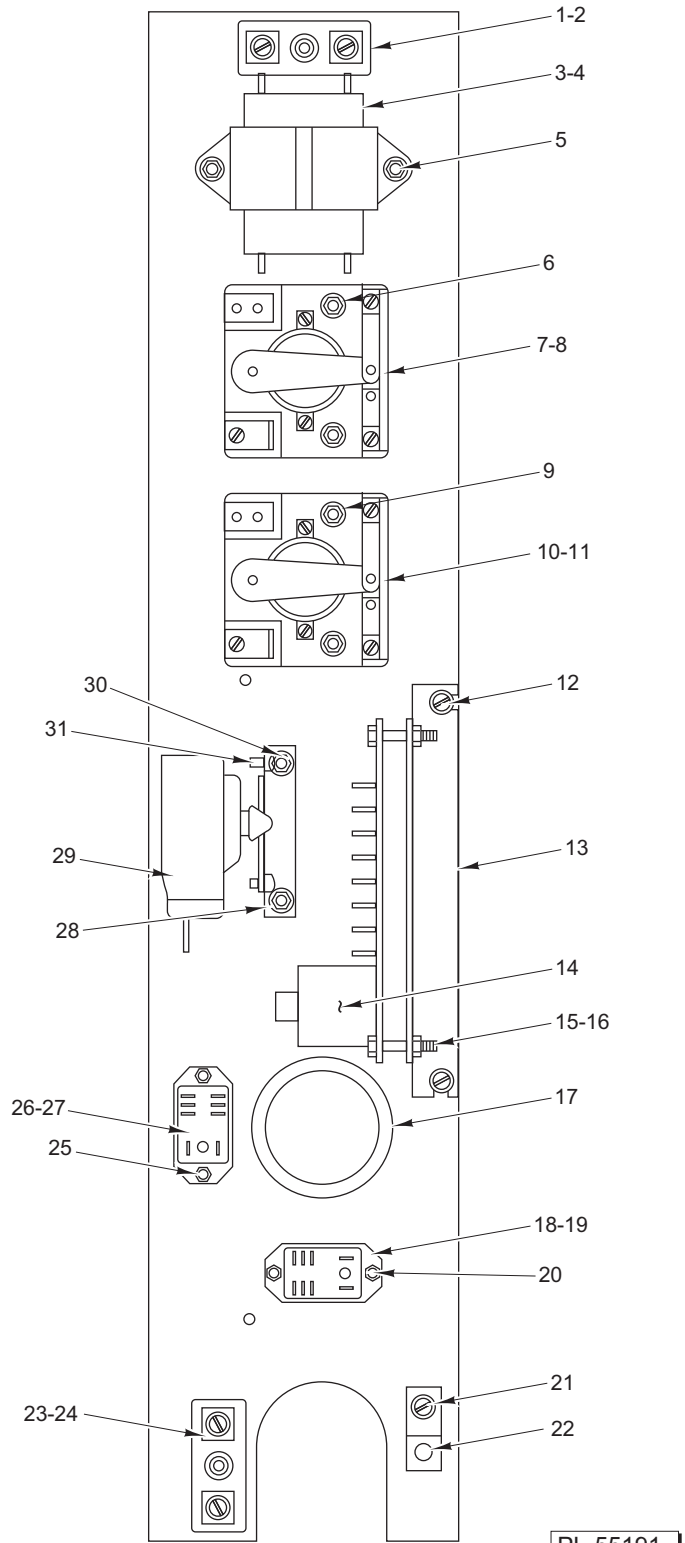

**HGC5 / DGC5
(W/COOK & HOLD)
ELECTRICAL COMPONENT PANEL**

ELECTRICAL COMPONENT PANEL

ILLUS. PL-55191	PART NO.	NAME OF PART	AMT.
1	00-417934-000G1	Block Assy. – Porcelain.....	1
2	SD-034-52	Self-Tapping Screw 8-32 x 1 Hex Washer Hd., Type T.....	1
3	00-421758-000G1	Transformer (120 V.) (24 V. Output).....	1
4	00-421758-000G2	Transformer (208-240 V.) (24 V. Output).....	1
5	SD-032-07	Self-Tapping Screw 10-24 x 1/2 Hex Washer Hd., Type TT.....	2
6	SD-034-52	Self-Tapping Screw 8-32 x 1 Hex Washer Hd., Type T.....	2
7	00-411497-000A1	Relay (1-Pole) (120 V.).....	1
8	00-411497-000A2	Relay (1-Pole) (200 V.).....	1
9	SD-034-52	Self-Tapping Screw 8-32 x 1 Hex Washer Hd., Type T.....	2
10	00-411497-000A1	Relay (1-Pole) (120 V.).....	1
11	00-411497-000A2	Relay (1-Pole) (200 V.).....	1
12	SD-032-07	Self-Tapping Screw 10-24 x 1/2 Hex Washer Hd., Type TT.....	2
13	00-423760-00001	Bracket – Ignition Module.....	1
14	00-424137-00002	Control – Spark Ignition.....	1
15	SD-034-52	Self-Tapping Screw 8-32 x 1 Hex Washer Hd., Type T.....	2
16	NS-044-07	Nut Assy. 8-32 Hex KEPS.....	2
17	FE-024-23	Bushing – Electrical (Snap).....	1
18	00-416535-00006	Relay – Heating (120 V.) (ML-126614).....	1
19	00-416535-00007	Relay – Heating (200-240 V.) (ML-126614).....	1
20	SD-034-49	Self-Tapping Screw 8-32 x 1/2 Hex Washer Hd., Type T.....	2
21	SD-032-07	Self-Tapping Screw 10-24 x 1/2 Hex Washer Hd., Type TT.....	1
22	00-417856-00001	Lug – Grounding (With Set Screw).....	1
23	00-417934-000G1	Block Assy. – Porcelain.....	1
24	SD-034-52	Self-Tapping Screw 8-32 x 1 Hex Washer Hd., Type T.....	1
25	SD-034-49	Self-Tapping Screw 8-32 x 1/2 Hex Washer Hd., Type T.....	2
26	00-416535-00006	Relay – Heating (120 V.).....	1
27	00-416535-00007	Relay – Heating (200-240 V.).....	1
28	00-424832-00001	Bracket – Mounting.....	1
29	00-413764-00001	Thermostat.....	1
30	SD-032-07	Self-Tapping Screw 10-24 x 1/2 Hex Washer Hd., Type TT.....	2
31	SC-114-83	Mach. Screw 6-32 x 1/4 Pan Hd.....	2
	00-353589-00001	Probe Temperature (SST) (ML-126615).....	1

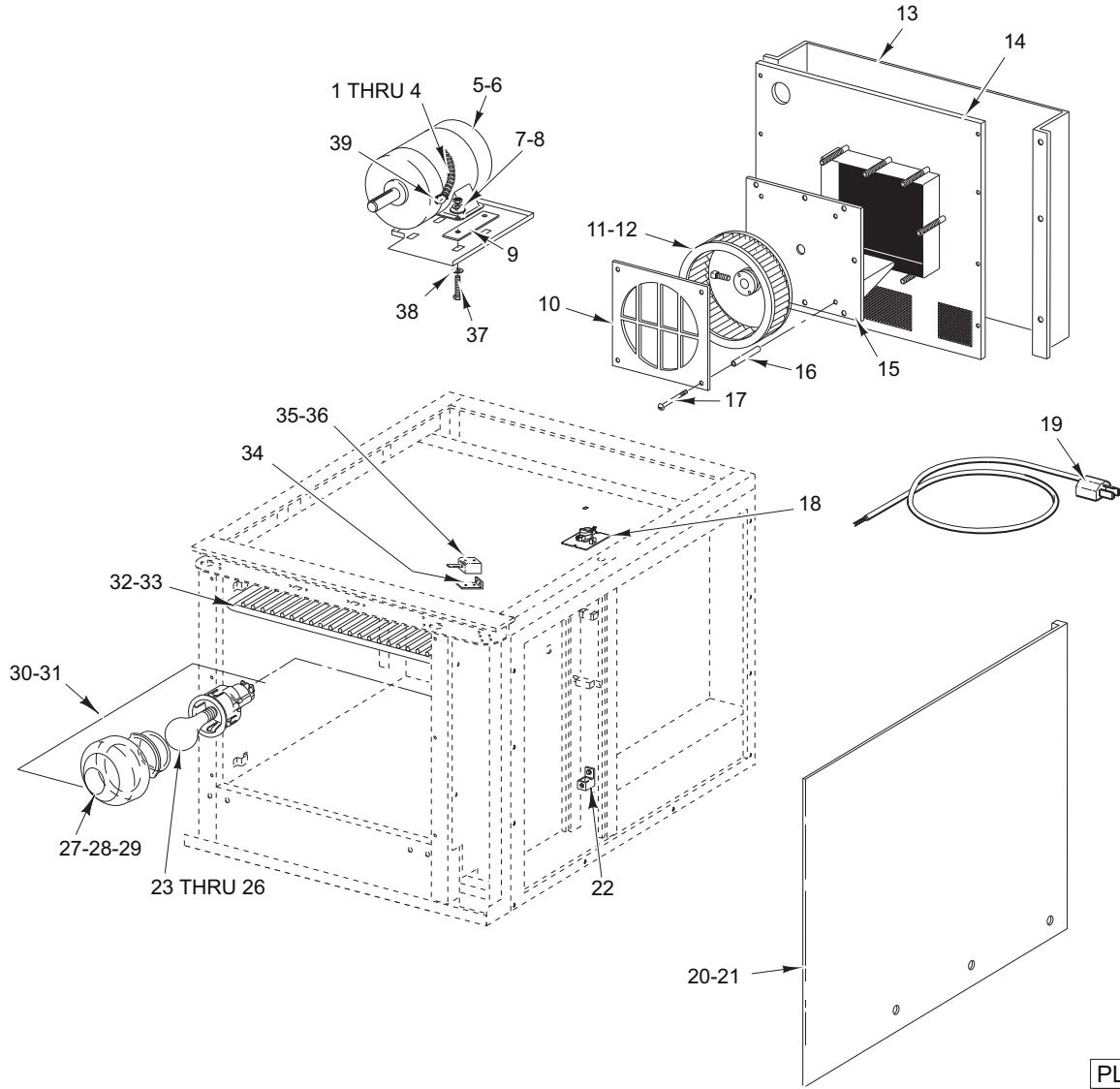

PL-57935

OVEN PANELS AND MOTOR

OVEN PANELS AND MOTOR

ILLUS.	PART NO.	NAME OF PART	AMT.
PL-57935			
1	FE-006-05	Lock Nut 1/2	1
2	00-414540-00B35	Conduit 3/8 x 35 In. Lg.	1
3	00-342285-00001	Bushing – Plastic	2
4	FE-002-03	Connector – Conduit 3/8 TS Straight.....	1
5	00-358516-00001	Motor 1/2 Hp. (2-Speed) (115 V., 50/60 Hz., 1 Ph.).....	1
6	00-358516-00002	Motor 1/2 Hp. (2-Speed) (208-240 V., 50/60 Hz., 1 Ph.).....	1
7	WS-029-46	Washer.....	4
8	NS-046-86	Nut Assy. 5/16 -18 KEPS Hex	4
9	00-358723-00001	Spacer – Steel	2
10	00-411136-00004	Fan – Cover	1
11	00-415780-00003	Wheel – Blower (60 Hz.).....	1
12	00-415780-00005	Wheel – Blower (50 Hz.).....	1
13	00-424840-00002	Panel – Back (SST) (Optional)	1
14	00-424153-000G1	Panel Assy. – Back	1
15	00-423289-000G1	Motor Mount.....	1
16	00-411289-00004	Spacer – Fan Housing	4
17	SC-120-15	Mach. Screw 1/4-20 x 4 Rd. Hd.....	4
18	00-346358-00002	Plate Assy. (Incls. High Limit).....	1
19	00-405016-00001	Cord – Electric Supply (120 V. Only)	1
20	00-424140-00002	Panel – Outer (RH) (SST) (ML-126614, ML-126615, & ML-126616)	1
21	00-424228-00002	Panel – Outer (RH) (SST) (ML-126618 & ML-126619)	1
22	00-417856-00001	Lug – Grounding (With Set Screw).....	1
23	00-342766-00001	Lamp – Oven (40 Watts) (240 V.) (Previous Construction).....	1
24	00-357036-00001	Lamp – Oven (40 Watts) (120-130 V.) (Current Construction).....	1
25	00-342766-00002	Light Bulb – Oven (40 Watts) (240 V.) (Previous Construction).....	1
26	00-357036-00002	Lamp – Oven (40 Watts) (250 V.) (Current Construction).....	1
27	00-423832-00001	Cover – Light (Previous Construction).....	2
28	00-428595-00001	Cover – Light (Current Construction).....	1
29	00-357036-00003	Lens – Lamp	1
30	00-357036-00001	Oven Lamp (40 Watts) (120-130 V.).....	2
31	00-357036-00002	Oven Lamp (40 Watts) (250 V.)	2
32	00-411265-00011	Rack Assy. (ML-126614, ML-126615, & ML-126616).....	AR
33	00-411265-00010	Rack Assy. (ML-126618 & ML-126619)	AR
34	00-425324-00001	Bracket – Door Switch	1
35	00-411496-000F1	Switch – Micro	1
36	SD-034-47	Self-Tapping Screw 6-32 x 1 Hex Washer Hd., Type T.....	2
37	SC-113-65	Cap Screw 5/16-18 x 1 1/4 Hex Hd.....	4
38	WS-029-46	Washer.....	4
39	FE-002-52	Connector – Conduit 3/8 TS (90 Deg.).....	1
	00-427617-00001	Flue – Deflector	1
	00-413627-000G1	Tube – Snorkel Assembly	1
	00-402558-00004	Clip – Bulb	2

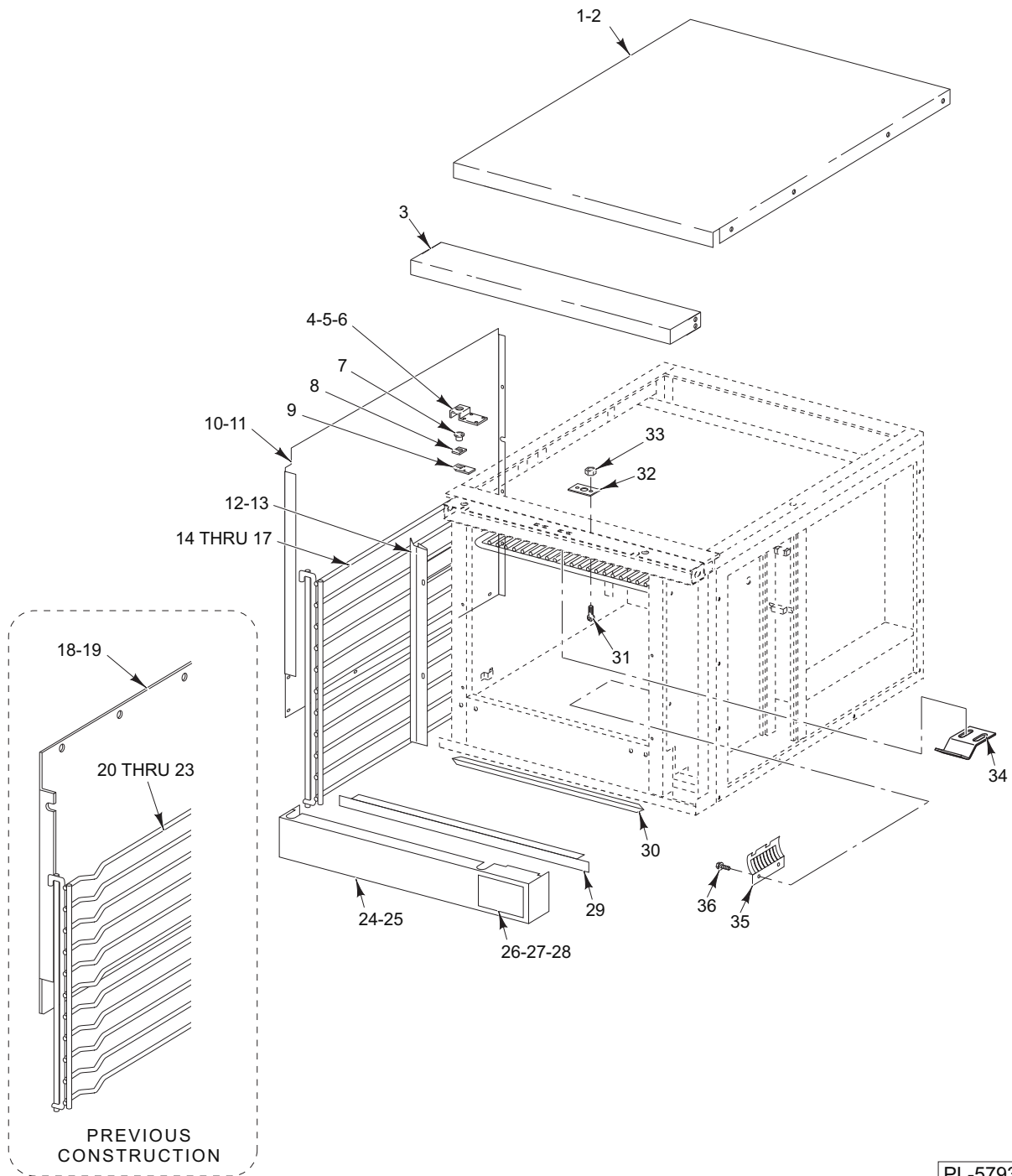

PL-57939

OVEN PANELS

OVEN PANELS

ILLUS.	PART NO.	NAME OF PART	AMT.
PL-57939			
1	00-424141-00002	Top (SST) (ML-126614, ML-126615, & ML-126616)	1
2	00-424229-00002	Top (SST) (ML-126618 & ML-126619)	1
3	00-421799-00001	Top – Front.....	1
4	00-353484-00001	Plate – Retainer.....	2
5	SC-053-41	Mach. Screw 1/4-20 x 1/2 Truss Hd. (SST).....	4
6	NS-038-08	Lock Nut 1/4-20 x 1 Hex.....	4
7	00-347080-00002	Bearing – Door Shaft.....	2
8	00-353482-00001	Spacer.....	2
9	00-353483-00001	Plate – Upper Door Bearing.....	2
10	00-424142-00002	Panel – Outer (SST) (LH) (ML-126614, ML-126615, & ML-126616) (Previous Construction) ..	1
11	00-424230-00002	Panel – Outer (SST) (LH) (ML-126618 & ML-126619) (Previous Construction)	1
12	00-499302-00001	Side – Left Body (ML-126614, ML-126615, & ML-126616) (Current Construction)	1
13	00-499303-00001	Side – Left Body (ML-126618 & ML-126619) (Current Construction).....	1
14	00-428104-00001	Rack – Guide (LH) (ML-126614, ML-126615, & ML-126616) (Current Construction)	1
15	00-428104-00002	Rack – Guide (RH) (ML-126614, ML-126615, & ML-126616) (Current Construction)	1
16	00-428104-00003	Rack – Guide (LH) (ML-126618 & ML-126619) (Current Construction)	1
17	00-428104-00004	Rack – Guide (RH) (ML-126618 & ML-126619) (Current Construction).....	1
18	00-423842-000G1	Seal – Vertical Door (Set) (LH & RH).....	1
19	00-357919-00001	Kit – Door Seal (Incls. Items 18 & 30).....	1
20	00-342141-00001	Rack – Support (LH) (ML-126614, ML-126615, & ML-126616) (Previous Construction).....	1
21	00-342141-00002	Rack – Support (RH) (ML-126614, ML-126615, & ML-126616) (Previous Construction)	1
22	00-424833-00001	Rack – Support (LH) (ML-126618 & ML-126619) (Previous Construction)	1
23	00-424833-00002	Rack – Support (RH) (ML-126618 & ML-126619) (Previous Construction).....	1
24	00-423766-000G1	Trim – Bottom W/Access Door Assy. (Previous Construction).....	1
25	00-499261-00002	Trim – Bottom W/O Access Door Assy. (Current Construction)	1
26	00-423758-00001	Door – Access Trim (Previous Construction)	1
27	00-499297-00001	Door – Lower Access Trim (Current Construction)	1
28	00-425199-00001	Fastener – Nylon Push-In	2
29	00-424865-00001	Cover – Trim	1
30	00-357507-00001	Seal – Horizontal Door.....	2
31	SC-115-51	Mach. Screw 10-32 x 1/2 Phil. Truss Hd.	2
32	00-423848-00001	Shim – Door Strike.....	AR
33	NS-038-03	Lock Nut – SP 10-32.....	2
34	00-497585-00001	Plate – Strike	1
35	00-499278-00001	Guard – Probe	1
36	SD-032-07	Self-Tapping Screw 10-24 x 1/2 Hex Washer Hd., Type TT	2

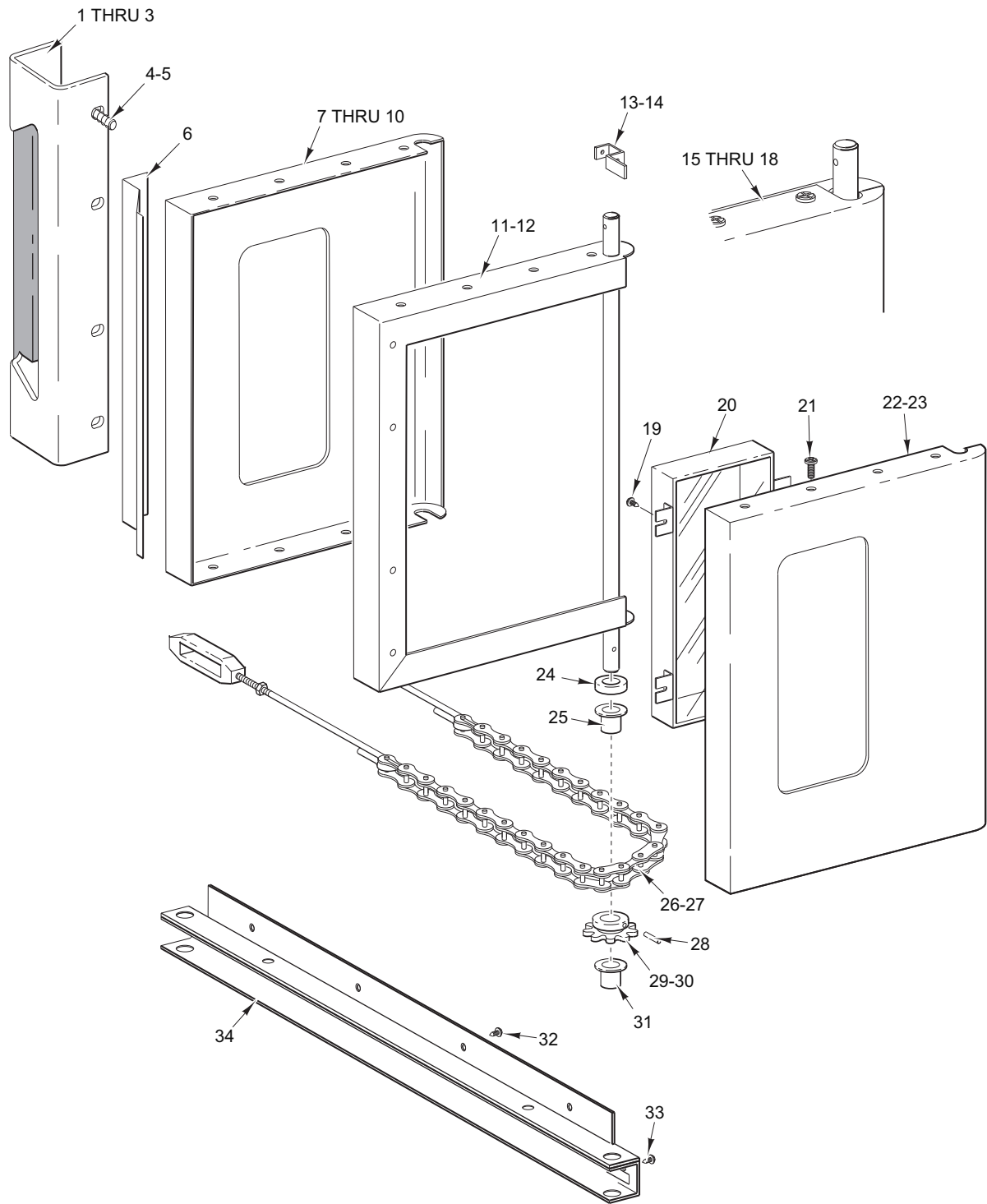

PL-57936

**CHAIN DOOR ASSEMBLY
(SIMULTANEOUSLY OPENING DOORS) (PREVIOUS CONSTRUCTION)**

**CHAIN DOOR ASSEMBLY
(SIMULTANEOUSLY OPENING DOORS) (PREVIOUS CONSTRUCTION)**

ILLUS. PL-57936	PART NO.	NAME OF PART	AMT.
1	00-356562-00001	Handle – Door.....	1
2	00-421923-000G1	Grip – Set.....	1
3	SC-113-98	Mach. Screw 10-24 x 1/2 Hex Washer Hd.	3
4	SC-041-01	Cap Screw 1/4-20 x 3/4 Hex Hd. (SST)	4
5	WL-019-18	Lockwasher 1/4 Light.....	4
6	00-356550-00001	Latch – Friction	1
7	00-421913-00002	Panel – Outer Door (RH) (W/O Window).....	1
8	00-421913-00003	Panel – Outer Door (LH) (W/Window)	1
9	00-421913-00001	Panel – Outer Door (RH) (W/Window).....	1
10	00-421913-00004	Panel – Outer Door (RH) (W/O Window).....	1
11	00-421904-000G2	Frame Assy. – Door (LH)	1
12	00-421905-000G1	Frame Assy. – Door (RH).....	1
13	00-424163-00001	Lever – Door Switch	1
14	SD-034-52	Self-Tapping Screw 8-32 x 1 Hex Washer Hd., Type T.....	1
15	00-424730-00001	Door Assy. (LH) (W/Window)	1
16	00-424730-00002	Door Assy. (LH) (W/O Window)	1
17	00-424731-00001	Door Assy. (RH) (W/Window).....	1
18	00-424731-00002	Door Assy. (RH) (W/O Window).....	1
19	SD-034-62	Self-Tapping Screw 10-32 x 1/2 Hex Washer Hd., Type T	4
20	00-358534-00001	Window Assy.....	1
21	SD-034-22	Self-Tapping Screw 10-16 X 5/8 Phil. Truss Hd., Type AB	9
22	00-358532-00001	Panel – Inner Door (W/Window)	1
23	00-358533-00003	Panel – Inner Door (W/O Window)	1
24	00-343143-00002	Washer.....	2
25	00-347080-00002	Bearing – Door Shaft	2
26	00-343608-00002	Door Chain & Turnbuckle Assy.	2
27	00-352667-00001	Cable – Door Stop	1
28	PS-004-11	Spirol Pin 3/16 x 1 1/4 Heavy	2
29	00-342166-00001	Sprocket – Door Shaft	2
30	SC-047-28	Set Screw 1/4-28 x 3/8 Hex Hdls., Cup Pt.	2
31	00-347080-00002	Bearing – Door Shaft	2
32	SC-022-40	Mach. Screw 1/4-20 x 3/4 Phil. Flat Hd.....	4
33	SC-113-90	Mach. Screw 1/4-20 x 3/4 Hex Hd.	2
34	00-357846-00001	Channel – Door Sill Weldment.....	1

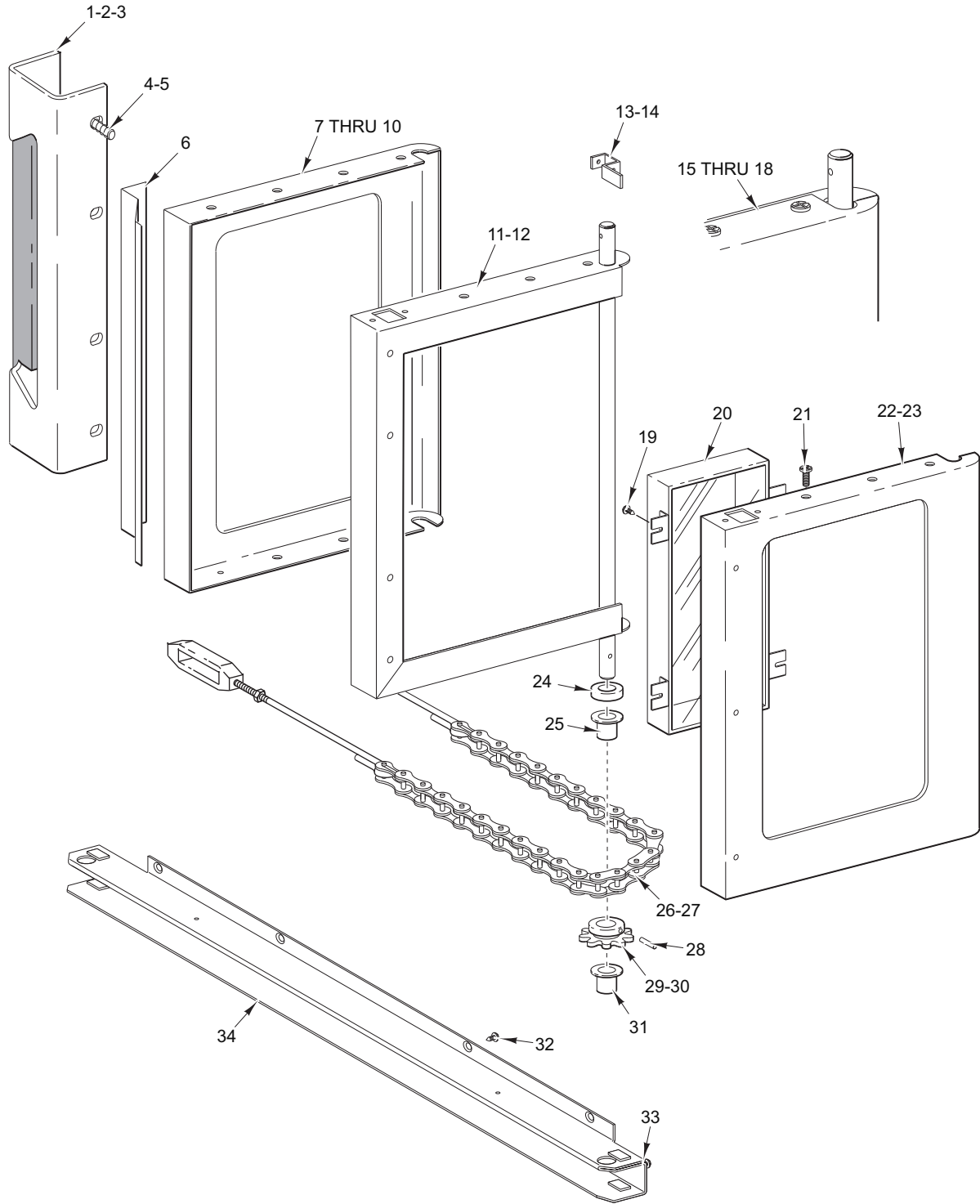

PL-58628

**CHAIN DOOR ASSEMBLY
(SIMULTANEOUSLY OPENING DOORS) (CURRENT CONSTRUCTION)**

**CHAIN DOOR ASSEMBLY
(SIMULTANEOUSLY OPENING DOORS) (CURRENT CONSTRUCTION)**

ILLUS. PL-58628	PART NO.	NAME OF PART	AMT.
1	00-356562-00001	Handle – Door.....	1
2	00-421923-000G1	Grip – Set.....	1
3	SC-113-98	Mach. Screw 10-24 x 1/2 Hex Washer Hd.	3
4	SC-041-01	Cap Screw 1/4-20 x 3/4 Hex Hd. (SST)	4
5	WL-019-18	Lockwasher 1/4 Light.....	4
6	00-356550-00001	Latch – Friction	1
7	00-421913-00002	Panel – Outer Door (RH) (W/O Window).....	1
8	00-421913-00003	Panel – Outer Door (LH) (W/Window).....	1
9	00-421913-00001	Panel – Outer Door (RH) (W/Window).....	1
10	00-421913-00004	Panel – Outer Door (RH) (W/O Window).....	1
11	00-421904-000G2	Frame Assy. – Door (LH)	1
12	00-421905-000G1	Frame Assy. – Door (RH).....	1
13	00-424163-00001	Lever – Door Switch	1
14	SD-034-52	Self-Tapping Screw 8-32 x 1 Hex Washer Hd., Type T.....	1
15	00-499289-000G1	Door Assy. (LH) (W/Window).....	1
16	00-499289-000G2	Door Assy. (LH) (W/O Window)	1
17	00-499290-000G1	Door Assy. (RH) (W/Window).....	1
18	00-499290-000G2	Door Assy. (RH) (W/O Window).....	1
19	SD-034-62	Self-Tapping Screw 10-32 x 1/2 Hex Washer Hd., Type T	4
20	00-358534-00001	Window Assy.....	1
21	SD-034-22	Self-Tapping Screw 10-16 X 5/8 Phil. Truss Hd., Type AB.....	9
22	00-358532-00001	Panel – Inner Door (W/Window).....	1
23	00-358533-00003	Panel – Inner Door (W/O Window)	1
24	00-343143-00002	Washer.....	2
25	00-347080-00002	Bearing – Door Shaft	2
26	00-343608-00002	Door Chain & Turnbuckle Assy.	2
27	00-352667-00001	Cable – Door Stop	1
28	PS-004-11	Spirol Pin 3/16 x 1 1/4 Heavy.....	2
29	00-342166-00001	Sprocket – Door Shaft	2
30	SC-047-28	Set Screw 1/4-28 x 3/8 Hex Hdls., Cup Pt.	2
31	00-347080-00002	Bearing – Door Shaft	2
32	SC-022-40	Mach. Screw 1/4-20 x 3/4 Phil. Flat Hd.....	4
33	SC-113-90	Mach. Screw 1/4-20 x 3/4 Hex Hd.	2
34	00-499300-000G1	Channel – Bottom Door Sill	1

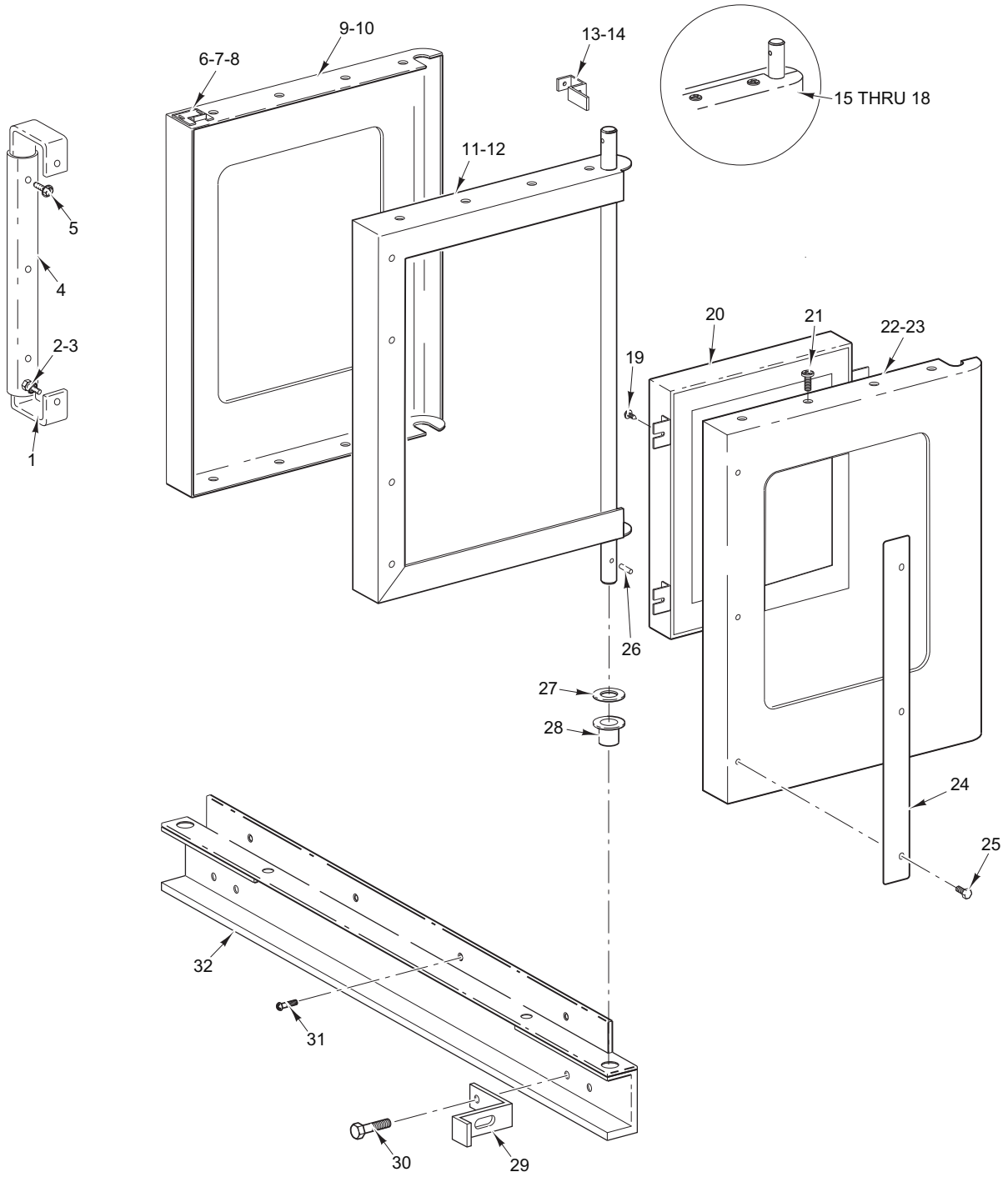

PL-57937

**DOOR ASSEMBLY
(INDEPENDENTLY OPENING DOORS) (PREVIOUS CONSTRUCTION)**

**DOOR ASSEMBLY
(INDEPENDENTLY OPENING DOORS) (PREVIOUS CONSTRUCTION)**

ILLUS. PL-57937	PART NO.	NAME OF PART	AMT.
1	00-357929-00001	Handle Assy. – Door	1
2	SC-041-01	Cap Screw 1/4-20 x 3/4 Hex Hd. (SST)	2
3	WL-019-37	Lockwasher 1/4 Internal	2
4	00-421923-000G1	Grip – Set.....	1
5	SC-113-98	Mach. Screw 10-24 x 1/2 Hex Washer Hd.	3
6	00-423847-00001	Strike – Door.....	1
7	SD-034-22	Self-Tapping Screw 10-16 X 5/8 Phil. Truss Hd., Type AB	2
8	WL-019-35	Lockwasher #10 Internal.....	2
9	00-358600-00001	Panel – Outer Door (RH) (W/Window).....	1
10	00-358600-00002	Panel – Outer Door (RH) (W/O Window).....	1
11	00-421905-000G1	Frame Assy. – Door (RH).....	1
12	00-421904-000G2	Frame Assy. – Door (LH)	1
13	00-424163-00001	Lever – Door Switch	1
14	SD-034-52	Self-Tapping Screw 8-32 x 1 Hex Washer Hd., Type T.....	1
15	00-358529-00005	Door Assy. (LH) (W/Window)	1
16	00-358529-00006	Door Assy. (LH) (W/O Window)	1
17	00-358530-00003	Door Assy. (RH) (W/Window).....	1
18	00-358530-00004	Door Assy. (RH) (W/O Window).....	1
19	SD-034-62	Self-Tapping Screw 10-32 x 1/2 Hex Washer Hd., Type T	4
20	00-358534-00001	Window Assy.....	1
21	00-350543-00006	Mach. Screw 10-32 x 1/2 Phil. Pan Hd.....	8
22	00-358532-00001	Panel – Inner Door (W/Window)	1
23	00-358533-00003	Panel – Inner Door (W/O Window)	1
24	00-357837	Seal – Door End	1
25	SD-034-22	Self-Tapping Screw 10-16 X 5/8 Phil. Truss Hd., Type AB	3
26	PS-004-11	Spirol Pin 3/16 x 1 1/4 Heavy	1
27	00-343143-00002	Washer.....	2
28	00-347080-00002	Bearing – Door Shaft	1
29	00-424158-00001	Door Stop.....	1
30	SC-113-90	Mach. Screw 1/4-20 x 3/4 Hex Hd.	2
31	SC-022-40	Mach. Screw 1/4-20 x 3/4 Phil. Flat Hd.....	4
32	00-357846-00001	Channel – Door Sill Weldment.....	1

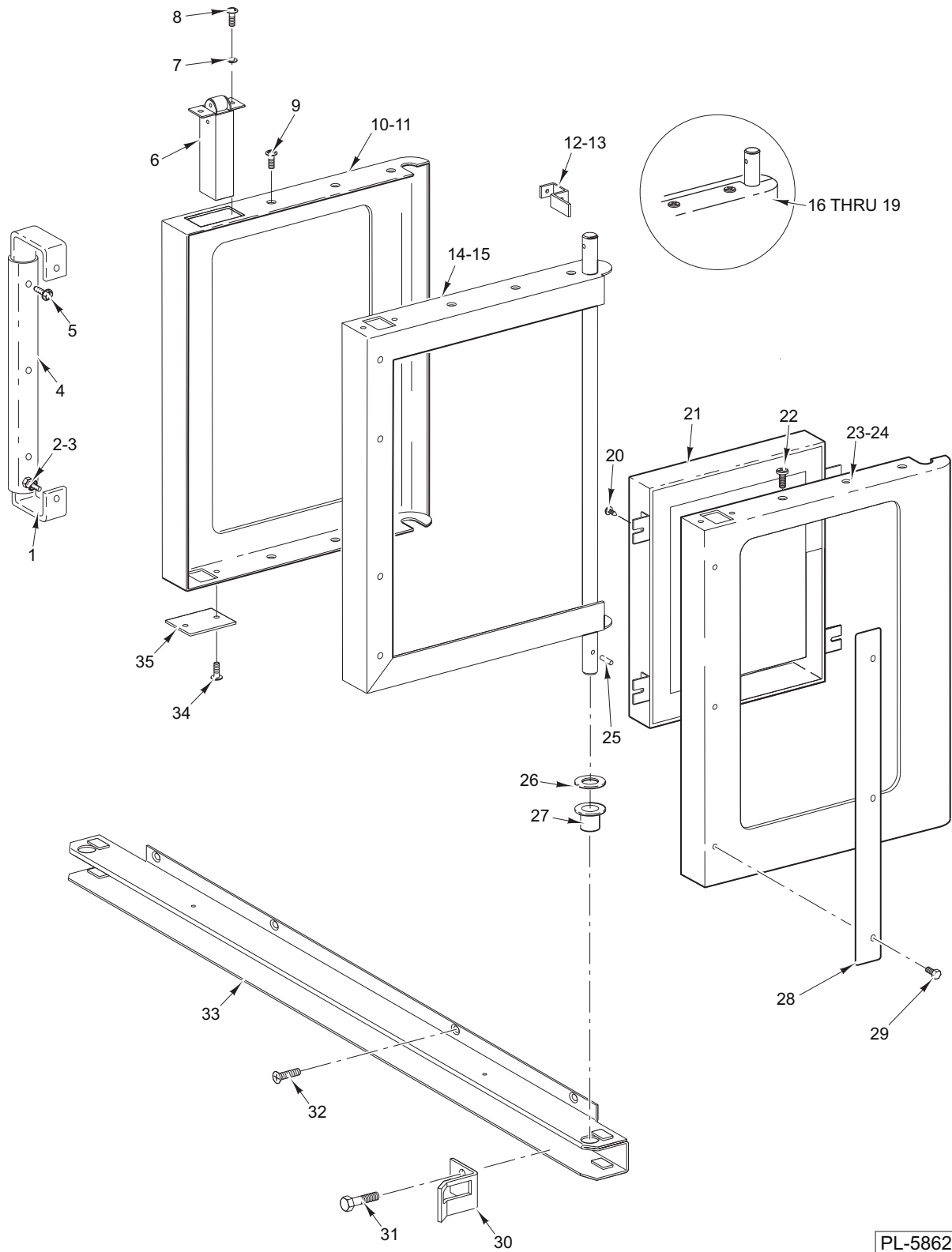

PL-58627

**DOOR ASSEMBLY
(INDEPENDENTLY OPENING DOORS) (CURRENT CONSTRUCTION)**

**DOOR ASSEMBLY
(INDEPENDENTLY OPENING DOORS) (CURRENT CONSTRUCTION)**

ILLUS. PL-58627	PART NO.	NAME OF PART	AMT.
1	00-357929-00001	Handle Assy. – Door	1
2	SC-041-01	Cap Screw 1/4-20 x 3/4 Hex Hd. (SST).....	2
3	WL-019-37	Lockwasher 1/4 Internal	2
4	00-421923-00001	Grip – Set.....	1
5	SC-113-98	Mach. Screw 10-24 x 1/2 Hex Washer Hd.	3
6	00-497586-00001	Latch – Door Roller.....	1
7	WL-019-35	Lockwasher #10 Internal.....	2
8	SC-117-73	Mach. Screw 10-32 x 5/8 Phil. Truss Hd. (SST).....	2
9	SD-034-22	Self-Tapping Screw 10-16 X 5/8 Phil. Truss Hd., Type AB	2
10	00-358600-00001	Panel – Outer Door (RH) (W/Window).....	1
11	00-358600-00002	Panel – Outer Door (RH) (W/O Window).....	1
12	00-424163-00001	Lever – Door Switch	1
13	SD-034-52	Self-Tapping Screw 8-32 x 1 Hex Washer Hd., Type T.....	1
14	00-421905-000G1	Frame Assy. – Door (RH).....	1
15	00-421904-000G2	Frame Assy. – Door (LH)	1
16	00-499285-000G1	Door Assy. (LH) (W/Window)	1
17	00-499285-000G2	Door Assy. (LH) (W/O Window)	1
18	00-499286-000G1	Door Assy. (RH) (W/Window).....	1
19	00-499286-000G2	Door Assy. (RH) (W/O Window).....	1
20	SD-034-62	Self-Tapping Screw 10-32 x 1/2 Hex Washer Hd., Type T	4
21	00-358534-00001	Window Assy.....	1
22	SD-034-22	Self-Tapping Screw 10-16 X 5/8 Phil. Truss Hd., Type AB	8
23	00-358532-00001	Panel – Inner Door (W/Window).....	1
24	00-358533-00003	Panel – Inner Door (W/O Window)	1
25	PS-004-11	Spirol Pin 3/16 x 1 1/4 Heavy.....	1
26	00-343143-00002	Washer.....	2
27	00-347080-00002	Bearing – Door Shaft	1
28	00-357837-00001	Seal – Door End	1
29	SC-113-78	Cap Screw 1/4-20 x 3/4 Hex Hd.....	3
30	00-499263-00001	Door Stop.....	1
31	SC-113-90	Mach. Screw 1/4-20 x 3/4 Hex Hd.	2
32	SC-022-40	Mach. Screw 1/4-20 x 3/4 Phil. Flat Hd.....	4
33	00-499300-000G1	Channel – Bottom Door Sill	1
34	SD-034-22	Self-Tapping Screw 10-16 X 5/8 Phil. Truss Hd., Type AB	2
35	00-499264-00001	Plate – Latch Cutout	1

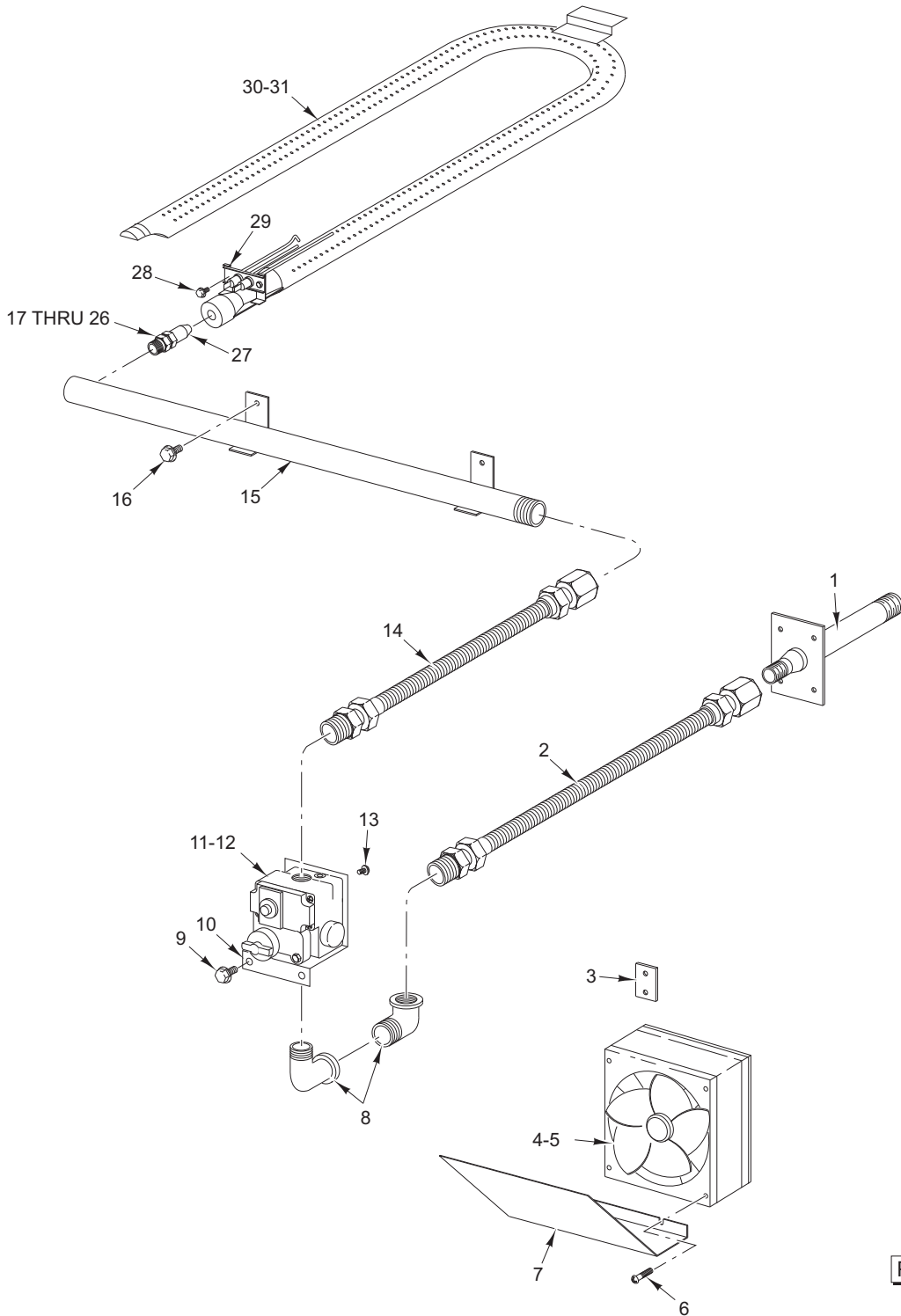

PL-55189

**GAS PIPING AND FLAME CHAMBER
(PREVIOUS CONSTRUCTION - ROBERT SHAW USED BEFORE 3/15/05)**

**GAS PIPING AND FLAME CHAMBER
(PREVIOUS CONSTRUCTION - ROBERT SHAW USED BEFORE 3/15/05)**

ILLUS. PL-55189	PART NO.	NAME OF PART	AMT.
1	00-423819-00003	Pipe – Weldment Gas Inlet.....	1
2	00-423828-00001	Tube – Flex (30 In.).....	1
3	00-425433-00001	Fan – Clip	1
4	00-424940-00001	Fan – Cooling (120 V.).....	1
5	00-424940-00002	Fan – Cooling (230 V.).....	1
6	SD-034-52	Self-Tapping Screw 8-32 x 1 Hex Washer Hd., Type T.....	2
7	00-423820-00001	Deflector – Air (ML-126614, ML-126615, & ML-126616).....	1
8	FP-013-17	Elbow – Street 1/2 x 90 Deg.....	2
9	SC-113-80	Cap Screw 1/4-20 x 1/2 Hex Hd.....	2
10	00-424728-00001	Bracket – Gas Valve	1
11	00-410841-00018	Valve – Gas Control (NAT).....	1
12	00-410841-00019	Valve – Gas Control (PRO/BUT).....	1
13	SC-117-60	Mach. Screw 10-32 x 1 1/4 Oval Hd.....	2
14	00-423828-00002	Tube – Flex (18 In.).....	1
15	00-424138-00001	Manifold	1
16	SC-113-80	Cap Screw 1/4-20 x 1/2 Hex Hd.....	2
17	00-010901-00030	Orifice – Spud (30 Drill) (NAT) (2000 to 2499 Ft.).....	1
18	00-010901-00032	Orifice – Spud (32 Drill) (NAT) (Sea Level to 2000 Ft.).....	1
19	00-010901-00034	Orifice – Spud (34 Drill) (NAT) (3500 to 4499 Ft.).....	1
20	00-010901-00035	Orifice – Spud (35 Drill) (NAT) (2000 to 4000 Ft.).....	1
21	00-010901-00036	Orifice – Spud (36 Drill) (NAT) (4000 to 8000 Ft.).....	1
22	00-010901-00037	Orifice – Spud (37 Drill) (NAT) (8500 to 10500 Ft.).....	1
23	00-010901-00048	Orifice – Spud (48 Drill) (PRO/BUT) (Sea Level to 2499 Ft)	1
24	00-010901-00049	Orifice – Spud (49 Drill) (PRO/BUT) (2500 to 4499 Ft.)	1
25	00-010901-00050	Orifice – Spud (50 Drill) (PRO/BUT) (4500 to 7499 Ft.)	1
26	00-010901-00051	Orifice – Spud (51 Drill) (Sea Level to 2000 Ft.).....	1
27	00-417879-00001	Nozzle – Pilot Burner.....	1
28	SD-034-49	Self-Tapping Screw 8-32 x 1/2 Hex Washer Hd., Type T	2
29	00-424194-00001	Ignitor – Flame Detector	1
30	00-424135-000G1	Burner Assy. (ML-126614, ML-126615, & ML-126616)	1
31	00-424195-000G1	Burner Assy. (ML-126618 & ML-126619).....	1

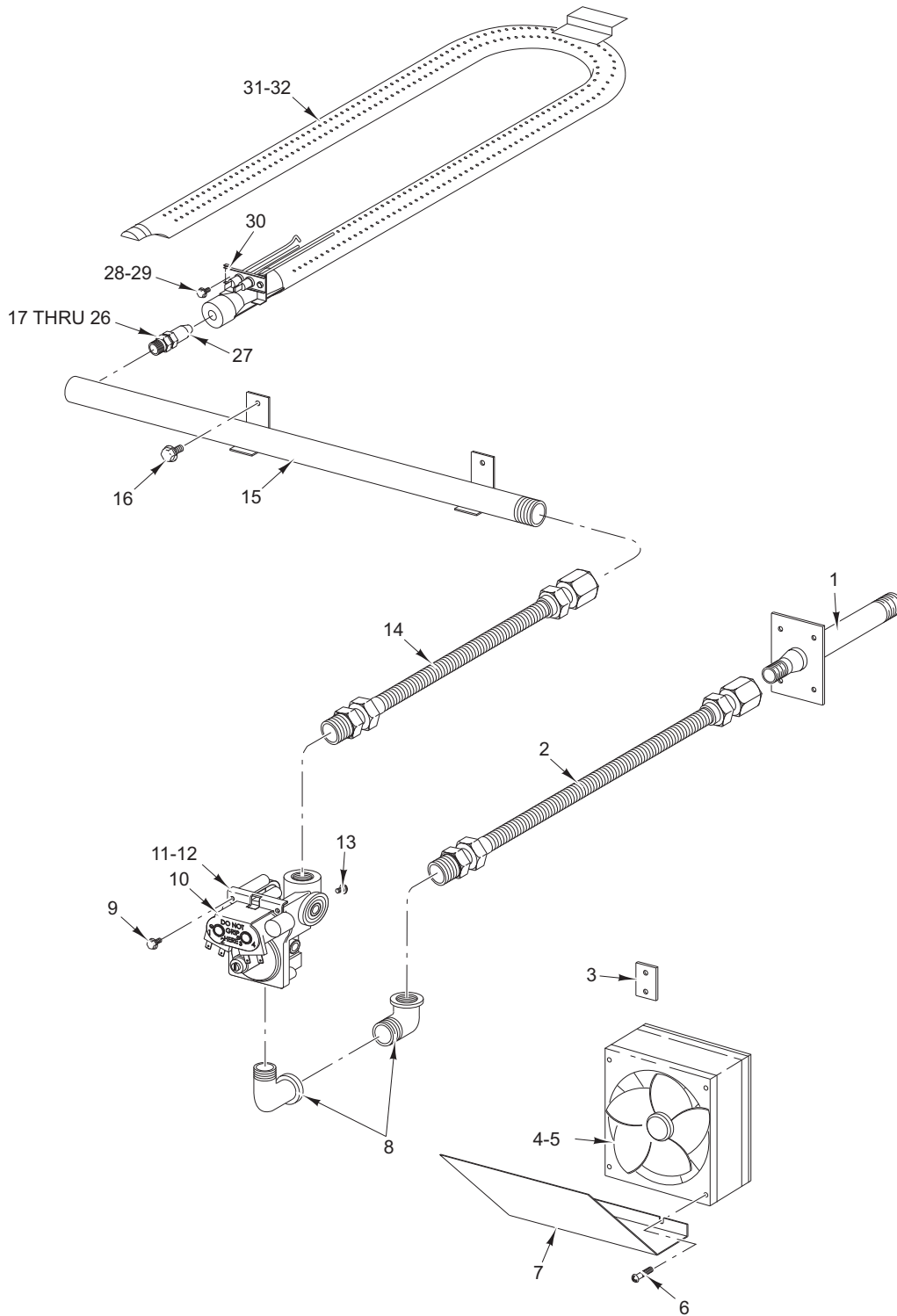

PL-57940

**GAS PIPING AND FLAME CHAMBER
(CURRENT CONSTRUCTION - WHITE ROGERS USED ON OR AFTER 3/15/05)**

**GAS PIPING AND FLAME CHAMBER
(CURRENT CONSTRUCTION - WHITE ROGERS USED ON OR AFTER 3/15/05)**

ILLUS. PL-57940	PART NO.	NAME OF PART	AMT.
1	00-423819-00003	Pipe – Weldment Gas Inlet.....	1
2	00-423828-00006	Tube – Flex (30 In.).....	1
3	00-425433-00001	Fan – Clip	1
4	00-424940-00001	Fan – Cooling (120 V.).....	1
5	00-424940-00002	Fan – Cooling (230 V.).....	1
6	SD-034-52	Self-Tapping Screw 8-32 x 1 Hex Washer Hd., Type T.....	2
7	00-423820-00001	Deflector – Air (ML-126614, ML-126615, & ML-126616).....	1
8	FP-078-75	Elbow – Pipe 3/8 x 90 Deg.	2
9	SC-113-80	Cap Screw 1/4-20 x 1/2 Hex Hd.....	2
10	00-424728-00002	Bracket – Gas Valve	1
11	00-497269-00001	Valve – Gas Control (NAT).....	1
12	00-497269-00002	Valve – Gas Control (PRO/BUT).....	1
13	SC-117-60	Mach. Screw 10-32 x 1 1/4 Oval Hd.	2
14	00-423828-00007	Tube – Flex (18 In.).....	1
15	00-424138-00001	Manifold	1
16	SC-113-80	Cap Screw 1/4-20 x 1/2 Hex Hd.....	2
17	00-010901-00030	Orifice – Spud (30 Drill) (NAT) (2000 to 2499 Ft.).....	1
18	00-010901-00032	Orifice – Spud (32 Drill) (NAT) (Sea Level to 2000 Ft.).....	1
19	00-010901-00034	Orifice – Spud (34 Drill) (NAT) (3500 to 4499 Ft.).....	1
20	00-010901-00035	Orifice – Spud (35 Drill) (NAT) (2000 to 4000 Ft.).....	1
21	00-010901-00036	Orifice – Spud (36 Drill) (NAT) (4000 to 8000 Ft.).....	1
22	00-010901-00037	Orifice – Spud (37 Drill) (NAT) (8500 to 10500 Ft.).....	1
23	00-010901-00048	Orifice – Spud (48 Drill) (PRO/BUT) (Sea Level to 2499 Ft.)	1
24	00-010901-00049	Orifice – Spud (49 Drill) (PRO/BUT) (2500 to 4499 Ft.)	1
25	00-010901-00050	Orifice – Spud (50 Drill) (PRO/BUT) (4500 to 7499 Ft.)	1
26	00-010901-00051	Orifice – Spud (51 Drill) (Sea Level to 2000 Ft.).....	1
27	00-417879-00001	Nozzle – Pilot Burner	1
28	SD-114-24	Mach. Screw 8-32 x 1/2 Phil. Pan Hd.....	2
29	NS-044-07	Nut Assy. 8-32 Hex	2
30	00-424194-00001	Ignitor – Flame Detector	1
31	00-424135-000G1	Burner Assy. (ML-126614, ML-126615, & ML-126616)	1
32	00-424195-000G1	Burner Assy. (ML-126618 & ML-126619).....	1

