



CATALOG OF REPLACEMENT PARTS

HALF SIZE GAS CONVECTION OVENS

ML-114573
ML-114575

HGC20
HGC20D

Table of Contents

5	CONTROL PANEL (HGC20) (PREVIOUS CONSTRUCTION) (PRIOR TO FEBRUARY 2003)
7	CONTROL PANEL (HGC20) (CURRENT CONSTRUCTION)
9	COMPUTERIZED CONTROLS (HGC20D) (PREVIOUS CONSTRUCTION)
11	COMPUTERIZED CONTROLS (HGC20D) (CURRENT CONSTRUCTION)
13	COMPONENT PANEL
15	DOOR ASSEMBLY
17	CABINET
19	GAS BURNER AND BLOWER

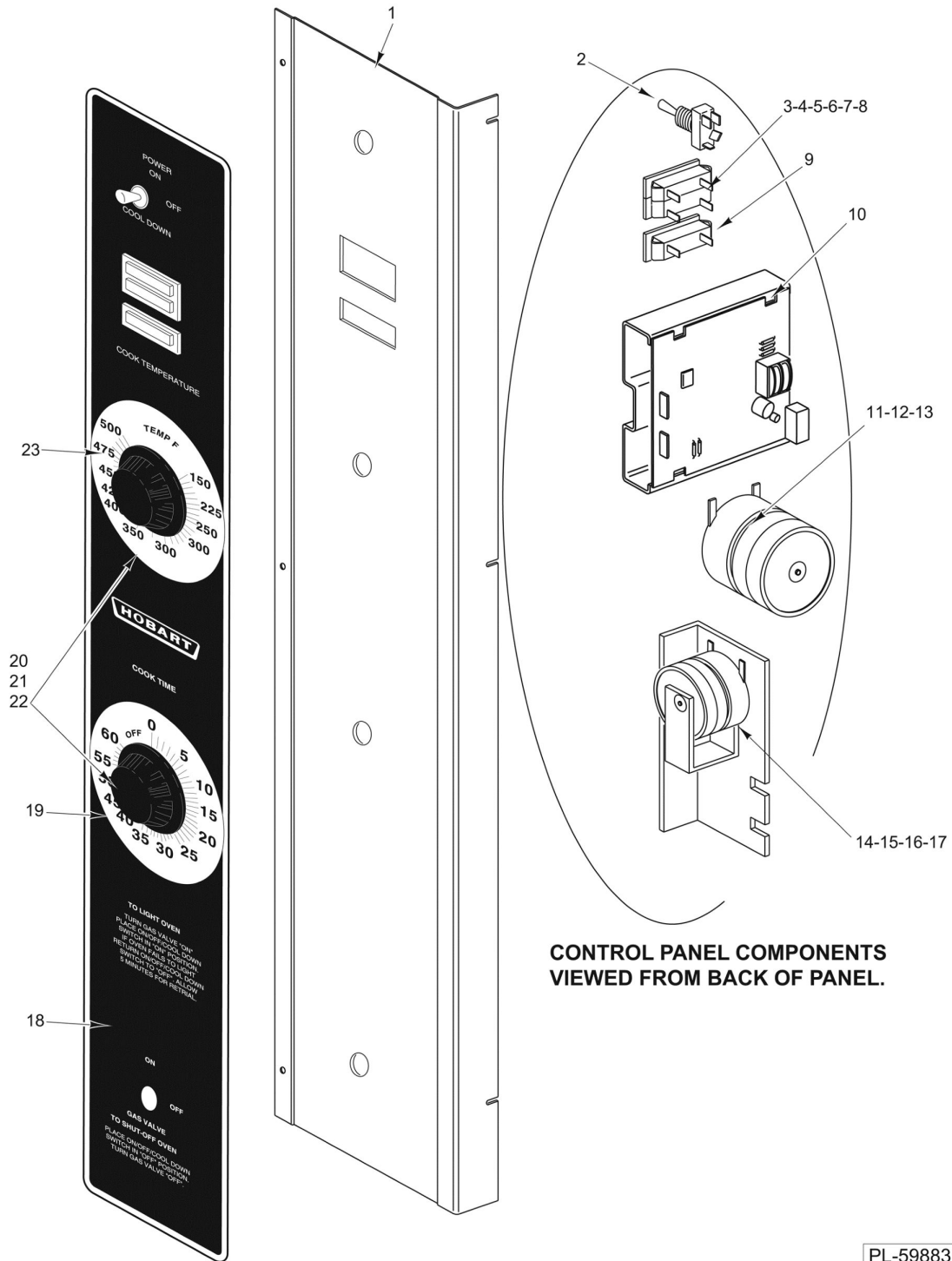

**CONTROL PANEL COMPONENTS
VIEWED FROM BACK OF PANEL.**

PL-59883

**CONTROL PANEL
(HGC20)
(PREVIOUS CONSTRUCTION)
(PRIOR TO FEBRUARY 2003)**

**CONTROL PANEL
(HGC20)
(PREVIOUS CONSTRUCTION)
(PRIOR TO FEBRUARY 2003)**

ILLUS. PL-59883	PART NO.	NAME OF PART	AMT.
1	00-422561-000G1	Panel - Control.....	1
2	00-340324-00008	Switch (On/Off/Cooldown) (4 P.D.T.).....	1
3	00-354575-00007	Light - Indicator (Amber) (200-240 V.).....	1
4	00-354575-00009	Light - Indicator (Clear) (200-240 V.).....	1
5	00-913102-00161	Light - Indicator (Double) (200-240 V.) (Incls. Items 3 & 4).....	1
6	00-354575-00008	Light - Indicator (Amber) (110-120 V.).....	1
7	00-354575-00010	Light - Indicator (Clear) (110-120 V.).....	1
8	00-913102-00163	Light - Indicator (Double) (110-120 V.) (Incls. Items 6 & 7).....	1
9	00-354575-00004	Light - Indicator (No Ignition).....	1
10	00-353613-00002	Controller - Temperature (500 Deg.).....	1
11	00-411690-00001	Timer (120 V.) (60 Hz.) (1-Hr.).....	1
12	00-411690-00002	Timer (200-240 V.) (60 Hz.) (1-Hr.).....	1
13	00-411690-00005	Timer (240 V.) (50 Hz.) (1-Hr.).....	1
14	00-411499-00003	Buzzer (230 V.).....	1
15	00-411499-00004	Buzzer (115 V.).....	1
16	SD-034-49	Self-Tapping Screw 8-32 x 1/2 Hex Washer Hd., Type T.....	1
17	WL-014-10	Lockwasher 1/4 External Shakeproof.....	1
18	00-422912-00001	Overlay - Control Panel.....	1
19	00-358538-00001	Plate - Dial Timer.....	1
20	00-411242-00001	Knob.....	2
21	SC-114-83	Mach. Screw 6-32 x 1/4 Slotted Pan Hd. (SST).....	2
22	WS-028-20	Washer (SST).....	2
23	00-358539-00001	Plate - Temperature Dial (Fahrenheit).....	1

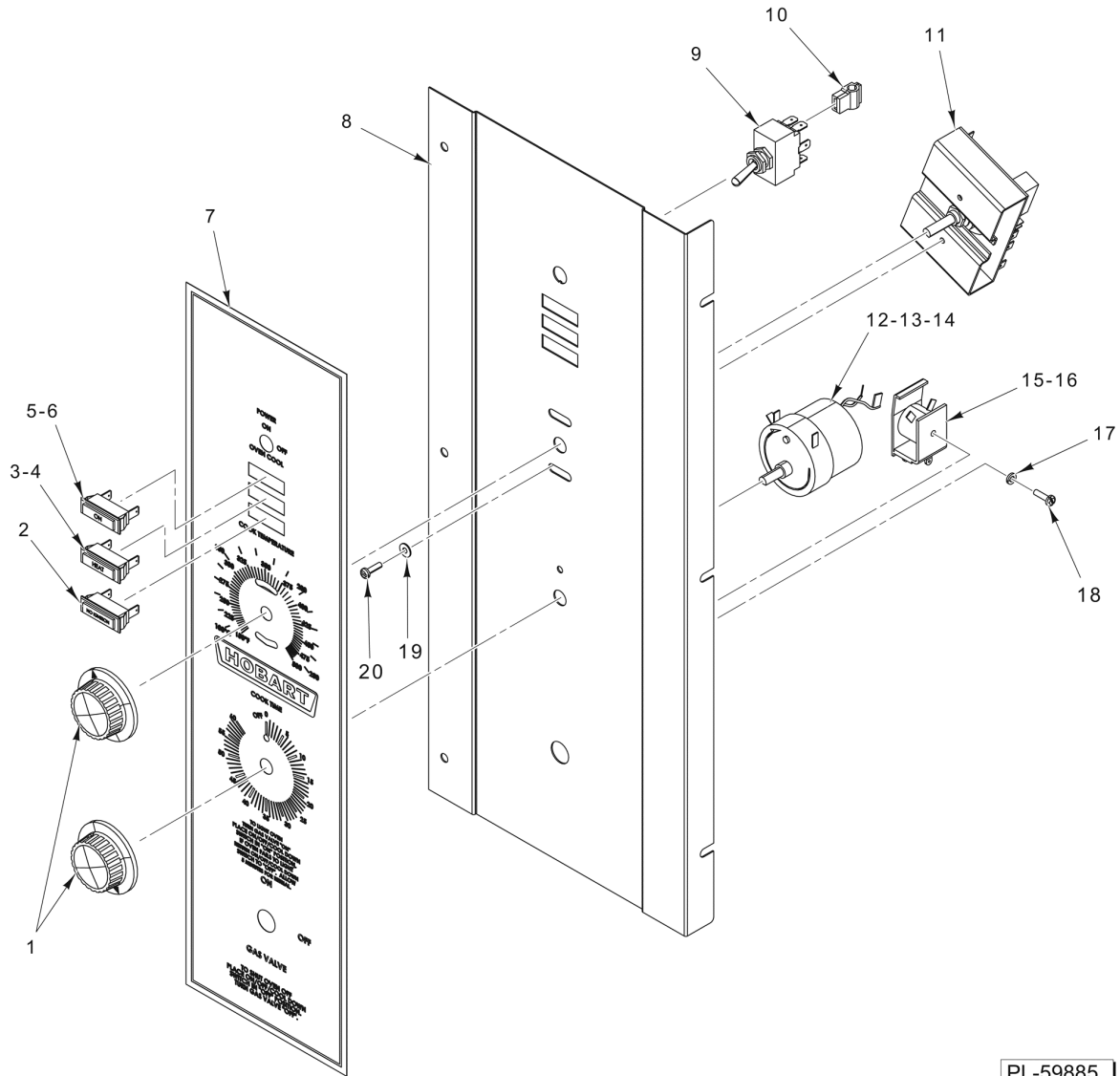

PL-59885

**CONTROL PANEL
(HGC20)
(CURRENT CONSTRUCTION)**

**CONTROL PANEL
(HGC20)
(CURRENT CONSTRUCTION)**

ILLUS. PL-59885	PART NO.	NAME OF PART	AMT.
1	00-411242-00001	Knob.....	2
2	00-354575-00004	Light - Indicator.....	1
3	00-354575-00009	Light - Indicator (Clear) (240 V.).....	1
4	00-354575-00010	Light - Indicator (Clear) (120 V.).....	1
5	00-354575-00007	Light - Indicator (Amber) (240 V.).....	1
6	00-354575-00008	Light - Indicator (Amber) (120 V.).....	1
7	00-428124-00001	Overlay - Control Panel.....	1
8	00-428129-000G1	Panel - Control Weldment.....	1
9	00-340324-00008	Switch (On/Off/Cooldown) (4 P.D.T.).....	1
10	00-412575-00007	Insulator - Terminal.....	1
11	00-353613-00002	Controller - Temperature (500 Deg.).....	1
12	00-411690-00001	Timer (120 V.) (60 Hz.) (1-Hr.).....	1
13	00-411690-00002	Timer (200-240 V.) (60 Hz.) (1-Hr.).....	1
14	00-411690-00005	Timer (240 V.) (50 Hz.) (1-Hr.).....	1
15	00-411499-00003	Buzzer (230 V.).....	1
16	00-411499-00004	Buzzer (115 V.).....	1
17	WL-003-12	Lockwasher #8 Helical.....	1
18	SC-114-83	Mach. Screw 6-32 x 1/4 Slotted Pan Hd. (SST).....	1
19	WS-024-20	Washer.....	2
20	SC-114-83	Mach. Screw 6-32 x 1/4 Slotted Pan Hd. (SST).....	2

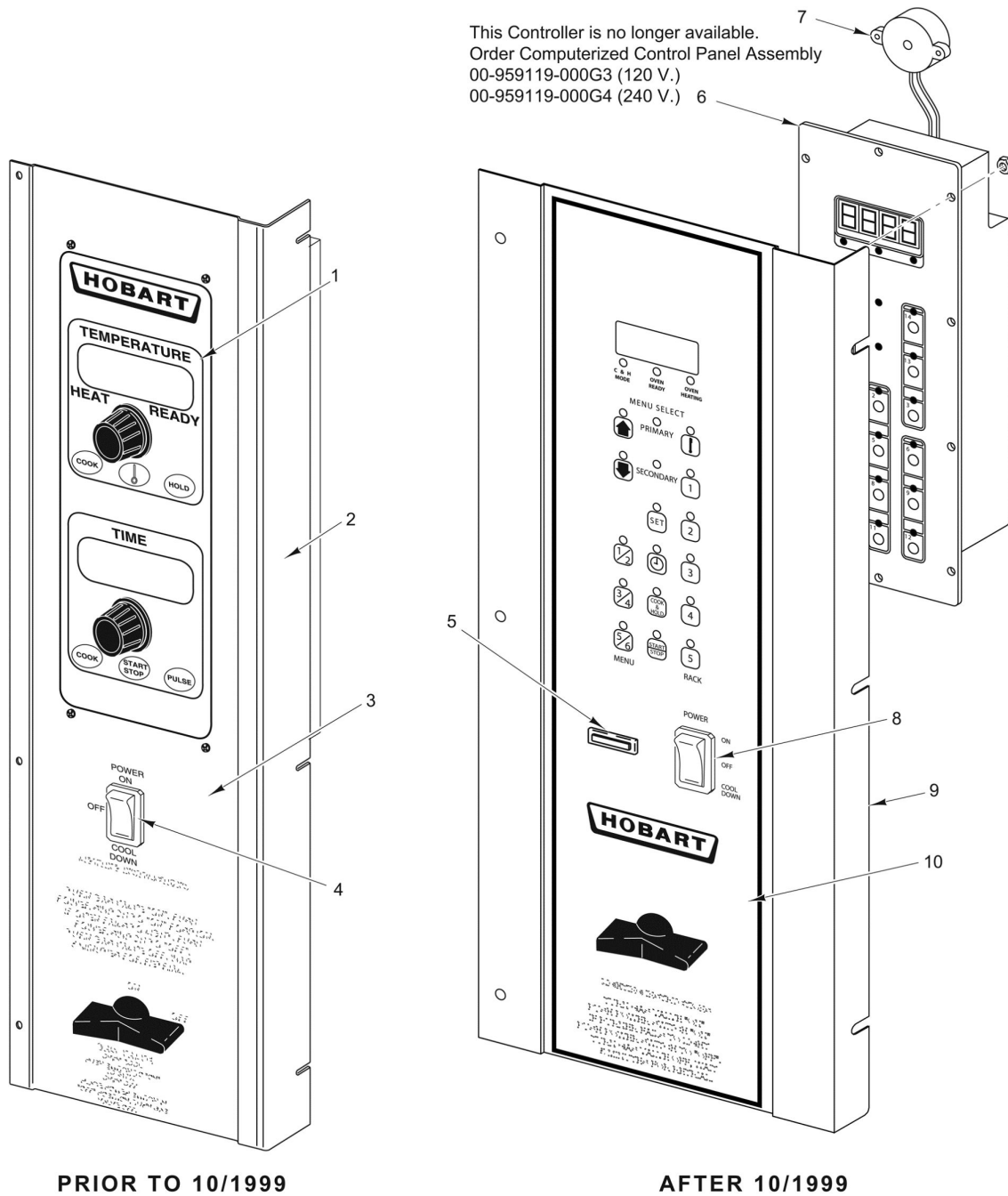

PL-59887

**COMPUTERIZED CONTROLS
 (HGC20D)
 (PREVIOUS CONSTRUCTION)**

**COMPUTERIZED CONTROLS
(HGC20D)
(PREVIOUS CONSTRUCTION)**

ILLUS.	PART NO.	NAME OF PART	AMT.
PL-59887			
1	00-355903-00005	Controller (With Cook, Hold , & Pulse).....	1
2	00-422921-000G1	Panel - Control Weldment.....	1
3	00-422666-00001	Overlay.....	1
4	00-358628-00001	Switch - Rocker (3 Position).....	1
5	00-354575-00004	Light - Indicator.....	1
*6		Controller.....	1
7	00-423918-00001	Electronic Beeper.....	1
8	00-358628-00001	Switch - Rocker (3 Position).....	1
9	00-426687-000G1	Panel - Control Weldment.....	1
10	00-426696-00001	Overlay.....	1
	00-959119-000G3	Panel - Control Assy. (Complete) (120 V.).....	AR
	00-959119-000G4	Panel - Control Assy. (Complete) (240 V.).....	AR

* (No Longer Available, Order 00-959119-000G3 or 00-959119-000G4)

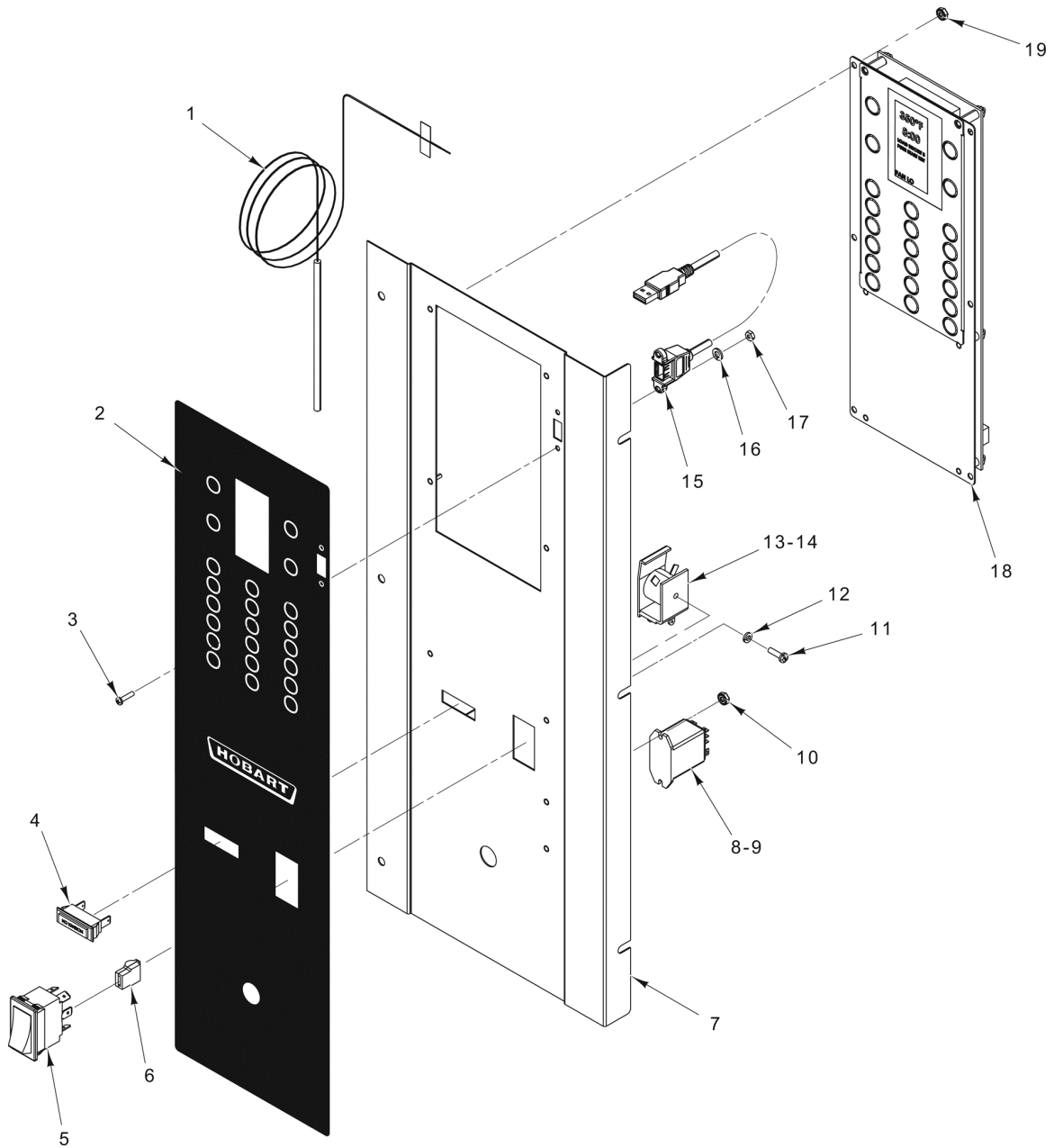

PL-59889

**COMPUTERIZED CONTROLS
(HGC20D)
(CURRENT CONSTRUCTION)**

**COMPUTERIZED CONTROLS
(HGC20D)
(CURRENT CONSTRUCTION)**

ILLUS.	PART NO.	NAME OF PART	AMT.
PL-59889			
1	00-920883-00003	Probe - Temperature.....	1
2	00-959126-00003	Overlay (Hobart).....	1
3		Mach. Screw 4-40 x 1/2 Phil. Pan Hd.....	2
4	00-354575-00004	Light - Indicator.....	1
5	00-358628-00001	Switch - Rocker (3 Position).....	1
6	00-412575-00007	Insulator - Terminal.....	2
7	00-959116-000G1	Panel - Control Weldment.....	1
8	00-416535-00006	Relay - Heating (120 V.).....	1
9	00-416535-00007	Relay - Heating (200-240 V.).....	1
10	NS-046-89	Nut Assy. 6-32 Hex.....	2
11	SC-114-83	Mach. Screw 6-32 x 1/4 Slotted Pan Hd. (SST).....	1
12	WL-003-12	Lockwasher #8 Helical.....	1
13	00-411499-00003	Buzzer (230 V.).....	1
14	00-411499-00004	Buzzer (115 V.).....	1
15	00-959000-000G1	Cable Assy. (USB) (1 Ft.) (Incls. Items 3, 16, & 17).....	1
16		Lockwasher.....	2
17		Nut 4-40 Hex.....	2
18	00-959077-00001	Controller - Cooking (NCC).....	1
19	NS-046-89	Nut Assy. 6-32 Hex.....	6

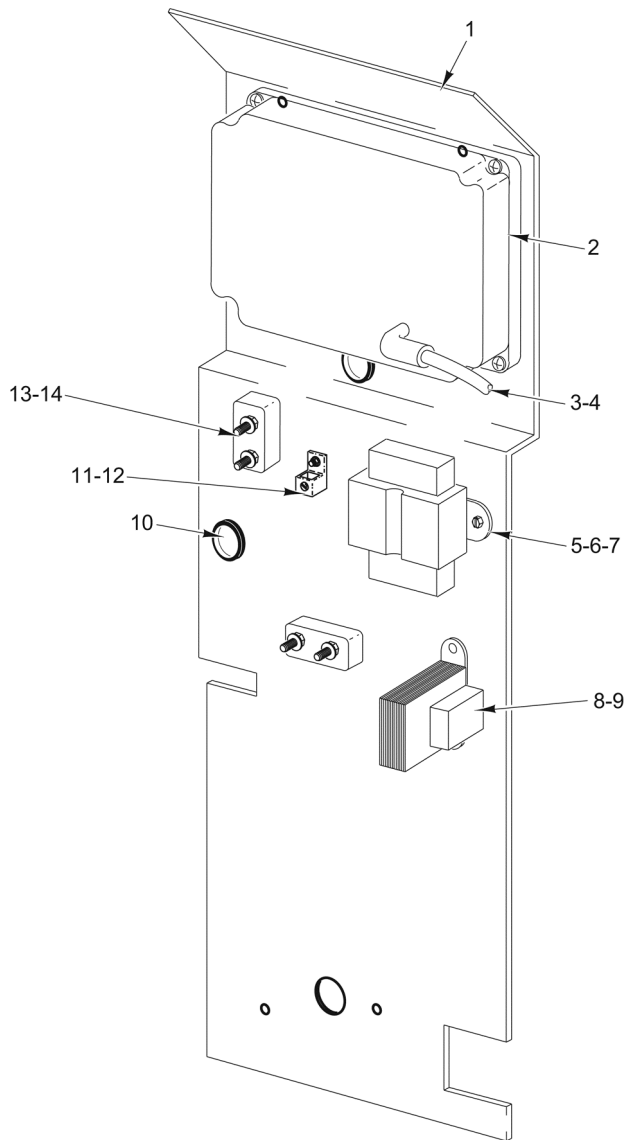

PL-59891

COMPONENT PANEL

COMPONENT PANEL

ILLUS.	PART NO.	NAME OF PART	AMT.
PL-59891			
1	00-422712-00001	Panel - Component.....	1
2	00-354447-00001	Controller - Spark Ignitor.....	1
3	00-355087-00001	Cable - High Voltage.....	1
4	00-354472-00002	Harness Assy.....	1
5	00-411500-00013	Transformer (200-240 VAC, 28 V., 20 VA).....	1
6	00-421758-000G1	Transformer (120 V.) (24 V. Output).....	1
7	SD-034-49	Self-Tapping Screw 8-32 x 1/2 Hex Washer Hd., Type T.....	2
8	00-358629-00001	Transformer (6/12/120VAC) (HGC20D) (Used on Machines Built Prior to November 1999).....	1
9	SD-034-49	Self-Tapping Screw 8-32 x 1/2 Hex Washer Hd., Type T.....	2
10	FE-016-32	Bushing - Snap (Electrical).....	2
11	00-417856-00001	Lug - Grounding (With Set Screw).....	1
12	SD-034-49	Self-Tapping Screw 8-32 x 1/2 Hex Washer Hd., Type T.....	1
13	00-417934-000G1	Block Assy. - Porcelain.....	2
14	SD-034-49	Self-Tapping Screw 8-32 x 1/2 Hex Washer Hd., Type T.....	2
	00-405016-00001	Cord - Electric Supply (120 V. Only).....	1

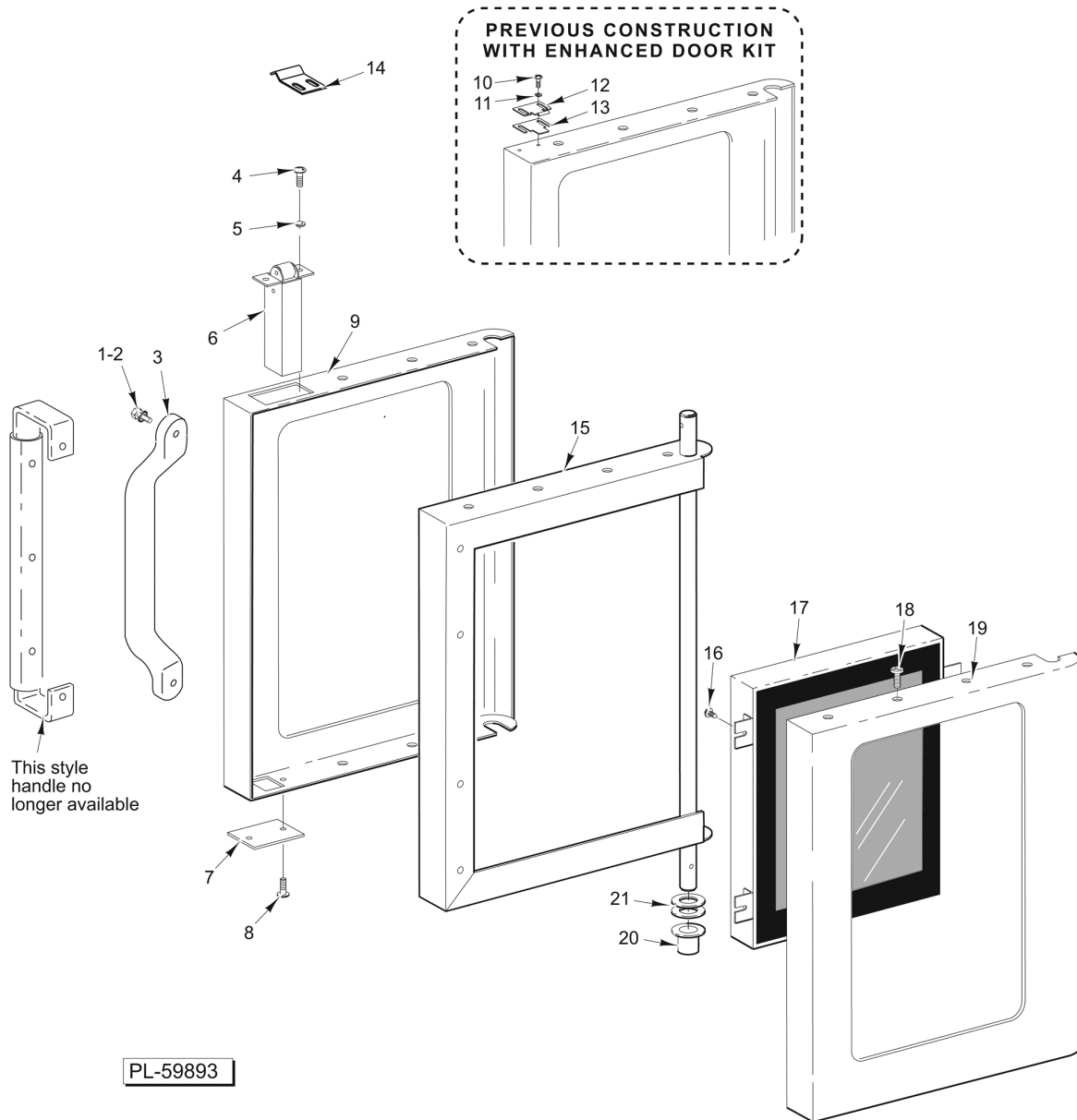

DOOR ASSEMBLY

DOOR ASSEMBLY

ILLUS.	PART NO.	NAME OF PART	AMT.
PL-59893			
1	00-959087-00001	Screw 1/4-20 x 1-1/4 Black Hd.....	2
2	WL-013-14	Lockwasher 1/4 Internal Shakeproof.....	2
3	00-957108-00001	Handle - Molded (Black).....	1
4	SC-117-73	Mach. Screw 10-32 x 5/8 Phil. Truss Hd.....	2
5	WL-019-35	Lockwasher #10 Internal.....	2
6	00-497586-00001	Latch - Door Roller (Mounted to Door).....	1
7	00-499264-00001	Plate - Latch Cutout.....	1
8	SD-034-22	Self-Tapping Screw 10-16 X 5/8 Phil. Truss Hd., Type AB.....	2
9	00-360887-00001	Panel - Outer Door (With Window).....	1
10	SC-115-51	Mach. Screw 10-32 x 1/2 Phil. Truss Hd.....	2
11	WL-019-35	Lockwasher #10 Internal.....	2
12	00-423847-00001	Strike - Door (Mounted to Door).....	2
13	00-423848-00001	Shim - Door Strike.....	1
14	00-499270-00001	Strike - Door (Attaches to Upper "C" Channel).....	1
15	00-359703-000G1	Door Frame Assy.....	1
16	SD-034-62	Self-Tapping Screw 10-32 x 1/2 Hex Washer Hd., Type T.....	4
17	00-358534-00001	Window Assy.....	1
18	SD-034-22	Self-Tapping Screw 10-16 X 5/8 Phil. Truss Hd., Type AB.....	7
19	00-360889-000G1	Panel - Inner Door (With Window).....	1
20	00-347080-00002	Bearing - Door Shaft.....	1
21	00-343143-00002	Washer.....	4
	00-423014-000G2	Door Kit - Enhanced (Prior to 7/15/08) (Incls. Items 4, 5, 7, & 12).....	1
	00-499305-000G1	Door Assy.....	1
	00-913102-00179	Kit - Handle (Incls. Items 1, 2, & 3).....	1

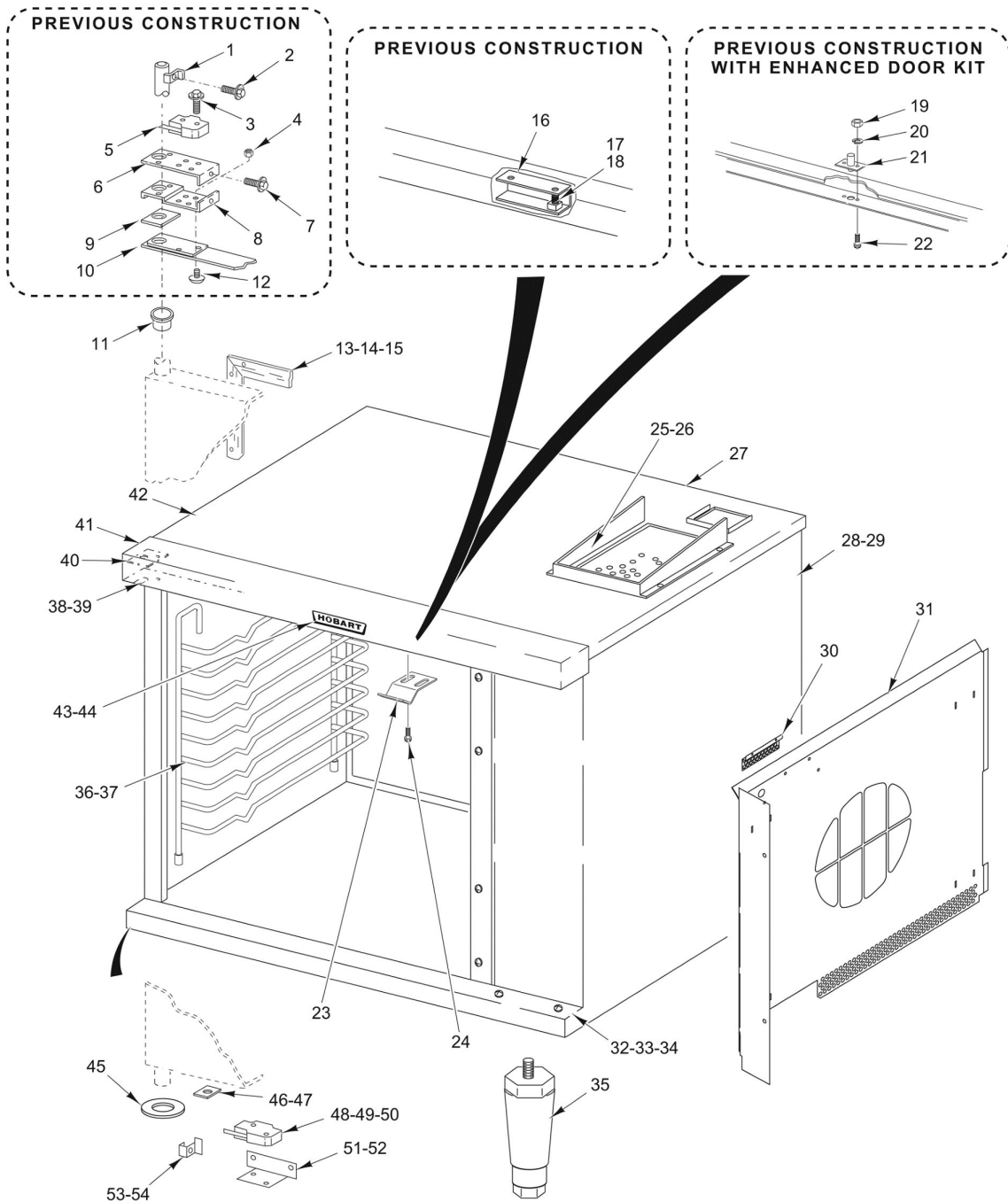

PL-59895

CABINET

CABINET

ILLUS. PL-59895	PART NO.	NAME OF PART	AMT.
1	00-427855-00001	Striker - Door Switch (Used on machines built prior to 12/2008).....	1
2	SD-036-30	Self-Tapping 8-32 x 1/4 Slotted Hex Washer Hd., Type T.....	1
3	SD-034-47	Self-Tapping Screw 6-32 x 1 Hex Washer Hd., Type T.....	2
4	NS-046-52	Nut Assy. 1/4-20 Hex.....	2
5	00-353782-00001	Switch - Door (Machines built prior to 8/2001).....	1
6	00-353780-00001	Bracket - Switch (Machines built prior to 8/2001).....	1
7	SD-036-30	Self-Tapping 8-32 x 1/4 Slotted Hex Washer Hd., Type T.....	1
8	00-353778-00001	Support - Switch.....	1
9	00-353482-00001	Spacer.....	1
10	00-353483-00001	Plate - Upper Door Bearing.....	1
11	00-347080-00002	Bearing - Door Shaft.....	1
12	SC-022-40	Mach. Screw 1/4-20 x 3/4 Phil. Flat Hd. (SST).....	2
13	00-423281-00001	Seal - Door (LH or RH).....	2
14	00-423280-00001	Seal - Door (Top & Bottom).....	2
15	SD-034-05	Self-Tapping Screw 6-20 x 3/8 Phil. Pan Hd., Type AB.....	16
16	00-355344	Channel - Latch (Used on machines built prior to 12/1997).....	1
17	00-417810-00003	Spring - Compression (Used on machines built prior to 12/1997).....	1
18	00-411794-00001	Catch - Door (Used on machines built prior to 12/1997).....	1
19	NS-046-88	Nut Assy. 10-32 Hex.....	2
20	WL-019-35	Lockwasher #10 Internal.....	2
21	00-347545-00001	Catch Assy. - Door (Roller Ball Style).....	1
22	SC-115-51	Mach. Screw 10-32 x 1/2 Phil. Truss Hd.....	2
23	00-499270-00001	Strike - Door.....	1
24	SC-115-51	Mach. Screw 10-32 x 1/2 Phil. Truss Hd.....	2
25	00-354647-00001	Guard.....	1
26	SD-034-22	Self-Tapping Screw 10-16 X 5/8 Phil. Truss Hd., Type AB.....	4
27	00-354476-00002	Back (SST).....	1
28	00-422715-00002	Panel - Side (RH) (SST).....	1
29	00-422724-00002	Panel - Side (LH) (SST).....	1
30	00-499274-00001	Cover - Probe.....	1
31	00-360863-00001	Baffle - Blower Inner.....	1
32	00-422714-00001	Cover - Lower (Used on machines built prior to 12/2008).....	1
33	00-957632-00001	Cover - Lower (Used on machines built after 12/2008).....	1
34	00-422592-00001	Sill - Door.....	1
35	00-348164-00001	Leg - Adjustable Chrome Plated (4 In.).....	4
36	00-347498-00003	Guide - Rack (LH) (Used on machines built prior to 10/26/2012).....	1
	00-959382-00001	Guide - Rack (LH & RH) (Used on machines built after to 10/26/2012).....	2
37	00-347498-00004	Guide - Rack (RH) (Used on machines built prior to 10/26/2012).....	1
38	00-499269-00001	Support - Upper Door (Current Construction).....	1
39	00-422590-00001	Support - Door Upper Reversible (Previous Construction).....	1
40	00-422588-00001	Plate - Cover.....	1
41	00-347593-00001	Cover - Top.....	1
42	00-422595-00002	Top (SST).....	1
43		Nameplate (Hobart).....	1
44	NS-047-79	Pal Nut 3/16.....	2
45	00-343143-00002	Washer.....	1
46	00-353790-00001	Stop.....	1
47	SD-008-27	Self-Tapping Screw 10-16 x 1/2 Phil. Truss Hd., Type B.....	1
48	00-411496-000F1	Switch - Micro.....	1
49	SC-123-87	Mach. Screw 6-32 x 7/8 Slotted Pan Hd.....	1
50	NS-046-89	Nut Assy. 6-32 Hex.....	1
51	00-499338-00001	Bracket - Door Switch (Used on machines built after 12/2008).....	1
52	00-426854-00001	Bracket - Switch Mounting (Used on machines built prior to 12/2008).....	1
53	00-499340-00001	Bracket - Shaft (Micro Switch) (Used on machines built after 12/2008).....	1
54	SD-034-52	Self-Tapping Screw 8-32 x 1 Hex Washer Hd., Type T.....	1
	00-423014-000G2	Door Kit - Enhanced (Prior to 7/15/08) (Incls. Items 19 thru 22).....	1
	00-347497-00002	Rack (Used on machines built prior to 10/26/2012).....	AR
	00-959381-00001	Rack (Used on machines built after to 10/26/2012).....	AR
	00-353948-00002	Caster Assy. (Swivel).....	2
	00-341655-00007	Caster (Rigid) (5" Dia.).....	2

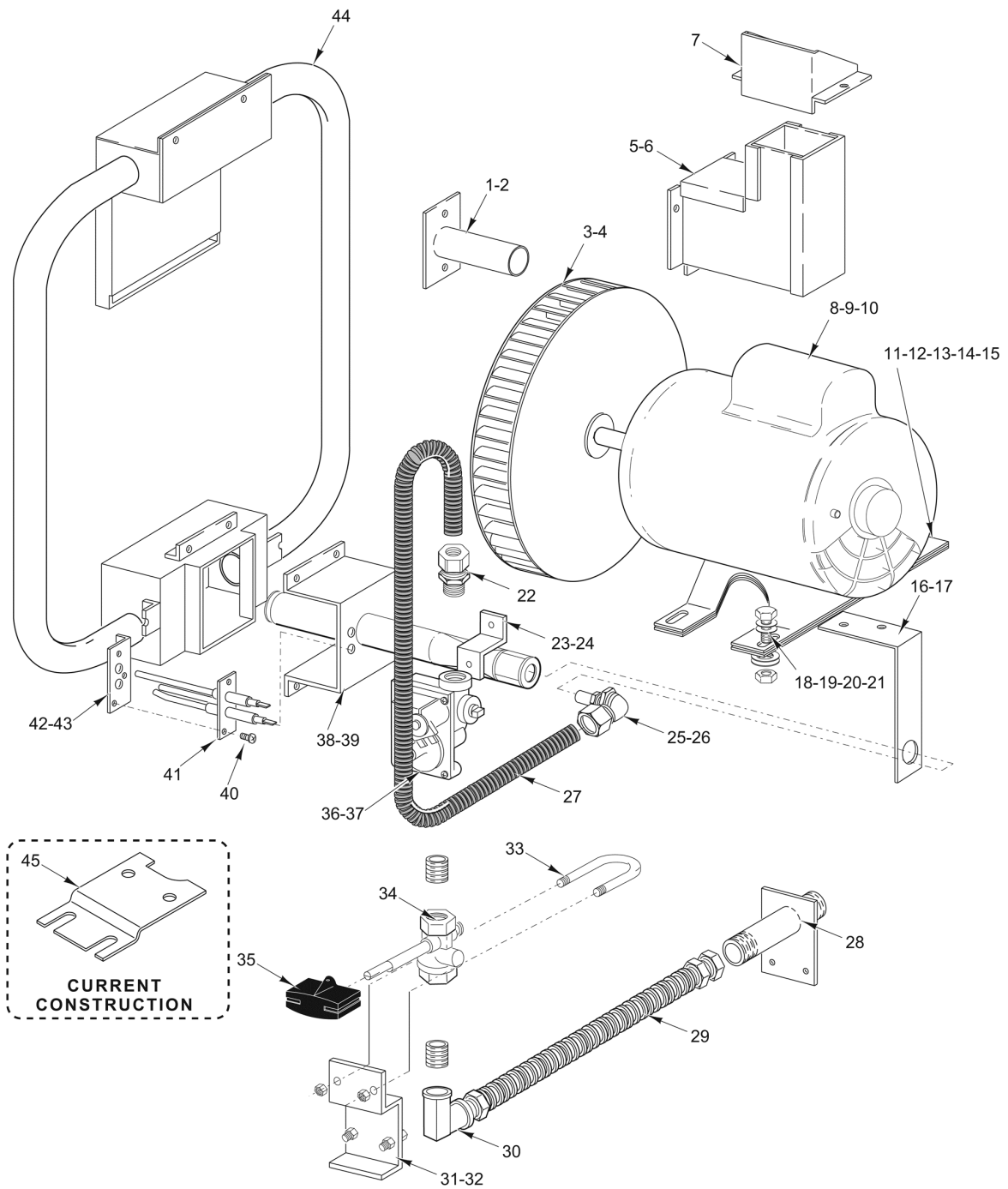

PL-59897

GAS BURNER AND BLOWER

GAS BURNER AND BLOWER

ILLUS.	PART NO.	NAME OF PART	AMT.
PL-59897			
1	00-354431-00001	Flue Assy.....	1
2	SD-034-21	Self-Tapping Screw 10-16 x 1/2 Hex Washer Hd., Type AB.....	2
3	00-354262-00001	Blower.....	1
4	SC-114-03	Mach. Screw 10-32 x 1/2 Hex Washer Hd.....	2
5	00-354446-00001	Deflector Assy.....	1
6	SD-034-21	Self-Tapping Screw 10-16 x 1/2 Hex Washer Hd., Type AB.....	2
7	00-354482-00001	Vent Extension.....	1
8	FE-023-56	Bushing - Electric Snap.....	1
9	00-358516-00001	Motor 1/2 Hp. (2-Speed) (115 V., 50/60 Hz., 1 Ph.).....	1
10	00-358516-00002	Motor 1/2 Hp. (2-Speed) (208-240 V., 50/60 Hz., 1 Ph.).....	1
11	00-347786-00002	Motor Mount Assy.....	1
12	SC-116-84	Cap Screw 5/16-18 x 1-1/8 Hex Hd.....	4
13	WS-029-46	Washer.....	4
14	NS-046-86	Nut Assy. 5/16-18 "KEPS" Hex.....	4
15	00-358723-00001	Spacer - Steel.....	1
16	00-354485-00001	Support - Gas Inlet.....	1
17	SD-034-62	Self-Tapping Screw 10-32 x 1/2 Hex Washer Hd., Type T.....	2
18	SC-116-84	Cap Screw 5/16-18 x 1-1/8 Hex Hd.....	4
19	WS-029-46	Washer.....	4
20	WS-029-46	Washer.....	4
21	NS-046-86	Nut Assy. 5/16-18 "KEPS" Hex.....	4
22	FP-085-68	Fitting-Tube 7/16 (Brass).....	1
23	00-422982-00001	Support - Gas Valve (Previous Construction).....	1
24	SD-034-52	Self-Tapping Screw 8-32 x 1 Hex Washer Hd., Type T.....	2
25	00-348031-00009	Orifice 90 Deg. Compression (#42 Drill).....	1
26	00-348031-00005	Orifice 90 Deg. Compression (#54 Drill).....	1
27	00-426508-00016	Tube - Flex 7/16 O.D. (16 In. Lg.).....	1
28	00-354513-00001	Pipe & Support Assy.....	1
29	00-423828-00004	Tube - Flex (18 In. Lg.).....	1
30	FP-087-19	Elbow - Reducing 1/2 x 3/8 x 90 Deg. (Brass).....	1
31	00-356735-00001	Support - Valve.....	1
32	NS-046-52	Nut Assy. 1/4-20 Hex.....	2
33	00-521820	U-Bolt.....	1
34	00-407789-00001	Valve - Service.....	1
35	00-402957-00003	Handle - Gas (Black).....	1
36	00-354344-00004	Valve - Gas Control (NAT).....	1
37	00-354344-00005	Valve - Gas Control (LP).....	1
38	00-354519-00001	Burner Assy.....	1
39	00-422918-00001	Gasket.....	1
40	SD-034-05	Self-Tapping Screw 6-20 x 3/8 Phil. Pan Hd., Type AB.....	2
41	00-354444-00001	Ignition Electrode Assy.....	1
42	00-354496-00001	Support - Lighter.....	1
43	SD-034-05	Self-Tapping Screw 6-20 x 3/8 Phil. Pan Hd., Type AB.....	2
44	00-422783-000G1	Heat Exchanger Assy.....	1
45	00-356735	Support - Valve.....	1
	00-348072-00009	Orifice - Hood (#42 Drill).....	1
	00-348072-00010	Orifice - Hood (#43 Drill).....	1
	00-348072-00011	Orifice - Hood (#44 Drill).....	1
	00-348072-00015	Orifice - Hood (#54 Drill).....	1
	00-348072-00016	Orifice - Hood (#55 Drill).....	1
	00-348072-00027	Orifice - Hood (#56 Drill).....	1

