

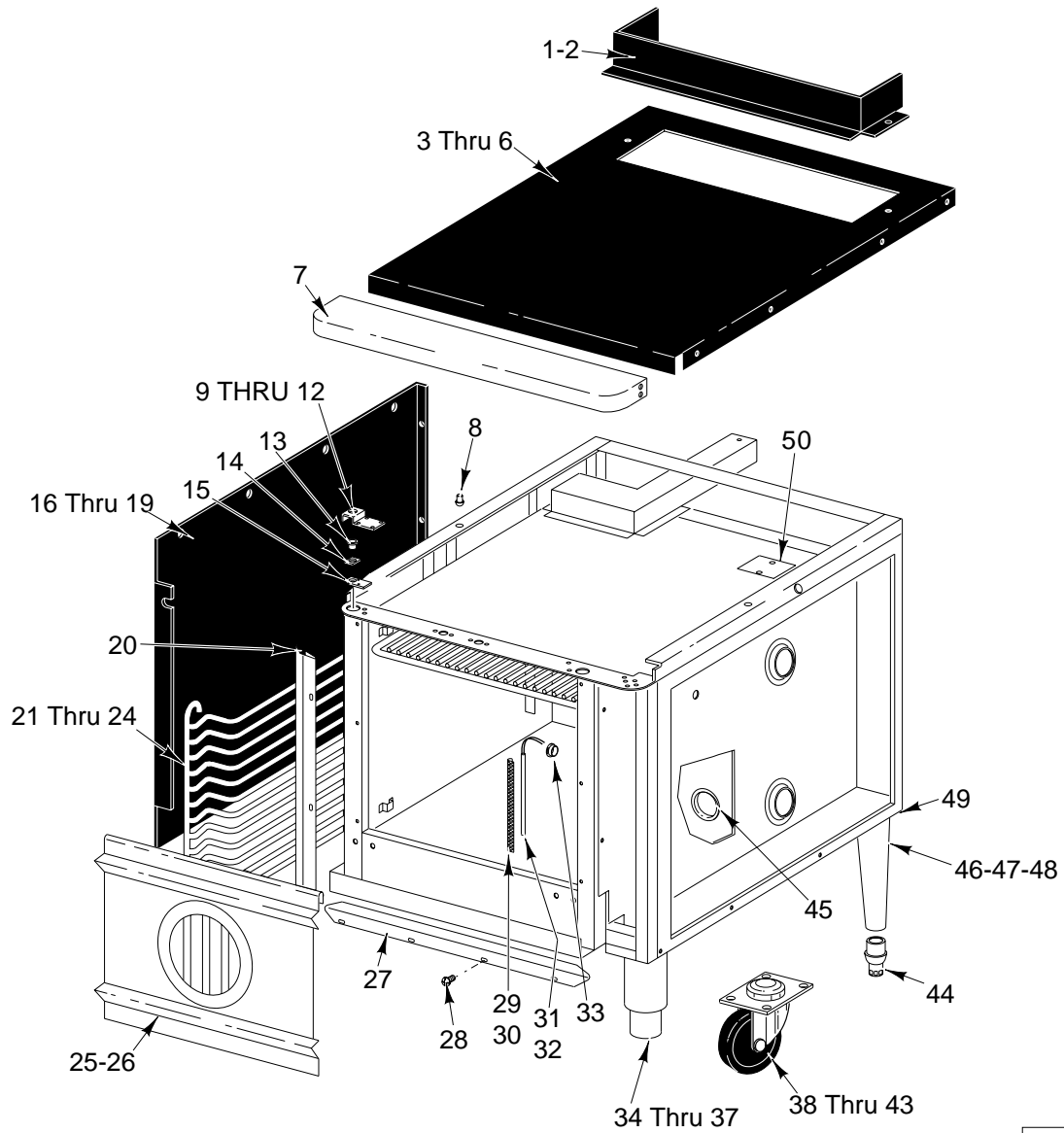

CATALOG OF REPLACEMENT PARTS

GAS CONVECTION OVENS

ML-43856	HGC40
ML-43859	HGC40D
ML-43853	DGC1
ML-114731	HGC60
ML-114732	HGC60D



PL-52607

OVEN (L.H.)

OVEN (L.H.)

ILLUS. PL-52607	PART NO.	NAME OF PART	AMT.
1	00-343516-00001	Shell-Chimney (PTD)(HGC40/HGC60/HGC60D/DGC1)	1
2	00-343516-00002	Shell - Chimney (SST)	1
3	00-343508-00001	Top-Rear (PTD) (HGC40/DGC1)	1
4	00-343508-00002	Top-Rear (SST) (HGC40/HGC40D/DGC1)	1
5	00-343508-00003	Top-Rear (PTD) (HGC60/HGC60D)	1
6	00-343508-00004	Top-Rear (SST) (HGC60/HGC60D)	1
7	00-343501-00001	Top - Front	1
8	00-339337-00001	Stud - Locating	2
9	00-353484-00001	Plate - Retainer	2
10	SC-022-40	Mach. Screw ¼-20 x ¾ Phil. Flat Hd.	4
11	WL-019-22	Lockwasher ¼ Ext.	4
12	NS-046-52	Nut - ¼-20 Hex "Keps"	4
13	00-347080-00002	Bearing - Door Shaft	2
14	00-353482-00001	Spacer	2
15	00-353483-00001	Plate - Upper Door Bearing	2
16	00-357760-00001	Panel-Outer (L.H.) (PTD) (HGC40/DGC1)	1
17	00-357760-00002	Panel-Outer (L.H.) (SST) (HGC40/HGC40D/DGC1)	1
18	00-342262-00007	Panel-Side (L.H.) (HGC60/HGC60D)	1
19	00-342262-00008	Panel-Side (R.H.) (HGC60/HGC60D)	1
20	00-357508-00001	Seal - Door (23 Long)	2
21	00-342141-00001	Rack-Support (L.H.) (HGC40/HGC40D/DGC1)(1.87")	1
22	00-342141-00003	Rack-Support (L.H.) (HGC60/HGC60D)(2.47")	1
23	00-342141-00002	Rack-Support (R.H.) (HGC60/HGC60D)(1.87")	1
24	00-342141-00004	Rack-Support (R.H.) (HGC60/HGC60D)(2.47")	1
25	00-357844-00001	Blower-Baffle (Porcelain) (HGC40/HGC40D/DGC1)	1
26	00-355542-00001	Blower Baffle (SST)	1
27	00-357507-00001	Seal - Door (30½ Long)	2
28	SD-034-31	Self-Tapping Screw 6-20 x 5/16 Phil. Pan Hd., Type T	14
29	00-342132-00004	Guard-Thermostat Bulb (HGC40/HGC40D/HGC60/HGC60D)	1
30	00-342132-00002	Guard-Thermostat Bulb (DGC1)	1
31	00-354319-00001	Probe Assy. (HGC40/HGC60)	1
32	00-920883-00002	Probe-Thermocouple W/40" Leads (HGC40D/HGC60D)	1
33	00-342154-00002	Plug - Thermostat	1
34	00-340445-00002	Leg - Adjustable (6")	AR
35	00-342150-00005	Leg - Adjustable (8")	AR
36	00-358255-00002	Leg (20¼" High)(DGC1)	AR
37	00-358255-00001	Leg (24½" High)(DGC1)	AR
38	00-343634-00001	Caster - (Swivel)(W/Brake)(7½")	2
39	00-341655-00006	Caster - 6" High (Swivel)(W/Brake)	AR
40	00-410118-00017	Caster (Swivel W/Brake)(6⅞" High)(5" Dia.)(HGC40D/HGC60/HGC60D/DGC1)	2
41	00-343634-00002	Caster - 7½" High (Rigid)	2
42	00-341655-00007	Caster (6" High)(Rigid)(HGC40/HGC60/HGC60D/DGC1)	AR
43	00-410118-00016	Caster (6⅞" High)(5" Dia.)(Swivel W/O Brake (HGC40D/HGC60/HGC60D/DGC1)	AR
44	00-407729-00003	Foot-Bullet (1" to 2¾") (HGC40D/HGC60D/DGC1)	AR
45	FE-023-53	Bushing - Snap	2
46	00-358476-00001	Leg W/Feet (SST)(Incls. item 44 & Leg)(HGC40D/HGC60D/DGC1)	AR
47	00-358476-00002	Leg W/Caster (W/Brake)(SST)(Incls. item 40 & Leg)(HGC40D/HGC60/HGC60D/DGC1)	AR
48	00-358476-00003	Leg W/Caster (W/O Brake)(SST)(Incls. item 43 & Leg)(HGC40D/HGC60/HGC60D/DGC1)	AR
49	00-340412-00001	Brace - Leg	4
50	00-346358-00002	Hi-Limit Assy.	1

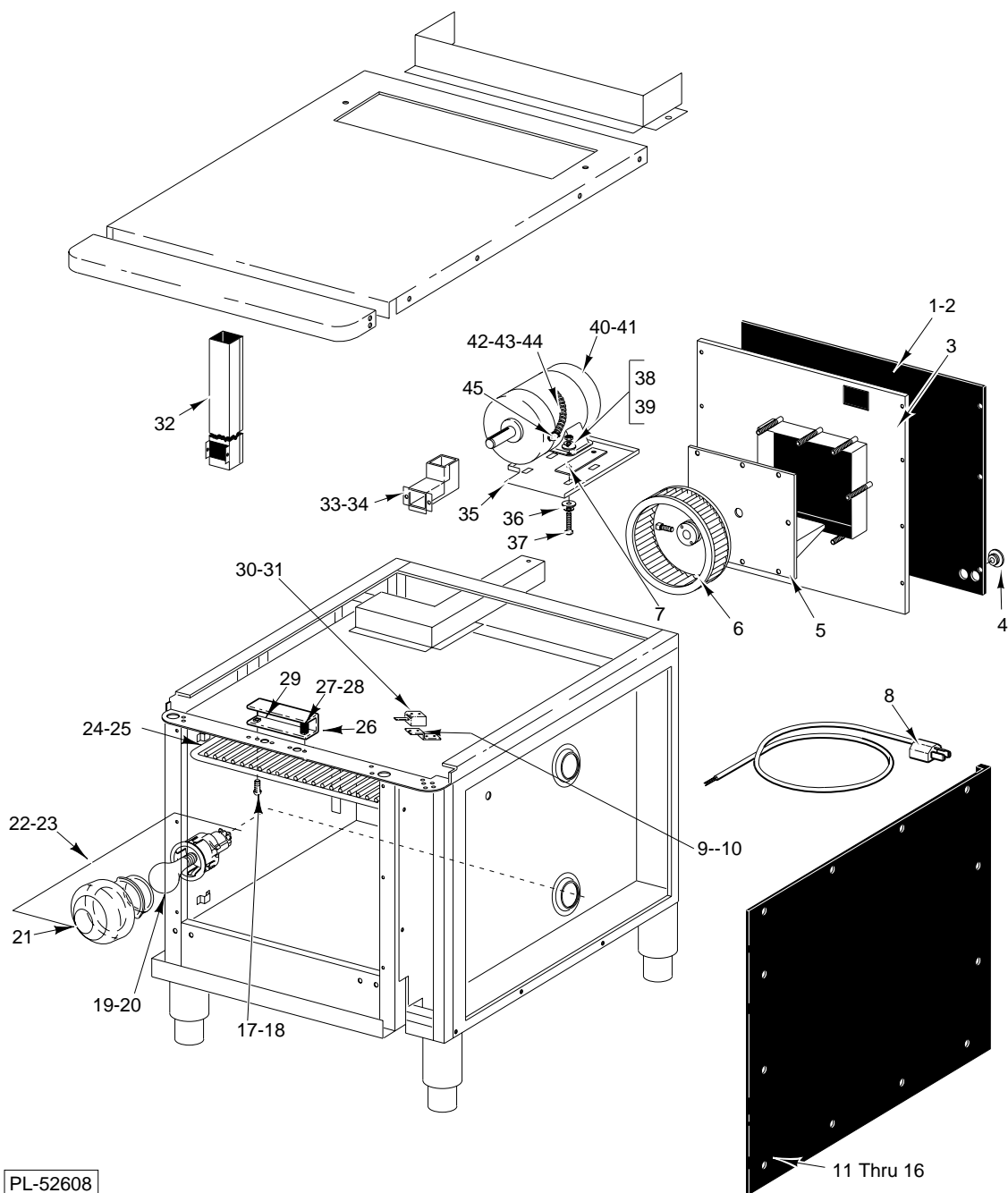

PL-52608

OVEN (R.H.)

OVEN (R.H.)

ILLUS. PL-52608	PART NO.	NAME OF PART	AMT.
1	00-358473-00001	Panel-Back (PTD)(HGC40/HGC60/HGC60D/DGC1)	1
2	00-358473-00002	Panel - Back (SST)	1
3	00-354960-00001	Back - Inner Panel	1
4	00-355023-00001	Bushing - Snap	1
5	00-356633-00001	Motor Mount	1
6	00-358638-00001	Wheel-Blower (Incls. 5/16-24 UNF SST Sq. Hd. Bolt)	1
7	00-358723-00001	Spacer - Steel	2
8	00-405016-00001	Cord-Electric Supply	1
9	SD-034-47	Self-Tapping Screw 6-32 x 1 Hex Washer Hd., Type T	2
10	00-343509-00001	Bracket - Door Switch	1
11	00-358480-00001	Panel-Outer (R.H.)(PTD)(HGC40/DGC1)	1
12	00-358480-00002	Panel-Outer (R.H.)(SST)(HGC40/HGC40D/DGC1)	1
13	00-359515-00001	Panel-Outer (R.H.)(PTD)(HGC60/HGC60D)	1
14	00-359515-00002	Panel-Outer (R.H.)(SST)(HGC60/HGC60D)	1
15	00-359516-00001	Panel-Outer (L.H.)(PTD)(HGC60/HGC60D)	1
16	00-359516-00002	Panel-Outer (L.H.)(SST)(HGC60/HGC60D)	1
17	SC-114-01	Mach. Screw 10-32 x 3/8 Hex Washer Hd., Slotted (DGC1)	2
18	NS-046-88	Nut Assy. 10-32 Hex "KEPS" (DGC1)	2
19	00-342766-00001	Bulb-Oven Light (40 Watts)(120V(DGC1)	2
20	00-342766-00002	Bulb-Oven Light (40 Watts)(240V(DGC1)	2
21	00-357036-00003	Lens-Oven Lamp (DGC1)	2
22	00-357036-00001	Lamp-Oven (120/130V., 40 Watts)(Incls. items 25 & 27)	2
23	00-357036-00002	Lamp-Oven (250V., 40 Watts)(Incls. item 26 & 27)	2
24	00-342142-00001	Rack Assy. (HGC40/HGC40D/DGC1)	AR
25	00-342142-00002	Rack Assy. (HGC60/HGC60D)	AR
26	00-355344	Channel-Latch (DGC1)	1
27	00-417810-00003	Spring-Compression (DGC1)	2
28	SC-022-40	Mach. Screw 1/4-20 x 3/4 Phil. Flat Hd(DGC1)	2
29	00-411794-00001	Catch-Door (DGC1)	2
30	00-342147-00001	Switch - Door	1
31	SD-034-62	Self-Tapping Screw 10-32 x 1/2 Hex Washer Hd., Type T	2
32	00-355108-00001	Vent Assy. - Common (Stacked Units)	1
33	00-354975-00001	Flue Deflector Assy.	1
34	SD-034-45	Self-Tapping Screw 6-32 x 3/8 Rd. Hd., Type T	2
35	00-345523-00001	Baffle - Motor	1
36	WS-029-46	Washer	4
37	SC-113-65	Cap Screw 5/16-18 x 1 1/4 Hex Hd.	4
38	NS-046-86	Nut Assy. 5/16-18 "KEPS" Hex	4
39	WS-029-46	Washer	4
40	00-358516-00001	Motor 1/3 Hp (2 Speed)(115, 50/60 Hz., 1 Ph.)	1
41	00-358516-00002	Motor 1/3 Hp. (2 Speed)(208-230, 50/60 Hz., 1 Ph.)	1
42	00-342285-00001	Bushing - Plastic	2
43	FE-006-05	Lock Nut 3/4	1
44	00-342151-00001	Conduit	1
45	FE-002-52	Connector - Conduit 3/8 TS 90 Deg.	1
	00-355319-00001	Flue-Common (Stacked Units)(Packaged)(Not Shown)	1
	00-355318-00002	Pan-Drip (HGC40/HGC40D/DGC1)(Packaged)(Not Shown)	1
	00-355318-00003	Pan-Drip (HGC60/HGC60D)(Packaged)(Not Shown)	1
	00-342552-00001	Stand Assy. (Open Stand)(32 3/16")(HGC40/HGC40D/DGC1)(Not Shown)	1
	00-342552-00002	Stand Assy.(Frame for Cabinet Base)(32 3/16")(HGC40/HGC40D/DGC1)(Not Shown)	1
	00-342552-00003	Stand Assy.(Open Stand)(40 9/16")(HGC60/HGC60D)(Not Shown)	1
	00-342552-00004	Stand Assy.(Frame for Cabinet Base)(40 9/16")(HGC60/HGC60D)(Not Shown)	1

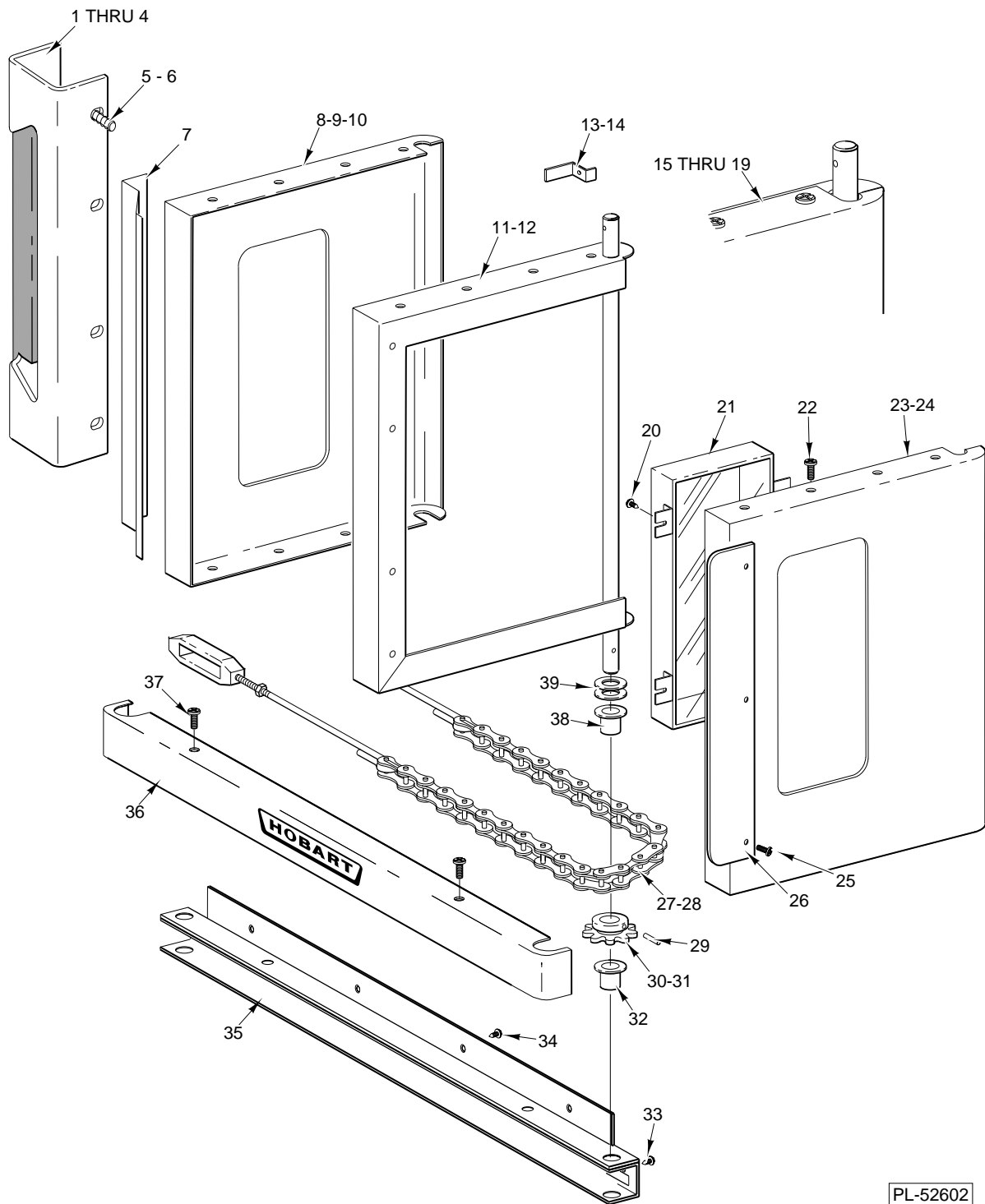

DOOR
HGC40/HGC40D/HGC60/HGC60D

DOOR
HGC40/HGC40D/HGC60/HGC60D

ILLUS. PL-52602	PART NO.	NAME OF PART	AMT.
1	00-356562-00001	Handle - Door	1
2	00-356563-00001	Grip - Front	1
3	00-356563-00002	Grip - Rear	1
4	SC-113-98	Mach. Screw 10-24 x ½ Hex Washer Hd.	3
5	SC-041-01	Cap Screw ¼-20 x ¾ Hex Hd	4
6	WL-019-22	Lockwasher ¼ Ext.	4
7	00-356550-00001	Latch - Friction	1
8	00-358545-00001	Shell - Outer Door (LH)(W/Window)	1
9	00-358545-00002	Shell-Outer Door (LH) (W/O Window)	1
10	00-358549-00001	Shell-Outer Door (RH) (Solid)	1
11	00-358551-00001	Frame Assy. - Door (LH)	1
12	00-358552-00001	Frame Assy. - Door (RH)	1
13	00-356253-00001	Lever - Door Switch	1
14	SD-034-52	Self-Tapping Screw 8-32 x 1 Hex Washer Hd., Type T	1
15	00-358544-00001	Door Assy. (LH)(W/Window)(HGC40/HGC60/HGC60D)	1
16	00-358544-00002	Door Assy. (LH)(W/Window)	1
17	00-358548-00001	Door Assy. (RH) (W/Window)	1
18	00-358543-00001	Door Assy. (W/Window)(HGC40/HGC60/HGC60D)	1
19	00-358543-00002	Door Assy. (W/O Window)	1
20	SD-034-62	Self-Tapping Screw 10-32 x ½ Hex Washer Hd., Type T	4
21	00-358534-00002	Window-Door (HGC40/HGC60/HGC60D)	1
22	00-350543-00006	Mach. Screw 10-32 x ½ Phil. Pan Hd.	9
23	00-358546-00001	Shell-Inner Door (W/Window)(HGC40/HGC60/HGC60D)	1
24	00-358550-00001	Shell - Inner Door (Solid)	1
25	00-350543-00006	Mach. Screw 10-32 x ½ Phil. Pan Hd.	3
26	00-357837-00001	Seal - Door End	1
27	00-343608-00002	Door Chain & Turnbuckle Assy.	2
28	00-352667-00001	Door Stop Cable Assy. (Use with item 27)	1
29	PS-004-11	Spirol Pin ⅜ x 1¼	2
30	00-342166-00001	Sprocket - Door Shaft	2
31	SC-047-28	Set Screw ¼-28 x ⅜ Hex Hdls. Cup Pt.	2
32	00-347080-00002	Bearing - Door Shaft	2
33	SC-113-90	Mach. Screw ¼-20 x ¾ Hex Hd.	2
34	SC-022-40	Mach. Screw ¼-20 x ¾ Phil. Flat Hd.	4
35	00-357846-00001	Channel - Door Sill Weldment	1
36	00-358558-00001	Front Cover - Door Sill	1
37	SD-034-59	Self-Tapping Screw 10-32 x ⅜ Phil. Pan Hd., Type T	2
38	00-347080-00002	Bearing - Door Shaft	2
39	00-343143-00001	Washer	4
	00-520228	Adhesive (Use with item 31)(50cc Bottle)	AR
	00-528664	Lubricant (Use with item 31)	AR

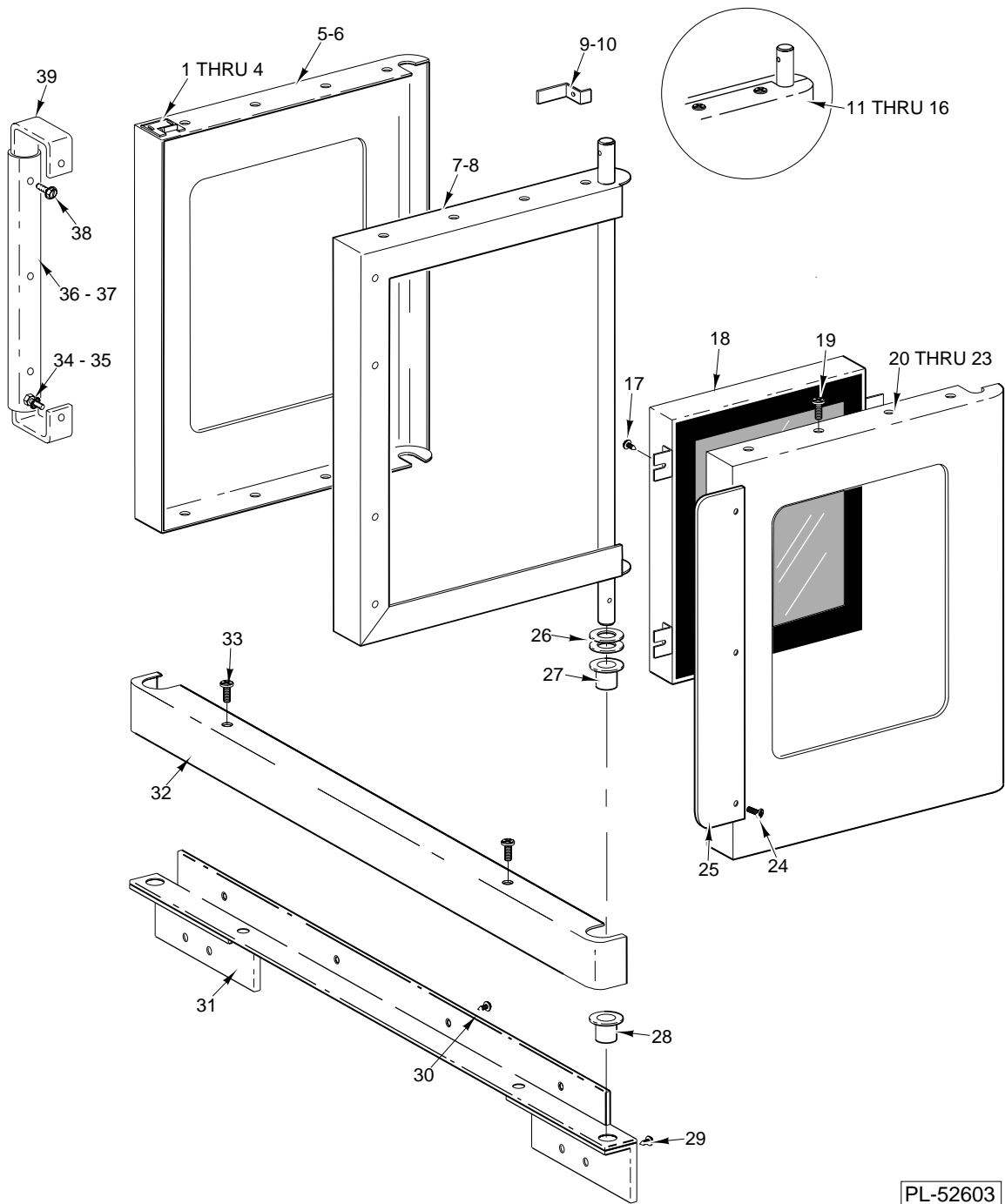

PL-52603

DOOR - DGC1

DOOR - DGC1

ILLUS. PL-52603	PART NO.	NAME OF PART	AMT.
1	00-357877-00001	Shim - Door Strike	2
2	00-358542-00001	Strike - Door	1
3	00-350543-00006	Mach. Screw 10-32 x 1/2 Phil. Pan Hd.	2
4	WL-019-35	Lockwasher 10 Int	2
5	00-358600-00001	Shell - Outer Door (RH)(W/Window)	1
6	00-358600-00002	Shell - Outer Door (RH)(W/O Window)(Not Shown)	1
7	00-357840-00002	Frame Assy. - Door (R.H.)	1
8	00-357841-00002	Frame Assy. - Door (L.H.)	1
9	00-356253-00001	Lever - Door Switch	1
10	SD-034-52	Self-Tapping Screw 8-32 x 1 Hex Washer Hd., Type T	1
11	00-358597-00001	Door Assy. (Incls. items 13, 15, 26 thru 31, 34, 35 & 39)	1
12	00-358597-00002	Door Assy. (Incls. items 14, 16, 26 thru 34, 35 & 39)	1
13	00-358598-00001	Door Assy. (LH)(W/Window)(Incls. items 1 thru 5,8,17,18,19,21,24 & 25)	1
14	00-358598-00002	Door Assy. (LH)(W/O Window)(Incls. items 1 thru 4,6,8,19,23,24 & 25)	1
15	00-358599-00001	Door Assy. (RH)(W/Window)(Incls. items 1 thru 5,7 & 17 thru 20)	1
16	00-358599-00002	Door Assy. (RH)(W/O Window)(Incls. items 1 thru 4,6,7,19 & 22)	1
17	SD-034-62	Self-Tapping Screw 10-32 x 1/2 Hex Washer Hd., Type T	4
18	00-358534-00002	Window Assy.	1
19	00-350543-00006	Mach. Screw 10-32 x 1/2 Phil. Pan Hd.	7
20	00-358532-00002	Shell - Inner Door (W/Window)(RH)	1
21	00-358532-00001	Shell - Inner Door (W/Window)(LH)	1
22	00-358533-00004	Shell - Inner Door (Solid)(RH)	1
23	00-358533-00003	Shell - Inner Door (Solid)(LH)	1
24	00-350543-00006	Mach. Screw 10-32 x 1/2 Phil. Pan Hd.	3
25	00-357837-00001	Seal - Door End	1
26	00-343143-00001	Washer	4
27	00-347080-00002	Bearing - Door Shaft	1
28	00-347080-00002	Bearing - Door Shaft	1
29	SC-113-90	Mach. Screw 1/4-20 x 3/4 Hex Hd.	2
30	SC-022-40	Mach. Screw 1/4-20 x 3/4 Phil. Flat Hd.	4
31	00-357873-00001	Sill - Bottom Weldment	1
32	00-358558-00001	Front Cover - Door Sill	1
33	SD-034-59	Self-Tapping Screw 10-32 x 3/8 Phil. Pan Hd., Type T	2
34	SC-041-01	Cap Screw 1/4-20 x 3/4 Hex Hd	2
35	WL-019-37	Lockwasher 1/4 Int.	2
36	00-356563-00001	Grip - Front	1
37	00-356563-00002	Grip - Rear	1
38	SC-113-98	Mach. Screw 10-24 x 1/2 Hex Washer Hd.	3
39	00-357929-00001	Handle-Door (Incls. items 36, 37 & 38)	1

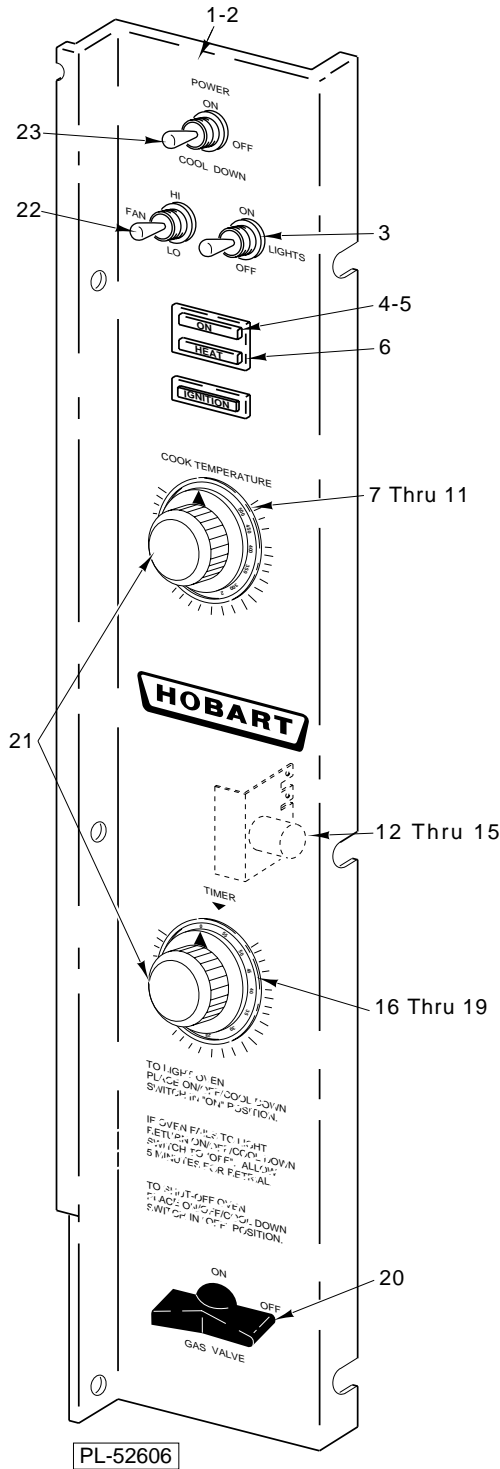

HGC-40/HGC60

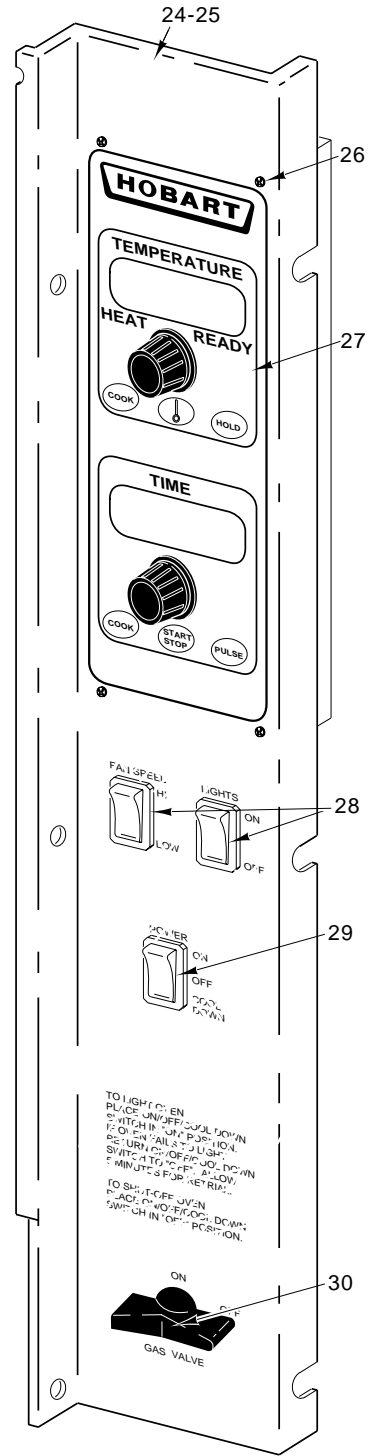

HGC-40D/HGC60D

CONTROL PANEL
HGC40/HGC40D/HGC60/HGC60D

**CONTROL PANEL
HGC40/HGC40D/HGC60/HGC60D**

ILLUS. PL-52606	PART NO.	NAME OF PART	AMT.
1	00-358626-00001	Panel-Control (HGC40/HGC60)	1
2	00-358535-00001	Overlay (HGC40/HGC60)	1
3	00-340324-00012	Switch (S.P.S.T.)(On/Off)(HGC40/HGC60)	1
4	00-354575-00001	Light-Indicator (On/Heat)(200-240V)(HGC40/HGC60)	1
5	00-354575-00002	Light-Indicator (On/Heat)(110-120V)(HGC40/HGC60)	1
6	00-354575-00004	Light-Indicator (No Ignition)(HGC40/HGC60)	1
7	00-358539-00001	Plate-Temperature Dial (500 Deg. F)(HGC40/HGC60)	1
8	00-358539-00002	Plate-Temperature Dial (HGC40/HGC60)	1
9	00-353613-00002	Controller-Temperature (500 Deg. F) HGC40/HGC60)	1
10	SC-114-83	Mach. Screw 6-32 x ¼ Pan Hd.	2
11	WS-028-20	Washer	2
12	00-411499-00004	Buzzer (115V) (HGC40/HGC60)	1
13	00-411499-00003	Buzzer (230V) (HGC40/HGC60)	1
14	SD-034-49	Self-Tapping Screw 8-32 x ½ Hex Washer Hd., Type T	1
15	WL-014-10	Lockwasher ¼ Ext. "Shakeproof"	1
16	00-411690-00001	Timer (110-120V)(1 Hr.)(HGC40/HGC60)	1
17	00-411690-00002	Timer (200-240V)(1 Hr.)(HGC40/HGC60)	1
18	00-411690-00005	Timer (240-50)(1 Hr.)(HGC40/HGC60)	1
19	00-358538-00001	Plate-Dial Timer (HGC40/HGC60)	1
20	00-402957-00003	Handle - Gas Cock (Black)	1
21	00-411242-00001	Knob (HGC40/HGC60)	2
22	00-340324-00009	Switch (D.P.D.T.)(2 Speed Motor)(On/On)(HGC40/HGC60)	1
23	00-340324-00008	Switch (D.P.D.T.)(On/Off/On)(HGC40/HGC60)	1
24	00-355892-00001	Panel-Control (HGC40D/HGC60D)	1
25	00-355893-00001	Overlay-Panel (HGC40D/HGC60D)	1
26	NS-011-07	Mach. Nut 6-32 Hex (HGC40D/HGC60D)	4
27	00-355903-00005	Control-Electronic Oven (HGC40D/HGC60D)	1
28	00-358628-00002	Switch-Rocker (2 Position)(HGC40D/HGC60D)	2
29	00-358628-00001	Switch-Rocker (3 Position)(HGC40D/HGC60D)	1
30	00-402957-00003	Handle-Gas Cock (Black)(HGC40D/HGC60D)	1

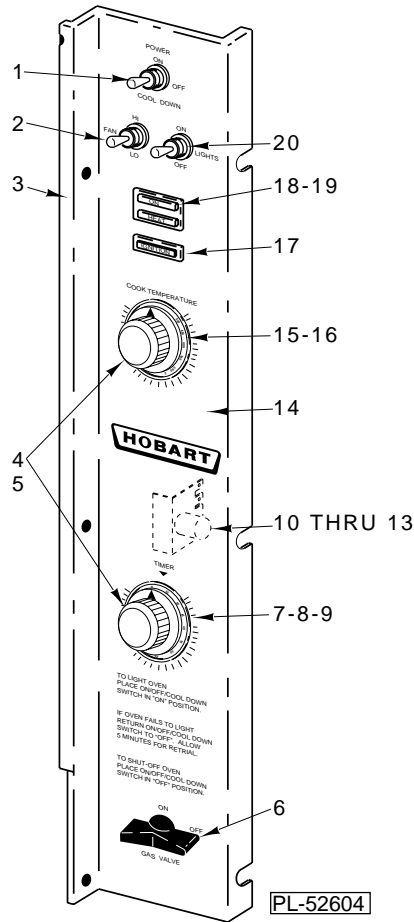

CONTROL PANEL - DGC1

CONTROL PANEL - DGC1

ILLUS. PL-52604	PART NO.	NAME OF PART	AMT.
1	00-340324-00011	Switch (4 P.D.T.)(480 V.)(1 Speed Motor)	1
2	00-340324-00009	Switch (D.P.D.T.)	1
3	00-358626-00001	Panel-Control	1
4	00-411242-00001	Knob	2
5	SC-109-10	Mach. Screw 6-32 x 3/8 Pan Hd.	2
6	00-402957-00003	Handle - Gas Cock (Black)	1
7	00-411690-00001	Timer (110-120 V.)(1 Hr.)	1
8	00-411690-00002	Timer (200-240 V.)(1 Hr.)	1
9	00-411690-00005	Timer 120V (1 Hr)(50Hz)	1
10	00-411499-00003	Buzzer (230 V.)	1
11	00-411499-00004	Buzzer (115 V.)	1
12	SD-034-62	Self-Tapping Screw 10-32 x 1/2 Hex Washer Hd., Type T	1
13	WL-014-10	Lockwasher 1/4 Ext. "Shakeproof"	1
14	00-358535-00001	Overlay	1
15	00-411506-00003	Thermostat (Convection Oven)	1
16	00-358539-00002	Plate - Dial Temperature (Centigrade)	1
17	00-354575-00004	Light - Indicator (No Ignition)	1
18	00-354575-00002	Light - Indicator (On/Heat)(110-120V.)	1
19	00-354575-00001	Light Indicator (On/Heat) (200-240V)	1
20	00-340324-00012	Switch (S.P.S.T.)	1

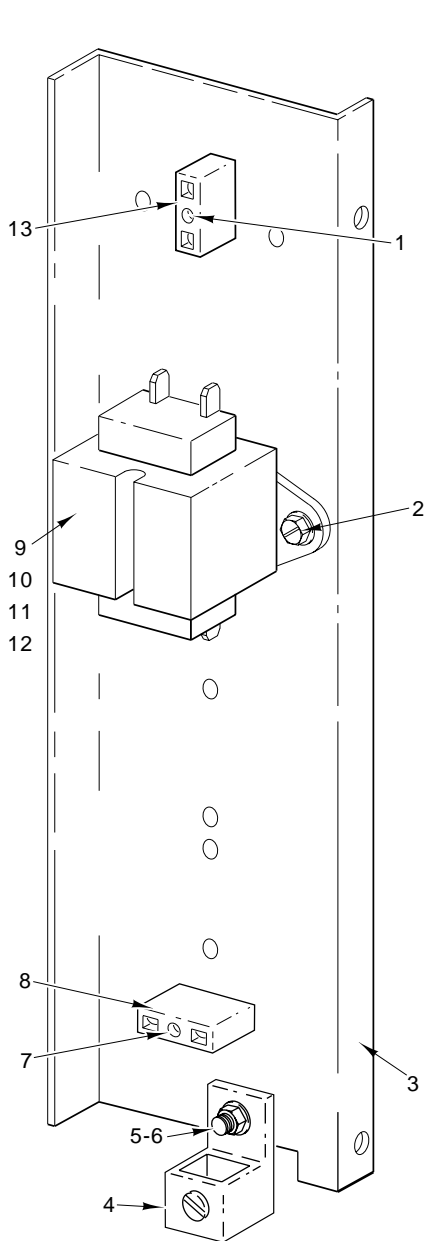

HGC-40/HGC60/DGC1

PL-52605

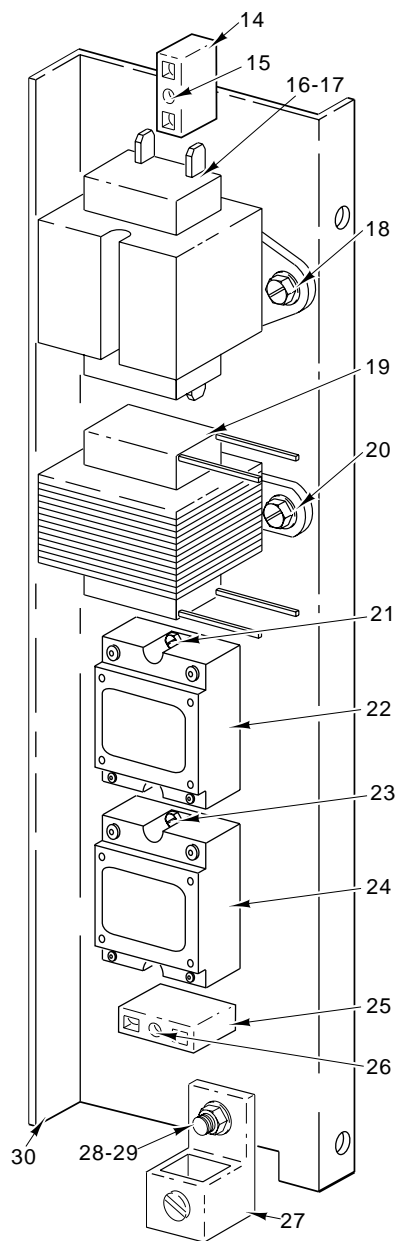

HGC-40D/HGC60D

**ELECTRICAL COMPONENT PANEL
(ALL MODELS)**

ELECTRICAL COMPONENT PANEL (ALL MODELS)

ILLUS. PL-52605	PART NO.	NAME OF PART	AMT.
1	SD-034-52	Self-Tapping Screw 8-32 x 1 Hex Washer Hd., Type T	1
2	SD-034-49	Self-Tapping Screw 8-32 x 1/2 Hex Washer Hd., Type T	2
3	00-358705-00001	Panel - Component	1
4	00-417856-00001	Lug - Grounding (With Set Screw)	1
5	SC-114-03	Mach. Screw 10-32 x 1/2 Hex Washer Hd.	1
6	NS-046-88	Nut Assy. 10-32 HEX "KEPS"	1
7	SD-034-52	Self-Tapping Screw 8-32 x 1 Hex Washer Hd., Type T	1
8	00-417934-000G1	Porcelain - Block Assy.	1
9	00-421758-000G1	Transformer (120V)(HGC40/HGC60/HGC60D/DGC1)	1
10	00-421758-000G2	Transformer (208-240 V)	1
11	00-411500-00012	Transformer (120VAC, 28V., 20VA)(DGC1)	1
12	00-411500-00013	Transformer (200-240VAC, 28V., 20VA)(DGC1)	1
13	00-417934-000G1	Porcelain - Block Assy.	1
14	00-417934-000G1	Porcelain - Block Assy.	1
15	SD-034-52	Self-Tapping Screw 8-32 x 1 Hex Washer Hd., Type T	1
16	00-421758-000G1	Transformer (120V)(HGC40/HGC60/HGC60D/DGC1)	1
17	00-421758-000G2	Transformer (208-240V)	1
18	SD-034-49	Self-Tapping Screw 8-32 x 1/2 Hex Washer Hd., Type T	2
19	00-358629-00001	Transformer (120V)(HGC40D/HGC60D)	1
20	SD-034-49	Self-Tapping Screw 8-32 x 1/2 Hex Washer Hd., Type T	2
21	SD-034-49	Self-Tapping Screw 8-32 x 1/2 Hex Washer Hd., Type T	2
22	00-821875-00003	Relay-Solid State (10 Amp)	1
23	SD-034-49	Self-Tapping Screw 8-32 x 1/2 Hex Washer Hd., Type T	2
24	00-821875-00002	Relay - Solid State (50Amp)	1
25	00-417934-000G1	Porcelain - Block Assy.	1
26	SD-034-52	Self-Tapping Screw 8-32 x 1 Hex Washer Hd., Type T	1
27	00-417856-00001	Lug - Grounding (With Set Screw)	1
28	SC-114-03	Mach. Screw 10-32 x 1/2 Hex Washer Hd.	1
29	NS-046-88	Nut Assy. 10-32 HEX "KEPS"	1
30	00-358705-00001	Panel - Component	1
	00-358718	Lead Set (Not Shown)	1
	00-358721	Lead Set (Not Shown) (DGC1)	1

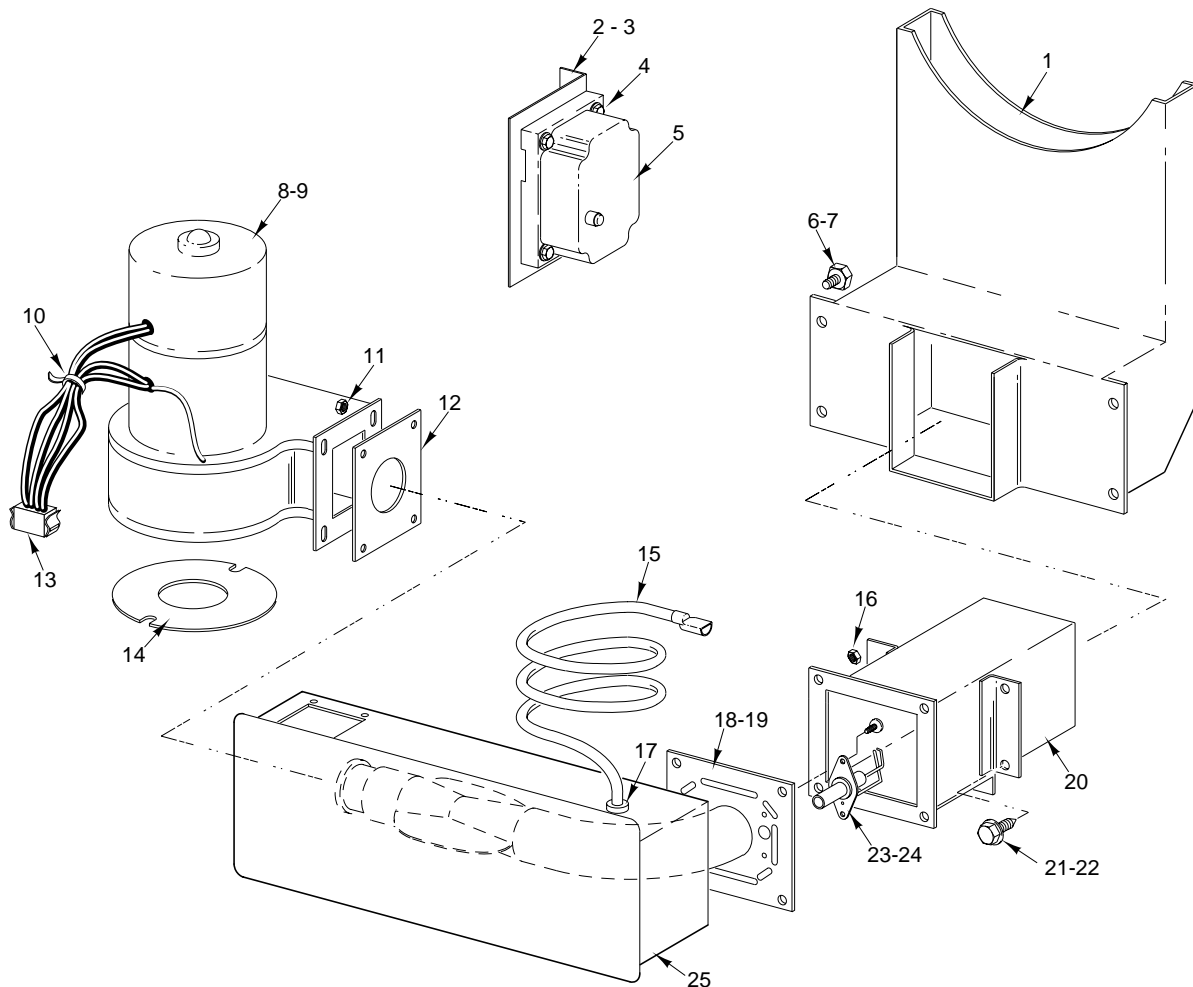

PL-52610

COMBUSTION ASSEMBLY

COMBUSTION ASSEMBLY

ILLUS. PL-52610	PART NO.	NAME OF PART	AMT.
1	00-356590-00001	Heat Exchanger Assy.	1
2	00-356594-00001	Bracket - Ignition Module	1
3	SD-034-21	Self-Tapping Screw 10-16 x ½ Sl. Hex Washer Hd., Type AB	2
4	SD-034-52	Self-Tapping Screw 8-32 x 1 Hex Washer Hd., Type T	4
5	00-356589-00002	Controller - Spark Ignitor	1
6	SD-037-80	Self-Tapping Screw 10-24 x ½ Hex Washer Hd., Typ	4
7	WL-006-06	Lockwasher 10 Light	4
8	00-354984-00001	Motor Blower Assy. (120V)(Incls. items 10, 13 & 14)	1
9	00-354984-00003	Motor Blower Assy. (230V)(Incls. items 10, 13 & 14)	1
10	00-251199	Tie - Cable (4" Long)	3
11	NS-046-52	Nut - ¼-20 Hex "Keps"	1
12	00-355017-00001	Gasket - Blower Motor	1
13	00-345519-00002	Plug (Natural)(12 Circuits)	1
14	00-355047-00001	Restrictor - Blower Plate (1¼ Dia. Hole)	1
15	00-356595-00001	Cable - High Voltage	1
16	NS-046-52	Nut - ¼-20 Hex "Keps"	4
17	FE-016-23	Bushing	1
18	00-356571-00002	Burner Assy.	1
19	00-356586-00001	Insulation - Burner	1
20	00-356579-00001	Box - Combustion	1
21	SC-053-41	Mach. Screw ¼-20 x ½ Truss Hd. SST	4
22	WL-006-17	Lockwasher ¼ Medium	4
23	00-356587-00001	Electrode - Ignition	1
24	SD-036-17	Self-Tapping Screw 8-18 x ¾ Phil. Pan Hd., Type	2
25	00-356576-00001	Burner Box Assy.	1

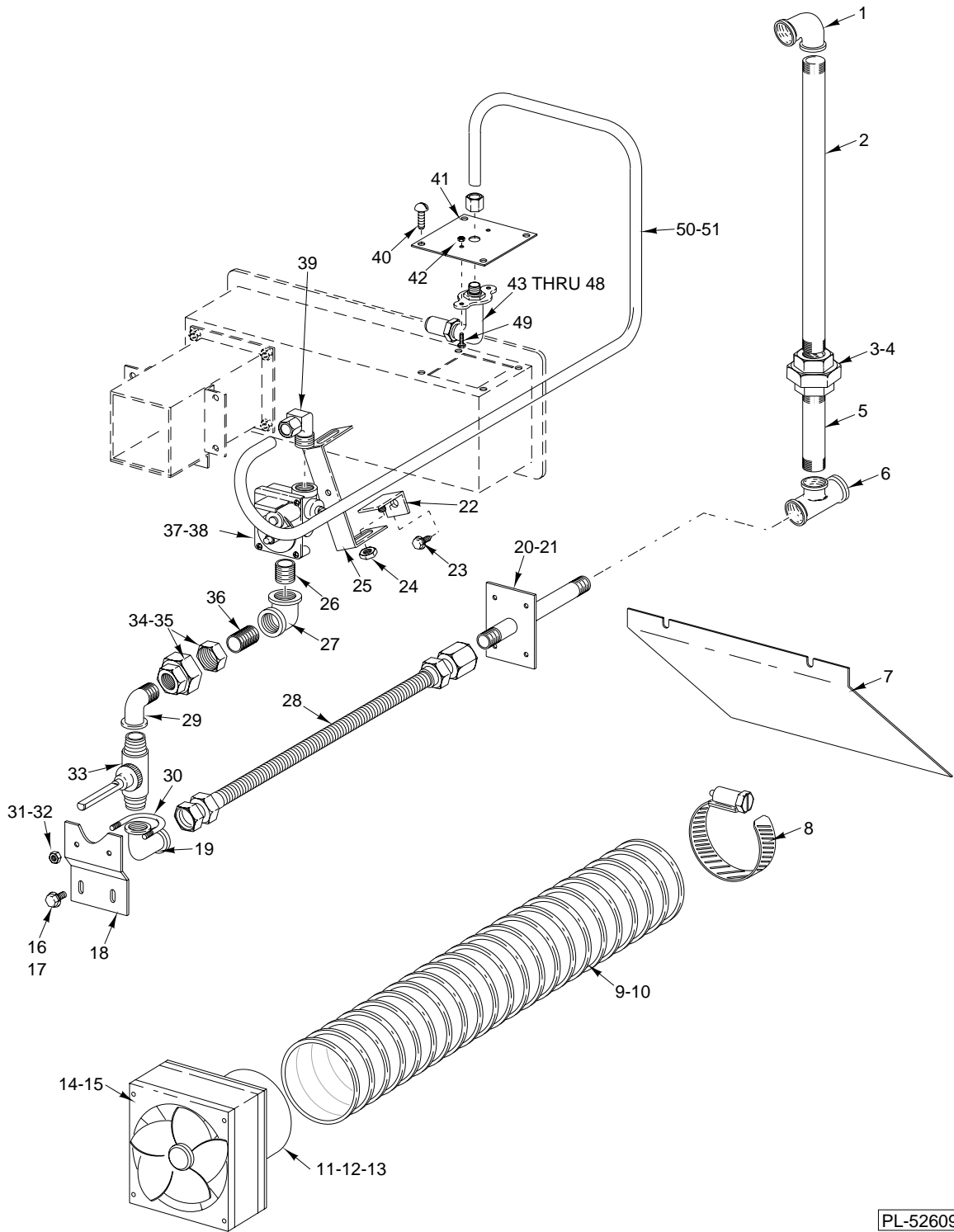

PL-52609

GAS PIPING

GAS PIPING

ILLUS. PL-52609	PART NO.	NAME OF PART	AMT.
1	FP-077-68	Elbow 1/2 x 90 Deg.	1
2	FP-075-27	Nipple 1/2 x 21 T.B.E.	1
3	FP-022-11	Union - Pipe	1
4	00-348069-00002	Union-Straight (DGC1)	1
5	FP-058-51	Nipple 1/2 x 5 TBE	1
6	FP-019-25	Tee 1/2 x 1/2 x 1/2	1
7	00-358490-00001	Shield - Exhaust Tube (Mount to Back Panel)	1
8	00-521462	Clamp - Hose	2
9	00-355726-00002	Tube-Exhaust (28") (HGC40/HGC40D/DGC1)	1
10	00-355726-00003	Tube-Exhaust (36") (HGC60/HGC60D)	1
11	00-355724-00001	Tube - Bracket Assy.	1
12	SC-021-10	Mach. Screw 6-32 x 1/2 Rd. Hd.	6
13	NS-046-89	Nut Assy. 6-32 Hex "KEPS"	6
14	00-415207-00001	Fan - Cooling (120 V.)	1
15	00-415207-00002	Fan Cooling (230 V.)	1
16	SC-041-01	Cap Screw 1/4-20 x 3/4 Hex Hd.	2
17	WL-006-17	Lockwasher 1/4 Medium	2
18	00-356735-00001	Support - Valve	1
19	FP-087-19	Elbow - Reducing 1/2 x 3/8 x 90 Deg. Brass	1
20	00-356738-00001	Pipe-Weldment Gas Inlet (HGC40/HGC40D/DGC1)	1
21	00-356738-00002	Pipe-Weldment Gas Inlet (HGC60/HGC60D)	1
22	00-356638-00001	Bracket - Solenoid	1
23	SD-036-51	Self-Tapping Screw 8-32 x 3/8 Hex Washer Hd., Type T	2
24	NS-046-52	Nut - 1/4-20 Hex "Keps"	2
25	00-356637-00001	Support - Solenoid	1
26	FP-035-46	Pipe 3/8 x 1 Lg. (T.B.E)	1
27	FP-013-11	Elbow 3/8 x 90 Deg.	1
28	00-356737-00001	Tube - Flex (24"Lg.)	1
29	FP-078-75	Street Elbow 3/8 x 90 Deg.	1
30	00-521820	"U" Bolt 1/4-20	1
31	NS-015-01	Full Nut 1/4-20 Hex SST	2
32	WL-006-17	Lockwasher 1/4 Medium	2
33	00-407789-00003	Valve - Service	1
34	00-348049-00201	Union (Tail & Nut)	1
35	00-348049-00101	Union (Head)	1
36	FP-035-52	Nipple 3/8 x 2 TBE	1
37	00-354344-00004	Valve - Gas Control (Natural)	1
38	00-354344-00005	Valve - Gas Control (Propane)	1
39	FP-085-68	Fitting-Tube 7/16	1
40	SD-034-15	Self-Tapping Screw 8-18 x 3/8 Rd. Hd., Type AB	4
41	00-356584-00001	Plate - Orifice	1
42	NS-044-09	Nut Assy. 10-24 Hex Keps	2
43	00-356585-00001	Fitting-Orifice (29 Drill)(Nat)(Sea Level to 2499')(HGC40/HGC60/HGC60D/DGC1)	1
44	00-356585-00002	Fitting - Orifice (30 Drill)(Nat)(2500 to 6499 Ft)	1
45	00-356585-00003	Fitting - Orifice (31 Drill)(Nat)(6500 to 7499 Ft)	1
46	00-356585-00004	Fitting - Orifice (48 Drill)(PRO)(Sea Level to 2499 Ft)	1
47	00-356585-00005	Fitting - Orifice (49 Drill)(PRO)(2500 to 6499 Ft)	1
48	00-356585-00006	Fitting - Orifice (50 Drill)(PRO)(6500 to 7499 Ft)	1
49	SC-119-31	Mach. Screw 10-24 x 3/8 Hex Hd SST	2
50	00-356588-00001	Tube-Gas Inlet (HGC40/HGC40D/DGC1)	1
51	00-356588-00002	Tube-Gas Inlet (HGC60/HGC60D)	1