



ENDURANCE / CHALLENGER MODULAR SERIES GAS RANGES



VULCAN 12
24S
36S, 36C
48C, 48S, 48SS
60SS, 60SC, 60CS
72SS, 72SC, 72CC, 72CS

WOLF C12,
C24S
C36S, C36C
C48S, C48SS, C48C
C60SS, C60SC, C60CS
C72SS, C72SC, C72CC, C72CS

This Manual is prepared for the use of trained Vulcan Service Technicians and should not be used by those not properly qualified.

This manual is not intended to be all encompassing. If you have not attended a Vulcan Service School for this product, you should read, in its entirety, the repair procedure you wish to perform to determine if you have the necessary tools, instruments and skills required to perform the procedure. Procedures for which you do not have the necessary tools, instruments and skills should be performed by a trained Vulcan Service Technician.

The reproduction, transfer, sale or other use of this Manual, without the express written consent of Vulcan, is prohibited.

This manual has been provided to you by ITW Food Equipment Group LLC ("ITW FEG") without charge and remains the property of ITW FEG, and by accepting this manual you agree that you will return it to ITW FEG promptly upon its request for such return at any time in the future.

For additional information on Vulcan-Hart Company or to locate an authorized parts and service provider in your area, visit our website at www.vulcanequipment.com

TABLE OF CONTENTS

GENERAL	4
INTRODUCTION	4
INSTALLATION, OPERATION AND CLEANING	4
LUBRICATION	4
TOOLS	4
SPECIFICATIONS	4
REMOVAL AND REPLACEMENT OF PARTS	5
MANIFOLD COVER	5
CONTROL BRACKET COVER	5
CONTROL PANEL (30" OVENS)	5
KICK PANEL (24" & 30" OVENS)	5
BULL NOSE	6
CONTROL BRACKET	6
STANDARD OVEN PILOT ASSEMBLY AND THERMOCOUPLE	7
STANDARD OVEN BURNER	7
STANDARD OVEN THERMOSTAT (24" OVEN)	8
STANDARD OVEN THERMOSTAT (30" OVEN)	9
CONVECTION OVEN PILOT ASSEMBLY AND THERMOCOUPLE	10
CONVECTION OVEN BURNER	11
CONVECTION OVEN THERMOSTAT-COMBO VALVE	11
CONVECTION OVEN BLOWER AND MOTOR	12
BURNER ORIFICE HOOD (STANDARD AND CONVECTION OVENS)	13
GAS SAFETY VALVE (STANDARD AND CONVECTION OVENS)	13
TOP BURNER PILOT VALVE	14
TOP BURNER ASSEMBLY	15
TOP BURNER CONTROL VALVE	15
TOP BURNER ORIFICE HOOD	16
OVEN DOOR	16
GAS PRESSURE REGULATOR	17
CONVECTION OVEN DOOR SWITCH	18
CONVECTION OVEN SOLENOID	18
GRIDDLE THERMOSTAT-COMBO VALVE	19
GRIDDLE GAS SAFETY VALVE	21
GRIDDLE PILOT ASSEMBLY AND THERMOCOUPLE	21
GRIDDLE BURNER ORIFICE HOOD	22
SERVICE PROCEDURES AND ADJUSTMENTS	23
PILOT FLAME HEIGHT	23
OVEN PILOT ADJUSTMENT	23
OPEN TOP PILOT ADJUSTMENT	23
BURNER AIR SHUTTER ADJUSTMENT	23
REGULATOR ADJUSTMENT	24
BURNER NOZZLE CHECK	25
STANDARD OVEN THERMOSTAT BY-PASS FLAME ADJUSTMENT	25
STANDARD OVEN THERMOSTAT TEMPERATURE ADJUSTMENT	25
CONVECTION OVEN THERMOSTAT-COMBO VALVE ADJUSTMENT	26
OPERATION	26
ADJUSTMENT	26
GRIDDLE THERMOSTAT-COMBO VALVE ADJUSTMENT	27
OPERATION	27
ADJUSTMENT	27
THERMOCOUPLE TEST	27
OPERATION	27
PILOT CHECKS	27
THERMOCOUPLE CHECKS	27

ELECTRICAL OPERATION	29
COMPONENT FUNCTION	29
SEQUENCE OF OPERATION - CONVECTION OVEN	29
SCHEMATIC DIAGRAM - CONVECTION OVENS	30
WIRING DIAGRAM - CONVECTION OVENS	31
TROUBLESHOOTING	32
TROUBLESHOOTING	32

GENERAL

INTRODUCTION

This manual is for the **Endurance / Challenger XL™** Modular Series Gas Ranges. Procedures in this manual will apply to all models unless specified. Pictures and illustrations will be of model 60SC unless otherwise noted.

All of the information, illustrations and specifications contained in this manual are based on the latest product information available at the time of printing.

INSTALLATION, OPERATION AND CLEANING

Refer to F38201 VULCAN ENDURANCE / WOLF CHALLENGER Modular Series Gas Restaurant Ranges I/O Manual for detailed installation, operation and cleaning instructions.

LUBRICATION

Anderson and Forrester (or comparable) valve grease for top burner gas valves, top burner pilot valves, and pressure tap plugs. Apply light coat to valve/plug threads. Valve grease must be insoluble in propane and natural gas.

TOOLS

Standard

- Standard set of hand tools.
- VOM with A.C. current tester (Any quality VOM with a sensitivity of at least 20,000 ohms per volt can be used).

Special

- Temperature tester (K type thermocouple preferred).
- Manometer.
- Long reach phillips screwdriver #2 for installing or removing motor assembly through the convection oven cavity.
- Two standard 1/4"- 20 x 1" bolts (allen head recommended). The bolts are used to relieve spring tension on the door hinge during door removal and installation.
- Loctite® 246™ for use on the door handle mounting screws.

- Loctite® 242™ for sealing thermostat adjustment screw.
- Adaptor to test thermocouple closed circuit DC voltages (purchase locally). Adaptors vary between manufacturers. An example of one adaptor type is pictured below.

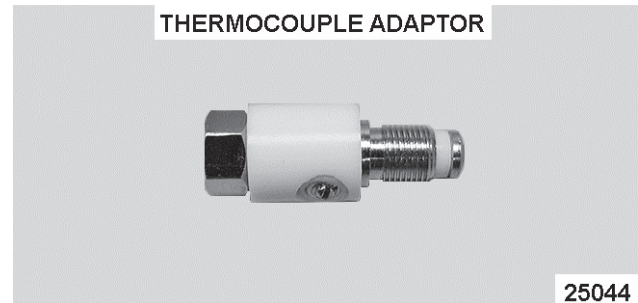

Fig. 1

SPECIFICATIONS

Gas Pressures

- Manifold/Operating Pressure
 - Natural: 5 in. W.C.
 - Propane: 10 in. W.C.
- Inlet Supply Pressure
 - Natural - Recommended 7 in. W.C. ; Minimum 5 in. W.C.
 - Propane - Recommended 11 in. W.C. ; Minimum 11 in. W.C.
 - Maximum 14 in. W.C. (0.5 PSI) (Natural or Propane)

Orifice Size Requirements

- See Orifice Chart in Parts Catalog F43260 ENDURANCE/CHALLENGER MODULAR SERIES GAS RANGES.

REMOVAL AND REPLACEMENT OF PARTS

MANIFOLD COVER

⚠ WARNING Shut off the gas before servicing the unit.

1. Pull crumb tray out.
2. Loosen set screw in the open top burner control knobs and remove knobs.
3. Remove screws that secure manifold cover and remove cover.
4. Reverse procedure to install.

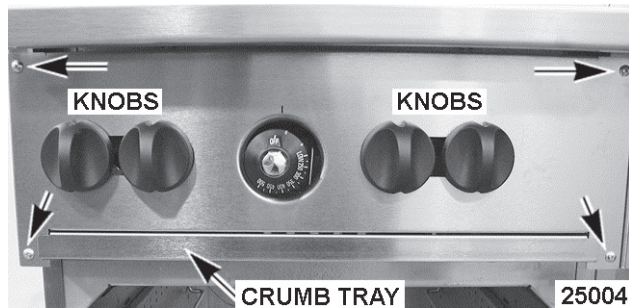

Fig. 2

CONTROL BRACKET COVER

⚠ WARNING Shut off the gas before servicing the unit.

1. Pull grease can out.
2. Pull knobs from thermostats.
3. If removing control bracket cover from oven with a 12" open top burner module and 24" griddle top module:
 - A. Pull crumb tray out of 12" section if installed.
 - B. Loosen set screw in the open top burner control knobs and remove knobs.
4. Remove screws that secure control bracket cover and remove the bracket.
5. Reverse procedure to install.

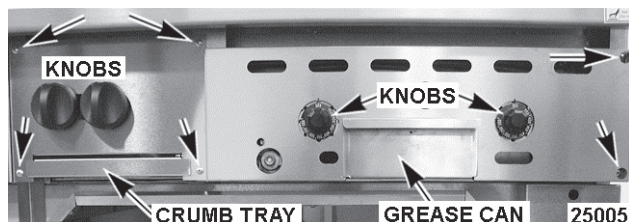

Fig. 3

CONTROL PANEL (30" OVENS)



⚠ WARNING Disconnect the electrical power to the machine and follow lockout / tagout procedures.

⚠ WARNING Shut off the gas before servicing the unit.

NOTE: Electrical power disconnect warning applies to convection ovens.

NOTE: Removal procedure applies to standard and convection 30" ovens.

1. Pull knob from thermostat.
2. Remove hole plug at top of control panel.
3. Remove screw and lift off control panel.
4. On convection ovens only, note lead wire locations and disconnect from power switch.
5. Reverse procedure to install.



Convection Oven Panel Shown

KICK PANEL (24" & 30" OVENS)

⚠ WARNING Shut off the gas before servicing the unit.

1. Lift up on kick panel and rotate down 90°.

2. Remove screws securing kick panel mounting brackets (2) to the oven and remove kick panel.
3. Reverse procedure to install.

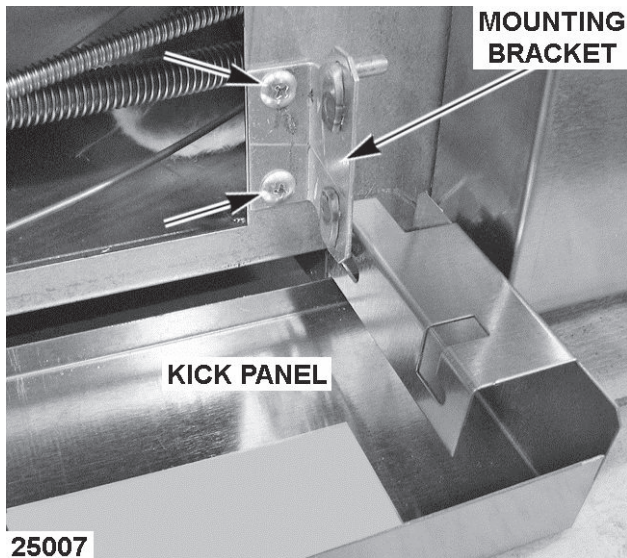

Fig. 5

BULL NOSE

1. Turn top burners and griddle off.
2. Remove front row of top burner grates on ranges with open top burners.
3. Remove all screws securing bull nose to range. The total number of screws depend on the width of the range.
4. Lift bull nose off range.

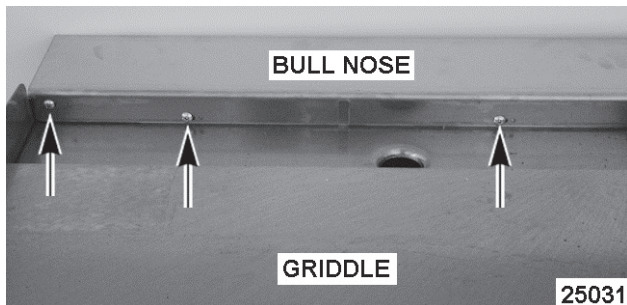

Fig. 6

5. Reverse procedure to install.

CONTROL BRACKET



WARNING Disconnect the electrical power to the machine and follow lockout / tagout procedures.

WARNING Shut off the gas before servicing the unit.

WARNING All gas joints disturbed during servicing must be checked for leaks. Check with a soap and water solution (bubbles). Do not use an open flame.

1. Remove BULL NOSE.
2. Remove CONTROL BRACKET COVER.
3. If installed, remove compression nut on the flexible tubing gas line that supplies gas to the manifold on the adjacent open top burner section.

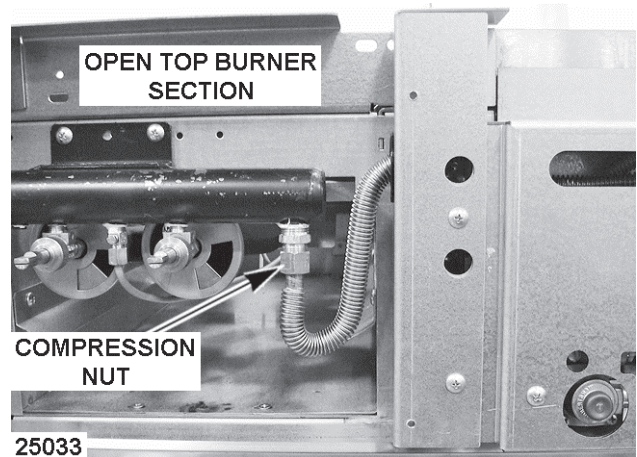

Fig. 7

4. Loosen the recessed screws (4) through the access holes on the two manifold cover brackets (L & R) that secure the control bracket to the oven. The bracket mounting holes are keyed for removal of the control bracket.

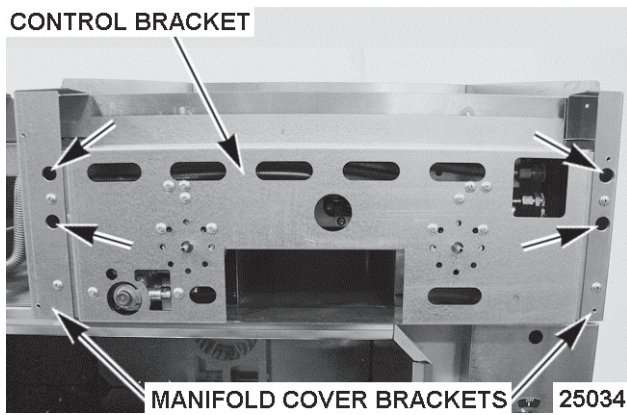

Fig. 8

5. Lift the control bracket up and tilt forward to remove bracket from mounting screws.
6. Partially install the grease drawer leaving enough of the drawer extended to support the control bracket while servicing.

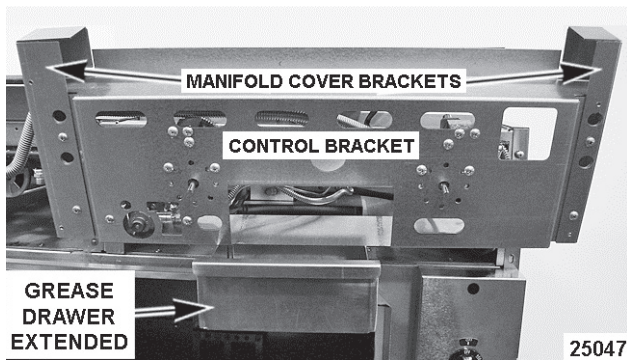

Fig. 9

7. Griddle controls are now accessible for removal.
 - A. If replacing control bracket, remove screws securing griddle controls to bracket.
 - B. Remove manifold cover brackets (L & R) from each end of the control bracket as necessary (2 screws for each bracket).
8. Reverse procedure to install and check for proper operation.

STANDARD OVEN PILOT ASSEMBLY AND THERMOCOUPLE

WARNING Shut off the gas before servicing the unit.

WARNING All gas joints disturbed during servicing must be checked for leaks. Check with a soap and water solution (bubbles). Do not use an open flame.

1. Remove bottom oven rack(s) and rack guides.

2. Remove cavity bottom by lifting up and sliding out.
3. Remove screws securing oven pilot assembly to burner carrier.

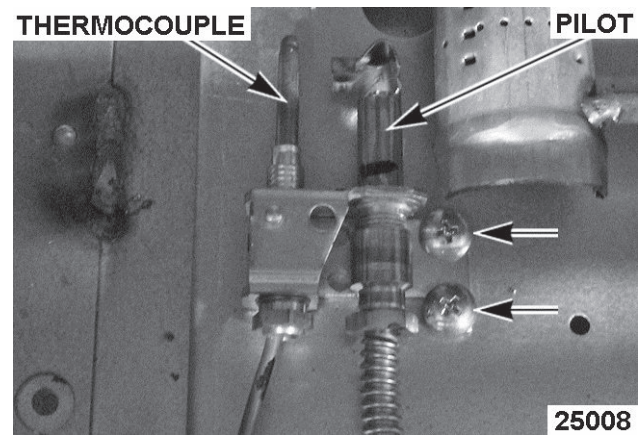

Fig. 10

4. Lower the KICK PANEL (24" & 30" OVENS).
5. Pull oven pilot assembly out through opening in lower oven frame.
6. If replacing thermocouple only, remove thermocouple from oven pilot assembly and gas safety valve. Continue to last step.

NOTICE When installing, do not bend and kink the capillary tube or damage to the component may occur.

7. If replacing oven pilot assembly, remove pilot tubing and thermocouple from oven pilot assembly.
8. Reverse procedure to install and check for proper operation.

STANDARD OVEN BURNER

WARNING Shut off the gas before servicing the unit.

WARNING All gas joints disturbed during servicing must be checked for leaks. Check with a soap and water solution (bubbles). Do not use an open flame.

1. Lower the KICK PANEL (24" & 30" OVENS).
2. Hold the tab on burner carrier with pliers to support it then remove compression nut from burner elbow fitting to disconnect gas supply tubing.
3. Remove screws securing burner carrier to oven frame.

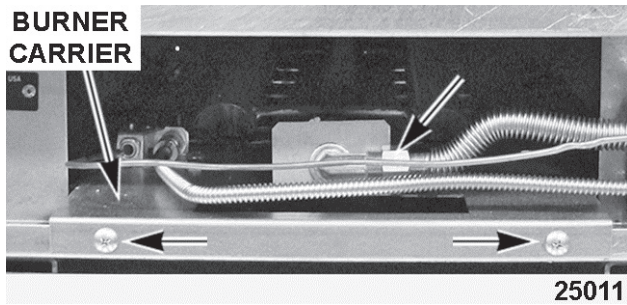

Fig. 11

4. Pull burner carrier out through opening in lower oven frame enough to access the oven pilot assembly.
5. Remove screws securing oven pilot assembly to burner carrier. Move oven pilot assembly away from burner.

NOTICE Do not bend and kink the capillary tube or damage to the control may occur.

6. Pull burner carrier with burner attached out from oven.
7. Remove screws securing burner to the burner carrier.

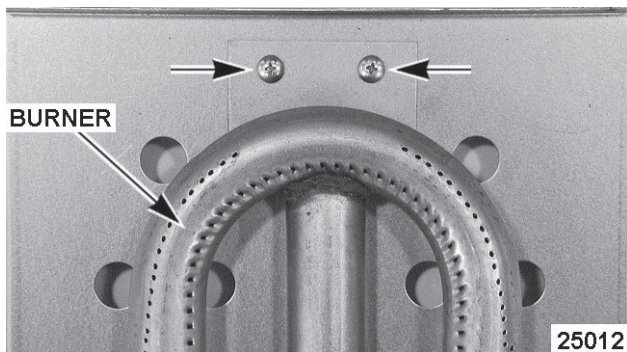

Fig. 12

8. Slide oven burner off the burner nozzle to remove.
9. Reverse procedure to install.
10. Perform BURNER AIR SHUTTER ADJUSTMENT.

STANDARD OVEN THERMOSTAT (24" OVEN)

WARNING Shut off the gas before servicing the unit.

WARNING All gas joints disturbed during servicing must be checked for leaks. Check with a soap and water solution (bubbles). Do not use an open flame.

1. Pull out crumb tray.
2. Remove MANIFOLD COVER.
3. Remove oven thermostat knob.
4. Remove screw securing thermostat cover to oven frame.



Fig. 13

5. Remove compression nut from elbow fitting at the rear of thermostat.
6. Remove screws securing thermostat to mounting flange.

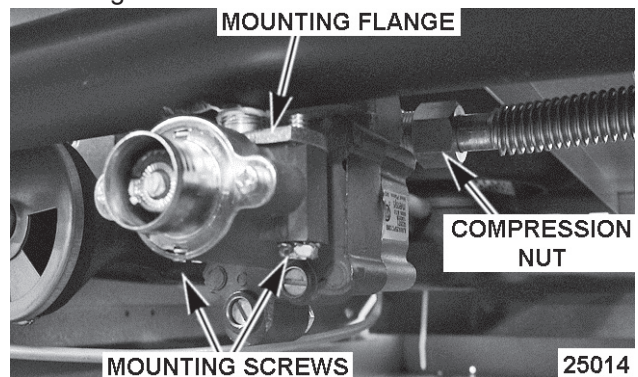

Fig. 14

- A. Inspect mounting flange and gasket. If okay, they may be used during installation. If not okay, remove and install replacement flange.

7. Open oven door and remove oven racks.
8. Remove screws securing capillary tube mounting clips (5) inside the oven cavity.

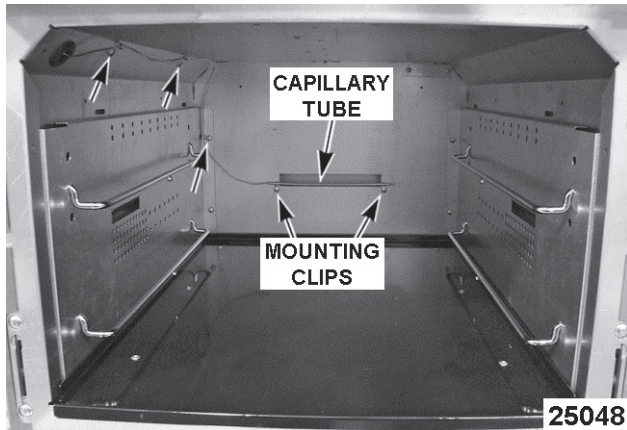

Fig. 15

NOTE: Capillary tube is permanently attached to thermostat-combo valve.

9. Remove all mounting clips from capillary tube and retain for reuse.
10. Pull capillary tube through the hole in oven sidewall and remove thermostat from oven.
 - A. Remove insulation sleeve from capillary tube for installation on replacement thermostat capillary tube.
 - B. Note orientation of compression fitting elbow on valve body and remove for installation on replacement valve body.

⚠ WARNING Clean pipe threads and apply thread sealant that is suitable for use with propane gases.

NOTICE When installing, do not bend and kink the capillary tube or damage to the control may occur.

11. Reverse procedure to install and check for proper operation.

STANDARD OVEN THERMOSTAT (30" OVEN)

⚠ WARNING Shut off the gas before servicing the unit.

⚠ WARNING All gas joints disturbed during servicing must be checked for leaks. Check with a soap and water solution (bubbles). Do not use an open flame.

1. Open oven door and remove oven racks.

2. Remove screws securing capillary tube mounting clips (5) inside the oven cavity.

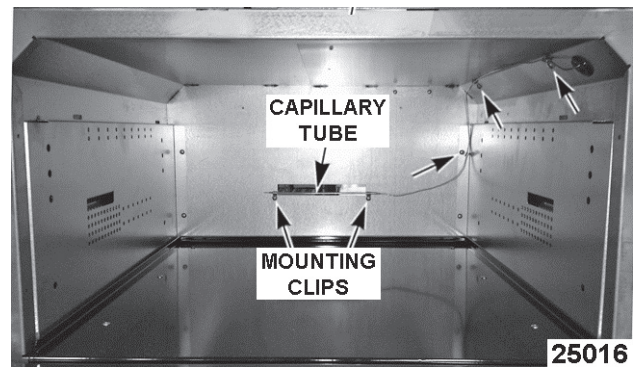

Standard 30" oven

NOTE: Capillary tube is permanently attached to thermostat.

3. Remove all mounting clips from capillary tube and retain for reuse.
4. Remove CONTROL PANEL (30" OVENS).
5. Remove compression nuts from thermostat fittings (front & rear).
6. Remove screws securing thermostat to mounting bracket.

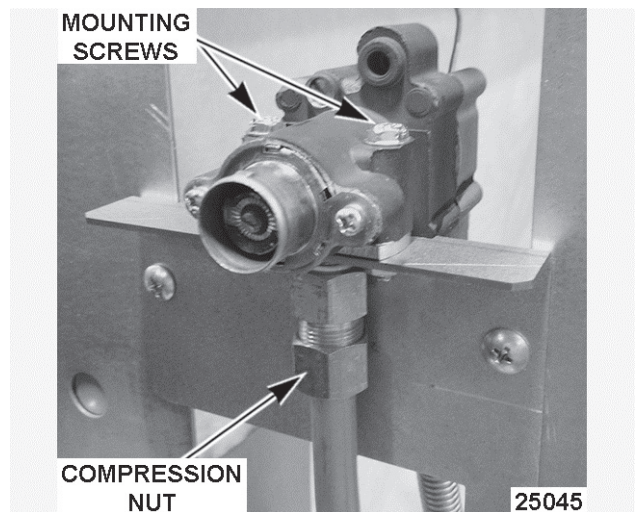

Fig. 17

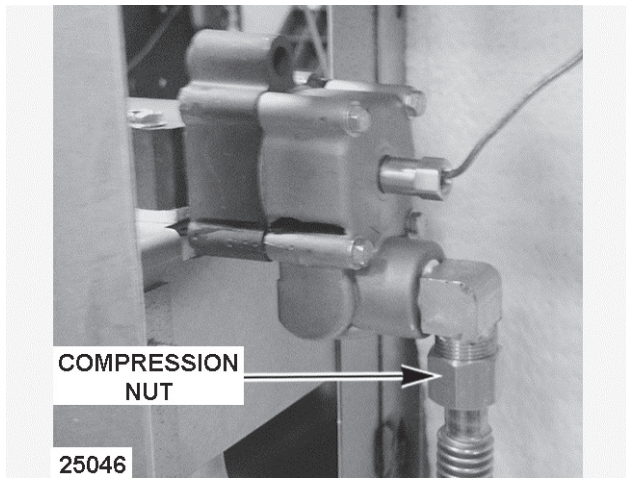

Fig. 18

7. Remove gas line tubing from thermostat.
8. Pull capillary tube through the hole in oven sidewall and remove thermostat from oven.
 - A. Note orientation of compression fittings on thermostat body and remove for installation on replacement valve body.

⚠ WARNING Clean pipe threads and apply thread sealant that is suitable for use with propane gases.

NOTICE When installing, do not bend and kink the capillary tube or damage to the control may occur.

NOTE: When installing thermostat capillary tube, push any insulation back through grommet and remove loose insulation from oven cavity.

9. Reverse procedure to install and check for proper operation.

CONVECTION OVEN PILOT ASSEMBLY AND THERMOCOUPLE



⚠ WARNING Disconnect the electrical power to the machine and follow lockout / tagout procedures.

⚠ WARNING Shut off the gas before servicing the unit.

⚠ WARNING All gas joints disturbed during servicing must be checked for leaks. Check with a soap and water solution (bubbles). Do not use an open flame.

1. Lower the KICK PANEL (24" & 30" OVENS).

2. Remove screws securing burner carrier to oven frame.

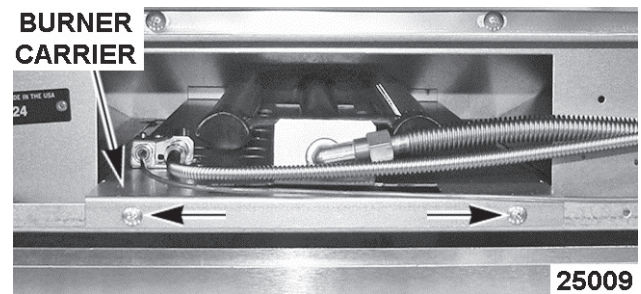

Fig. 19

3. Pull burner carrier out through opening in lower oven frame enough to access the oven pilot assembly.

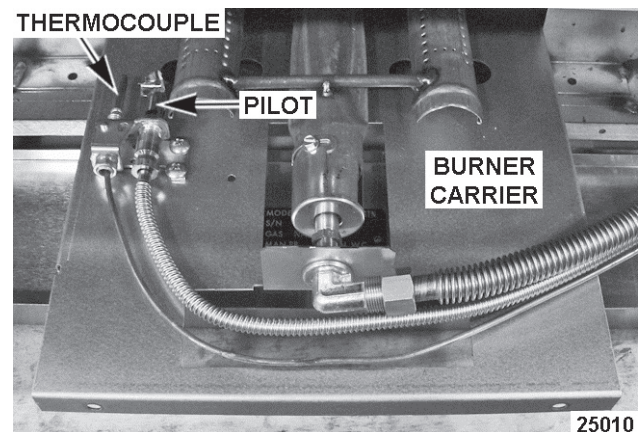

Fig. 20

4. If replacing thermocouple only, remove thermocouple from oven pilot assembly.

NOTICE When installing, do not bend and kink the capillary tube or damage to the component may occur.

- A. Remove CONTROL PANEL (30" OVENS).
 - B. Remove thermocouple from gas safety valve and remove thermocouple from oven. Continue to last step.
5. If replacing oven pilot assembly, remove pilot tubing and thermocouple from oven pilot assembly.
 6. Remove screws securing oven pilot assembly to burner carrier.
 7. Reverse procedure to install and check for proper operation.

CONVECTION OVEN BURNER



WARNING Disconnect the electrical power to the machine and follow lockout / tagout procedures.

WARNING Shut off the gas before servicing the unit.

WARNING All gas joints disturbed during servicing must be checked for leaks. Check with a soap and water solution (bubbles). Do not use an open flame.

1. Lower the KICK PANEL (24" & 30" OVENS).
2. Remove screws securing burner carrier to oven frame.

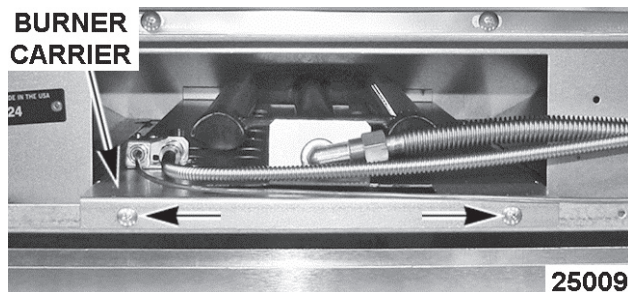

Fig. 21

3. Pull burner carrier out through opening in lower oven frame enough to access the oven pilot assembly and burner elbow fitting.
4. Hold the tab on burner carrier with pliers to support then remove compression nut from burner elbow fitting.
5. Remove screws securing oven pilot assembly to burner carrier. Move pilot assembly away from burner.

NOTICE Do not bend and kink the capillary tube or damage to the control may occur.

6. Pull burner carrier with burner attached out from oven.
7. Remove screws securing burner to the burner carrier.

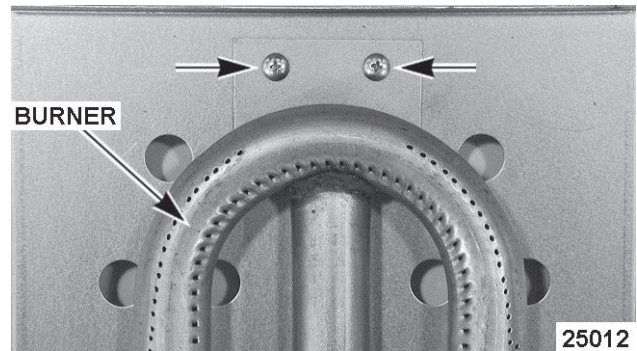

Fig. 22

8. Slide oven burner off the burner nozzle to remove.
9. Reverse procedure to install.
10. Perform BURNER AIR SHUTTER ADJUSTMENT.

CONVECTION OVEN THERMOSTAT-COMBO VALVE



WARNING Disconnect the electrical power to the machine and follow lockout / tagout procedures.

WARNING Shut off the gas before servicing the unit.

WARNING All gas joints disturbed during servicing must be checked for leaks. Check with a soap and water solution (bubbles). Do not use an open flame.

1. Remove CONTROL PANEL (30" OVENS).
2. Remove compression nuts from thermostat-combo valve fittings.
3. Remove screws securing thermostat-combo valve to mounting bracket.

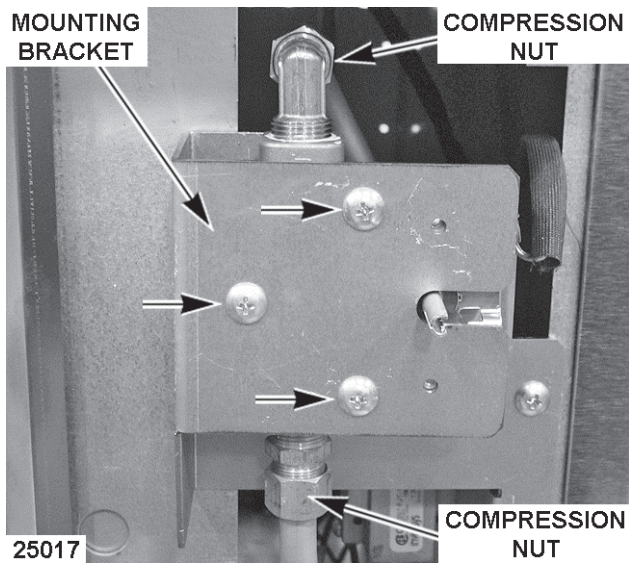

Fig. 23

4. Remove thermostat-combo valve from gas line tubing.
5. Remove oven racks.
6. Open oven door and remove screws securing capillary tube mounting clips (4) at the top of oven cavity.

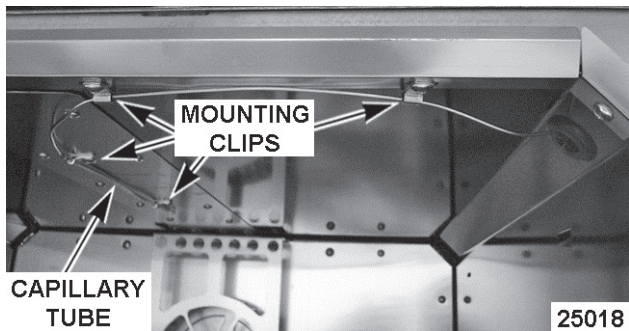

Fig. 24

NOTE: Capillary tube is permanently attached to thermostat-combo valve.

7. Remove all mounting clips from capillary tube and retain for reuse.
8. Pull capillary tube through the hole in oven sidewall and remove thermostat-combo valve from oven.
 - A. Remove insulation sleeve from capillary tube for installation on replacement thermostat capillary tube.
 - B. Note orientation of compression fittings on valve body and remove for installation on replacement valve body.

WARNING Clean pipe threads and apply thread sealant that is suitable for use with propane gases.

NOTICE When installing, do not bend and kink the capillary tube or damage to the control may occur.

NOTE: When installing thermostat capillary tube, push any insulation back through grommet and remove loose insulation from oven cavity.

9. Reverse procedure to install and check for proper operation.

CONVECTION OVEN BLOWER AND MOTOR



WARNING Disconnect the electrical power to the machine and follow lockout / tagout procedures.

1. Remove cover from electrical junction box at the rear of range.
2. Disconnect motor wiring at junction box.
3. Loosen screw securing armored cable to junction box.
4. Remove oven racks and rack guides from oven.
5. Place cardboard over the oven cavity bottom to protect it during motor removal.
6. Remove screws securing motor mount panel to the oven. Pull the assembly out from the oven.

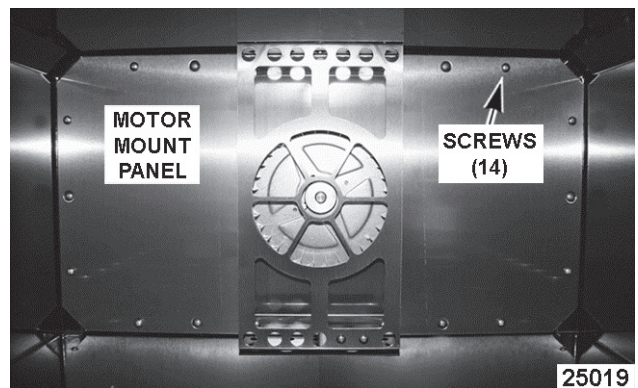

Fig. 25

7. Remove screws (4) securing blower cover to motor mount panel.

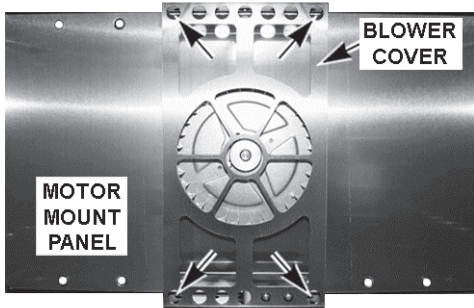

Fig. 26

8. Loosen bolts (2) securing blower to motor shaft then remove blower.
9. If replacing blower only, proceed to last step. If replacing motor, continue with procedure.
10. Remove mounting nuts and spacers securing motor mounting brackets (2) to motor mount panel.

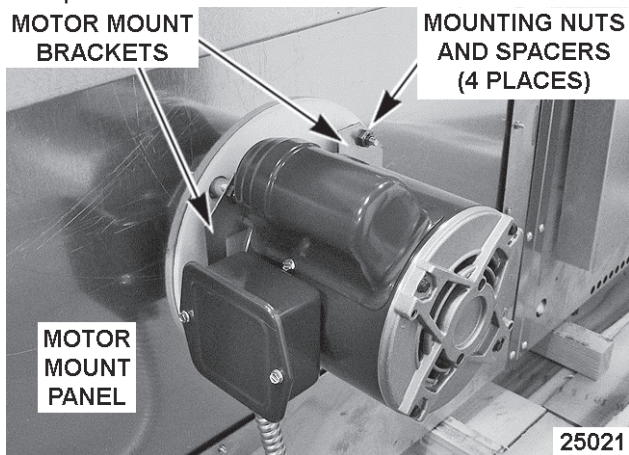

Fig. 27

- A. Remove motor mounting brackets from motor for reuse.
 - B. Remove cover from motor junction box, disconnect wires and remove armored cable from motor junction box.
 - C. Inspect the motor insulation located between the motor mounting brackets and the motor mount panel. Replace if damaged.
11. Install motor mounting brackets and armored cable onto replacement motor.
 12. Reverse procedure to install and check for proper operation.

BURNER ORIFICE HOOD (STANDARD AND CONVECTION Ovens)

1. Access burner for the type of oven being serviced as outlined under STANDARD OVEN BURNER or CONVECTION OVEN BURNER.
2. Remove the orifice hood from fitting.
3. Perform BURNER NOZZLE CHECK.
4. Reverse procedure to install.
5. Check for proper operation.

GAS SAFETY VALVE (STANDARD AND CONVECTION Ovens)



⚠ WARNING Disconnect the electrical power to the machine and follow lockout / tagout procedures.

⚠ WARNING Shut off the gas before servicing the unit.

⚠ WARNING All gas joints disturbed during servicing must be checked for leaks. Check with a soap and water solution (bubbles). Do not use an open flame.

1. Remove CONTROL PANEL (30" OVENS) on standard and convection ovens or lower the KICK PANEL (24" & 30" OVENS) on standard 24" ovens.
2. Remove pilot tubing and thermocouple from gas safety valve.
3. Remove inlet and outlet gas lines from gas safety valve.

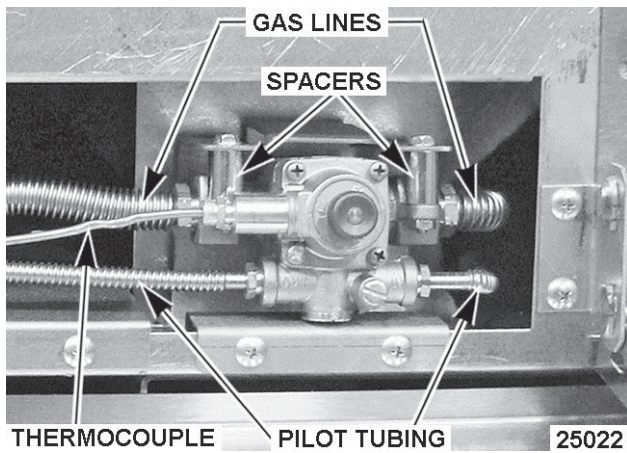

Gas Safety Valve on Standard 24" Oven

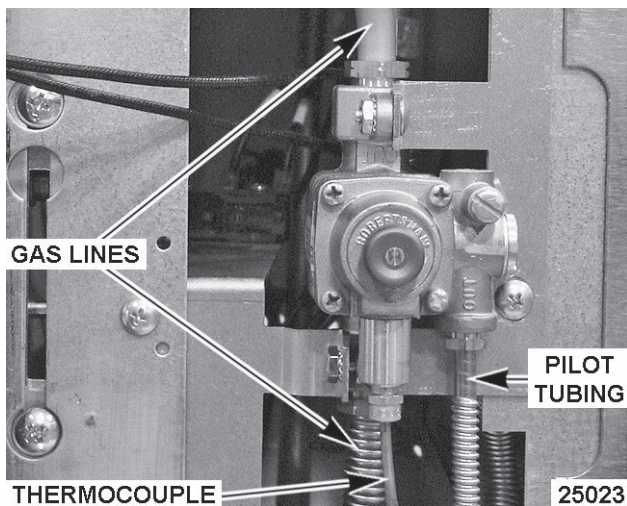

Gas Safety Valve on 30" Convection Oven

NOTE: Safety valve replacement is identical on 30 inch wide standard ovens.

4. Remove screws securing gas safety valve to mounting bracket and remove the valve. On 24" standard ovens, spacers are installed between the valve and mounting bracket. Retain spacers for reuse. Spacer locations shown in picture [25022 "Gas Safety Valve on Standard 24" Oven"](#).
5. Remove compression fittings and tubing from gas safety valve for installation on replacement valve.

⚠ WARNING Clean pipe threads and apply thread sealant that is suitable for use with propane gases.

6. Reverse procedure to install and check for proper operation.

TOP BURNER PILOT VALVE



⚠ WARNING Disconnect the electrical power to the machine and follow lockout / tagout procedures.

⚠ WARNING Shut off the gas before servicing the unit.

⚠ WARNING All gas joints disturbed during servicing must be checked for leaks. Check with a soap and water solution (bubbles). Do not use an open flame.

1. On the module section being serviced, loosen set screw on top burner knobs and remove knobs from manual valve.
2. Remove MANIFOLD COVER.
3. Remove compression nut securing pilot tube to pilot valve.
4. Remove pilot valve from the manifold.

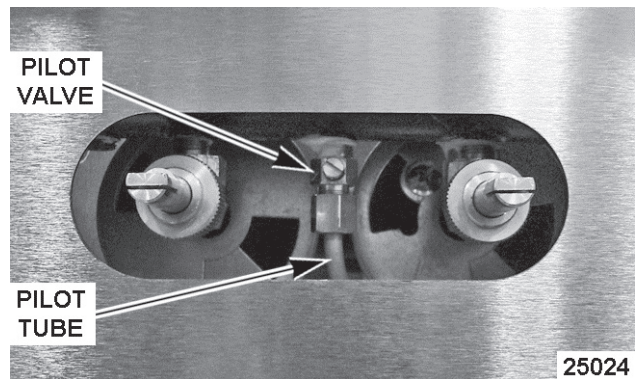

Fig. 30

5. Reverse procedure to install.

⚠ WARNING Clean pipe threads and apply thread sealant that is suitable for use with propane gases.

NOTICE Do not over tighten pilot valve or damage to the threads may occur.

6. Check PILOT FLAME HEIGHT under Open Top Burner Adjustment.

TOP BURNER ASSEMBLY



⚠ WARNING Disconnect the electrical power to the machine and follow lockout / tagout procedures.

⚠ WARNING Shut off the gas before servicing the unit.

⚠ WARNING All gas joints disturbed during servicing must be checked for leaks. Check with a soap and water solution (bubbles). Do not use an open flame.

1. Remove top burner grates (front and rear) from the module section being serviced.
2. Remove pilot from mounting clip on the top burner assembly. Move pilot away from burner assembly.

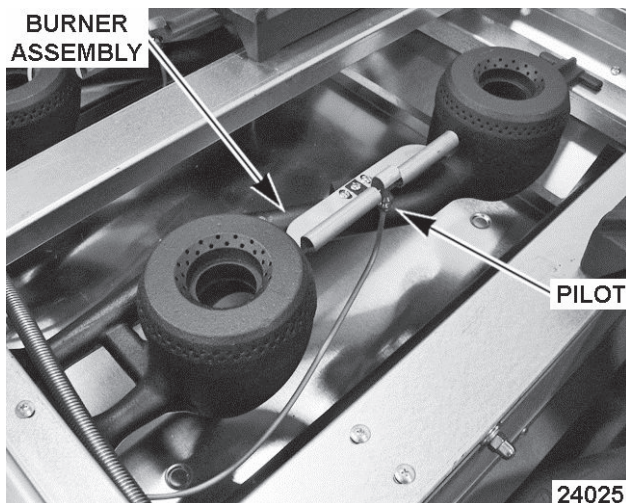

Fig. 31

3. Lift burner heads off the top burner assembly.
4. Lift the top burner assembly at the rear and pull away from manual valves.
 - A. Remove pilot mounting clip and flash tube from the top burner assembly for reuse on replacement burner assembly.
5. Reverse procedure to install.

NOTE: When installing, ensure that each end of the flash tube is aligned with the ignition ports on the burner “venturi” casting for proper burner ignition.

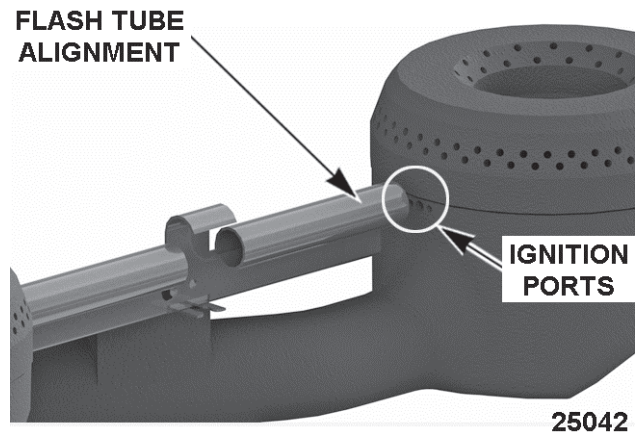

Fig. 32

6. Check for proper operation.
7. Verify BURNER AIR SHUTTER ADJUSTMENT.

TOP BURNER CONTROL VALVE



⚠ WARNING Disconnect the electrical power to the machine and follow lockout / tagout procedures.

⚠ WARNING Shut off the gas before servicing the unit.

⚠ WARNING All gas joints disturbed during servicing must be checked for leaks. Check with a soap and water solution (bubbles). Do not use an open flame.

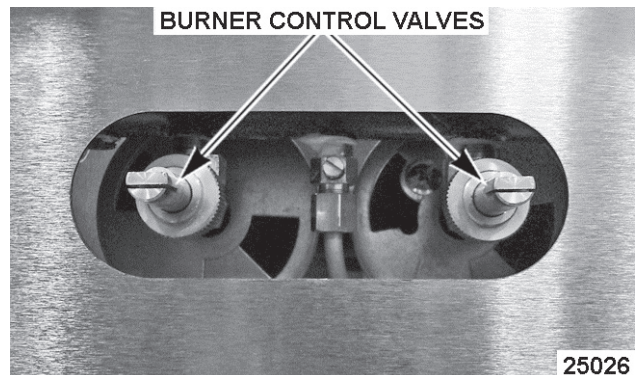

Fig. 33

1. Remove MANIFOLD COVER.
2. Remove TOP BURNER ASSEMBLY.
3. Remove TOP BURNER PILOT VALVE.
4. Remove top burner control valve from the manifold.

5. Inspect the top control valve for wear and damage, replace as necessary.
6. Reverse procedure to install.

⚠ WARNING Clean pipe threads and apply thread sealant that is suitable for use with propane gases.

NOTE: When installing, ensure top burner control valve is aligned and centered in the burner assembly opening. The valve must be perpendicular to the manifold.

7. Check for proper operation.

TOP BURNER ORIFICE HOOD

1. Access top burner orifice hood as outlined under TOP BURNER ASSEMBLY.
2. Remove the orifice hood from top burner control valve.
3. Reverse procedure to install.
4. Check for proper operation.

OVEN DOOR

Removal

1. Remove CONTROL PANEL (30" OVENS).

NOTE: Removal of control panel is to provide additional space on the right side of door to ease door removal and installation.

2. Lower KICK PANEL (24" & 30" OVENS).
3. Fully open the oven door.
4. Insert a 1/4"-20 x 1" bolt (see TOOLS) into each door hinge slot at the top of the spring loaded hinge.

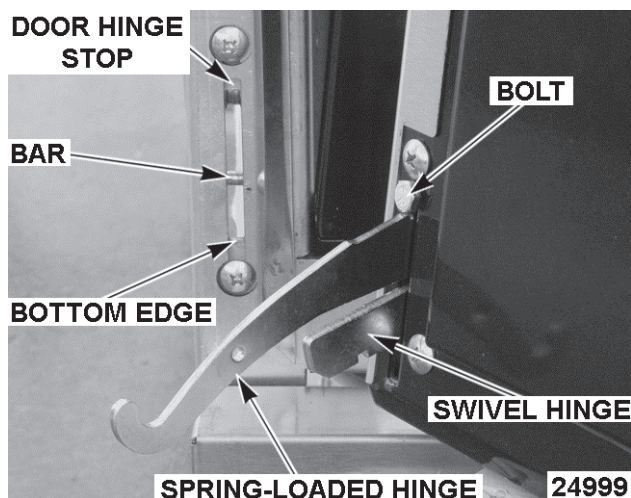

Fig. 34

5. Close door leaving enough space to clear the oven gas manifold cover during removal. As the door approaches this position, you should notice a decrease in the spring tension on the door.
6. Remove door as follows:
 - A. Hold door at bottom corners then lift the door up and out to disengage the hinges.
 - B. The notch on swivel hinge must release from bottom edge of the door hinge stop to remove door. As needed, lift up on the swivel hinges using forefinger to aid in releasing.
 - C. The spring-loaded hinge must release from the roller inside the slot on door hinge stop to remove door.
7. If replacing door or door spring hinge, position the door face down. Press down on hinge enough to relieve spring force then remove bolt from door hinge slot.

Installation

1. Compress each spring-loaded hinge enough to insert the bolt into the slot at top of hinge.
2. Hold door at bottom corners while facing the oven cavity. Place knee on the front of door to help balance it as necessary during installation.
 - A. Using index fingers, lift swivel hinges until they touch the spring-loaded hinges and hold in place.
 - B. Tilt the top of door toward the oven so that the swivel hinge is at a slightly downward angle to pass between the bar and bottom edge of door hinge stop.
 - C. Insert hinges into the slots making sure that the spring-loaded hinges go above the bar to catch on the roller and the swivel hinges go underneath the bar to catch on the bottom edge of door hinge slot.
 - D. Lower the door and position it as necessary to engage the swivel hinge slots with the bottom edge of both door hinge slots.



Fig. 35

3. Fully open door to check operation. If bottom edge of door rubs the front edge of cavity bottom then the swivel hinge is not engaged as described.
 - A. To seat the swivel hinge, open door approximately 30° and pull in the same direction on the door handle. The hinge should drop into place.
4. Open door and check operation. If okay, remove bolts and close door. If not okay, remove door and repeat installation procedure.
5. On convection ovens, verify door switch is operating properly.
6. Reinstall oven control panel.
7. Raise kick panel.

GAS PRESSURE REGULATOR



⚠ WARNING Disconnect the electrical power to the machine and follow lockout / tagout procedures.

⚠ WARNING Shut off the gas before servicing the unit.

⚠ WARNING All gas joints disturbed during servicing must be checked for leaks. Check with a soap and water solution (bubbles). Do not use an open flame.

⚠ WARNING Clean pipe threads and apply thread sealant that is suitable for use with propane gases.

1. Thread regulator onto pipe hand tight with arrow pointing in direction of gas flow to the range.

REGULATOR ADJUSTMENT (BELOW CLOSING NUT)

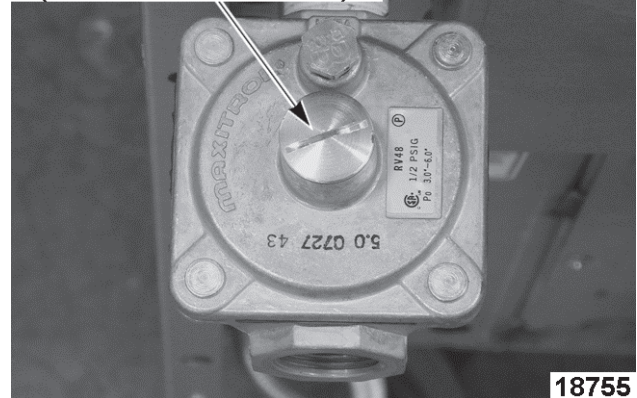

Fig. 36

2. Tighten regulator securely in horizontal position with the regulator adjustment upward as described on regulator.

NOTE: Regulator will not function properly without adjustment screw pointing upward.

3. Connect supply gas line to gas pressure regulator inlet.
4. Adjust regulator as outlined in REGULATOR ADJUSTMENT.

CONVECTION OVEN DOOR SWITCH



⚠ WARNING Disconnect the electrical power to the machine and follow lockout / tagout procedures.

NOTE: Door switch is installed on Convection Ovens only.

1. Remove CONTROL PANEL (30" OVENS).
2. Remove single mounting nut securing door switch bracket to safety valve mounting bracket.
3. Remove screws securing door switch bracket to oven frame and remove bracket from control area.

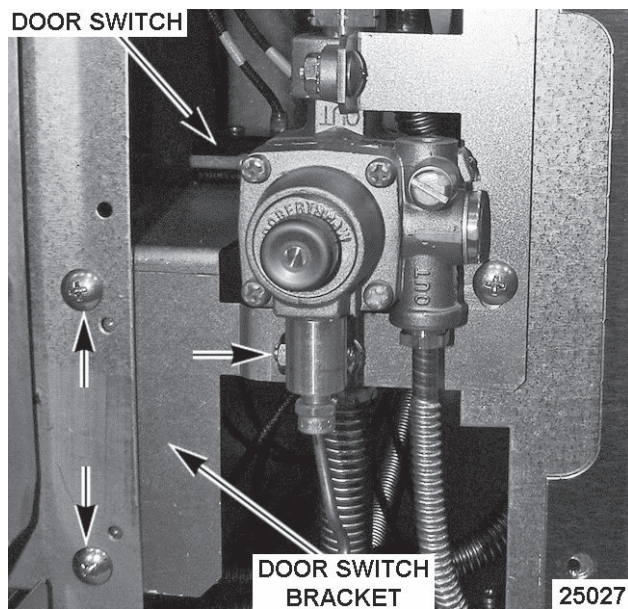

Fig. 37

4. Open door to unoperate the switch.
5. Note lead wire locations and disconnect from door switch.
6. Remove screws and mounting nuts securing door switch to door switch bracket.

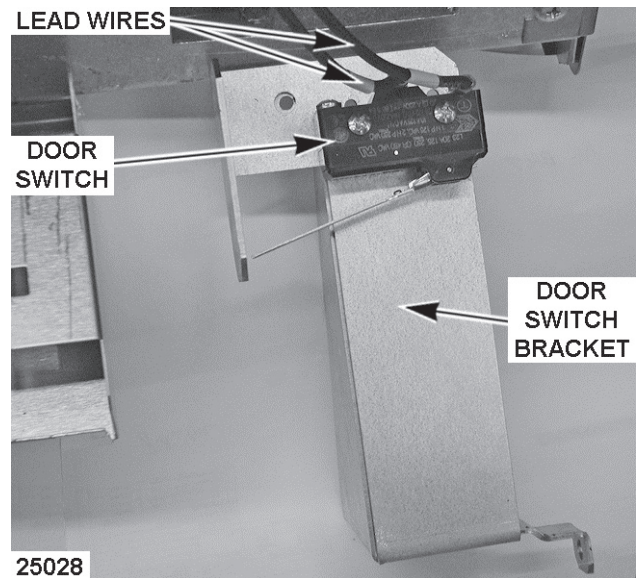

Fig. 38

7. Reverse procedure to install and check door switch for proper operation.

CONVECTION OVEN SOLENOID



⚠ WARNING Disconnect the electrical power to the machine and follow lockout / tagout procedures.

⚠ WARNING Shut off the gas before servicing the unit.

⚠ WARNING All gas joints disturbed during servicing must be checked for leaks. Check with a soap and water solution (bubbles). Do not use an open flame.

1. Remove door switch bracket as outlined under CONVECTION OVEN DOOR SWITCH. Allow bracket to rest at the bottom of control area.
2. Remove screws securing the mounting bracket that holds the safety valve, oven thermostat and the oven solenoid to the oven frame.

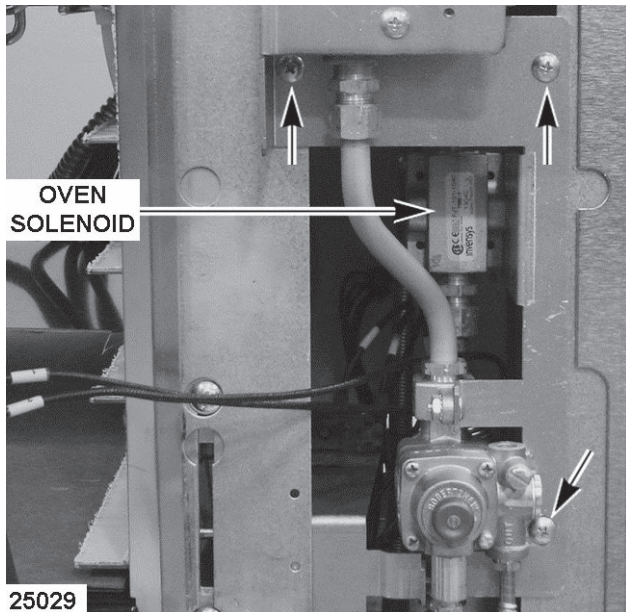

Fig. 39

3. Remove compression nuts on the inlet and outlet of solenoid.
4. Remove screws and mounting nuts securing solenoid to bracket.
5. Disconnect lead wires from solenoid.

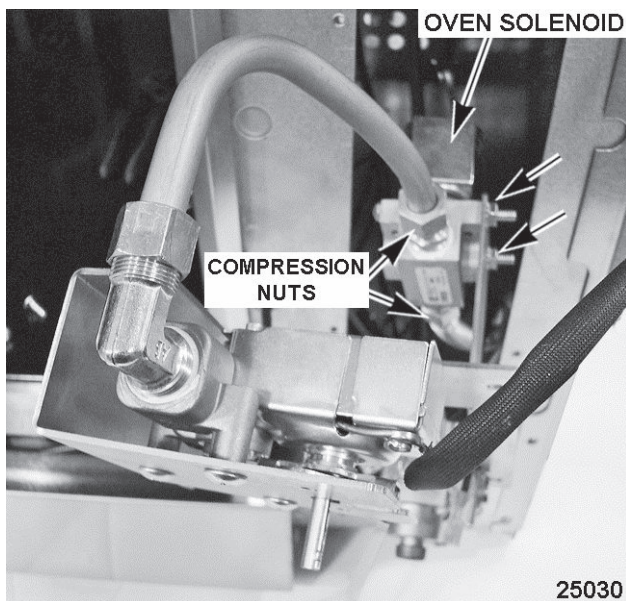

Fig. 40

6. Remove fittings from solenoid for reuse on replacement valve.

⚠ WARNING Clean pipe threads and apply thread sealant that is suitable for use with propane gases.

7. Reverse procedure to install and check for proper operation.

GRIDDLE THERMOSTAT-COMBO VALVE



⚠ WARNING Disconnect the electrical power to the machine and follow lockout / tagout procedures.

⚠ WARNING Shut off the gas before servicing the unit.

⚠ WARNING All gas joints disturbed during servicing must be checked for leaks. Check with a soap and water solution (bubbles). Do not use an open flame.

1. Remove BULL NOSE.
2. Raise griddle plate from the front and support using 4x4 blocks.
3. Pull thermostat bulb out of the holder for the thermostat-combo valve being replaced.

NOTE: Capillary tube is permanently attached to thermostat-combo valve.

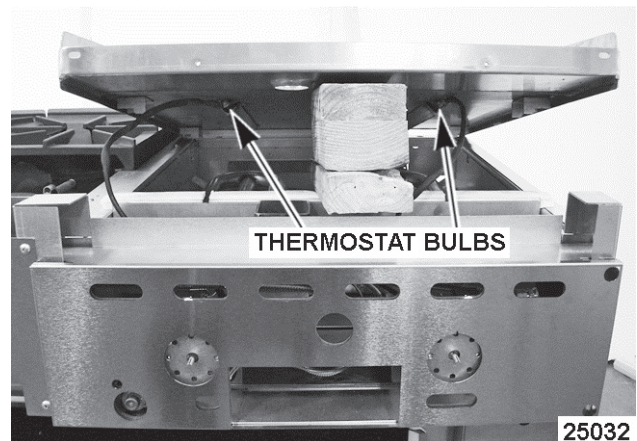

Fig. 41

4. Remove CONTROL BRACKET COVER.
5. If installed, remove compression nut on the flexible tubing gas line that supplies gas to the manifold on the adjacent open top burner section.

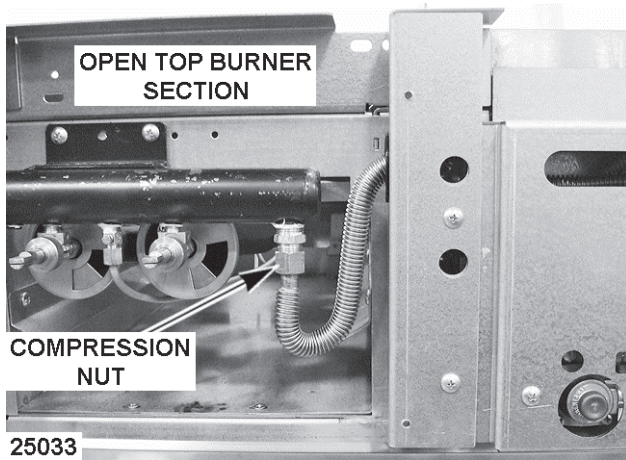

Fig. 42

6. Loosen the recessed screws (4) through the access holes on the two manifold cover brackets (L & R) that secure the control bracket to the oven. The bracket mounting holes are keyed for removal of the control bracket.

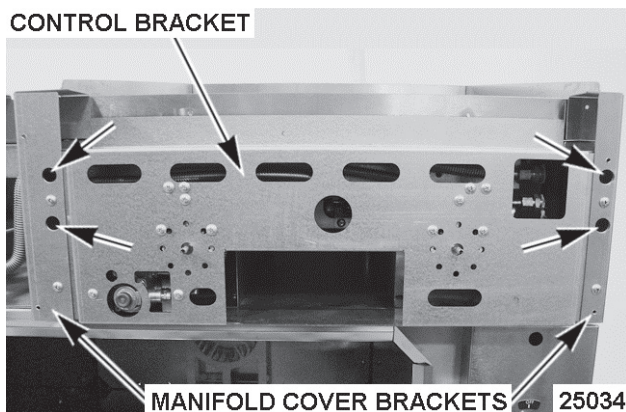

Fig. 43

7. Lift up control bracket and tilt forward to access griddle thermostat-combo valves.
8. Partially install the grease drawer leaving enough of the drawer extended to support the control bracket while servicing.

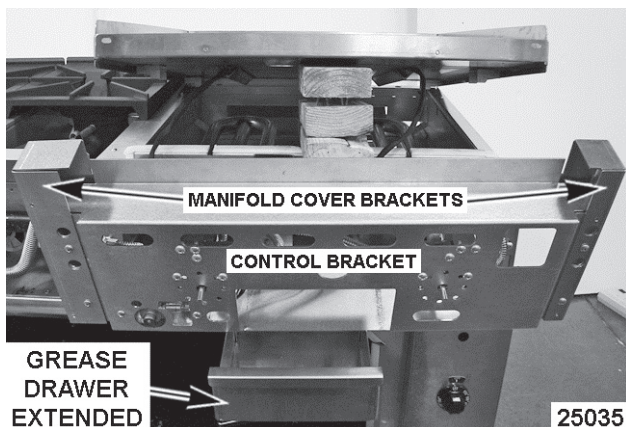

Fig. 44

9. Remove compression nuts from thermostat-combo valve fittings for the thermostat being replaced.

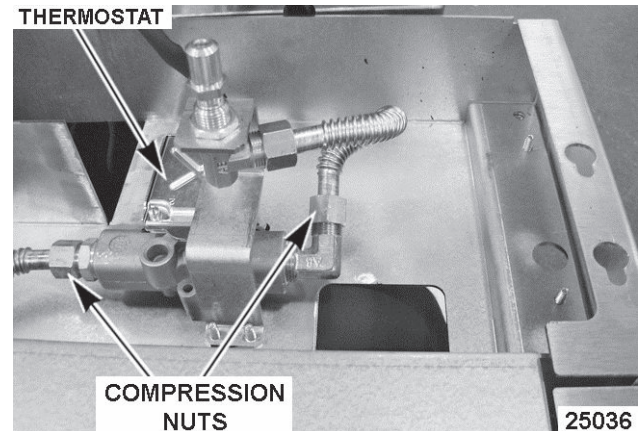

Fig. 45

10. Remove screws (3) securing thermostat-combo valve to the control bracket and remove the thermostat-combo valve.

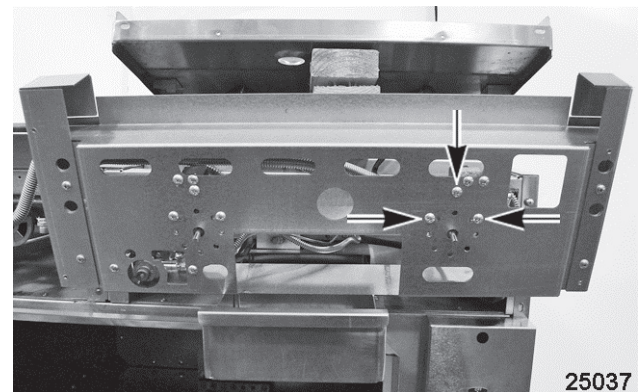

Fig. 46

- A. Note orientation of compression fittings on the thermostat-combo valve and remove for installation on replacement valve.
- B. Remove insulation sleeve from capillary tube for installation on replacement thermostat capillary tube.

WARNING Clean pipe threads and apply thread sealant that is suitable for use with propane gases.

NOTICE When installing, do not bend and kink the capillary tubes or damage to the controls may occur. Ensure capillary tubes are routed properly through mounting slots before lowering the griddle or damage to the controls may occur.

NOTE: When installing, ensure orifice hood is aligned and centered in the burner assembly opening. The griddle orifice bracket must be perpendicular to the manifold.

- Reverse procedure to install and check for proper operation.

GRIDDLE GAS SAFETY VALVE



WARNING Disconnect the electrical power to the machine and follow lockout / tagout procedures.

WARNING Shut off the gas before servicing the unit.

WARNING All gas joints disturbed during servicing must be checked for leaks. Check with a soap and water solution (bubbles). Do not use an open flame.

- Remove CONTROL BRACKET.
- Remove pilot tubing and thermocouple from gas safety valve.
- Remove compression nuts from gas safety valve fittings.

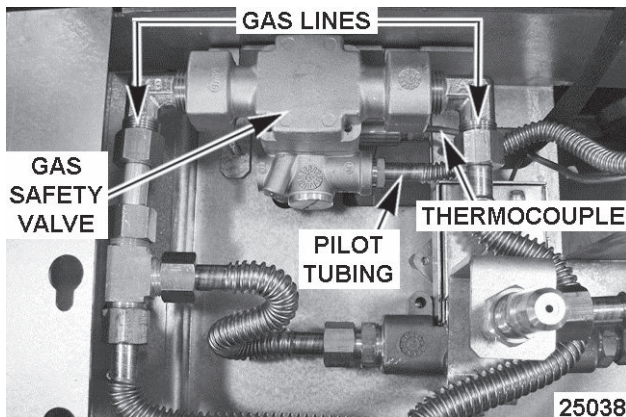

Fig. 47

- Remove screws (2) securing gas safety valve to the control bracket and remove the valve.
 - Note orientation of compression fittings on the valve and remove for installation on replacement valve.

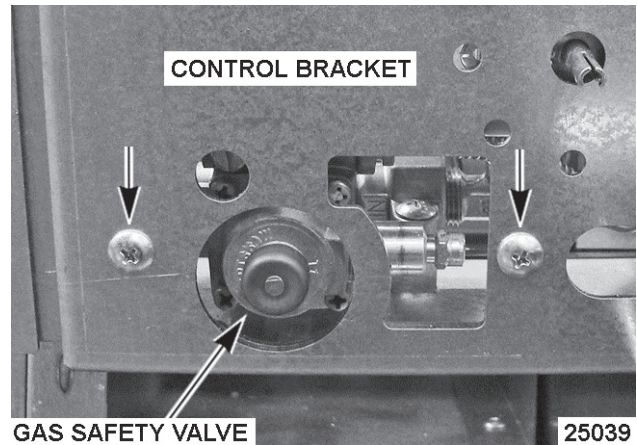

Fig. 48

NOTICE When installing, do not bend and kink the capillary tube or damage to the control may occur.

NOTICE Clean pipe threads and apply pipe joint compound. Any pipe joint compound used must be resistant to the reaction of propane gases.

NOTE: When installing, ensure orifice hood is aligned and centered in the burner assembly opening.

- Reverse procedure to install and check for proper operation.

GRIDDLE PILOT ASSEMBLY AND THERMOCOUPLE



WARNING Disconnect the electrical power to the machine and follow lockout / tagout procedures.

WARNING Shut off the gas before servicing the unit.

WARNING All gas joints disturbed during servicing must be checked for leaks. Check with a soap and water solution (bubbles). Do not use an open flame.

- Remove CONTROL BRACKET.
- Remove screws (2) securing pilot assembly mounting bracket to griddle burner box.
 - If replacing thermocouple only, remove thermocouple from pilot assembly and gas safety valve. Continue to last step.
- If replacing pilot assembly, remove pilot tubing and thermocouple from pilot assembly.

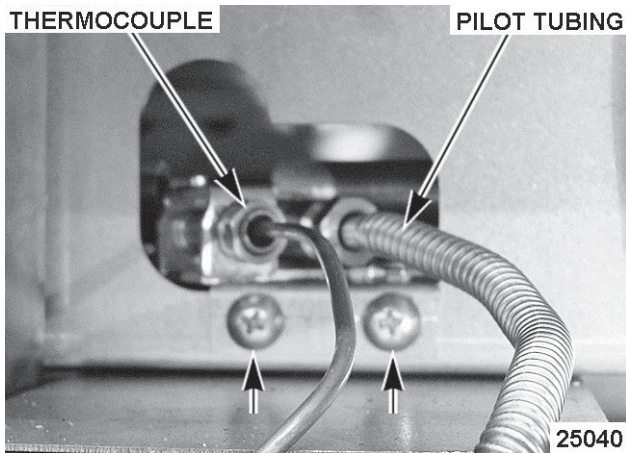

Fig. 49

4. Remove screws (2) securing pilot assembly to mounting bracket.
5. Reverse procedure to install and check for proper operation.

NOTICE When installing, do not bend and kink the capillary tube or damage to the control may occur.

NOTE: When installing, ensure orifice hood is aligned and centered in the burner assembly opening.

GRIDDLE BURNER ORIFICE HOOD

⚠ WARNING Shut off the gas before servicing the unit.

⚠ WARNING All gas joints disturbed during servicing must be checked for leaks. Check with a soap and water solution (bubbles). Do not use an open flame.

1. Remove CONTROL BRACKET.
2. Remove the orifice hood from fitting.

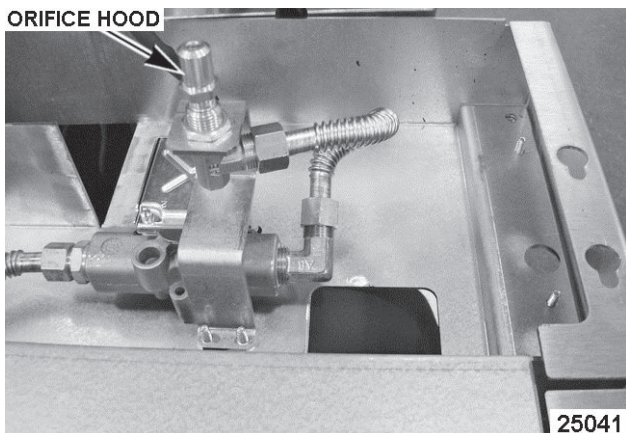

Fig. 50

3. Reverse procedure to install and check for proper operation.

SERVICE PROCEDURES AND ADJUSTMENTS

PILOT FLAME HEIGHT

Oven Pilot Adjustment

1. Remove CONTROL PANEL (30" OVENS).
2. Lower the KICK PANEL (24" & 30" OVENS) to access gas safety valve on 24" standard ovens and to view pilot flame height on all ovens.
3. Remove pilot adjustment cover screw from gas safety valve.

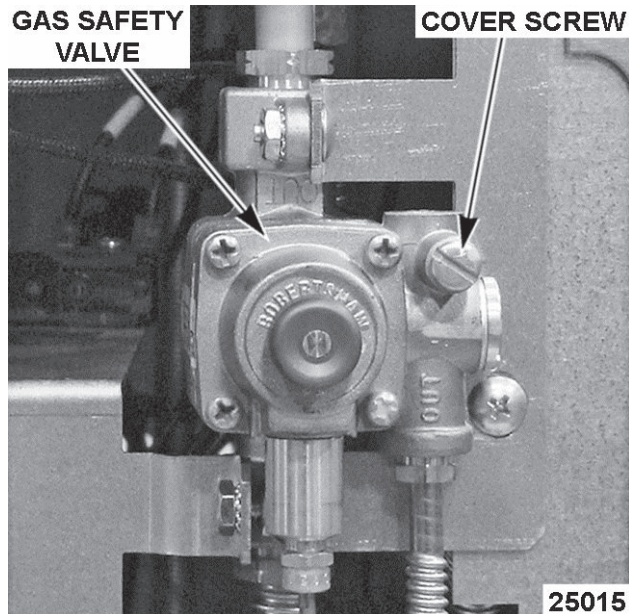

Gas Safety Valve on 30" Ovens Shown
(Convection & Standard)

4. Rotate pilot adjustment screw *clockwise* to decrease and *counterclockwise* to increase pilot flame height.
5. Pilot flame is in adjustment when it is approximately $\frac{1}{2}$ " tall and flame surrounds one third of the thermocouple down from the tip of the hot junction end.
6. Reverse procedure to install and check for proper operation.

NOTE: After adjustment, ensure cover screw is re-installed.

Open Top Pilot Adjustment

To adjust the pilot flame height of the top burners, locate the pilot adjustment screws found on the front manifold pipe between the burner control knobs. It is not necessary to remove the gas manifold cover as adjustment access holes have been provided in the

panel. You may need to remove a knob depending on the orientation of the pilot adjustment screw.

1. Locate the pilot adjustment screw located behind the adjustment access hole in the panel.

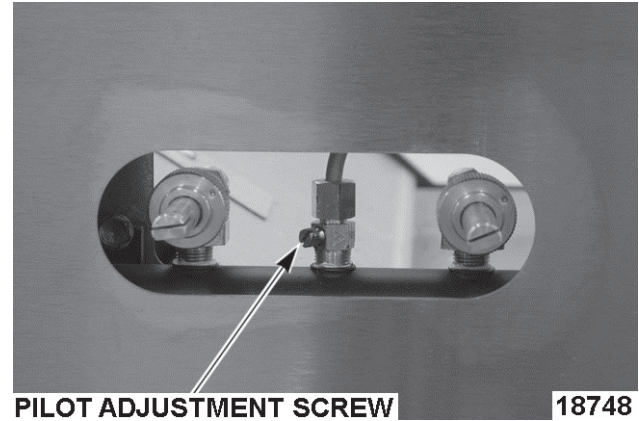

Fig. 52

2. Rotate the screw clockwise to decrease and counterclockwise to increase flame height.
3. Pilot is in adjustment when it will stay on continually and lights the burners without delayed ignition.

BURNER AIR SHUTTER ADJUSTMENT

The efficiency of the burner depends on a delicate balance between the air supply and volume of gas. Whenever this balance is disturbed, poor operating characteristics and excessive gas consumption may occur. An air shutter on the front of the burner controls the gas mixer balance. A yellow streaming flame on the burner is an indication of insufficient primary air.

To correct this condition, loosen the shutter screw and rotate the air shutter open until the flame begins to lift from the burner, then close the shutter slightly and tighten the shutter screw. A proper flame should be blue in color, well-defined and seated on the burner port. A white-blue flame is a result of excessive primary air.

NOTE: The factory default air shutter positions are half open natural; full open propane.

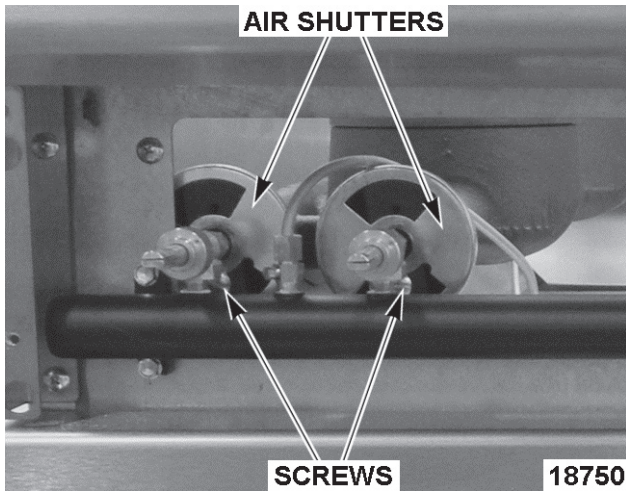

Top Burner Air Shutters

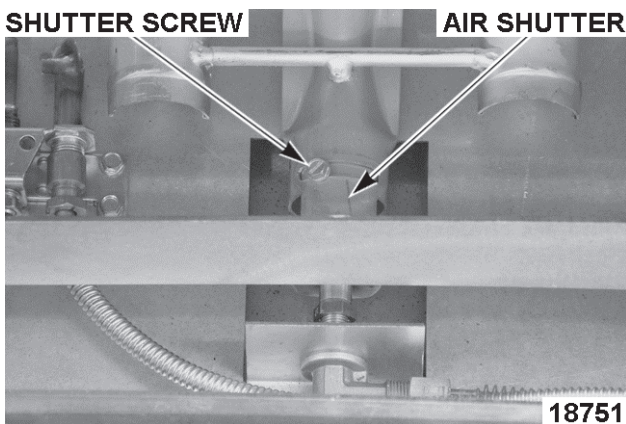

Oven Burner Air Shutter Shown

REGULATOR ADJUSTMENT

NOTE: Regulators come preset, but should be checked anytime one is installed. Before adjusting regulator, check incoming gas line pressure. Incoming pressure must be 6-14" W.C. for natural gas and 11-14" W.C. for propane gas. If incoming pressure is not correct, have the gas source checked and adjusted as necessary. Make sure the regulator is mounted in the horizontal position with the arrow pointing in the direction of gas flow. See unit data plate, riveted inside the kick panel, for manifold pressure setting information. Clean vent cap before adjusting.

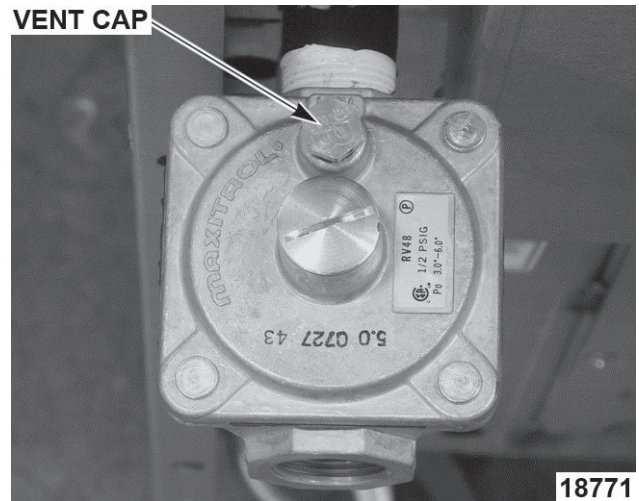

Fig. 55

1. Connect manometer to either of the pressure taps provided on the range gas piping between the burner control valve sets.

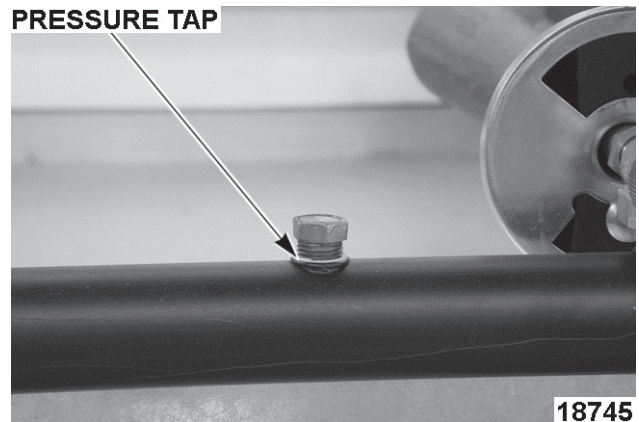
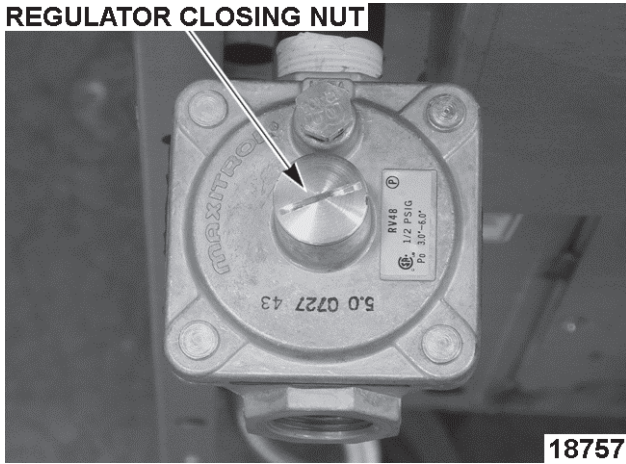

Fig. 56

2. Check manometer reading. The reading should be 5" W.C. for natural gas and 10" W.C. for propane gas. Tolerance is ± 0.3 " W.C.
3. If manifold pressure is not correct, adjust the regulator. Remove the regulator closing nut.

REGULATOR CLOSING NUT



18757

Fig. 57

4. Insert a flat edge screwdriver through the top of the regulator. While watching the manometer, turn the adjusting screw clockwise to increase pressure and counterclockwise to decrease pressure.
5. Install the regulator closing nut.
6. Apply thread sealant to pressure tap plug and reinstall. Thread sealant must be insoluble in propane and natural gas.

BURNER NOZZLE CHECK

The burner nozzle is mounted between the oven gas supply tubing/mounting bracket and the u-burner assembly. If burner operation seems poor and other systems have been checked, access the burner for the range section being serviced and remove the burner nozzle.

- Check for blockage or damage.
- Verify gas orifice hood is correct for the altitude. See Parts Catalog for Orifice Hood Chart.

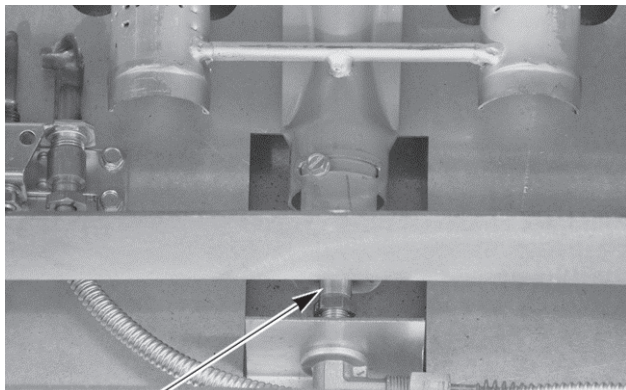

18749

OVEN BURNER NOZZLE SHOWN

STANDARD OVEN THERMOSTAT BY-PASS FLAME ADJUSTMENT

NOTE: By-pass flame can be viewed through the kick panel for adjustment.

1. Turn the thermostat knob to 350°F.
2. Wait 10 minutes for oven to heat up.
3. Turn thermostat knob to lowest setting. **DO NOT TURN OFF.**
4. Remove thermostat knob.
5. With a screwdriver, turn by-pass flame adjustment screw counterclockwise to increase by-pass flame or clockwise to decrease flame until the entire burner has approximately a 1/8" stable flame on each port.

NOTE: Some flickering of the flame is acceptable. This is most likely to occur in the bend of the burner.

BY-PASS FLAME ADJUSTMENT

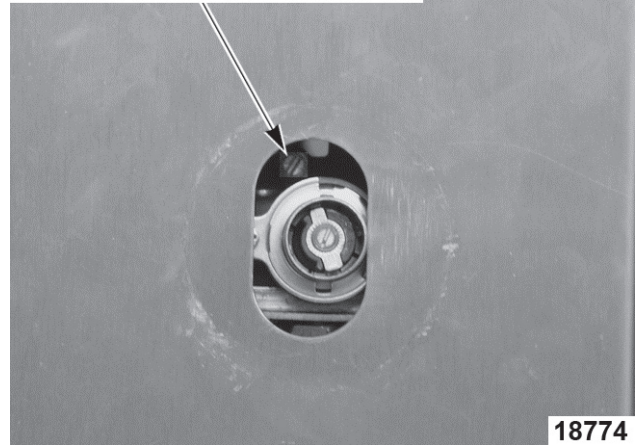

18774

Fig. 59

6. Replace thermostat knob.
 - A. Turn knob to 350°F and verify increase in flame height on burner ports.
7. Turn knob back to lowest setting. Verify decrease in by-pass flame height on burner ports and that burner remains lit.

STANDARD OVEN THERMOSTAT TEMPERATURE ADJUSTMENT

A thermocouple type temperature probe should be placed in center of oven to verify temperatures throughout adjustment.

NOTE: Calibration on this thermostat version is made using the knob for temperature adjustments and not the inner screw as on previous versions.

1. Turn knob to 350°F. Wait 10 minutes for oven to heat up.
2. Turn knob to the lowest setting and check the bypass flame for proper adjustment as outlined under STANDARD OVEN THERMOSTAT BY-PASS FLAME ADJUSTMENT.
3. Turn knob back to 350°F. When the flame stabilizes take a temperature reading. If temperature is more than 15°F from knob setting, calibrate as follows:
4. Pull off knob.
5. Loosen two screws on the back of knob.

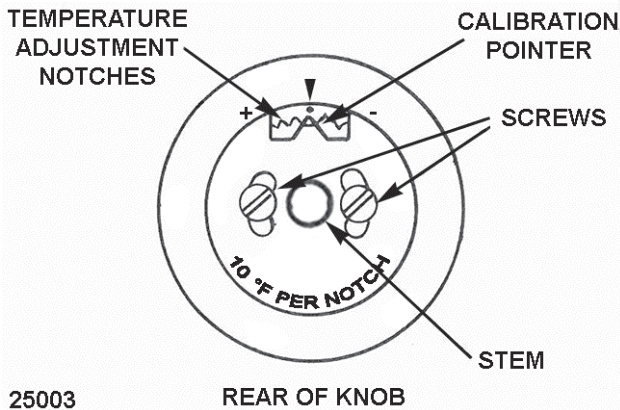

Fig. 60

6. Grasp stem and push it out from knob to clear the temperature adjustment notches. Move calibration pointer at base of stem clockwise to lower temperature or counterclockwise to raise temperature as close to the desired setpoint as possible. Each notch equals 10°F.
7. Tighten screws and replace knob.
8. Verify temperature setting at 400°F and 450°F. Wait 10 minutes for oven to heat up at each setting. If temperature is not within 15°F, replace thermostat and verify calibration.

CONVECTION OVEN THERMOSTAT-COMBO VALVE ADJUSTMENT

Operation

The thermostat-combo valve is self-regulating and the thermostat is internally connected to the valve. When

thermostat dial is set to 350°F and the oven is below setpoint, the valve opens to allow gas flow and burner lights. As the oven temperature rises, the pressure from the sensor bulb in the oven increases. Fluid in the capillary tube expands with the temperature increase and presses against a diaphragm in the thermostat. When the oven temperature reaches setpoint, the internal valve closes to stop gas flow to burner.

When the oven temperature decreases below setpoint, the pressure is reduced in the capillary which reduces the force on the diaphragm allowing the valve to open again.

Adjustment

A thermocouple temperature probe (type K preferred) should be placed in center of oven to verify temperatures throughout adjustment.

1. Turn power switch on.
2. Turn dial to 350°F. Allow oven to cycle 3 complete times.
3. Take a temperature reading. If temperature is more than 20° off dial setting, calibrate as follows.
4. Pull off thermostat knob. Do not rotate knob during removal.
5. Hold outer shaft in place. Do not allow to move.
6. Turn inner screw 1/4 turn clockwise to decrease and counterclockwise to increase. 1/4 turn = 35°F.
7. Verify temperature setting at 350°F. Allow oven to cycle 3 complete times.
8. If not within 20°F then replace thermostat.
9. If temperature is within tolerance, adjustment is complete.
10. Apply a small amount of Loctite 242 (non-permanent type sealer) around the inner screw head to prevent movement.
11. Install knob.

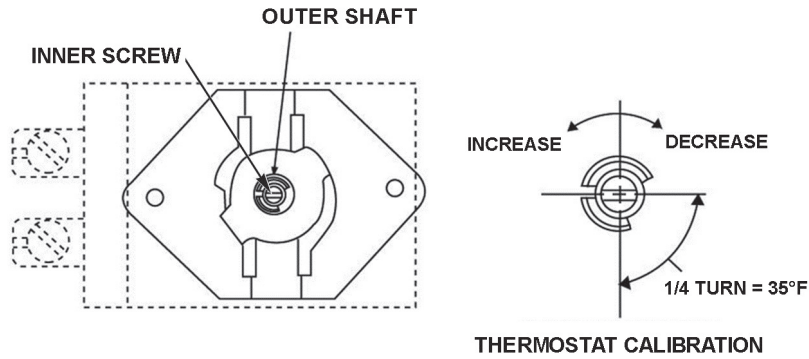

THERMOSTAT CALIBRATION 25043

Fig. 61

GRIDDLE THERMOSTAT-COMBO VALVE ADJUSTMENT

Operation

The thermostat-combo valve is self-regulating and the thermostat is internally connected to the valve. When thermostat dial is set to 350°F and the griddle is below setpoint, the valve opens to allow gas flow and burner lights. As the griddle temperature rises, the pressure from the sensor bulb secured to the bottom of the griddle plate increases. Fluid in the capillary tube expands with the temperature increase and presses against a diaphragm in the thermostat. When the griddle temperature reaches setpoint, the internal valve closes to stop gas flow to burner.

When the griddle temperature decreases below setpoint, the pressure is reduced in the capillary which reduces the force on the diaphragm allowing the valve to open again.

Adjustment

A thermocouple type surface temperature probe should be placed in center of griddle to verify temperatures throughout adjustment.

1. Turn dial to 350°F. Allow griddle to cycle 3 complete times.
2. Take a temperature reading. If temperature is more than 20° off dial setting, calibrate as follows.
3. Pull off thermostat knob. Do not rotate knob during removal.
4. Hold outer shaft in place. Do not allow to move.
5. Turn inner screw 1/4 turn clockwise to decrease and counterclockwise to increase. 1/4 turn = 35°F. See graphic [Fig. 61](#).
6. Verify temperature setting at 350°F. Allow griddle to cycle 3 complete times.
7. If not within 20°F then replace thermostat.

8. If temperature is within tolerance, adjustment is complete.
9. Apply a small amount of Loctite 242 (non-permanent type sealer) around the inner screw head to prevent movement.
10. Install knob.

THERMOCOUPLE TEST

Operation

The thermocouple supplies a DC millivolt signal (MV) to the gas safety valve when heated by the pilot flame. The gas safety valve will shut off gas flow to the pilot and main burner in case of a pilot outage. When energized by the thermocouple voltage, the gas safety valve is held open to permit gas flow to the pilot and provide gas for the burner when the oven thermostat calls for heat. The pilot flame height is controlled by an adjustable needle valve located under a small cover screw on the gas safety valve.

Pilot Checks

If experiencing pilot outages, perform the following:

Visually check pilot flame for the proper contact on thermocouple and adjust as outlined under [PILOT FLAME HEIGHT](#). If adjustment does not result in a pilot flame of proper height, then gas might not be flowing properly to the pilot.

Check for:

- A plugged pilot orifice.
- Kinked or plugged pilot gas tubing.
- Low gas supply pressure.

Thermocouple Checks

NOTE: Tubing connection from the thermocouple tip to gas safety valve is an electrical connection and must be clean and dry. Do not use any sealing compound on the threads of thermocouple nut.

NOTICE Do not overtighten the thermocouple nut or the insulator could be crushed, shorting the thermocouple. Finger tighten the nut plus 1/4 turn with a wrench only.

If pilot flame is correct and there are no excessive air drafts in the room, then problem is either the thermocouple output voltage or the gas safety valve.

Visually check the thermocouple tip (hot end) and tube lead for:

- Loose thermocouple connection (electrical) at the safety valve.
- Corrosion or debris on the threaded connector or thermocouple tip causing a poor electrical connection.
- Kinks or pinches that might cause a short between the tube and the wire inside.

If thermocouple is loose, tighten mounting nut as described above in NOTICE. If thermocouple connection shows signs of corrosion or debris that cannot be cleaned; or damage as described, replace it and check pilot operation as outlined under PILOT FLAME HEIGHT.

Thermocouple Test

Check the thermocouple output voltage (DC millivolts) with a VOM as outlined in the steps below.

- If thermocouple adaptor (see Tools) is available, check *closed* circuit voltage as outlined in the test procedure.
- If thermocouple adaptor is not available, check *open* circuit voltage as outlined in the test procedure.
- If a VOM is not available, replace the thermocouple with a new one as outlined under STANDARD OVEN PILOT ASSEMBLY AND THERMOCOUPLE or CONVECTION OVEN PILOT ASSEMBLY AND THERMOCOUPLE or and check operation GRIDDLE PILOT ASSEMBLY AND THERMOCOUPLE.

1. Disconnect thermocouple from gas safety valve.
2. Select the test to perform.
3. **Closed Circuit.**
 - A. Install thermocouple adaptor at the threaded connection on gas safety valve.
 - B. Install thermocouple to the adaptor. Tighten mounting nut as described above in NOTICE.
 - C. Light the pilot. Allow pilot to heat thermocouple for one to two minutes.

- D. Connect one meter lead to the adaptor test point and the other meter lead to the tube. Compare reading to the value listed in the table below.

4. **Open Circuit**

- A. Connect one meter lead to the tip of the threaded end and the other meter lead to the tube. Compare reading to the values listed in the table below.
- B. Light the pilot and continue to hold red button down during this test. Allow pilot to heat thermocouple for one to two minutes.
- C. Compare reading to the value listed in the table below.

THERMOCOUPLE MV READINGS		
	Closed Circuit	Open Circuit
Range	8 to 25 MV	25 to 35 MV

5. If readings are less than the minimum stated above, replace the thermocouple as outlined under STANDARD OVEN PILOT ASSEMBLY AND THERMOCOUPLE or CONVECTION OVEN PILOT ASSEMBLY AND THERMOCOUPLE or GRIDDLE PILOT ASSEMBLY AND THERMOCOUPLE.
6. If pilot is still not functioning properly after replacing thermocouple, then a problem exists in the gas safety valve. Install a replacement GAS SAFETY VALVE (STANDARD AND CONVECTION OVENS) and check for proper operation.

ELECTRICAL OPERATION

COMPONENT FUNCTION

Power Cord	Connects range to power source.
On/Off Switch	Provides power for the convection oven motor and solenoid valve.
Solenoid Valve	Allows gas flow to the convection oven burner assembly when solenoid is energized by the door switch (normally closed valve).
Door Switch	Removes power from convection motor and solenoid valve when oven door is open (N.O. - held closed).
Convection Oven Motor (Single Phase) . . .	Circulates heated air inside the oven. The motor electrical power is routed through door switch.
Junction Box	Connection point for electrical wires.

SEQUENCE OF OPERATION - CONVECTION OVEN

Refer to AI3549 [SCHEMATIC DIAGRAM - CONVECTION OVENS.](#)

Oven temperature is below set point of control.

Convection Oven

1. Conditions.
 - A. 120VAC to oven controls and is properly grounded.
 - B. Power switch off.
 - C. Door switch held-closed (oven door closed).
 - D. Pilot lit.
 - E. Thermostat-combo valve is off.
 - F. Oven at room temperature.
2. Turn power switch on.
 - A. Solenoid is energized allowing gas flow to thermostat-combo valve.
 - B. Power to oven motor (blower circulates air inside cavity).
3. Set thermostat knob to 350°F.
 - A. Thermostat-combo valve calls for heat and opens internal valve to allow gas flow to burner.
 - B. Pilot lights the burner and heating begins.
4. Oven reaches setpoint temperature. Thermostat-combo valve closes internal valve to stop gas flow to burner.
5. Door switch opened (oven door open).
 - A. Power is removed from oven motor.
6. Oven door closed. Door switch contacts close and oven motor resumes operation.
7. Thermostat-combo valve cycles the burner as required to maintain setpoint temperature until thermostat knob is turned to off; or power switch off.

SCHEMATIC DIAGRAM - CONVECTION OVENS

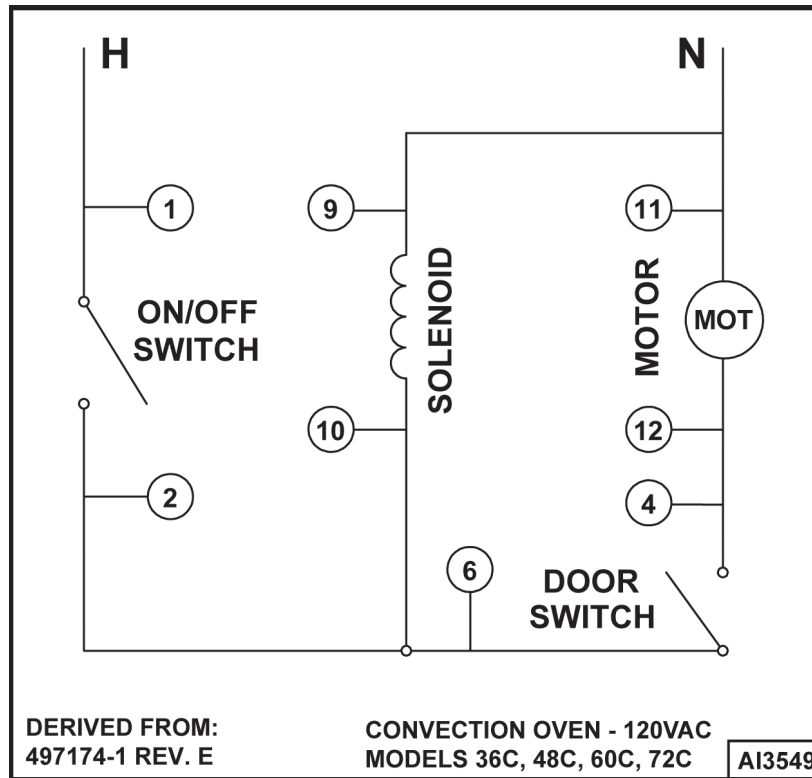

Fig. 62

WIRING DIAGRAM - CONVECTION OVENS

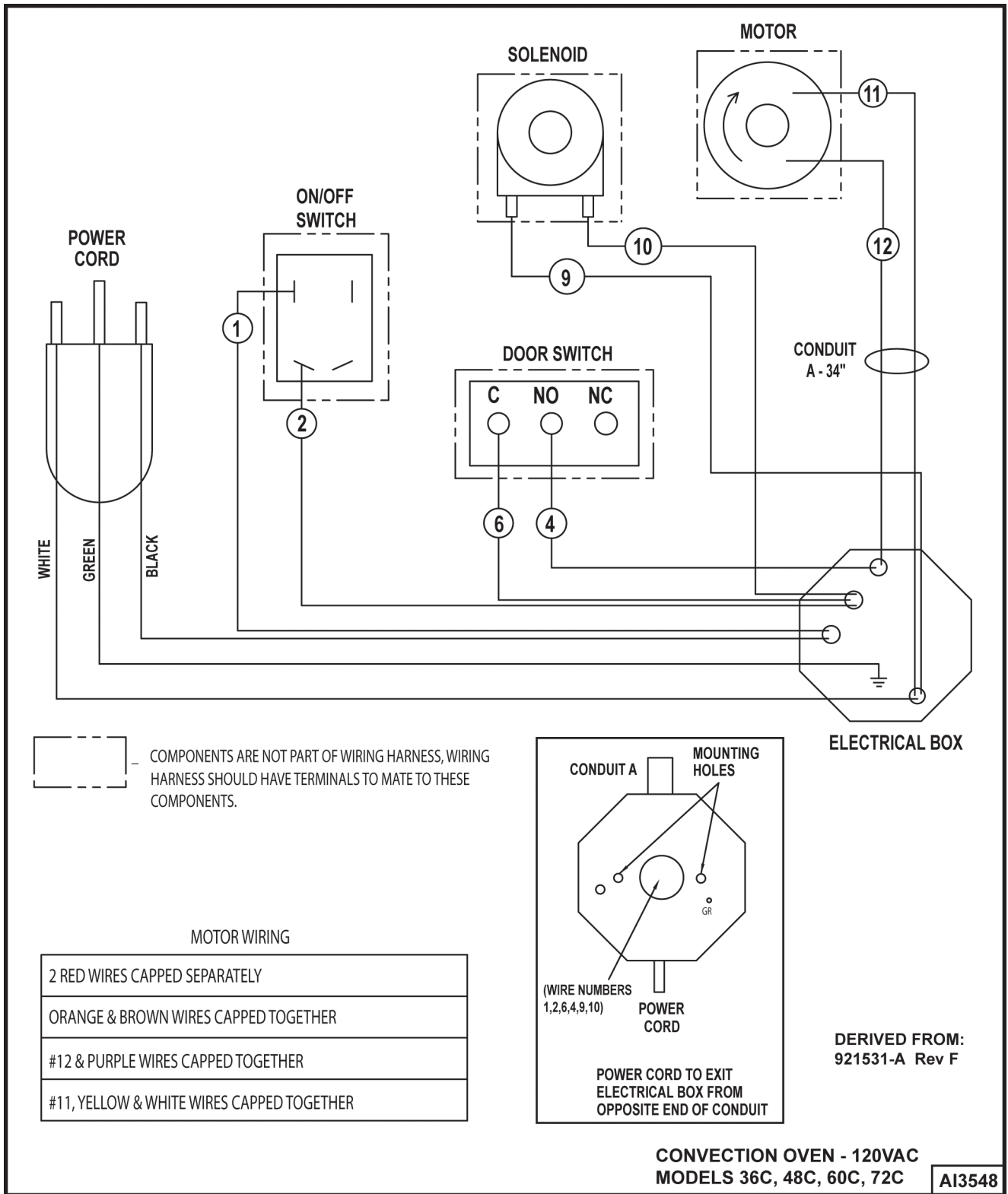

Fig. 63

TROUBLESHOOTING

TROUBLESHOOTING

GENERAL	
SYMPTOM	POSSIBLE CAUSE
Pilot does not remain lit.	<ol style="list-style-type: none"> 1. Incorrect gas pressure. 2. Pilot burner not adjusted properly. 3. Pilot burner blocked. 4. Thermocouple not positioned correctly or malfunctioning. 5. Gas safety valve malfunction. 6. Incorrect oven pilot orifice. 7. Ventilation issue in room (drafts blowing out pilot).
Burner flame too yellow	<ol style="list-style-type: none"> 1. Orifice incorrect size or dirty. 2. Air shutter not adjusted correctly or dirty. 3. Incorrect gas pressure. 4. Incorrect gas type. 5. Orifice misaligned in venturi. 6. Appliance not venting properly.
Slow to heat or not hot enough.	<ol style="list-style-type: none"> 1. Low gas pressure. 2. Thermostat out of calibration.
Oven temperature too hot.	<ol style="list-style-type: none"> 1. Thermostat out of calibration. 2. By-pass flame to high.
Low burner flame (all burners).	<ol style="list-style-type: none"> 1. Low gas pressure. 2. Incorrect gas type.
Low burner flame (individual burner).	<ol style="list-style-type: none"> 1. Air mixture incorrect.
Flame floats on burner.	<ol style="list-style-type: none"> 1. Inadequate air supply. 2. Restricted exhaust flue (ovens).

CONVECTION OVENS ONLY	
SYMPTOM	POSSIBLE CAUSE
Oven temperature too hot.	<ol style="list-style-type: none"> 1. Thermostat out of calibration.
Convection motor does not operate.	<ol style="list-style-type: none"> 1. Main power supply not on. 2. Incorrect voltage. 3. Oven door switch open or inoperative. 4. Power switch open or inoperative. 5. Convection motor inoperative.

CONVECTION OVENS ONLY	
SYMPTOM	POSSIBLE CAUSE
Convection motor noisy.	<ol style="list-style-type: none"> 1. Motor mounting loose. 2. Fan loose on motor shaft. 3. Fan excessively dirty or debris stuck in fan. 4. Motor malfunction.
Pilot does not remain lit (no gas flow to oven burner).	<ol style="list-style-type: none"> 1. Low gas pressure. 2. Thermocouple not positioned correctly or malfunctioning. 3. Solenoid malfunction. 4. Pilot gas flow too low. Adjust on gas safety valve.