

INSTALLATION & OPERATION MANUAL FOR Heavy Duty Gas Griddles

ITW Food Equipment Group

VULCAN

MODEL	MLS
924RE	ML-135221-00G24
936RE	ML-135222-00G36
948RE	ML-135223-00G48
960RE	ML-135224-00G60
972RE	ML-135225-00G72

www.vulcanhart.com



924RE



AGE24



MODELS	MLS
AGE24	ML-135226-00G24
AGE36	ML-135227-00G36
AGE48	ML-135228-00G48
AGE60	ML-135229-00G60
AGE72	ML-135230-00G72

www.wolfrange.com

ITW Food Equipment Group, LLC
3600 North Point Blvd.
Baltimore, MD 21222

RETAIN THIS MANUAL FOR FUTURE USE

FORM F-36958 (4-07)

IMPORTANT FOR YOUR SAFETY

THIS MANUAL HAS BEEN PREPARED FOR PERSONNEL QUALIFIED TO INSTALL GAS EQUIPMENT, WHO SHOULD PERFORM THE INITIAL FIELD START-UP AND ADJUSTMENTS OF THE EQUIPMENT COVERED BY THIS MANUAL.

POST IN A PROMINENT LOCATION THE INSTRUCTIONS TO BE FOLLOWED IN THE EVENT THE SMELL OF GAS IS DETECTED. THIS INFORMATION CAN BE OBTAINED FROM THE LOCAL GAS SUPPLIER.

IMPORTANT

IN THE EVENT A GAS ODOR IS DETECTED, SHUT DOWN UNITS AT MAIN SHUTOFF VALVE AND CONTACT THE LOCAL GAS COMPANY OR GAS SUPPLIER FOR SERVICE.

FOR YOUR SAFETY

DO NOT STORE OR USE GASOLINE OR OTHER FLAMMABLE VAPORS OR LIQUIDS IN THE VICINITY OF THIS OR ANY OTHER APPLIANCE.

WARNING: IMPROPER INSTALLATION, ADJUSTMENT, ALTERATION, SERVICE OR MAINTENANCE CAN CAUSE PROPERTY DAMAGE, INJURY OR DEATH. READ THE INSTALLATION, OPERATING AND MAINTENANCE INSTRUCTIONS THOROUGHLY BEFORE INSTALLING OR SERVICING THIS EQUIPMENT.

IN THE EVENT OF A POWER FAILURE, DO NOT ATTEMPT TO OPERATE THIS DEVICE.

INSTALLATION, OPERATION AND CARE OF HEAVY DUTY GAS GRIDDLES

GENERAL

Heavy Duty Gas Griddles are produced with quality workmanship and materials. Proper installation, usage and maintenance of your griddle will result in many years of satisfactory performance. Thoroughly read this entire manual and carefully follow all of the instructions provided

Model	Number of Burners	BTU/hr Input Rating
924RE, AGE24	2	60,000
936RE, AGE36	3	90,000
948RE, AGE48	4	120,000
960RE, AGE60	5	150,000
972RE, AGE72	6	180,000

INSTALLATION

Before installing, verify that the electrical service and type of gas supply (natural gas or propane) agree with the specifications on the rating plate riveted to the right side of the unit in the upper front corner. If the supply and equipment requirements do not agree, do not proceed with the installation. Contact your dealer immediately.

UNPACKING

This griddle was inspected before leaving the factory. The transportation company assumes full responsibility for safe delivery upon acceptance of shipment. Check for possible shipping damage immediately after unpacking. If the griddle is found to be damaged, save the packaging material and contact the carrier within 15 days of delivery.

Carefully unpack your griddle and make sure that no parts are discarded with packaging material. A pressure regulator designed to operate with the griddle has been supplied and must be installed before the griddle is placed into service (Refer to GAS PRESSURE REGULATOR INSTALLATION in this manual).

LOCATION

The installation location must be kept free and clear of combustibles. When installing, never enclose the bottom of the griddle with a raised curb or other constructions that would obstruct flow of air into or out of the griddle. Adequate clearance for air openings into the combustion chamber must be provided. Make sure there is an adequate supply of air in the room to replace air taken out by the ventilation system.

Do not permit air to blow directly at the griddle. Avoid open windows next to the griddle wherever possible. Avoid wall-type fans which create air cross-currents within the room.

This griddle is Design Certified for installation on a non-combustible counter with 4" legs, or combustible floor with 25" high stand.

INSTALLATION CLEARANCES

	COMBUSTIBLE CONSTRUCTION	NON-COMBUSTIBLE CONSTRUCTION
Back:	6"	0"
Right Side:	6"	0"
Left Side	6"	0"

INSTALLATION CODES AND STANDARDS

The griddle must be installed in accordance with:

In the United States of America:

1. State and local codes.
2. National Fuel Gas Code, ANSI-Z223.1/NFPA #54 (latest edition). This shall include but not be limited to: NFPA #54 Section 10.3.5.2 for Venting. Copies may be obtained from The American Gas Association Accredited Standards Committee Z223, @ 400 N. Capital St. NW, Washington, DC 20001 or the Secretary Standards Council, NFPA, 1 Batterymarch Park Quincy, MA 02169-7471

NOTE: In the Commonwealth of Massachusetts

All gas appliances vented through a ventilation hood or exhaust system equipped with a damper or with a power means of exhaust shall comply with 248 CMR.

3. NFPA Standard # 96 *Vapor Removal from Cooking Equipment*, latest edition, available from the National Fire Protection Association, Batterymarch Park, Quincy, MA 02269.

In Canada:

1. Local codes.
2. CAN/CSA-B149.1 Natural Gas Installation (latest edition)
3. CAN/CSA-B149.2 Propane Installation Code (latest edition), available from the Canadian Gas Association, 178 Rexdale Blvd., Etobicoke, Ontario, Canada M9W 1R3

GAS CONNECTIONS

CAUTION: Gas supply connections and any pipe joint compound must be resistant to the action of propane gases.

Use a ¾" NPT gas supply line for the griddle inlet, located at the rear of the griddle. All of flexible and semi-rigid gas supply lines must comply with the applicable ANSI standard. To ensure maximum operating efficiency this appliance must be connected with a gas supply line of solid pipe or a commercial type Flexible Connector with the net inside diameter (I.D.) as large as or larger than the gas pipe inlet on this appliance. Codes require that a gas shutoff valve must be installed in the gas line upstream of the griddle.

WARNING: PRIOR TO LIGHTING CHECK ALL JOINTS IN THE GAS SUPPLY LINE FOR LEAKS. USE SOAP AND WATER SOLUTION. DO NOT USE AN OPEN FLAME.

After checking for leaks all lines receiving gas should be fully purged to remove air.

GAS PRESSURE REGULATOR INSTALLATION

Gas regulator pressure is preset at 5" Water Column (W.C.) for natural gas, and 10" W.C. for propane gas. Minor adjustments may be required based on site specific gas pressure.

Install the regulator as close to the griddle on the gas supply line as possible. Make sure that the arrow on the underside of the regulator is oriented in the direction of gas flow to the griddle (Fig. 1) and the regulator is positioned with the vent plug and adjustment screw upright (Fig. 2).

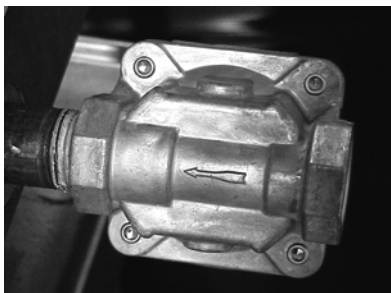

Fig. 1



Fig. 2

The minimum supply pressure (upstream of the regulator) should be 7-9" W.C. for natural gas and 11-12" W.C. for propane gas. At no time should the griddle be connected to supply pressure greater than ½ psig (3.45 kPa) or 14" W.C.

TESTING THE GAS SUPPLY SYSTEM

When the gas supply pressure exceeds ½ psig (3.45 kPa), the griddle and its individual shutoff valve must be disconnected from the gas supply piping system.

When the gas supply pressure is ½ psig (3.45 kPa) or less, the griddle should be isolated from the gas supply system by closing its individual manual shutoff valve.

ELECTRICAL CONNECTIONS

Power supply for electric thermostats is 120 volts, 5 amps, 50/60 Hertz, 1 phase. Do not connect the griddle to electrical supply until after gas connections are made.

WARNING: ELECTRICAL AND GROUNDING CONNECTIONS MUST COMPLY WITH THE APPLICABLE PORTIONS OF THE NATIONAL ELECTRICAL CODE AND/OR OTHER LOCAL ELECTRICAL CODES.

WARNING: DISCONNECT THE ELECTRICAL POWER TO THE GRIDDLE AND FOLLOW LOCKOUT / TAGOUT PROCEDURES.

WARNING: APPLIANCES EQUIPPED WITH A FLEXIBLE ELECTRIC SUPPLY CORD ARE PROVIDED WITH A THREE-PRONG GROUNDING PLUG. IT IS IMPERATIVE THAT THIS PLUG BE CONNECTED INTO A PROPERLY GROUNDED THREE-PRONG RECEPTACLE. IF THE RECEPTACLE IS NOT THE PROPER GROUNDING TYPE, CONTACT AN ELECTRICIAN. DO NOT REMOVE THE GROUNDING PRONG FROM THIS PLUG.

GRIDDLES MOUNTED ON STANDS WITH CASTERS

Griddles mounted on stands with casters must use a flexible connector (not supplied) that complies with the Standard for Connectors for Movable Gas Appliances ANSI Z21.69•CSA6.16, and a quick-disconnect device that complies with Gas Fuel, ANSI Z21.3•CSA6.9. In addition, adequate means must be provided to limit movement of the appliance without depending on the connector and the quick-disconnect device (or its associated piping) to limit appliance movement. Attach the restraining device at the rear of the griddle as shown in Fig. 3.

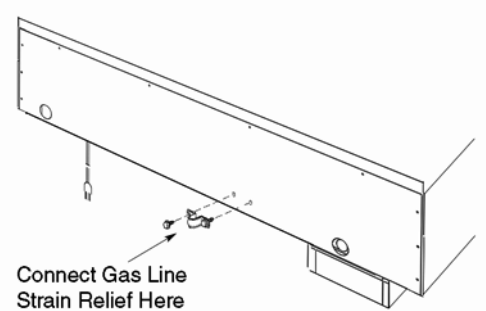

Fig. 3.

If disconnection of the restraint is necessary, turn off the gas supply before disconnecting. Reconnect the restraint prior to turning the gas supply on and returning the griddle to its installation position.

Castors are only supplied on a griddle stand. If the griddle is moved for any reason the griddle should be re-leveled (see LEVELING in this manual).

FLUE CONNECTIONS

DO NOT obstruct the flow of flue gases from the flue, located at the rear of the griddle. It is recommended that flue gases be ventilated to the outside of the building through a ventilation system installed by qualified personnel.

From the termination of the flue to the filters of the hood venting system, a minimum clearance of 18" must be maintained.

Information on the construction and installation of ventilating hoods may be obtained from the standard for "Vapor Removal from Cooking Equipment", NFPA No. 96 (latest edition), available from the National Fire Protection Association, Batterymarch Park, Quincy, MA 02269.

ADJUSTMENTS

LEVELING

The griddle must be level (side-to-side and front-to-back) during operation to ensure proper performance. Improper leveling can result in uneven temperature distribution, cold spots, and possibly damage electrical components.

1. Place a level on the griddle.
2. Adjust legs by turning the bullet feet at the bottom of each leg. Using pliers or a crescent wrench, turn the feet counter-clockwise to increase height, and clockwise to decrease height until leveling is achieved. Do not extend the legs more than 1- $\frac{3}{4}$ ".

PILOT ADJUSTMENT

Remove front panel. Using a flathead screwdriver, turn the slotted hex-head pilot adjustment screw clockwise to decrease the flame, and counterclockwise to increase the flame. Pilot adjustments should only be performed by qualified Service Personnel.

CALIBRATION

1. Each thermostat controls a 12" zone of the griddle. Using a Surface Probe temperature measurement device, observe the temperatures at the center points of the cooking zones. These points are located by starting 6" from the side splash (left or right) and every 12" across the width of the griddle, with all points located 12" back from the front edge of the griddle plate.

NOTE: Use of infrared thermometers is not recommended. These devices are highly sensitive to surface color (clean or dirty), angle of reading and distance from the unit.

2. Set thermostats to 350°F and allow to stabilize, allowing the indicator light to cycle ON and OFF at least two times.
3. Watch for indicator light to cycle OFF, then measure the temperature for that zone. The temperature should be 350°F ±15°F. If not, continue to Step 4.

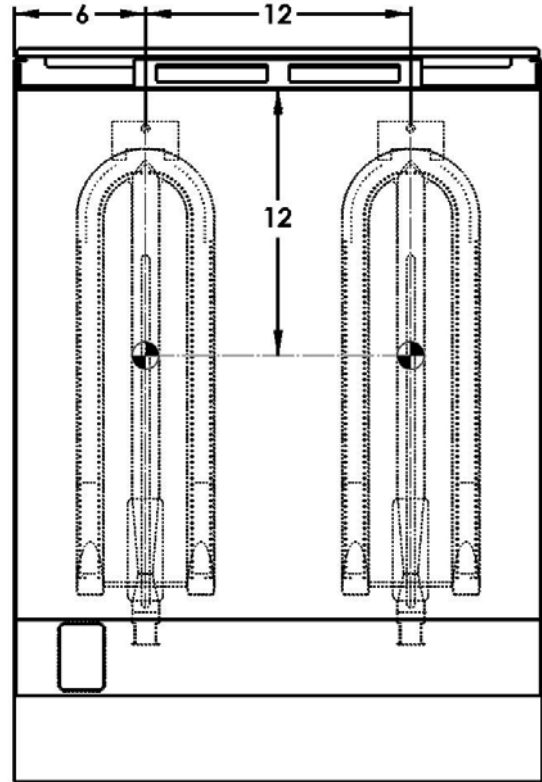

4.
 - a. Carefully loosen the knob set screw. DO NOT allow the knob to turn. Carefully remove the knob from the thermostat shaft, exposing the temperature dial.
 - b. Loosen screws on the temperature dial and adjust so that the temperature indicated by the knob arrow matches the griddle plate temperature reading. Knob will have to be placed back on the shaft to verify adjustment.

IMPORTANT: NEVER ADJUST THE SCREW IN THE CENTER OF THE THERMOSTAT SHAFT. This will ruin the factory calibration; the thermostat will no longer operate properly and will need to be replaced.

5. Once calibration is achieved, tighten the temperature dial screws and knob set screws.



Step 4a. Set knob & check Temperature.
Remove knob



Step 4b. – Adjust temperature dial & verify temperature setting



Step 5 –Replace knob & tighten screws

OPERATION

WARNING: THE GRIDDLE AND ITS PARTS ARE HOT. USE CARE WHEN OPERATING, CLEANING OR SERVICING.

BEFORE FIRST USE

Before leaving the factory the griddle is coated with vegetable oil as a rust inhibitor. Remove this film when the griddle plate is being cleaned prior to its first cooking use. Heat the griddle to 200-300°F to loosen and melt the coating, then clean the surface with a non-corrosive, grease dissolving commercial cleaner, following the manufacturer's directions. Rinse thoroughly and wipe dry with a soft clean cloth. Clean all accessories.

SEASONING THE GRIDDLE

Season the griddle to avoid possible surface corrosion before first use, and after every cleaning. Heat griddle to a low temperature (300-350°F) and apply a small amount of cooking oil – about one ounce per square foot of surface. Use a soft lint-free cloth to spread the oil over the entire griddle surface to create a thin film. Wipe off any excess oil with a cloth. Repeat the procedure until the griddle has a slick, mirror-like finish.

CONTROLS

THERMOSTAT – Each thermostat controls the gas flow to the burner to bring that area of the griddle plate up to the set temperature. Indicator lights indicate when a gas valve is open and a burner is active.

POWER SWITCH – activates/deactivates electrical power to the griddle. Unit will only operate if power is on.

INDICATOR LIGHT – each burner has an associated light that will illuminate when the burner is in operation.

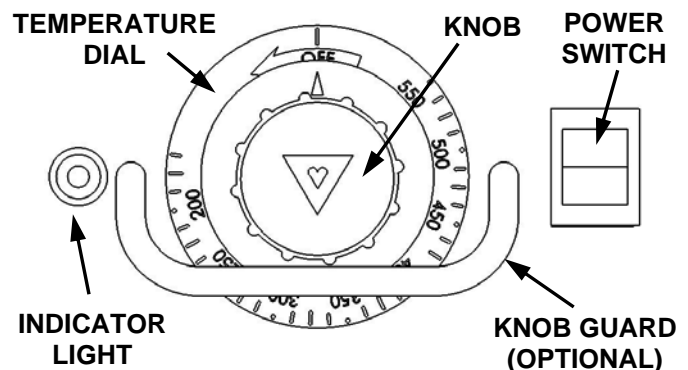

OPERATION OF GRIDDLE WITH ELECTRONIC IGNITION SYSTEM

1. Set the cooking temperature of each thermostat to be used.
2. Push ON/OFF switch to ON. The red indicator light will glow, indicating the griddle is on and calling for heat.

SHUTDOWN OF GRIDDLE WITH ELECTRONIC IGNITION SYSTEM

1. Push ON/OFF switch to OFF. Red indicator light will stop glowing; indicating that gas has been shut off to main burners and the griddle is not heating.

EXTENDED SHUTDOWN

1. Shut off the main gas supply valve.
2. Unplug the griddle electrical supply cord.
3. Apply a heavy coat of vegetable oil over the griddle plate to inhibit rust.

USING THE GRIDDLE

Each 12" section of the griddle is independently controlled by a thermostat. Turn the thermostat(s) to the desired setting.

To preheat, turn the burners on about 20-25 minutes before cooking.

A uniform and systematic approach to loading the griddle will produce the most consistent product results.

The griddle plate is steel, but the surface is relatively soft and can be scored or dented by careless use of a spatula or scraper. Be careful not to dent, scratch, or gouge the plate surface. Do not try to knock off loose food that may be on the spatula by tapping the corner or the edge of the spatula on the griddle surface.

ZONE COOKING

This griddle features a tubular U-shaped burner in 12" sections, each controlled by independent thermostats. Each 12" section is a separate cooking zone, and allows cooking a wide variety of products over a single griddle plate. The chart below is a suggested usage of zone cooking.

When zone cooking, it is suggested that you start with your lowest temperature setting at either side of the griddle, increasing the zone temperature as you move up the zone line. These zone cooking guidelines will vary depending on product temperatures, size and shape.

This guide should be adjusted to suit your product and operational cooking preference.

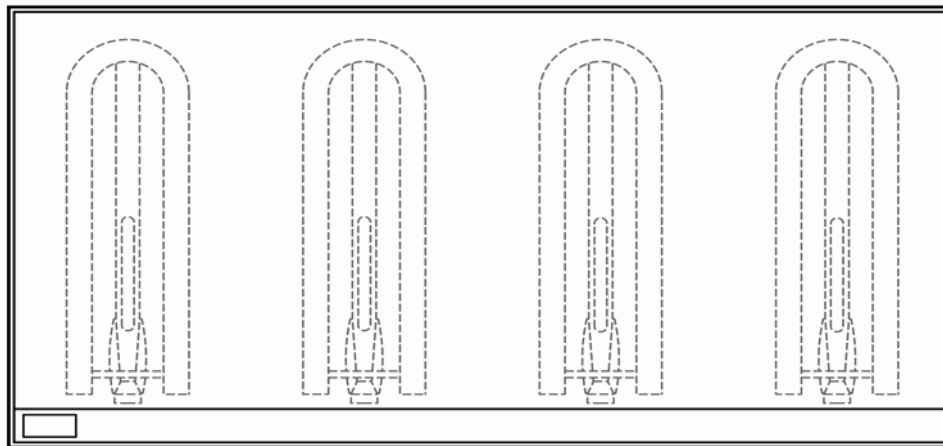

ZONE 1 (300°F)	ZONE 2 (350°F)	ZONE 3 (350°F)	ZONE 4 (400°F)
PRODUCT Sausage Eggs (Hard Fried) Eggs (Scrambled) Burger (Well Done) Steak (Well Done) Chicken Breast Frozen Foods Pork Chops	PRODUCT Pancakes French Toast Bacon Eggs (Sunny Side Up) Boiled Ham Steak (Medium Well) Fresh Burger (Medium Well) Small Frozen Burger (Medium Well)	PRODUCT Omelet Hash Browns Canadian Bacon	PRODUCT Steak (Rare) Stir Fry Vegetables Salmon Fish Cakes Lobster Scampi

CLEANING THE GRIDDLE

WARNING: DISCONNECT THE ELECTRICAL POWER TO THE APPLIANCE AND FOLLOW LOCKOUT/TAGOUT PROCEDURES.

Empty the grease drawer as needed throughout the day and regularly clean at least once daily.

Clean the griddle regularly. A clean griddle always looks better, lasts longer and performs better. To produce evenly cooked, perfectly browned griddle products keep the griddle plate clean and free of carbonized grease. Carbonized grease on the surface hinders the transfer of heat from the griddle surface to the food, resulting in spotty browning and loss of cooking efficiency. Carbonized grease tends to cling to griddle foods, giving them a highly unsatisfactory and unappetizing appearance.

To keep the griddle clean and operating at peak efficiency, follow these procedures:

AFTER EACH USE

Clean the griddle with a wire brush or flexible spatula.

ONCE PER DAY

Thoroughly clean the griddle back splash, sides and front. Remove, empty and wash the grease drawer in the same manner as an ordinary cooking utensil.

ONCE PER WEEK

Clean the griddle surface thoroughly. Use a griddle stone, screen, or Scotch Bright pad on the surface as necessary. Rub with the grain of the metal while the griddle is still warm (not hot). A detergent may be used on the plate surface to help clean it, but be sure the detergent is thoroughly removed by flushing with clear water.

After removal of detergent the surface of the plate the griddle should be seasoned according to the instructions in this manual.

Clean stainless steel surfaces with a damp cloth and polish with a soft dry cloth. To remove discoloration, use a griddle cleaner.

If the griddle usage is very high, consider conducting this weekly cleaning procedure more than once per week.

CLEANING A CHROME GRIDDLE PLATE

AFTER EACH USE

Clean the griddle with a palmetto brush or flexible spatula. NEVER USE AN ABRASIVE SCOURING PAD OR GRIDDLE STONE ON A CHROME PLATE SURFACE.

ONCE PER DAY

Thoroughly clean backsplash, sides, and front. Do not hit the backsplash with a spatula or any other tool. This may create a gap between the splash and griddle plate that is hard to clean.

Clean stainless steel and chrome surfaces with a damp cloth and polish with a soft dry cloth.

MAINTENANCE

WARNING: THE GRIDDLE AND ITS PARTS ARE HOT. USE CARE WHEN OPERATING, CLEANING OR SERVICING THE GRIDDLE.

WARNING: DISCONNECT THE ELECTRICAL POWER TO THE APPLIANCE AND FOLLOW LOCKOUT/TAGOUT PROCEDURES.

LUBRICATION

All valves and thermostats must be checked and lubricated periodically. Check with your Service Agency for details.

VENT / FLUE

Periodically, when the griddle is cool, check the flue and clear any obstructions.

SERVICE AND PARTS INFORMATION

Contact the Service Agency in your area to obtain service and parts information. For a complete listing of Service and Parts depots refer to www.vulcanhart.com or www.wolfrange.com.

When calling for service the following information should be available from the appliance serial plate: Model Number, Serial Number, Gas Type and Voltage.

ACCESSORIES

STANDS

The griddle has an optional 24" high by 30" deep by 24", 36", 48", 60" or 72" wide stainless steel stand with casters or flanged legs. The front casters lock, and flanged legs may be bolted to the floor. The stand includes a top shelf with marine edges style lip and a lower shelf. When mounted on a stand with standard legs and properly leveled, the griddle plate cooking surface should be approximately 36" from the floor.

CUTTING BOARDS & TOWEL BARS

Refer to the installation instructions provided with the cutting board or towel bar kit.

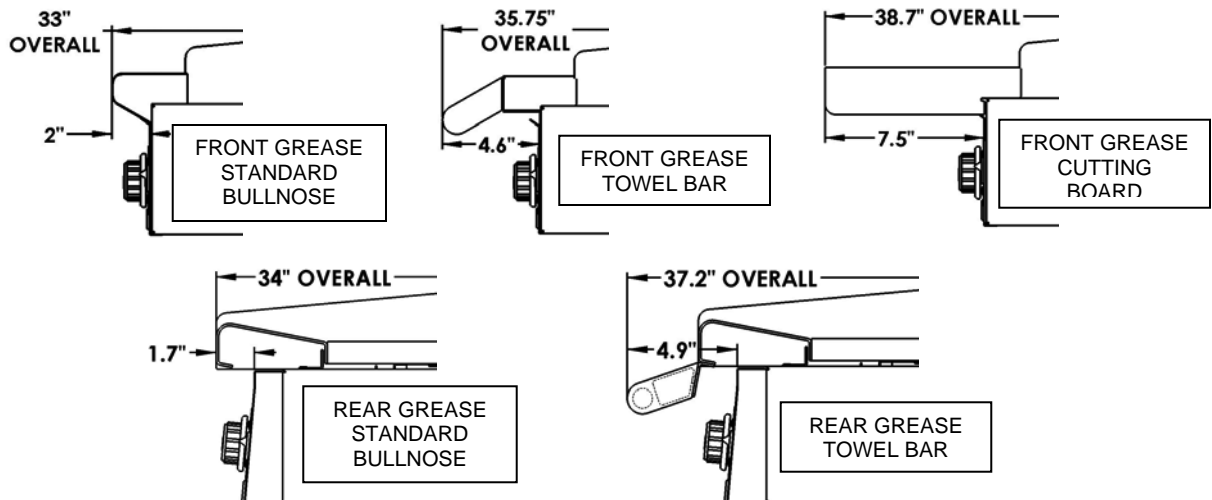

TROUBLESHOOTING

PROBLEM	POSSIBLE CAUSES
Heat does not come on when the thermostat is turned on	<ol style="list-style-type: none"> 1. No power to unit – verify unit plugged. Check circuit breaker or GFI (Ground Fault Indicator). 2. Problem with thermostat. (Call for service) 3. Loose wiring connection. (Call for service) 4. Pilot burner not lit. (Call for service) 5. Problem with gas valve (Call for service) 6. Problem with flame switch/thermocouple. (Call for service)
Pilot burner will not light	<ol style="list-style-type: none"> 1. No power to unit – verify unit plugged. Check circuit breaker or GFI (Ground Fault Indicator). 2. Manual gas valve not turned on. 3. Problem with on/off switch (Call for service) 4. Obstructed pilot orifice. (Call for service) 5. Pilot gas turned off at automatic pilot. (Call for service) 6. Problem with automatic pilot valve. (Call for service) 7. Problem with spark igniter module. (Call for service)
Pilot burner will not stay lit	<ol style="list-style-type: none"> 1. Low gas pressure - problem with regulator or system gas pressure. (Verify or Call for Service) 2. Obstructed or wrong size pilot orifice. (Call for service) 3. Gas supply not purged of air. (Call for service) 4. Air blowing pilot out. (Call for service) 5. Problem with automatic pilot valve (Call for service)
Fat appears to smoke excessively	<ol style="list-style-type: none"> 1. Temperature set too high. 2. Moisture in food may be turning into steam
Food sticks to griddle or burned around edges or contains dark specs	<ol style="list-style-type: none"> 1. Temperature set too high. 2. Griddle surface requires cleaning and/or seasoning. 3. Surface under food not covered with enough cooking oil.
Food under-cooked inside	<ol style="list-style-type: none"> 1. Temperature set too high. 2. Food not cooked for long enough time.
Food tastes greasy or has objectionable off-flavor	<ol style="list-style-type: none"> 1. Food itself may have off-flavor. 2. Food stored improperly before cooking. 3. Too much griddle fat used. 4. Temperature set too low.
Noticeable build-up of gum on griddle	<ol style="list-style-type: none"> 1. Temperature set too high. 2. Griddle surface requires cleaning and/or seasoning. 3. Too much griddle fat used.