

## ENDURANCE SERIES GAS RANGES

### MODELS

G36	G36C
G60	G60C
G260	G260C
G481	G481C

### - NOTICE -

This manual is prepared for the use of trained Vulcan Service Technicians and should not be used by those not properly qualified. If you have attended a Vulcan Service School for this product, you may be qualified to perform all the procedures described in this manual.

This manual is not intended to be all encompassing. If you have not attended a Vulcan Service School for this product, you should read, in its entirety, the repair procedure you wish to perform to determine if you have the necessary tools, instruments and skills required to perform the procedure. Procedures for which you do not have the necessary tools, instruments and skills should be performed by a trained Vulcan Service Technician.

Reproduction or other use of this Manual, without the express written consent of Vulcan, is prohibited.

For additional information on Vulcan-Hart or to locate an authorized parts and service provider in your area, visit our website at [www.vulcanhart.com](http://www.vulcanhart.com)

# TABLE OF CONTENTS

GENERAL .....	3
Introduction .....	3
Installation .....	3
Operation .....	3
Cleaning .....	3
Lubrication .....	3
Specifications .....	3
Tools .....	3
REMOVAL AND REPLACEMENT OF PARTS .....	4
Covers and Panels .....	4
Oven Manifold Cover (Models 60, 260, and 481) .....	4
Oven Control Panel (Model 36) .....	4
Broiler Manifold Cover .....	5
Kick Panel Assembly .....	5
Standard Oven Control Valve/Thermocouple .....	6
Model 36 Only .....	6
Model 60, 260, and 481 .....	7
Oven Pilot Assembly .....	8
Oven Burner Assembly .....	8
Convection Oven Control Valve/Thermocouple Pilot .....	9
Oven Burner Nozzle and Orifice .....	10
Pilot Valve and Quick Disconnect Valve .....	10
Top Section Burner Valve .....	11
Switch Replacement .....	11
Motor Replacement .....	11
Convection Oven Solenoid .....	12
SERVICE PROCEDURES AND ADJUSTMENTS .....	13
Pilot Flame Height .....	13
Top Burners .....	13
Broiler/Griddle .....	13
Air Shutter Adjustment .....	13
Oven Burner Adjustment .....	13
Regulator Check .....	14
Regulator Adjustment .....	14
Oven Burner Nozzle and Orifice Check .....	15
Convection Oven Motor and Door Switch Check .....	15
Convection Oven Solenoid Check .....	16
ELECTRICAL OPERATION .....	18
Component Function .....	18
Sequence of Operation .....	18
Schematic Diagram .....	19
Wiring Diagrams .....	20
Double Oven 120 Volt Endurance Convection Range (Drawing 1 of 2) .....	20
Double Oven 120 Volt Endurance Convection Range (Drawing 2 of 2) .....	21
TROUBLESHOOTING .....	22
CONDENSED SPARE PARTS LIST .....	23

©VULCAN 2005

# GENERAL

## INTRODUCTION

Procedures in this manual will apply to all models unless specified. Pictures and illustrations can be of any model unless the picture or illustration needs to be model specific.

## INSTALLATION

Refer to the Installation and Operation Manual for detailed installation instructions on ranges.

## OPERATION

Refer to the Installation and Operation Manual for specific operating instructions.

## CLEANING

Refer to the Installation and Operation Manual for specific cleaning instructions.

## LUBRICATION

The blower motor has sealed bearings and requires no additional lubrication.

## TOOLS

### Standard

- Standard set of hand tools.
- VOM with A.C. current tester (Any quality VOM with a sensitivity of at least 20,000 ohms per volt can be used).
- Gear puller to remove blower.

### Special

- Temperature tester (thermocouple type).
- Manometer.

## SPECIFICATIONS

### Electrical (Convection ranges only)

- Voltage - 120/60/1 or 240/60/1 (optional)
- Amps - 15 Amps
- Frequency - 50/60 Hz

### Gas Line Pressures

- Natural - Recommended (in. W.C.) 7.0, min 5.0
- Propane - Recommended (in. W.C.) 11.0, min 11.0  
Maximum 14.0 in. W.C. (Nat. or Prop.)

### Orifice Size Requirements for Different Elevations for Restaurant Range

	OPEN TOP	GRIDDLE	BRO/GRID (STD)	OVEN (CON)	OVEN
INPUT AT SEA LEVEL PER BURNER (BTU'S)	32000/35000	15,000	10,000	35,000	35,000
ORIFICE SIZE	NAT/PROP	NAT/PROP	NAT/PROP	NAT/PROP	NAT/PROP
SEA LEVEL TO 2499 FT	36/51 (32000) 33/1.75MM (35000)	50/57	53/63	33/51	33/51
2499 FT TO 4499 FT	40/53 (32000) 37/52 (35000)	51/57	54/65	37/52	37/52
4500 FT TO 6499 FT	41/53 (32000) 38/52 (35000)	51/58	54/65	38/52	38/52
6500 FT TO 8499 FT	42/53 (32000) 40/53 (35000)	52/59	55/66	40/53	40/53
8500 FT TO 10,500 FT	42/54 (32000) 41/53 (35000)	52/60	55/67	41/53	41/53

# REMOVAL AND REPLACEMENT OF PARTS

## COVERS AND PANELS



**WARNING:** DISCONNECT THE ELECTRICAL POWER TO THE MACHINE AND FOLLOW LOCKOUT / TAGOUT PROCEDURES.

### Oven Manifold Cover (Models 60, 260, and 481)

1. Rotate the yellow gas shut-off valve to the OFF position and allow range to cool.

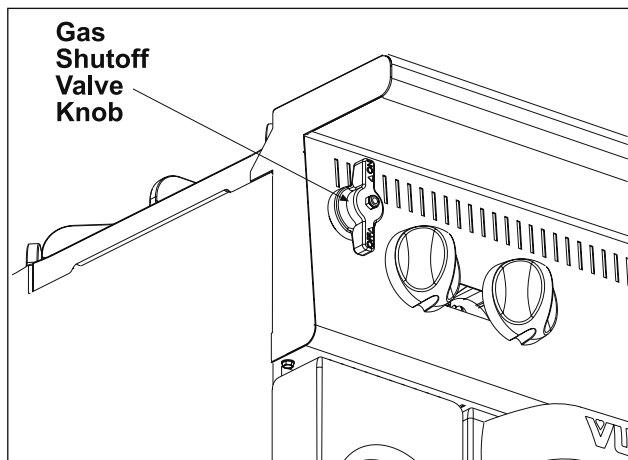

2. Loosen the setscrew in the side of the burner control knobs and oven control knob and remove knobs.

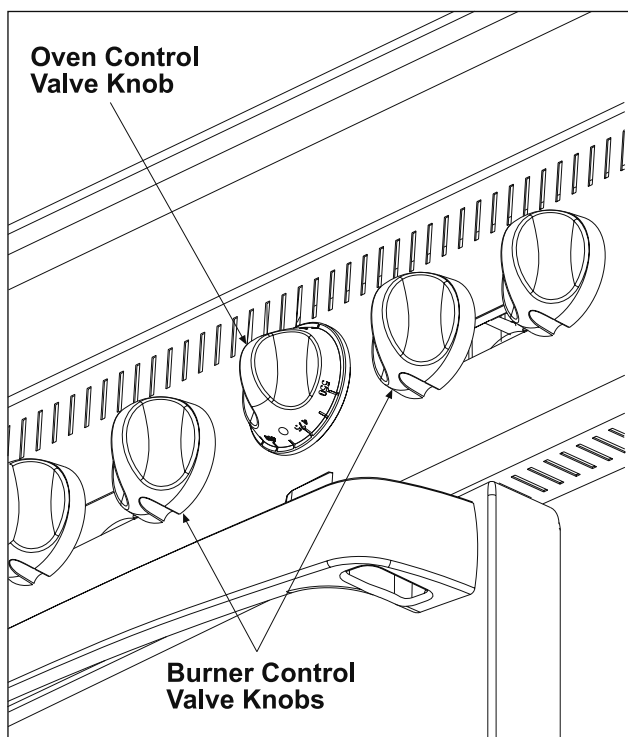

3. Remove screws holding manifold cover in place and remove manifold cover.

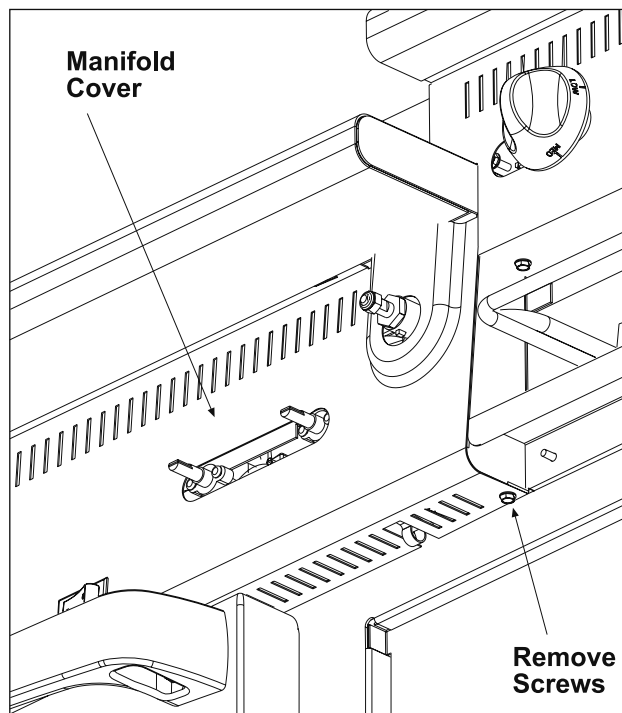

4. Reverse the procedure to install the oven manifold cover.

### Oven Control Panel (Model 36)

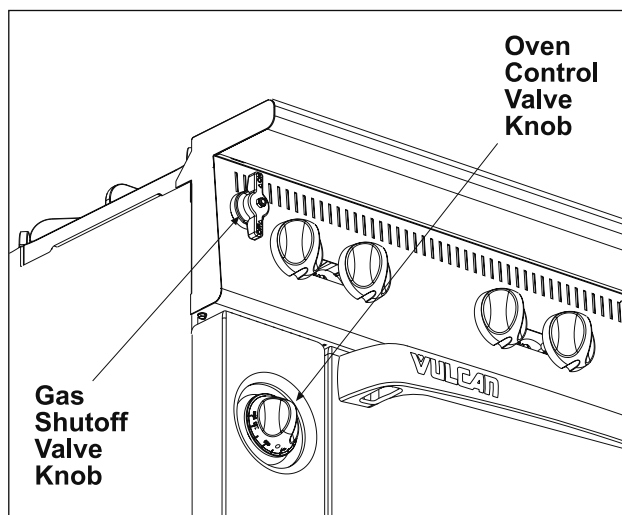

1. Rotate the yellow gas shut-off valve to the OFF position and allow range to cool.
2. Remove the red oven control valve knob from the control valve.
3. Open the kick plate at the bottom of the range.

4. Remove the screw securing the oven control panel and remove the panel.

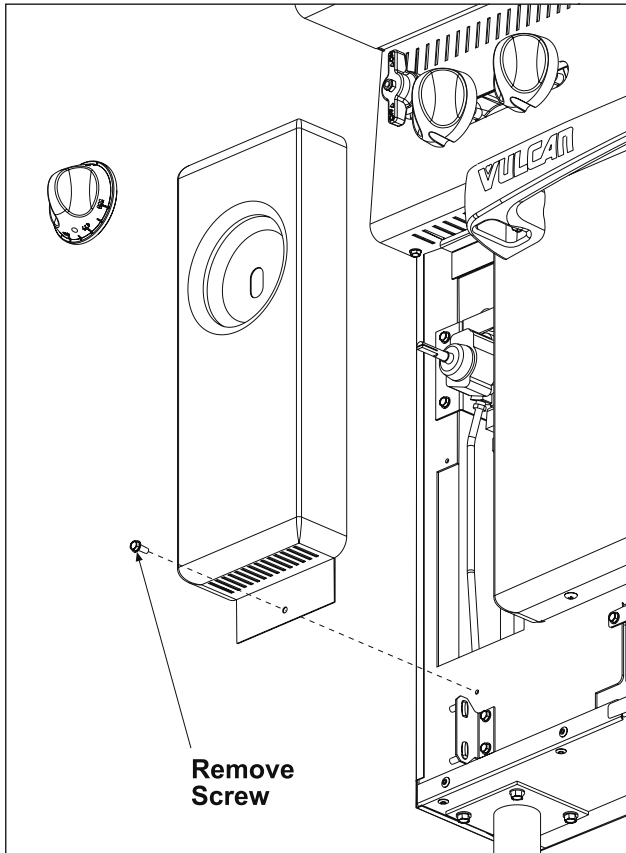

5. Reverse the procedure to install the oven control panel.

#### Broiler Manifold Cover

1. Rotate the yellow gas shut-off valve to the OFF position and allow range to cool.
2. Loosen the setscrew in the side of the burner control knobs and remove knobs.

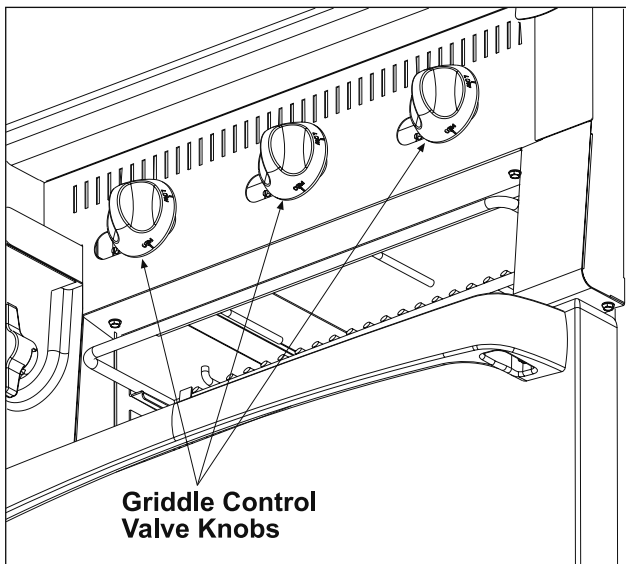

3. Remove screws holding manifold cover in place and remove broiler manifold cover.

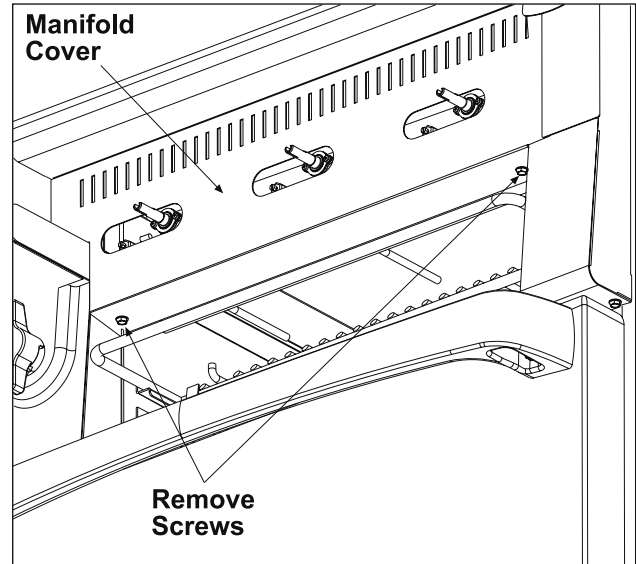

4. Reverse the procedure to install the broiler manifold cover.

#### Kick Panel Assembly

1. Open kick panel.
2. Remove two screws securing left hinge and remove hinge.

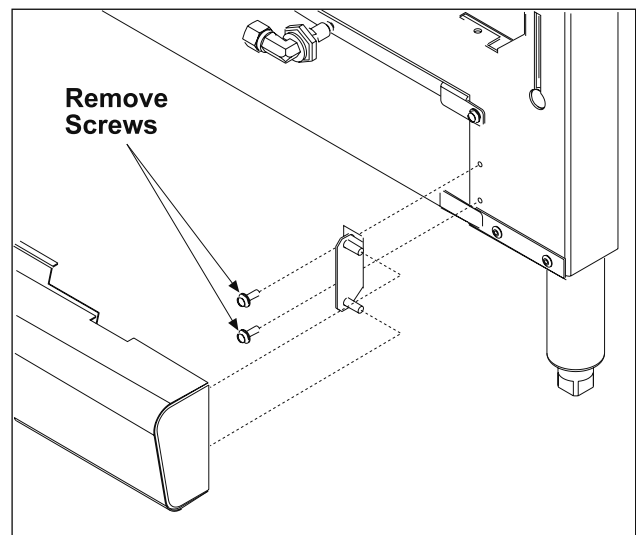

3. Slide kick plate to the left to disengage from left hinge.
4. Reverse the procedure to install the kick plate assembly.

## STANDARD OVEN CONTROL VALVE/THERMOCOUPLE



**WARNING:** DISCONNECT THE ELECTRICAL POWER TO THE MACHINE AND FOLLOW LOCKOUT / TAGOUT PROCEDURES.

**WARNING:** SHUT OFF THE GAS BEFORE SERVICING THE UNIT.

**WARNING:** ALL GAS JOINTS DISTURBED DURING SERVICING MUST BE CHECKED FOR LEAKS. CHECK WITH A SOAP AND WATER SOLUTION (BUBBLES). DO NOT USE AN OPEN FLAME.

### Model 36

The oven control valve is located to the front left of the oven.

1. Remove the oven control panel as outlined under PANELS AND COVERS.
2. Remove the three bracket screws attaching the thermocouple valve mounting bracket to the range.

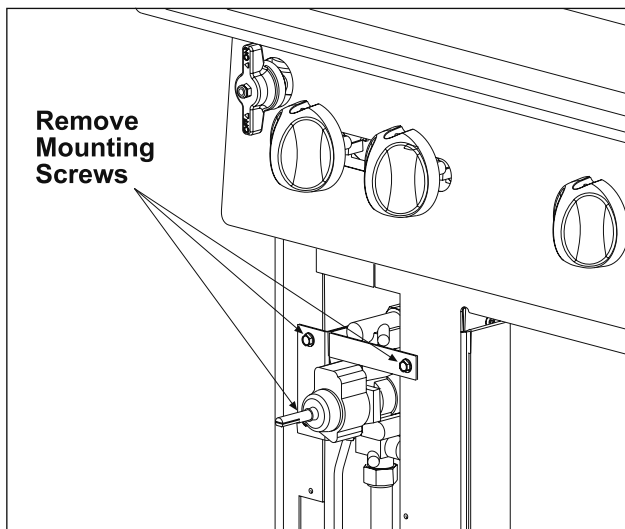

3. Remove the two screws attaching the bracket to the thermocouple.

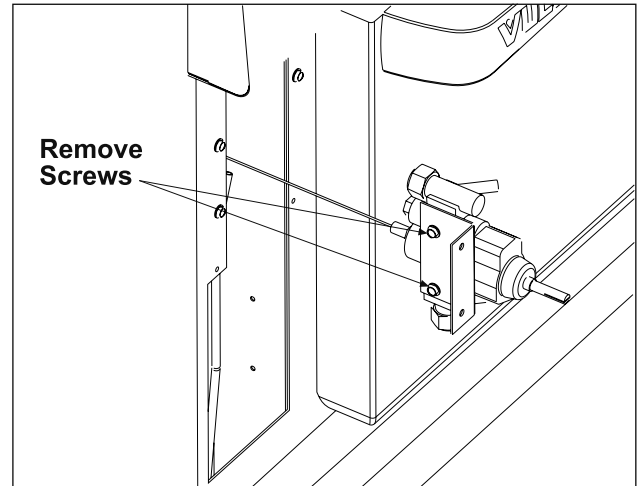

4. Open the oven door.
5. Remove capillary tube from all routing clips.

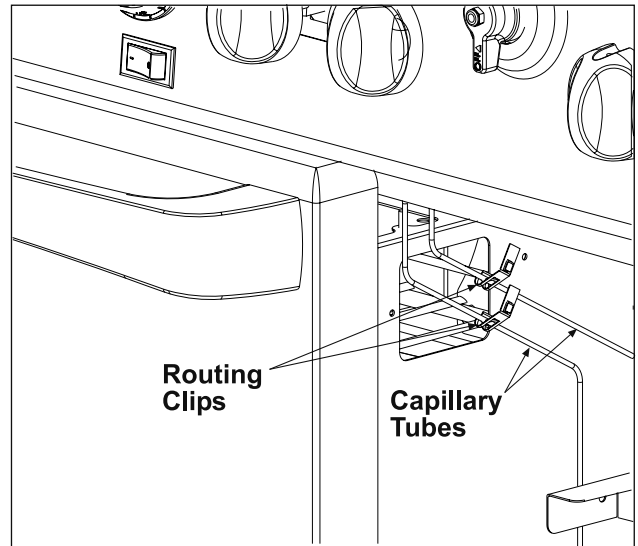

**NOTE:** When straightening the capillary tube be sure not to place kinks in tubing.

6. Slide the capillary tube out of the bracket and straighten the tube so that it can be passed through the hole in the oven sidewall.

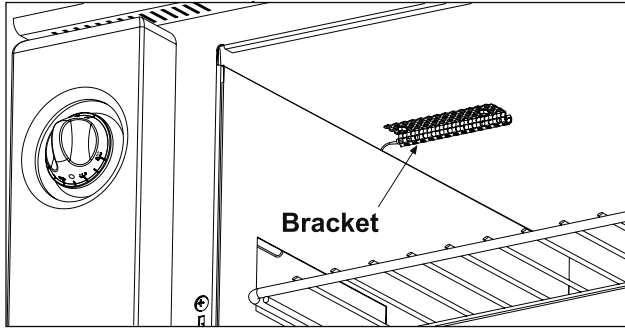

7. Carefully slide the capillary tube through the hole in the oven sidewall.
8. Disconnect the gas input to the control valve.

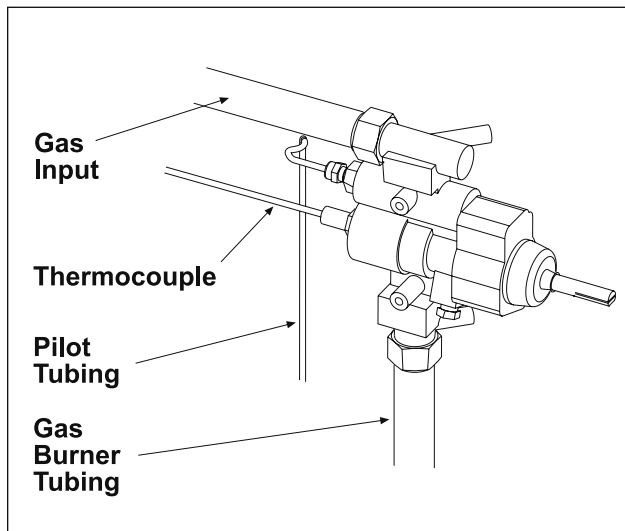

9. Disconnect the pilot tubing.
10. Disconnect the control valve burner tubing.
11. Remove the control valve assembly from the oven.
12. Reverse the procedure to install a new control valve assembly.

**NOTE:** During installation do not kink the new capillary tube when feeding it through the hole in the side of the oven cavity. Excess tubing can be loosely wrapped.

**Model 60, 260, and 481**

The control valves are located behind the oven manifold cover.

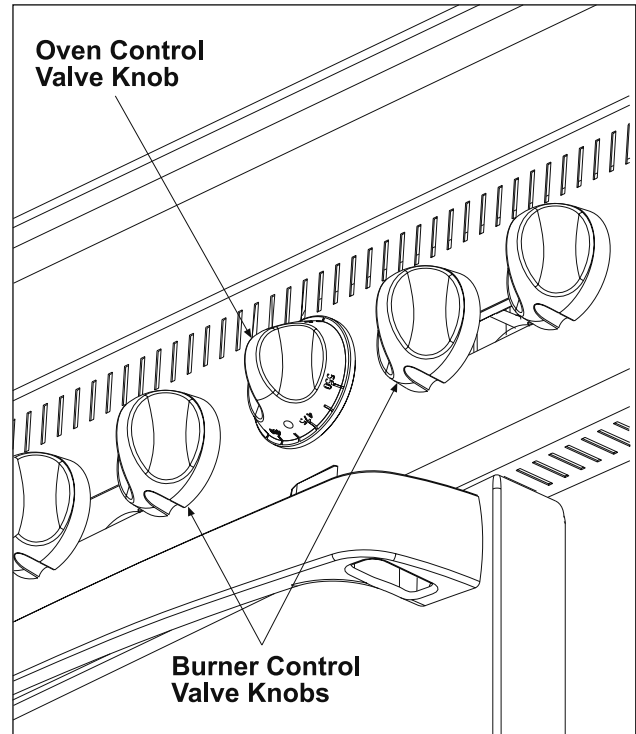

1. Remove the oven manifold cover as outlined under COVERS AND PANELS.
2. Remove top burner grates and deflector, if necessary, to access the control valve.
3. Disconnect the pilot tubing from the control valve.
4. Remove two screws securing the control valve to the manifold.

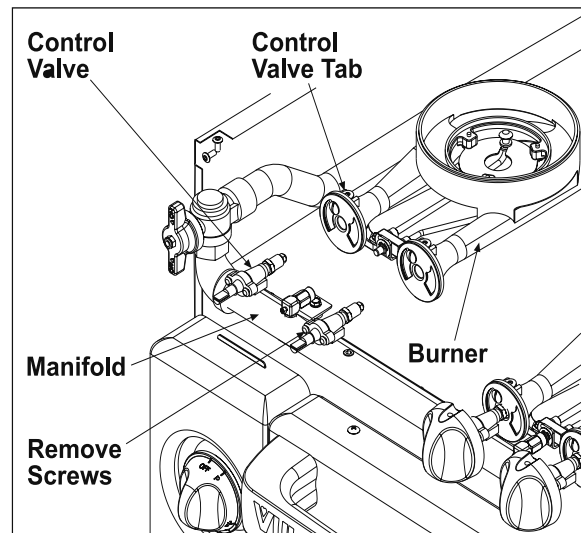

- Remove the kick plate as outlined under **COVERS AND PANELS**.

**NOTE:** Do not kink the capillary tube when straightening the tubing for removal.

- Slide the capillary tube and thermocouple out of the bracket and straighten the tube so that it can be passed through the holes in the oven liner.
- Remove the capillary tube from all routing clips.

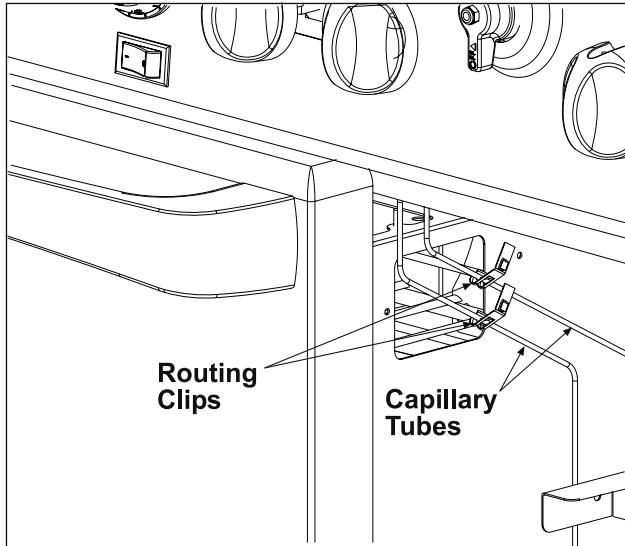

- Carefully slide the capillary tube and thermocouple through the holes in the oven.
- Remove the control valve, capillary tube, and thermocouple from the unit.
- Reverse the procedure to install a new control valve assembly.

**NOTE:** During installation do not kink the new capillary tube when feeding it through the holes in the oven. Excess tubing can be loosely wrapped.

## OVEN PILOT ASSEMBLY



**WARNING:** DISCONNECT THE ELECTRICAL POWER TO THE MACHINE AND FOLLOW LOCKOUT / TAGOUT PROCEDURES.

**WARNING:** SHUT OFF THE GAS BEFORE SERVICING THE UNIT.

**WARNING:** ALL GAS JOINTS DISTURBED DURING SERVICING MUST BE CHECKED FOR LEAKS. CHECK WITH A SOAP AND WATER SOLUTION (BUBBLES). DO NOT USE AN OPEN FLAME.

The oven pilot assembly is attached to the burner assembly behind the kick plate.

- Remove the kick plate as outlined under **COVERS AND PANELS**.
- Remove the oven rack.
- Remove the oven bottom.
- Remove the oven left and right liner.
- Remove the oven bottom heat shield.
- Remove the screws securing oven pilot assembly to the burner assembly.

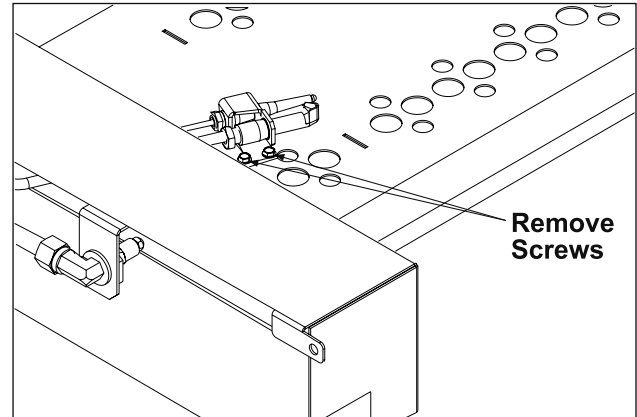

- Pull the pilot assembly out through the front of oven.
- Reverse the procedure to install the oven pilot assembly.

## OVEN BURNER ASSEMBLY



**WARNING:** DISCONNECT THE ELECTRICAL POWER TO THE MACHINE AND FOLLOW LOCKOUT / TAGOUT PROCEDURES.

**WARNING:** SHUT OFF THE GAS BEFORE SERVICING THE UNIT.

**WARNING:** ALL GAS JOINTS DISTURBED DURING SERVICING MUST BE CHECKED FOR LEAKS. CHECK WITH A SOAP AND WATER SOLUTION (BUBBLES). DO NOT USE AN OPEN FLAME.

The oven burner assembly is located behind the kick plate.

- Remove the oven pilot assembly as outlined under **OVEN PILOT ASSEMBLY**.



- Remove the two screws securing the oven burner assembly.

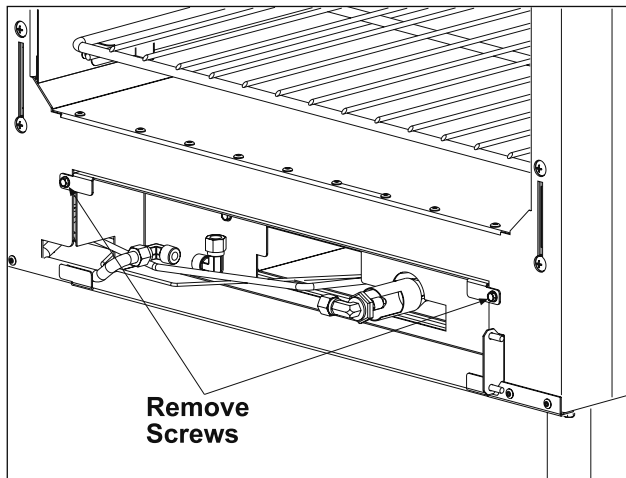

- Disconnect gas line to the burner.
- Pull the oven burner assembly out of the oven.
- Reverse the procedure to install a new oven burner assembly.

## CONVECTION OVEN CONTROL VALVE/THERMOCOUPLE PILOT



**WARNING:** DISCONNECT THE ELECTRICAL POWER TO THE MACHINE AND FOLLOW LOCKOUT / TAGOUT PROCEDURES.

**WARNING:** SHUT OFF THE GAS BEFORE SERVICING THE UNIT.

**WARNING:** ALL GAS JOINTS DISTURBED DURING SERVICING MUST BE CHECKED FOR LEAKS. CHECK WITH A SOAP AND WATER SOLUTION (BUBBLES). DO NOT USE AN OPEN FLAME.

The control valve is located behind the oven manifold cover.

- Remove the oven manifold cover as outlined under COVERS AND PANELS.
- Remove top burner grates and deflector, if necessary, to access the control valve.
- Disconnect the pilot tubing.
- Remove the two screws securing the control valve to the manifold.

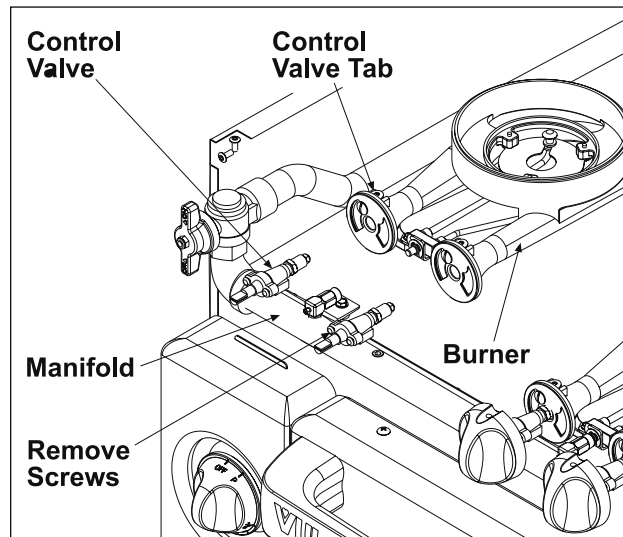

- Remove the kick plate as outlined under COVERS AND PANELS.

**NOTE:** Do not kink the capillary tube when straightening the tubing for removal.

- Slide the capillary tube and thermocouple out of the bracket and straighten the tube so that it can be passed through the holes in the oven liner.
- Remove the capillary tube from all routing clips.

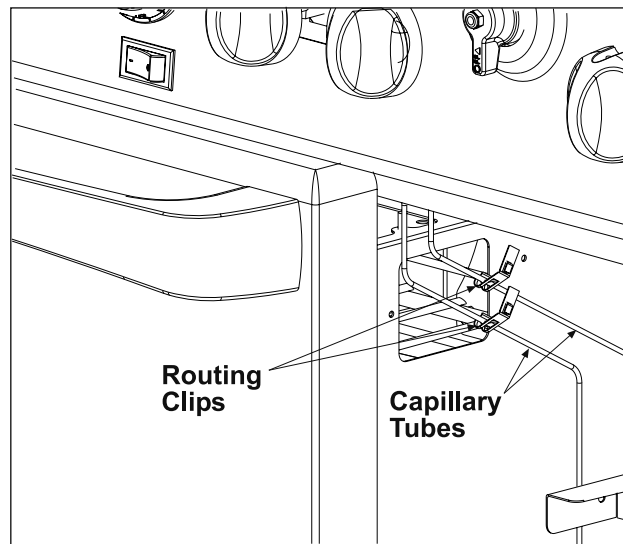

- Carefully slide the capillary tube and thermocouple through the holes in the oven.
- Remove the control valve, capillary tube and thermocouple from the unit.
- Reverse the procedure to install a new control valve assembly.

**NOTE:** During installation do not kink the new capillary tube when feeding it through the holes in the oven. Excess tubing can be loosely wrapped.

## OVEN BURNER NOZZLE AND ORIFICE



**WARNING:** DISCONNECT THE ELECTRICAL POWER TO THE MACHINE AND FOLLOW LOCKOUT / TAGOUT PROCEDURES.

**WARNING:** SHUT OFF THE GAS BEFORE SERVICING THE UNIT.

**WARNING:** ALL GAS JOINTS DISTURBED DURING SERVICING MUST BE CHECKED FOR LEAKS. CHECK WITH A SOAP AND WATER SOLUTION (BUBBLES). DO NOT USE AN OPEN FLAME.

The oven burner nozzle is mounted between the oven gas supply tubing and the u-burner assembly.

1. Turn off the burners.
2. Disconnect the unit from gas flow and allow to cool completely.
3. Remove the kick plate as outlined under COVERS AND PANELS.
4. Remove the burner nozzle.
5. Check for blockage or damage.
6. Reverse the procedure to install the burner nozzle.

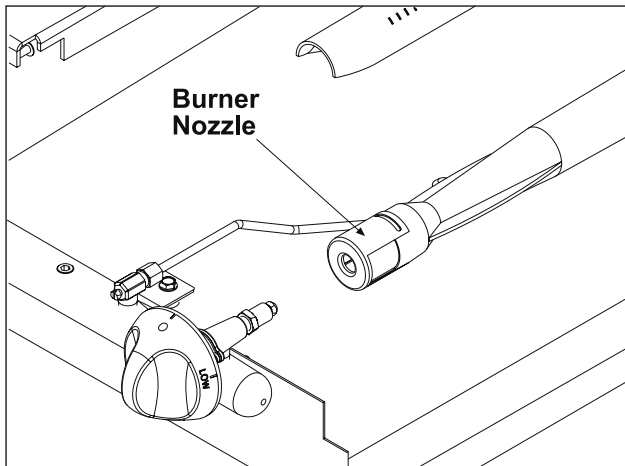

## PILOT VALVE AND QUICK DISCONNECT VALVE



**WARNING:** DISCONNECT THE ELECTRICAL POWER TO THE MACHINE AND FOLLOW LOCKOUT / TAGOUT PROCEDURES.

**WARNING:** SHUT OFF THE GAS BEFORE SERVICING THE UNIT.

**WARNING:** ALL GAS JOINTS DISTURBED DURING SERVICING MUST BE CHECKED FOR LEAKS. CHECK WITH A SOAP AND WATER SOLUTION (BUBBLES). DO NOT USE AN OPEN FLAME.

The pilot valve for the griddle burners is mounted on the gas supply manifold located behind the griddle control panel.

1. Remove the oven manifold cover as outlined under COVERS AND PANELS.
2. Remove top burner grates and deflector, if necessary, to access the pilot valve.
3. Disconnect the pilot tubing from the holder.

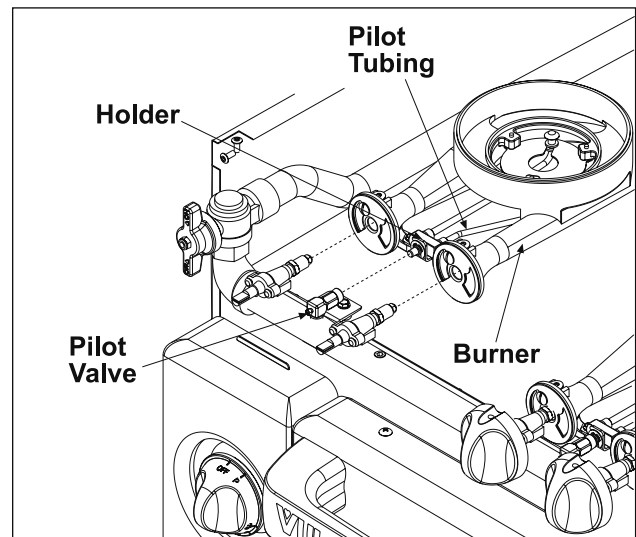

4. Disconnect the holder from the pilot valve.
5. Remove the pilot valve from the manifold.
6. Reverse the procedure to install a new pilot valve.

## TOP SECTION BURNER CONTROL VALVE



**WARNING:** DISCONNECT THE ELECTRICAL POWER TO THE MACHINE AND FOLLOW LOCKOUT / TAGOUT PROCEDURES.

**WARNING:** SHUT OFF THE GAS BEFORE SERVICING THE UNIT.

**WARNING:** ALL GAS JOINTS DISTURBED DURING SERVICING MUST BE CHECKED FOR LEAKS. CHECK WITH A SOAP AND WATER SOLUTION (BUBBLES). DO NOT USE AN OPEN FLAME.

1. Remove the oven manifold cover as outlined under COVERS AND PANELS.
2. Allow the range to cool completely.
3. Remove the burner grates and deflectors, if necessary.
4. Remove the griddle plate assembly, if necessary.
5. Remove the burner mounting screws.
6. Carefully move the burner assembly away from the burner control valve.
7. Remove the burner control valve from the manifold.
8. Clean the manifold of any thread sealant.
9. Inspect the control valve for wear and damage, replace as necessary.
10. Reverse the procedure to install a new burner control valve.

**NOTE:** Apply a light coat of thread sealant to the control valve threads before installing the burner control valve in the manifold.

## SWITCH REPLACEMENT



**WARNING:** DISCONNECT THE ELECTRICAL POWER TO THE MACHINE AND FOLLOW LOCKOUT / TAGOUT PROCEDURES.

1. Remove the oven manifold cover as outlined under COVERS AND PANELS.
2. Allow the range to cool completely.

3. Disconnect wiring from the switch.

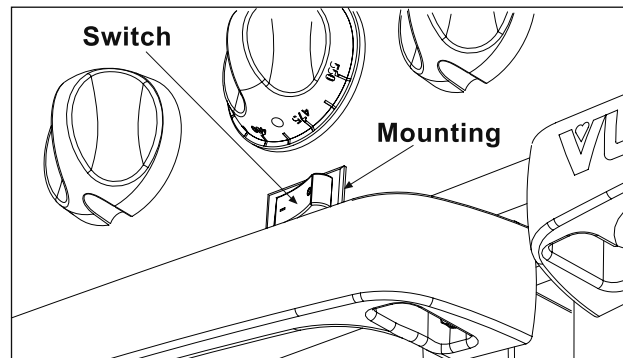

4. Remove the switch from mounting.
5. Reverse the procedure to install the replacement switch.

## MOTOR REPLACEMENT



**WARNING:** DISCONNECT THE ELECTRICAL POWER TO THE MACHINE AND FOLLOW LOCKOUT / TAGOUT PROCEDURES.

**NOTE:** A centrifugal switch is mounted inside the motor assembly. If electrical voltage is available to the motor, the motor and switch must be replaced.

1. Remove cover from the motor junction box.

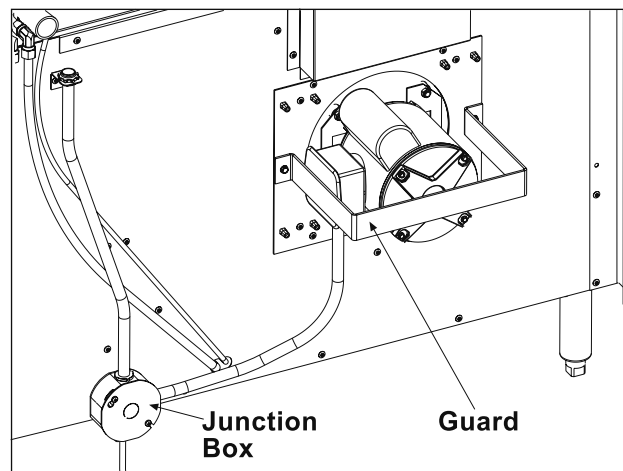

2. Disconnect motor wiring at the junction box.
3. If necessary, remove the motor guard.

4. Inside the oven remove the hex head bolts and spacers attaching the motor grate to the motor mounting plate and remove the motor grate.

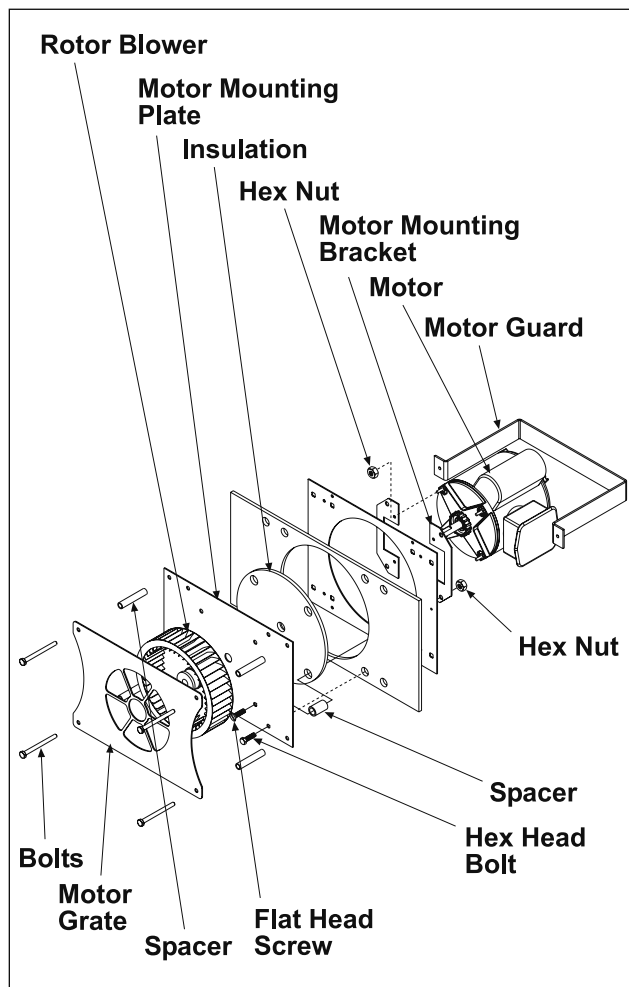

5. Remove the motor and rotor blower assembly from inside the oven.
6. Remove the fan from the motor.
7. Remove motor from motor mounting plate.
8. Reverse the procedure to install a new motor.

## CONVECTION OVEN SOLENOID



**WARNING:** DISCONNECT THE ELECTRICAL POWER TO THE MACHINE AND FOLLOW LOCKOUT / TAGOUT PROCEDURES.

**WARNING:** SHUT OFF THE GAS BEFORE SERVICING THE UNIT.

**WARNING:** ALL GAS JOINTS DISTURBED DURING SERVICING MUST BE CHECKED FOR LEAKS. CHECK WITH A SOAP AND WATER SOLUTION (BUBBLES). DO NOT USE AN OPEN FLAME.

1. Disconnect gas supply to the range.
2. Disconnect the solenoid electrical connectors.

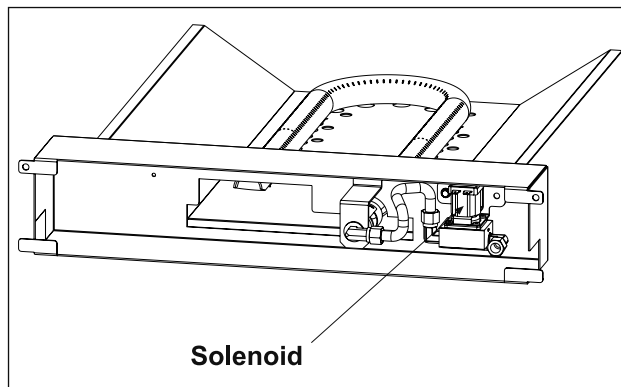

3. Disconnect gas supply lines from both sides of the solenoid.

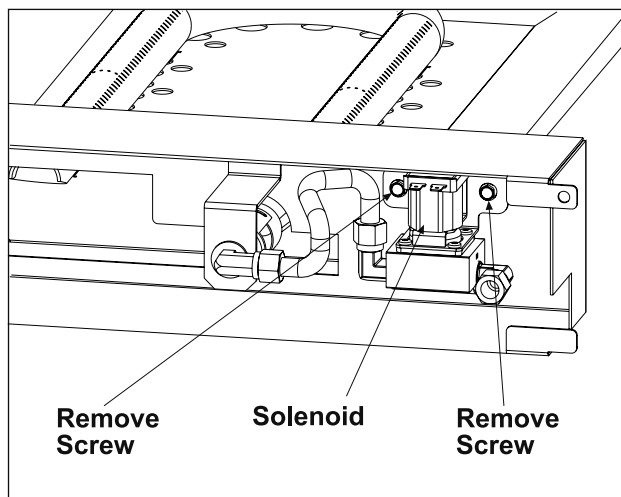

4. Remove solenoid mounting screws and solenoid.
5. Reverse the procedure to install the replacement solenoid.

# SERVICE PROCEDURES AND ADJUSTMENTS

**WARNING:** CERTAIN PROCEDURES IN THIS SECTION REQUIRE ELECTRICAL TEST OR MEASUREMENTS WHILE POWER IS APPLIED TO THE MACHINE. EXERCISE EXTREME CAUTION AT ALL TIMES. IF TEST POINTS ARE NOT EASILY ACCESSIBLE, DISCONNECT POWER AND FOLLOW LOCKOUT / TAGOUT PROCEDURES, ATTACH TEST EQUIPMENT AND REAPPLY POWER TO TEST.

## PILOT FLAME HEIGHT

### Top Burners

To adjust the pilot flame height of the top burners, locate the pilot adjustment screws found on the front manifold pipe. It is not necessary to remove the manifold cover as adjustment access holes have been provided in the panel.

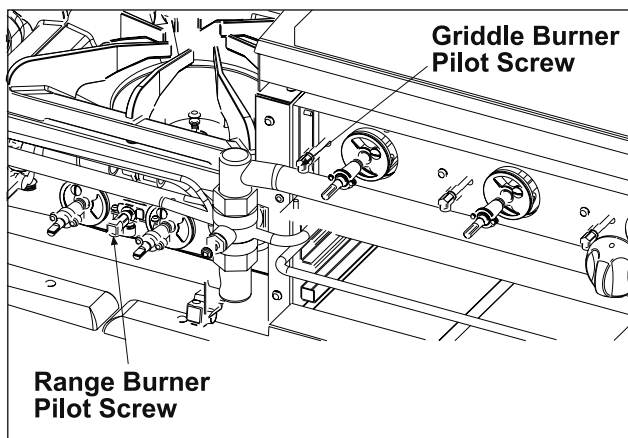

1. Locate the pilot adjustment screw located behind the adjustment access hole in the panel.
2. Rotate the screw clockwise to decrease and counterclockwise to increase the flame height.

### Broiler/Griddle

To adjust pilot flame height of broiler/griddle, locate the pilot adjustment screws found on the broiler/griddle manifold pipe. It is not necessary to remove the manifold cover, as adjustment access holes have been provided in the panel.

1. Locate the pilot adjustment screw located behind the adjustment access hole in the panel.
2. Rotate the screw clockwise to decrease and counterclockwise to increase the flame height.

## AIR SHUTTER ADJUSTMENT

The efficiency of the oven depends on a delicate balance between the air supply and the volume of gas. Whenever this balance is disturbed, poor operating characteristics and excessive gas consumption will occur. An air shutter on the front of the oven burner controls the gas mixer balance. A yellow

streaming flame on the burner is an indication of insufficient air. To correct this condition, rotate the air shutter open until the burner flame begins to lift from the burner, then close the shutter slightly.

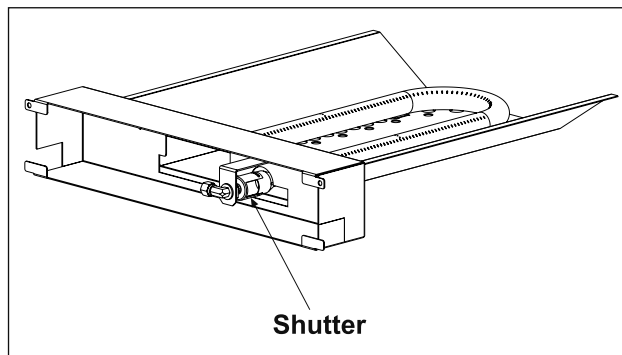

## OVEN BURNER ADJUSTMENT

All Endurance Range series units equipped with a pressure regulator and fixed orifices have been adjusted at the factory and should require no further adjustments. However, the efficiency of the range depends on a delicate balance between the air supply and the volume of gas. Whenever this balance is disturbed, poor operating characteristics and excessive gas consumption will occur. An air shutter on the front of the oven burner controls the gas mixer balance.

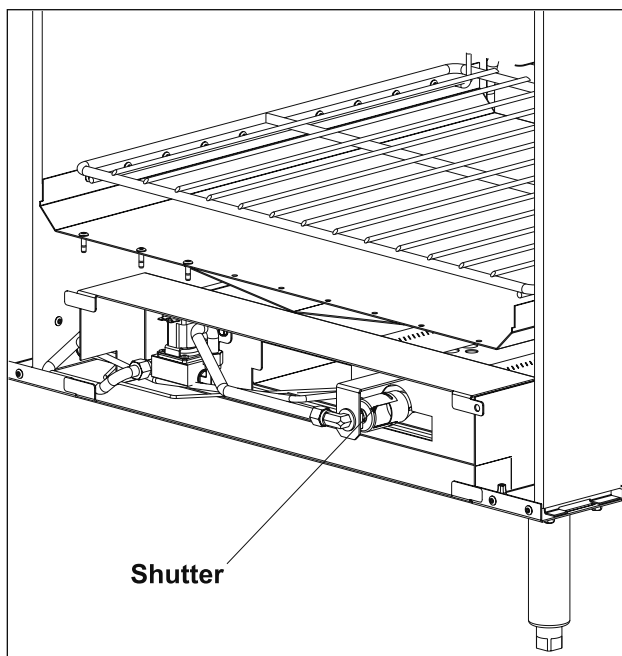

A yellow streaming flame on the burner is an indication of insufficient air. To correct this condition, open the air shutter until the burner flame begins to lift from the burner, then close the shutter slightly and lock into place.

## REGULATOR CHECK

A gas regulator is mounted between the gas service outlet and the appliance.

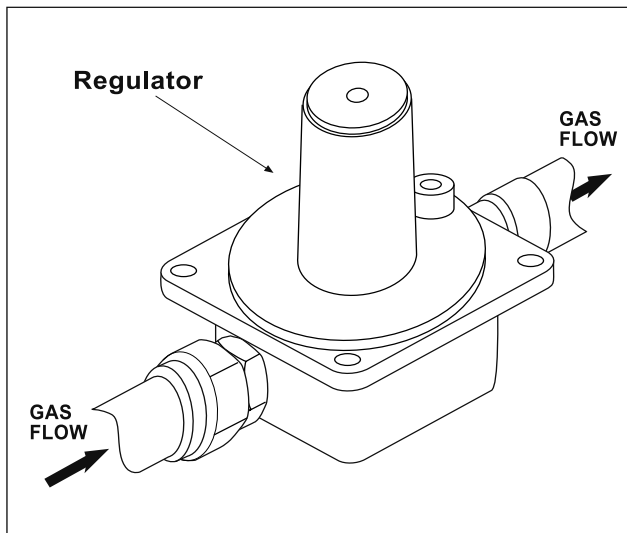

When servicing the equipment for possible gas pressure problems, visually check that a regulator is installed horizontal with the gas flow arrow pointing in the direction of gas flow.

1. Turn on the range top burners.
2. Observe the burner flames.

A leak (vent) limiting device is installed in each regulator to limit gas leakage if the regulator ruptures. Do not obstruct the leak limiter (vent). Obstruction may cause regulator malfunction or failure.

3. Connect the manometer to the pressure tap provided between the regulator and range supply piping.
4. Turn on two top burners and note manometer reading. The reading should be 7.0" W.C. for natural gas units and 11.0" W.C. for propane gas units. If readings are lower, check incoming gas line pressure.

**NOTE:** The line pressure should never drop below 5.0" W.C. for natural gas or 11.0" W.C. for propane gas.

The incoming line pressure must be correct for proper range operation. If line pressure is incorrect have the gas supply source checked and adjusted. If line pressure is correct adjust the regulator as follows.

5. With regulator reading 7.0" W.C. (natural gas) or 11.0" W.C. (propane gas), turn on two top burners.
6. Check regulator pressure reading. The reading should be steady  $\pm 0.10$ ". If fluctuation in excess of  $\pm 0.10$ " occurs replace the regulator.

**NOTE:** If pressure readings climb to limits shown in step 4 with the burners OFF, check the leak (vent) limit device for obstruction. Check the regulator for leaks at the leak limiter vent. If vent is leaking, replace the regulator.

## REGULATOR ADJUSTMENT

**NOTE:** Before adjusting regulator, check incoming gas line pressure. Incoming pressure must be 7.0" W.C. for natural gas and 11.0" W.C. for propane gas. If incoming pressure is not correct have the gas source checked and adjusted as necessary. Make sure the regulator is mounted in the horizontal position with the arrow pointing in the direction of gas flow.

1. Connect manometer to the pressure tap provided on the range gas piping between the regulator and range.
2. Check manometer reading. The reading should be 7.0" W.C. for natural gas and 11.0" W.C. for propane gas.
3. If incoming line pressure is correct, adjust the regulator. Remove the regulator closing nut.

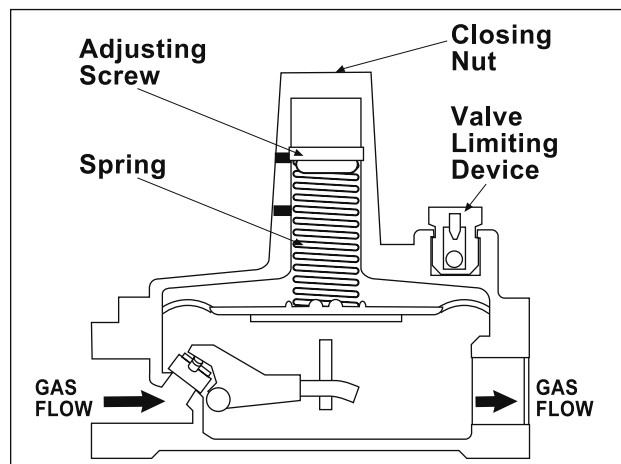

4. Insert a flat edge screwdriver through the top of the regulator. Turn the adjusting screw clockwise to increase pressure and counterclockwise to decrease pressure.
5. While watching the manometer, turn the adjusting screw for proper regulator outlet pressure.
6. Install the regulator closing nut.

## OVEN BURNER NOZZLE AND ORIFICE CHECK

The oven burner nozzle is mounted between the oven gas supply tubing and the u-burner assembly. If burner operation seems poor and other systems have been checked, remove the burner nozzle and check for blockage or damage.

1. Turn off burners and oven.
2. Disconnect unit from gas flow and allow to cool completely.
3. Remove the kick plate as outlined under COVERS AND PANELS.
4. Remove the burner nozzle.
5. Check for blockage or damage.

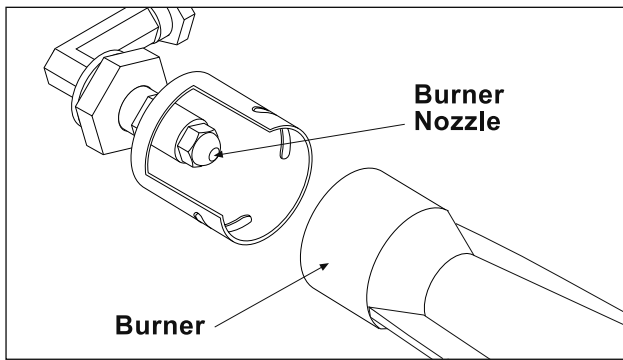

**NOTE:** Nozzle blockage can be cleaned or nozzle replaced. Use high-pressure water and tip cleaner to clean the nozzle. Replace the nozzle if damaged or blockage cannot be removed. Check nozzle for correct orifice size and BTU rating. Use a flow meter (available from Vulcan-Hart Service Parts Depots, Part #495) to check BTU rate. See flow meter instructions for proper installation and use.

## CONVECTION OVEN MOTOR AND DOOR SWITCH CHECK

A control switch mounted just below the convection oven control valve controls the motor.

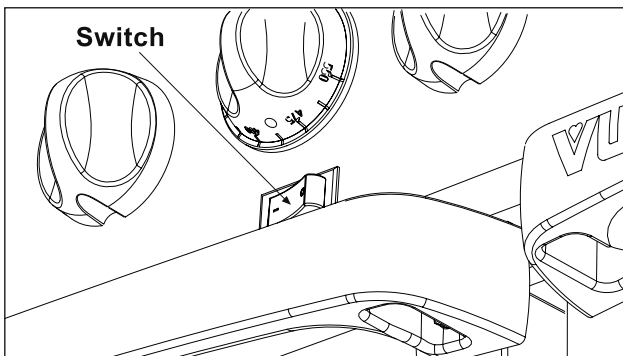

1. Shut off the yellow gas supply knob.
2. Allow the range to cool completely.
3. Disconnect electrical power to the range.
4. Loosen the screws in the sides of the control valve knobs and remove the knobs.
5. Remove the control panel mounting screws and the control panel cover.
6. Activate the power switch (see illustration) several times and check for wear, damage, and loose wiring connections. Repair connections as necessary.
7. Connect electrical power to the range.
8. Check power connections for power range (220 volts AC or 120 volts AC).
9. With the power switch in the ON position, check for voltage at both switch connections. If no voltage is available, check power source and breakers. If voltage is available at switch input only, replace the switch.
10. If voltage is available at power switch connections, remove kick plate as outlined under COVERS AND PANELS.
11. Locate the door switch.
12. Disconnect electrical power to the range.
13. Inspect the door switch for wear, damage, and loose or broken connections. Repair as necessary.
14. Place multimeter in the continuity range. Check for continuity between the switch connections in the open and closed position. If continuity is not available replace the switch.
15. If continuity is available with switch closed, connect electrical power to the range.
16. Place multimeter in appropriate AC range (220 volts AC or 120 volts AC).
17. Place the power switch in the ON position.
18. Check for voltage at the door switch input connection. If voltage is not available, disconnect electrical power and check continuity between the motor switch and door switch. Repair wiring as necessary.
19. If input voltage is available, carefully close the switch (close the door) and check for voltage at the switch output connection. If voltage is not available, replace the switch.
20. If output voltage is available, disconnect electrical power to the range.
21. Remove the cover from the motor electrical junction box located on the back of the range.

22. With the motor switch and door switch in the closed position, check for voltage at the motor input connection. If voltage is available, replace the motor. If voltage is not available, disconnect electrical power from the range and check continuity between the door switch output connection and motor input connection. Repair as necessary.

## CONVECTION OVEN SOLENOID CHECK

The convection oven solenoid is mounted between the gas supply and convection oven burner assembly.

1. Remove the kick plate as outlined under **COVERS AND PANELS**.
2. Locate the convection oven solenoid.

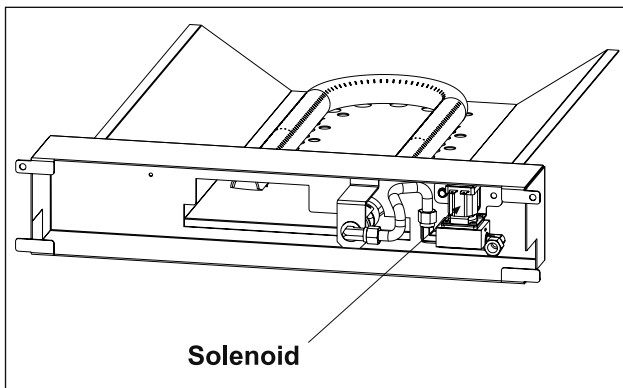

3. Place the convection oven power switch in the ON position. An audible click should occur when the switch is activated. If the solenoid does not cycle, check for proper voltage and ground at the solenoid.
4. Place the multimeter in the appropriate AC range (220 volts AC or 120 volts AC). Check for voltage at the solenoid. If voltage is not available, check continuity between the power switch and solenoid.
5. If voltage is available, shut off electrical power to the range. Place the multimeter in the continuity range. Check for continuity between the solenoid ground connection and a ground. If continuity is not available, check and repair ground connections.
6. If continuity is available, remove the solenoid and check for solenoid orifice obstruction. See the procedure **REMOVAL OF CONVECTION OVEN SOLENOID** for solenoid removal instructions.
7. Reinstall the solenoid.



---

**- THIS PAGE INTENTIONALLY LEFT BLANK -**

# ELECTRICAL OPERATION

## COMPONENT FUNCTION

<b>Power Cord</b> .....	Connects range to power source.
<b>Solenoid Valve</b> .....	The solenoid is a normally closed valve. The solenoid opens when electrical voltage flows to the solenoid coil. The coil is grounded on one side and energized with voltage on the other side. When voltage flows a magnetic field is created drawing on a spring-loaded plunger. When activated the plunger opens allowing gas to flow to the burner assembly.
<b>Door Switch</b> .....	Opens circuit to convection motor and solenoid when oven door is opened.
<b>Single Phase Convection Oven Motor</b> .....	The convection oven motor circulates overheated air. The motor electrical circuit is routed through door switches. The door closes the switch and allows voltage to flow from the door switch to the motor. The motor should operate with the door closed and shut off when the door is opened.
<b>Junction Box</b> .....	Connection point for electrical wires.

## SEQUENCE OF OPERATION

Refer to schematic diagram.

Initial Conditions

1. Conditions.
  - A. Power switch off.
  - B. Oven door open.
2. Turn power switch on.
  - A. Power applied to one side of convection oven motor and one side of solenoid.
  - B. Power applied to common terminal on door switch.
3. Door switch closed.
  - A. Power applied to other side of convection oven motor and motor operates.
  - B. Power applied to other side of solenoid. Solenoid operates and opens gas flow to burner.
4. Door opened.
  - A. Power removed from solenoid cutting off gas flow.
  - B. Power is removed from convection oven motor causing motor to stop.

**SCHEMATIC DIAGRAM**

**Double Oven 120 Volt Endurance Convection Range**

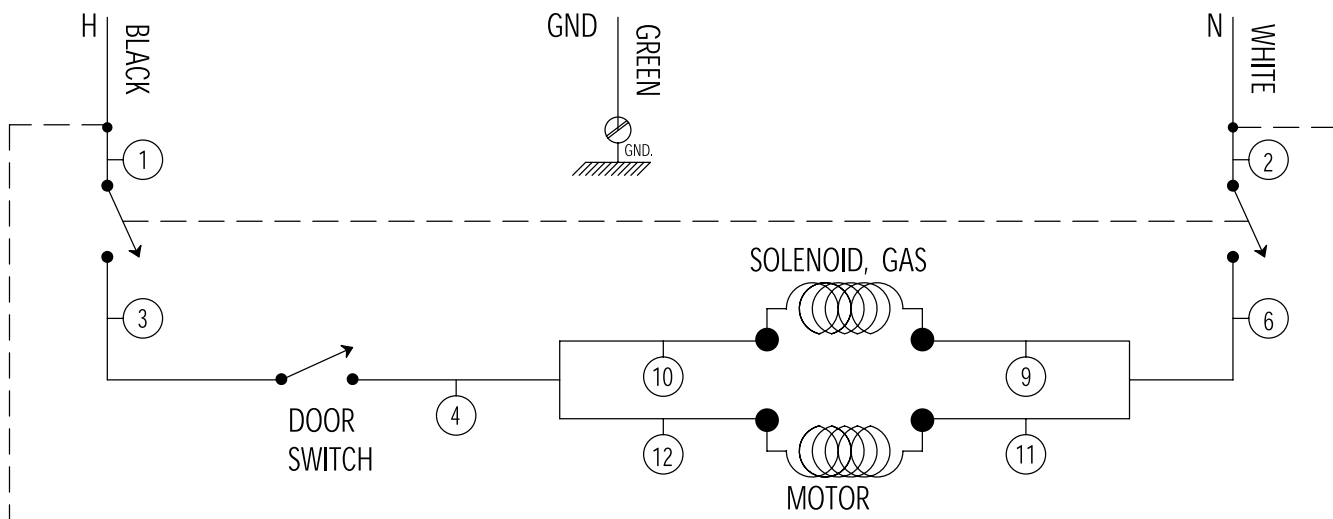

LEFT SIDE & SINGLE OVEN SHOWN ABOVE AS 497523-1

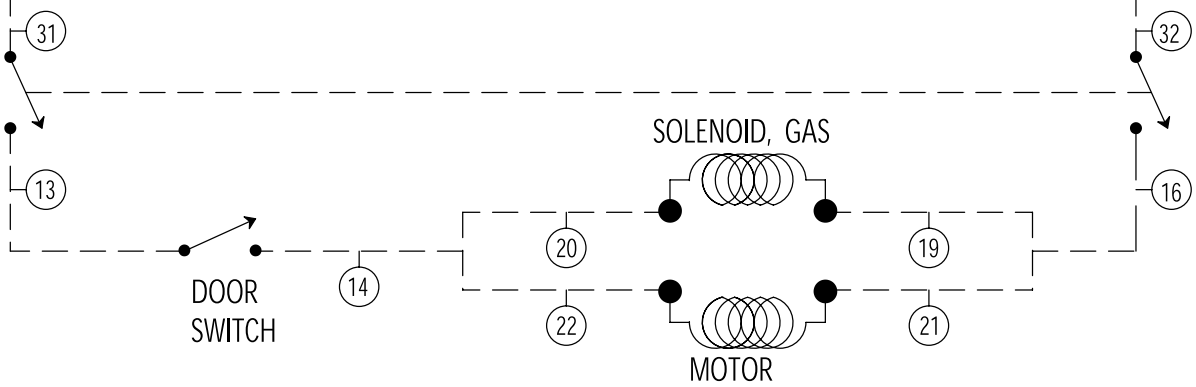

60" UNITS REQUIRE FULL DECAL 497523-2

# WIRING DIAGRAMS

## Double Oven 120 Volt Endurance Convection Range (Drawing 1 of 2)

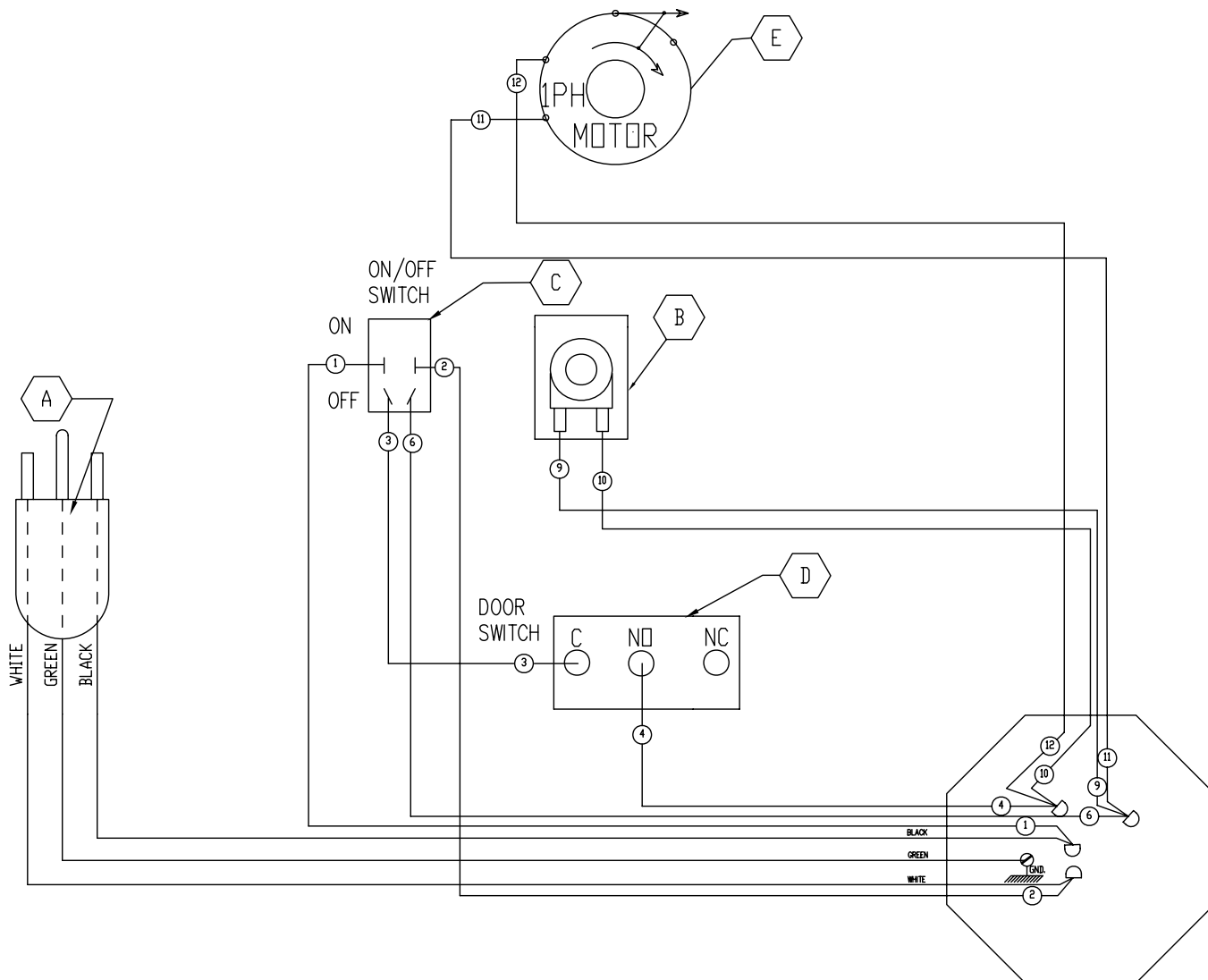

SEE SCHEMATIC DECAL 497523-1

2	E	MOTOR 1/6 HP 120 V.	--
2	D	DOOR SWITCH	--
2	C	ROCKER SWITCH	--
2	B	SOLENOID	--
1	A	POWER CORD	--
REQ.	PT.	DESCRIPTION	FIN.
<b>WIRING INFORMATION</b>			
FOR UNITS LISTED			
WIRING DIAGRAM DOUBLE OVEN 120 VOLT			
ENDURANCE CONVECTION RANGE			
SCALE NONE			
SHEET 1 OF 2		D 497522	REV A2

Double Oven 120 Volt Endurance Convection Range (Drawing 2 of 2)

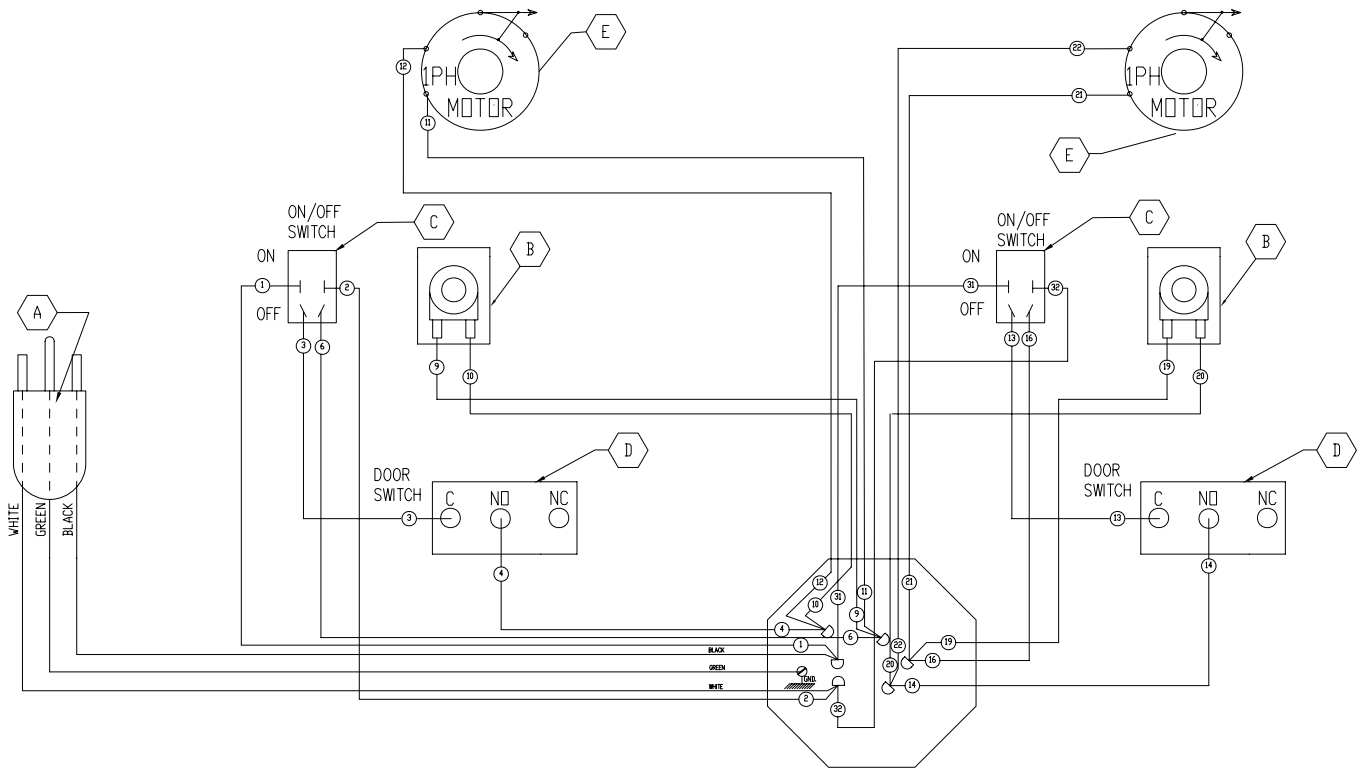

SEE SCHEMATIC DECAL 497523-2

2	E MOTOR 1/6 HP 120 V.	--	
2	D DOOR SWITCH	--	
2	C ROCKER SWITCH	--	
2	B SOLENOID	--	
1	A POWER CORD	--	
REQ.	IT.	DESCRIPTION	FIN.
<b>WIRING INFORMATION</b>			
<b>FOR UNITS LISTED</b>			
WIRING DIAGRAM DOUBLE OVEN 120 VOLT ENDURANCE CONVECTION RANGE			
SCALE NONE			
SHEET 2 OF 2		D 497522	REV A 2

# TROUBLESHOOTING

SYMPTOM	POSSIBLE CAUSES
Convection oven motor does not operate.	<ol style="list-style-type: none"><li data-bbox="732 254 1052 281">1. Oven door not closed.</li><li data-bbox="732 296 1117 323">2. Power switch not turned on.</li><li data-bbox="732 338 1078 365">3. Faulty convection motor.</li></ol>
Convection oven motor operates but no gas flow to oven burner.	Faulty solenoid.
Convection oven motor noisy.	<ol style="list-style-type: none"><li data-bbox="732 464 1052 491">1. Motor mounting loose.</li><li data-bbox="732 506 1094 533">2. Fan loose on motor shaft.</li></ol>
Pilots do not remain lit.	Low gas pressure. Check incoming gas line and check regulator.
Burner flame too yellow.	<ol style="list-style-type: none"><li data-bbox="732 627 1458 655">1. Check for correct orifice and for correct shutter adjustment.</li><li data-bbox="732 669 1133 697">2. Check for blockage at orifice.</li></ol>

# CONDENSED SPARE PARTS LIST

## ENDURANCE SERIES GAS RANGE

PART NO.	DESCRIPTION
411496-B1	Switch
411496-F1	Door Switch (Single Oven)
411496-F7	Door Switch (Double Oven)
497240-1	Griddle Valve
497246-1	Griddle Knob
404076	Burner Valve
428300-1	Burner Valve Knob
428904-1	Pilot Quick Disconnect Valve
404193-1	Broiler Pilot Valve
404193-2	Griddle Pilot Valve
497175-1	Solenoid Valve (36, 48 & RH of 60 & 260)
497175-2	Solenoid Valve (LH of 60 & 260)
412788-4	T/Couple (Single Oven)
428305-1	T/Couple (Double Oven)
419730-1	Motor
415780-2	Air Rotor
408279-26	Regulator 3/4 NPT (Single Oven) Nat. Gas
408279-27	Regulator 1 NPT (Single Oven) Nat. Gas
408279-21	Regulator 3/4 NPT (Single Oven) LP Gas
428807-1	Thermostat, Oven Control Valve (Single Oven)
428806-1	Thermostat, Oven Control Valve (Double Oven)
428617-1	Oven Thermostat Knob