

10 Sunnen Drive
St. Louis, MO 63143
telephone: 314-678-6336
fax: 314-781-2714
www.wellsbloomfield.com

OWNERS MANUAL
for

E. B. C.™ *Electronic Brew Control*™



**LO-PROFILE
E.B.C.™ AIRPOT
BREWERS**

**MODELS
1882
and
1882CA**

**Includes:
Installation
Use & Care
Servicing
Instructions**

*Model 1882
with optional
7874 Airpot*

E.B.C.™ brewers are protected under
U. S. Patent # 5, 704,275
Other U. S. and Canadian patents.

WARRANTY STATEMENT

All electrical equipment manufactured by WELLS BLOOMFIELD, LLC is warranted against defects in materials and workmanship for a period of one year from the date of original installation or eighteen (18) months from the date of shipment from our factory, whichever comes first, and is for the benefit of the original purchaser, except that:

- a. airpots carry a 30 day parts warranty only.
- b. dispensers; i.e., tea and coffee carry a 90 days parts warranty only, excludes decanters.

THE FOREGOING OBLIGATION IS EXPRESSLY GIVEN IN LIEU OF ANY OTHER WARRANTIES, EXPRESSED OR IMPLIED, INCLUDING ANY IMPLIED WARRANTY OF MERCHANTABILITY OR FITNESS FOR A PARTICULAR PURPOSE, WHICH ARE HEREBY EXCLUDED.

WELLS BLOOMFIELD, LLC SHALL NOT BE LIABLE FOR INDIRECT, INCIDENTAL OR CONSEQUENTIAL DAMAGES OR LOSSES FROM ANY CAUSE WHATSOEVER.

This warranty is void if it is determined that upon inspection by an Authorized Service Agency that the equipment has been modified, misused, misapplied, improperly installed, or damaged in transit or by fire, flood or act of God.

It also does not apply if the serial nameplate has been removed or unauthorized service personnel perform service. The prices charged by Bloomfield Industries for its products are based upon the limitations in this warranty. Seller's obligation under this warranty is limited to the repair of defects without charge by a Bloomfield Authorized Service Agency or one of its sub-agencies. This service will be provided on customer's premises for non-portable models. Portable models (a device with a cord and plug) must be taken or shipped to the closest Authorized Service Agency, transportation charges prepaid, for services.

In addition to restrictions contained in this warranty, specific limitations are shown below (Additional Warranty Exclusions). Bloomfield Industries Authorized Service Agencies are located in principal cities.

This warranty is valid in the United States and void elsewhere. Please consult your classified telephone directory or your food service equipment dealer; or, for information and other details concerning warranty, write to:

Service Parts Department
Wells Bloomfield, LLC

10 Sunnen Drive, St. Louis, MO 63143

Phone: (314) 678-6336... Fax: (314) 781-2714

SERVICE POLICY AND PROCEDURE GUIDE ADDITIONAL WARRANTY EXCLUSIONS

1. Resetting of safety thermostats, circuit breakers, overload protectors, or fuse replacements unless warranted conditions are the cause.
2. All problems due to operation at voltages other than specified on equipment nameplates; conversion to correct voltage must be the customer's responsibility.
3. All problems due to electrical connections not made in accordance with electrical code requirements and wiring diagrams supplied with the equipment.
4. Replacement of items subject to normal wear, to include such items as knobs and light bulbs. Normal maintenance functions including adjustment of thermostats, microswitches, and replacement of fuses and indicating lights are not covered under warranty.
5. All problems due to inadequate water supply, such as fluctuating, or high or low water pressure.
6. All problems due to mineral/calcium deposits, or contamination from chlorides/chlorines. De-liming is considered a preventative maintenance function and is not covered by warranty.
7. Full use, care and maintenance instructions are supplied with each machine. Those miscellaneous adjustments noted are customer responsibility. Proper attention will prolong the life of the machine.
8. Travel mileage is limited to sixty (60) miles from an authorized Service Agency or one of its sub-agencies.
9. All labor shall be performed during normal working hours. Overtime premium shall be charged to the customer.
10. All genuine Bloomfield replacement parts are warranted for ninety (90) days from date of purchase on non-warranted equipment. **Any use of non-genuine Bloomfield parts completely voids any warranty.**
11. Installation, labor and job check-out are not considered warranty.
12. Charges incurred by delays, waiting time or operating restrictions that hinder the service technicians ability to perform services are not covered by warranty. This includes institutional and correctional facilities.

SHIPPING DAMAGE CLAIMS PROCEDURE

NOTE: For your protection, please note that equipment in this shipment was carefully inspected and packaged by skilled personnel before leaving the factory. Upon acceptance of this shipment, the transportation company assumes full responsibility for its safe delivery.

IF SHIPMENT ARRIVES DAMAGED:

1. **VISIBLE LOSS OR DAMAGE:** Be certain that any visible loss or damage is noted on the freight bill or express receipt, and that the note of loss or damage is signed by the delivery person.
2. **FILE CLAIM FOR DAMAGE IMMEDIATELY:** Regardless of the extent of the damage.

3. **CONCEALED LOSS OR DAMAGE:** if damage is unnoticed until the merchandise is unpacked, notify the transportation company or carrier immediately, and file "CONCEALED DAMAGE" claim with them. This must be done within fifteen (15) days from the date the delivery was made to you. Be sure to retain the container for inspection.

Wells Bloomfield cannot assume liability for damage or loss incurred in transit. We will, however, at your request, supply you with the necessary documents to support your claim.

TABLE OF CONTENTS

WARRANTY STATEMENT	xi	Thank You for purchasing this Bloomfield Industries appliance.
SPECIFICATIONS	1	
FEATURES & OPERATING CONTROLS	2	
PRECAUTIONS & GENERAL INFORMATION	3	Proper installation, professional operation and consistent
AGENCY LISTING INFORMATION	3	
INSTALLATION INSTRUCTIONS	4	maintenance of this appliance will ensure that it gives you the very best performance and a long, economical service life.
OPERATION	6	
BREWING COFFEE	8	
CLEANING INSTRUCTIONS	9	
TROUBLESHOOTING SUGGESTIONS	10	This manual contains the information needed to properly install this appliance, and to use, care for and maintain or repair the appliance in a manner which will ensure its optimum performance.
SERVICING INSTRUCTIONS	11	
Deliming Instructions	16	
EXPLODED VIEW & PARTS LIST	18	
WIRING DIAGRAMS	21	

SPECIFICATIONS

Model	Style	Volts	Watts	Amps	Power Supply Cord
1882	Airpot	120V	1800	15.0	NEMA 5-15P
1882CA			1500	12.0	

 CA = Canadian Standards

APPLICABILITY

This manual applies to the following Bloomfield Industries E. B. C. ® products:

1882 1882CA

FEATURES AND OPERATING CONTROLS

AIRPOT BREWER

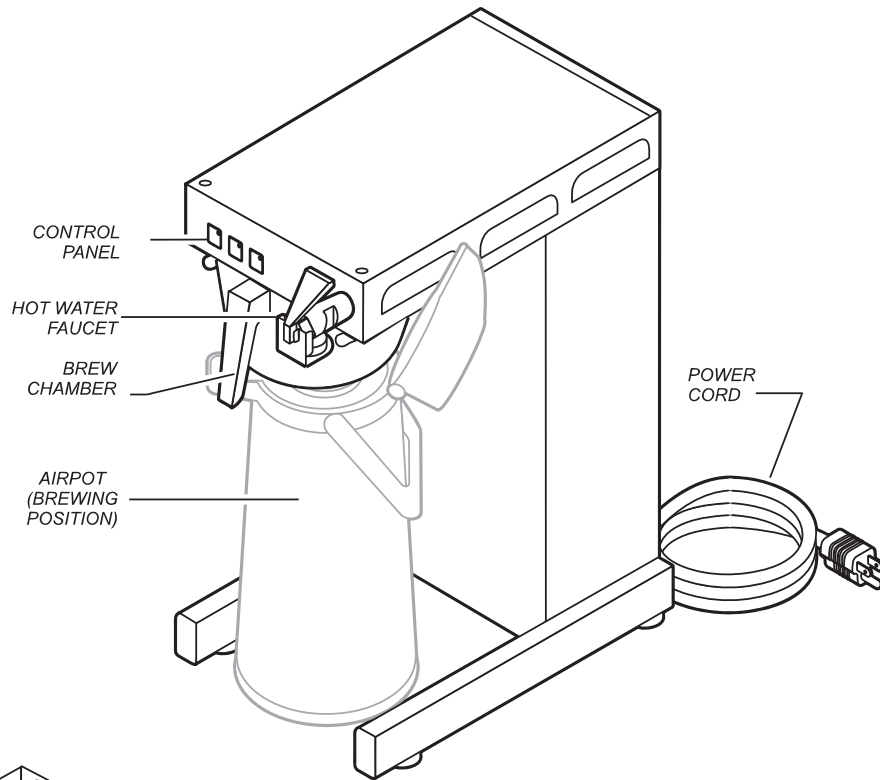

BREW HEAD (BREW CHAMBER REMOVED)

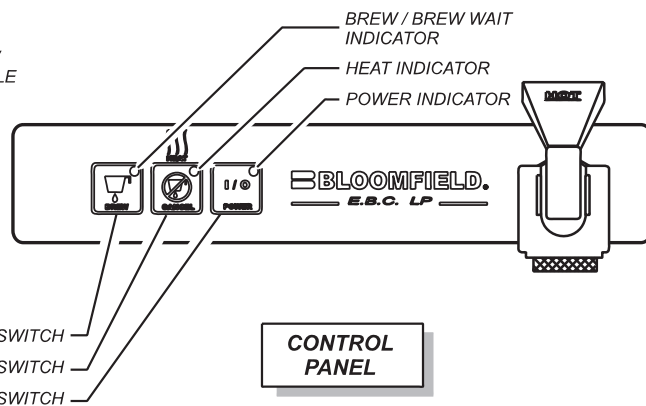
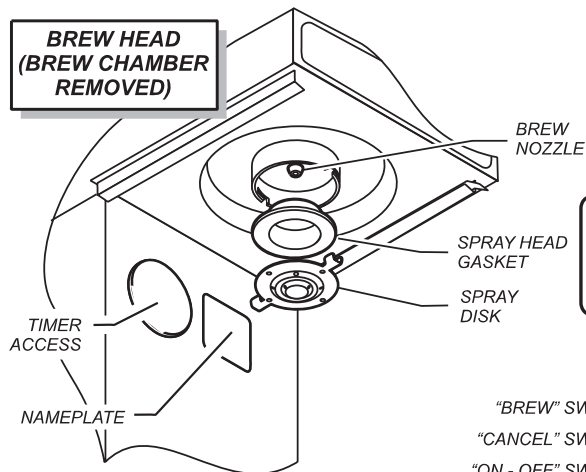

Fig. 1 Features & Operating Controls

PRECAUTIONS AND GENERAL INFORMATION



WARNING: ELECTRIC SHOCK HAZARD

All servicing requiring access to non-insulated components must be performed by qualified service personnel. Do not open any access panels which require the use of tools. Failure to heed this warning can result in electrical shock.



WARNING: INJURY HAZARD

All installation procedures must be performed by qualified personnel with full knowledge of all applicable electrical and plumbing codes. Failure could result in property damage and personal injury.



WARNING: ELECTRIC SHOCK HAZARD

Brewer must be properly grounded to prevent possible shock hazard. DO NOT assume a plumbing line will provide such a ground. Electrical shock will cause death or serious Injury.



WARNING: BURN HAZARD

This appliance dispenses very hot liquid. Serious bodily injury from scalding can occur from contact with dispensed liquids.

This appliance is intended for commercial use only.

This appliance is intended for use to brew beverage products for human consumption. No other use is recommended or authorized by the manufacturer or its agents.

This appliance is intended for use in commercial establishments, where all operators are familiar with the appliance use, limitations and associated hazards. Operating instructions and warnings must be read and understood by all operators and users.

Except as noted, this piece of equipment is made in the USA and has American sizes on hardware. All metric conversions are approximate and can vary in size.

The following trouble shooting, component views and parts lists are included for general reference, and are intended for use by qualified service personnel.

This manual should be considered a permanent part of this appliance. The manual must remain with the appliance if it is sold or moved to another location.



CAUTION: EQUIPMENT DAMAGE

DO NOT plug in or energize this appliance until all Installation Instructions are read and followed. Damage to the Brewer will occur if these instructions are not followed.



CAUTION: BURN HAZARD

Exposed surfaces of the appliance, brew chamber and airpot may be HOT to the touch, and can cause serious burns.

AGENCY LISTING INFORMATION

This brewer is  and  listed under UL file E9253.

This brewer meets  Standard 4 only when installed, operated and maintained in accordance with the enclosed instructions.



E9253



E9253



STD 4

INSTALLATION INSTRUCTIONS

READ THIS CAREFULLY BEFORE STARTING THE INSTALLATION

IMPORTANT:

To enable the installer to make a quality installation and to minimize installation time, the following suggestions and tests should be done before the actual unit installation is started:



CAUTION: EQUIPMENT DAMAGE

DO NOT plug in or energize this appliance until all Installation Instructions are read and followed. Damage to the Brewer will occur if these instructions are not followed.



CAUTION: UNSTABLE EQUIPMENT HAZARD

It is very important for safety and for proper operation that the brewer is level and stable when standing in its final operating position. Provided adjustable, non-skid legs must be installed at each corner of the unit. Failure to do so will result in movement of the brewer which can cause personal injury and/or damage to brewer.

NOTE: Water supply inlet line must meet certain minimum criteria to insure successful operation of the brewer. Bloomfield recommends 1/4" copper tubing for installation of less than 12 feet and 3/8" for more than 12 feet from a 1/2" water supply line.

REFER TO EXPLODED VIEWS Pages 18 thru 20 for COMPONENT NAMES/NUMBERS

Unpack the unit. Inspect all components for completeness and condition. Ensure that all packing materials have been removed from the unit.

Verify that the Spray Head Gasket and Spray Disk are properly installed.

LEVELING THE UNIT

Verify that an adjustable leg is installed at each corner of the brewer, and that a rubber foot is installed on each leg.

Set Brewer in its operating location. Level the Brewer. A spirit level should be placed on the top of the unit, at the edge, as a guide when making level adjustments.

Level the unit from left to right and front to back by turning the adjustable feet. Be sure all four feet touch the counter to prevent tipping.

PLUMBER'S INSTALLATION INSTRUCTIONS

Brewer should be connected to a **POTABLE WATER, COLD WATER** line. Flush water line before connecting to Brewer.

DO NOT use a saddle valve with a self-piercing tap for the water line connection. Such a tap can become restricted by waterline debris. For systems that must use a saddle tap, shut off the main water supply and drill a 3/16" (minimum) tap for the saddle connection, in order to insure an ample water supply. Remember to flush the line prior to installing the saddle.

The brewer must be installed on a water line with average pressure between 20 PSI and 90 PSI. If your water pressure exceeds 90 PSI at anytime, a pressure regulator must be installed in the water supply line to limit the pressure to not more than 90 PSI in order to avoid damage to lines and solenoid.

A water shut-off valve should be installed on the incoming water line in a convenient location (Use a low restriction type valve, such as a 1/4-turn ball valve, to avoid loss of water flow thru the valve.

The provided water line strainer must be installed in the supply line, between the shutoff valve and inlet fitting. Note FLOW arrow marking on strainer body.

INSTALLATION INSTRUCTIONS (continued)

NSF requires that the brewer be able to be moved for cleaning underneath. A flex line or loops of copper tubing will satisfy this requirement. See Figure 2 below.

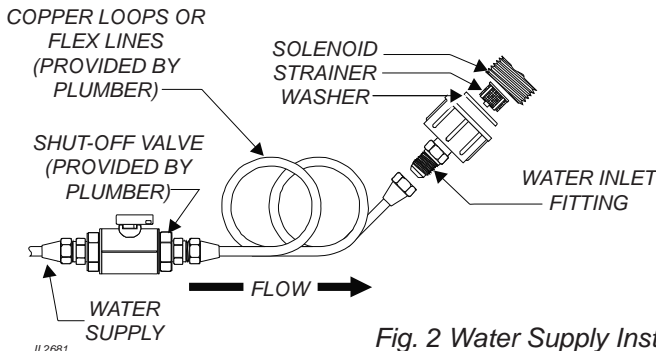

Fig. 2 Water Supply Installation

In some areas, local codes require a backflow preventer (check valve) to be installed on the inlet water line. If a backflow preventer is used, you must install a water hammer arrester in the incoming line, between the backflow preventer and the brewer inlet, as far away from the brewer as space will allow. This will relieve the excessive back pressures that can cause faucet leaks and solenoid malfunctions.

ELECTRICIAN'S INSTALLATION INSTRUCTIONS

REFER TO ELECTRICAL SPECIFICATIONS - Page 1
Check the nameplate to determine correct electrical service required for the Brewer to be installed.

IMPORTANT: Before connecting to electricity, make sure automatic brewers are connected to the water supply.

Models 1882 and 1882CA are equipped with a cord and plug. They require a 115 - 125 volt 20 amp circuit (50/60 Hz, 2 wire plus ground, with NEMA 5-15R or 5-20R Receptacle).

IMPORTANT: Fill the water tank before energizing this unit:

1. Insert the brew chamber (empty) and place an empty airpot in place under the brew chamber.
2. Plug the unit into an appropriate receptacle.
3. Be sure the brewer is "off" (I.e. no LEDs are lit).
4. Press BREW key three (3) times.
5. Press CANCEL key once.

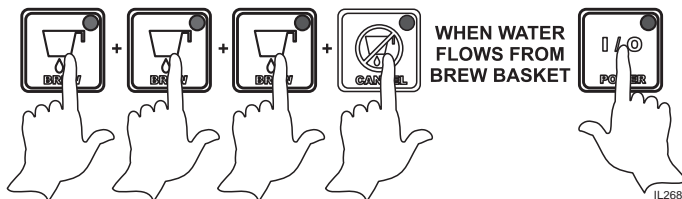

6. When water starts to flow from the brew chamber, press POWER key once. Unit will begin heating water in preparation for the first brew.

NOTE: This equipment must be installed to comply with applicable federal, state and local plumbing codes and ordinances.

WARNING:
ELECTRIC SHOCK HAZARD:

Brewer must be properly grounded to prevent possible shock hazard. DO NOT assume a plumbing line will provide such a ground. Electrical shock will cause death or serious injury.

IMPORTANT:

Supply power must match nameplate for voltage and phase. Connecting to the wrong voltage will damage the brewer or result in decreased performance. Such damage is not covered by warranty.

IMPORTANT: Do not connect brewer to electrical power until you are ready to fill the tank. See instructions at left.

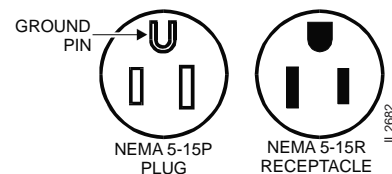

IMPORTANT: The ground prong of the plug is part of a system designed to protect you from electrical shock in the event of internal damage. Never cut off the ground prong nor twist a blade to fit an existing receptacle. Contact a licensed electrician to install the proper circuit and receptacle.

OPERATION

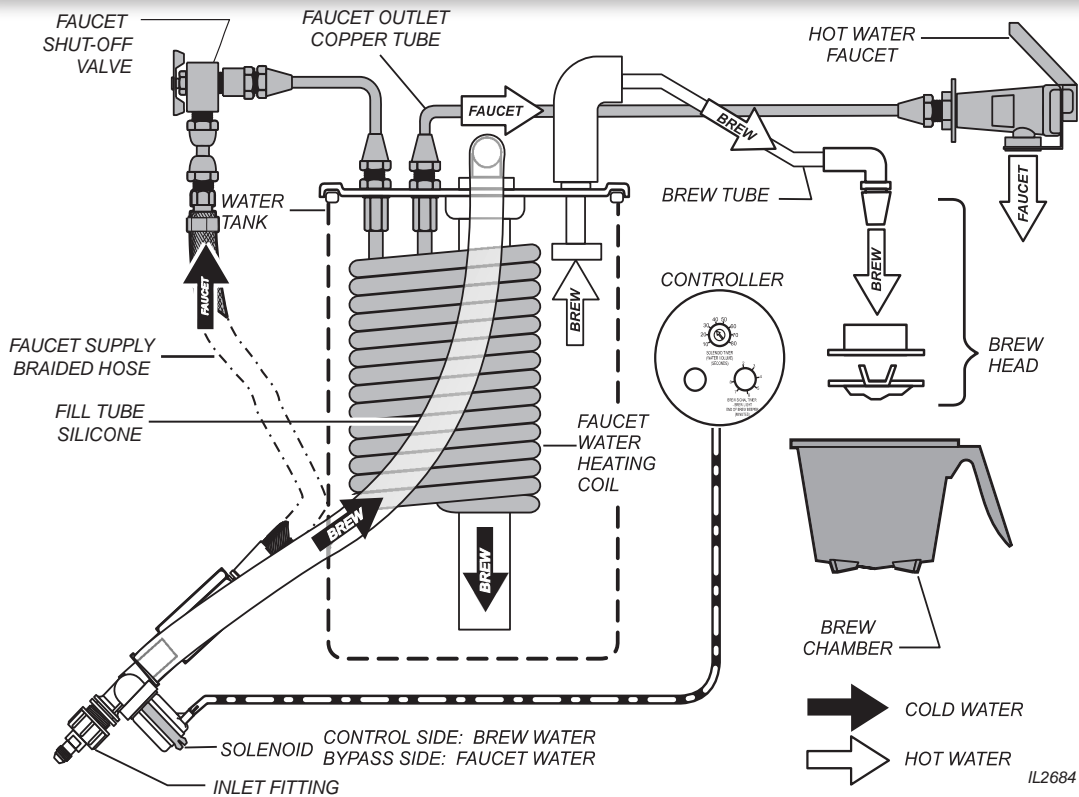

Fig. 3 Brewer Operation Diagram

IMPORTANT:

Tank must be full of water before pressing POWER key "on". Heating elements will be damaged if allowed to operate without being fully submerged in water.

Damage caused by operating the brewer without water in the tank is **NOT COVERED BY WARRANTY**.

A. START-UP

For initial start-up, or if the brewer has not been used for an extended period of time:

- Be sure spray disk and brew gasket are properly installed in the brew head.
- Be sure the water supply is properly connected and the water supply valve is turned ON.
- Be sure the WATER TANK IS FILLED.

IMPORTANT: Fill the water tank before energizing this unit:

1. Insert the brew chamber (empty) and place an empty airport in place under the brew chamber.
2. Plug the unit into an appropriate receptacle.
3. Be sure the brewer is "off" (i.e. no LEDs are lit).
4. Press START key three (3) times.
5. Press CANCEL key once.
6. When water starts to flow from the brew chamber, press POWER key once. Unit will begin heating water in preparation for the first brew. The heating elements will begin heating the water in the tank. When the water has reached the proper temperature, the "HEAT" light will go out.

OPERATION (continued)

WATER HEATER

Water temperature is sensed by an electronic water temperature probe inserted into the water tank. This temperature signal is fed to the controller.

The setpoint temperature is adjustable. The controller sends a command signal to the power board based upon a comparison between the setpoint temperature and actual temperature.

The power board energizes the heating elements based on the command signal from the controller.

Excessive temperature will trip the hi-limit safety switch. The hi-limit will automatically reset when the brewer cools.

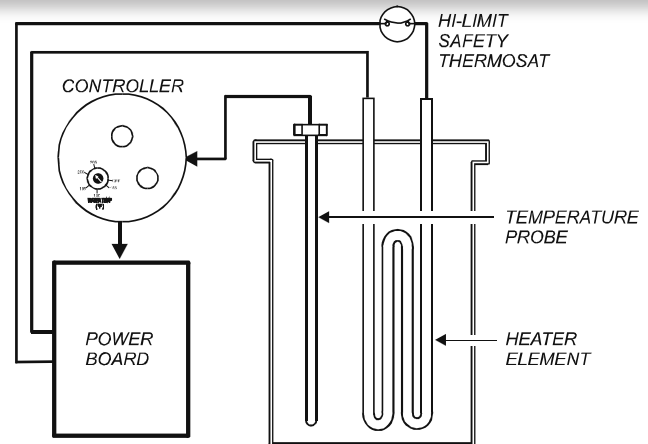

Fig. 4 Heat Control Diagram

WATER FLOW

AUTOMATIC OPERATION

Pressing the BREW key energizes the solenoid valve, allowing water from an external water supply to flow into the water tank. The incoming water forces heated water out of the tank to perform the brew.

The solenoid uses a flow control device so that flow is consistent between 20 p.s.i. and 90 p.s.i.

The length of time the solenoid is open is controlled by the time setting of the controller. After the solenoid closes, water will continue to flow to the brew chamber until the water level in the tank falls below the brew pickup, breaking the siphon.

HOT WATER FAUCET

The faucet water coil is submerged in the hot water tank and draws heat from the brew water. Water going to the water coil is not controlled by the solenoid valve.

Hot water is provided at the faucet, at supply water pressure, any time the faucet shut-off valve is OPEN.

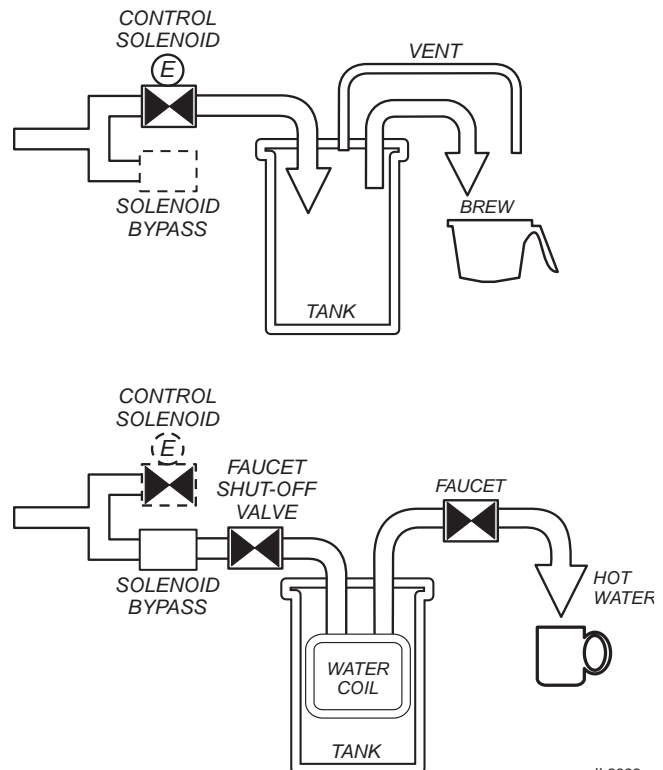

Fig. 5 Water Flow Diagram

BREWING COFFEE



CAUTION: BURN HAZARD

Exposed surfaces of the brewer, brew chamber and airpot may be HOT to the touch, and can cause serious burns.



CAUTION: BURN HAZARD

To avoid splashing or overflowing hot liquids, ALWAYS place an empty airpot under the brew chamber before starting the brew cycle. Failure to comply can cause serious burns.



CAUTION: BURN HAZARD

After a brew cycle, brew chamber contents are HOT. Remove the brew chamber and dispose of used grounds with care. Failure to comply can cause serious burns.

NOTE: The brewer will not initiate a second automatic brew cycle until the current cycle plus the drip-out time is completed. If the BREW key is pressed during this time, the BREW light will flash, indicating a brew in progress.

NOTE: Water for the hot water faucet is heated in a coil inside of the water tank. Use of the faucet will not affect the volume of water delivered for a brew. However, overuse of the faucet during a brew may lower the temperature of the brew water.

A. PREPARATION

Place one (1) genuine Bloomfield paper filter in the brew chamber. Add a pre-measured amount of fresh coffee grounds. Gently shake the brew chamber to level the bed of grounds. Slide the brew chamber into place under the brew head.

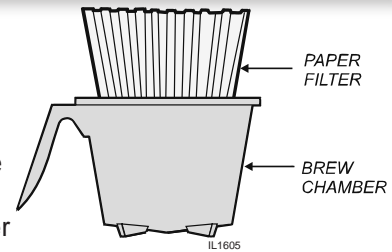

Fig. 6 Brew Chamber

B. AUTOMATIC OPERATION

BE sure "HEAT" light is not lit.

Place the appropriate EMPTY airpot in place under the brew chamber.

Press the "BREW" switch. The "BREW" light will glow and a beep will sound. The solenoid will open for an amount of time determined by the timer setting, admitting a measured quantity of water into the tank.

Inlet water will displace a like amount of heated water from the tank. The hot water will be forced into the brew head where it will spray over the bed of grounds. Freshly brewed coffee will begin to fill the container under the brew chamber.

At the end of the brew cycle, plus an amount of time set to allow all water to drip out of the brew chamber, two beeps will sound. When the flow and all dripping stops, the coffee is ready to serve.

Discard the contents of the brew chamber and rinse it in a sink. When the "READY TO BREW" light glows, the brewer is ready for another brew cycle.

CLEANING INSTRUCTIONS

PROCEDURE: Clean Coffee Brewer

PRECAUTIONS: Disconnect brewer from electric power.
Allow brewer to cool.

FREQUENCY: Daily

TOOLS: Mild Detergent, Clean Soft Cloth or Sponge
Bristle Brush, Bottle Brush

1. Disconnect brewer from electric power.
Allow brewer to cool before cleaning.
2. Remove airpot.
3. Remove and empty brew chamber.
4. Remove the spray disk from the brew head (See figure 7):
Press up on the spray disk ears, then turn the disk to the left to unlatch. Remove the gasket from inside the brew head.
5. Wipe inside of brew head and area around the brew head with a soft clean cloth or sponge moistened with clean water.
6. Wash the spray disk in a sink using warm water and a mild detergent. A bristle brush may be used to clear clogged spray holes. Rinse the spray disk with clean water and allow to air dry.
7. Wash the brew chamber in a sink using warm water and a mild detergent. A bristle brush may be used to clean the inside. Rinse with clean water and allow to air dry.
8. Wipe the exterior of the brewer with a soft clean cloth or sponge moistened with clean water.
10. Reinstall the gasket **INSIDE** the brew head, then reinstall the spray disk.
11. Reinstall the brew chamber.
12. **DO NOT** submerge airpots in water. Clean airpots by filling with warm soapy water. Scrub the inside with a bottle brush. Empty and rinse with clean water. Wipe the exterior with a soft clean cloth or sponge moistened with clean water. Invert and allow to air dry.

Procedure is complete



**CAUTION:
BURN HAZARD**

Brewing and serving temperatures of coffee are extremely hot. Hot coffee will cause serious skin burns.



**CAUTION:
ELECTRIC SHOCK
HAZARD**

Do not submerge or immerse brewer in water.

IMPORTANT:

DO NOT use steel wool, sharp objects, or caustic, abrasive or chlorinated cleansers to clean the brewer or airpots.

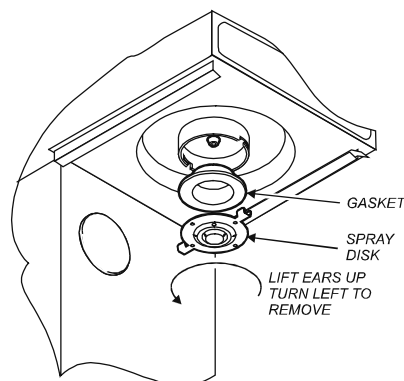

Fig. 7 Cleaning

TROUBLESHOOTING SUGGESTIONS

Symptoms	Possible Cause	Suggested Remedy
Water won't heat	Brewer unplugged or circuit breaker tripped	Check power supply cord, Check / reset circuit breaker
	Temperature setpoint too low	Set for desired temperature
	Hi-Limit safety switch tripped	Allow to cool hi-limit will self-reset
	Damaged internal component or wiring	Examine wiring & connectors, controller, power board and heating element. Repair/replace as needed
Coffee level too high or low	Timer out of adjustment	Adjust controller
Brew chamber overflows	Too many filter papers or wrong filter paper	Use one (1) genuine Bloomfield filter per brew
	Brew chamber dispense hole plugged	Thoroughly clean brew chamber
	Too much coffee or too fine a grind	Use correct grind and amount of coffee
Sprays water from brew head	Spray gasket improperly installed	Check/reinstall gasket on INSIDE of brew head
No brew (faucet flows OK)	Spray disk plugged	Clean spray disk
	Damaged internal component or wiring	Check keypad, controller, power board & solenoid. Repair, replace as needed
No brew plus no flow from hot water faucet	Water supply OFF	Turn water supply ON
	Solenoid inlet strainer plugged	Clean strainer
	Water filter (if used) plugged	Replace filter element
No flow from hot water faucet	Faucet valve turned OFF	Turn faucet valve ON
Poor coffee quality	Keep brewer and airpots clean.	
	Install a taste and odor filter in water supply, and replace cartridges regularly.	
	Use a quality coffee with a consistent roast. Use proper grind and amount of coffee per brew.	

SERVICING INSTRUCTIONS

ACCESS PANELS

TOP PANEL:

Remove top panel to access hot water tank, thermo probe, heating elements, brew circuit tubing, faucet valve and piping.

Top panel is held by two screws at the front and a retaining lip at the rear.

FRONT PANEL:

Remove front panel to access controller, power board and solenoid.

Front panel is held by two screws at the bottom and a retaining lip at the top.

SOLENOID DOOR:

Remove solenoid door to access solenoid plumbing connections.

Solenoid door is held by two screws and a retaining lip.



CAUTION:
ELECTRIC SHOCK
HAZARD

Opening access panels or removing warmer plates on this brew may expose uninsulated electrical components.

Disconnect brewer from electrical power before removing any panel.

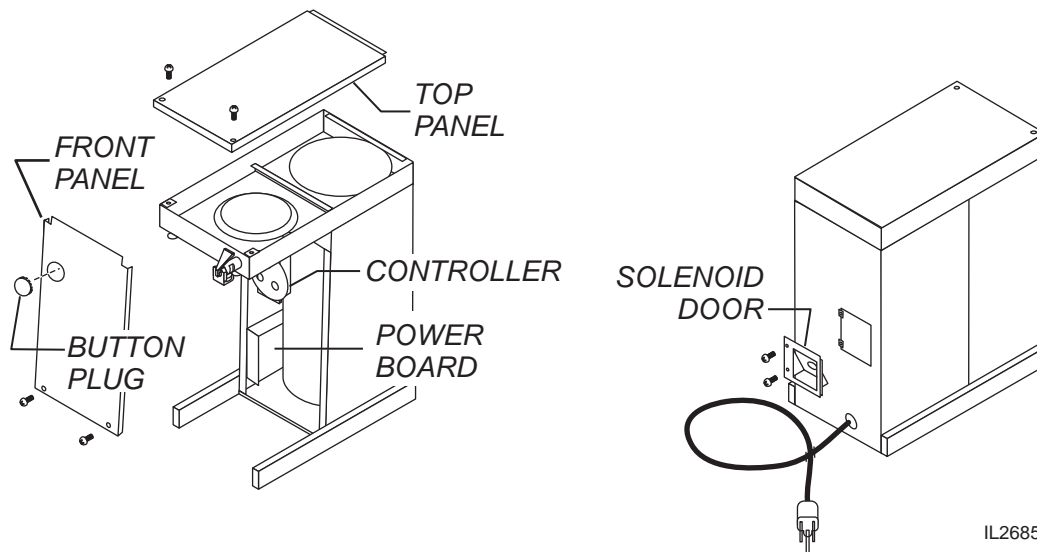

Fig. 8 Access Panels

IL2685

SERVICING INSTRUCTIONS (continued)

TEMPERATURE ADJUSTMENT

Unplug power cord or turn circuit breaker OFF. Remove top panel. Remove button plug from front panel.

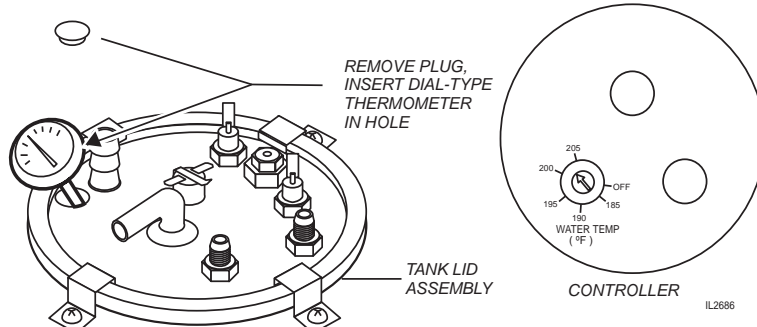

Fig. 9 Checking and Adjusting Brew Temperature

Pull vent tube out of tank lid and insert a thermometer of known accuracy in hole. Reconnect brewer to electrical power.

Place empty container under brew chamber. Energize brewer and allow unit to heat. When HEAT light goes out, read the temperature displayed on thermometer.

Adjust WATER TEMP dial on controller; clockwise increases temperature. Refer to Table 1 below for proper brewing temperature based on altitude.

Upon completion, remove thermometer and reinstall the plug.

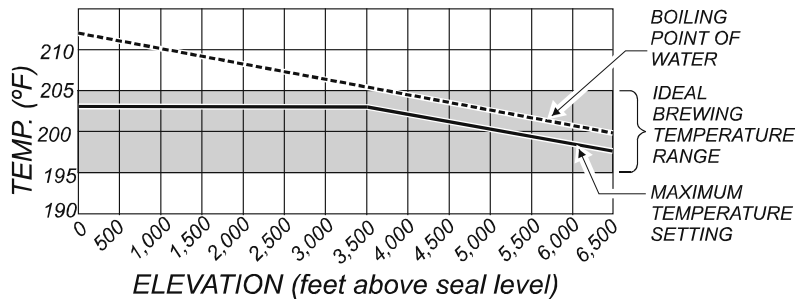

Table 1 Boiling Temperature by Altitude



CAUTION:
ELECTRIC SHOCK
HAZARD

These procedures involve exposed electrical circuits.

These procedures are to be performed by qualified technical personnel only.

NOTE: Optimum brewing temperature is 195°F to 205°F (90°C to 96°C).

Thermostat should be adjusted to a maximum temperature of 203°F (95°C).

IMPORTANT:

An electronic temperature controller will maintain temperature within $\pm 2^\circ\text{F}$.

To prevent boiling water in the brewer, controller should be adjusted to a maximum temperature equal to the local boiling temperature minus 2°F , or 203°F , whichever is less.

SERVICING INSTRUCTIONS (continued)

SOLENOID TIME ADJUSTMENT

The amount of water dispensed automatically during a brew cycle is controlled by the SOLENOID TIME section of the controller.

Place empty airpot under brew chamber. Press BREW button. Brewer should dispense one full airpot of water. To adjust amount:

Remove brew chamber and button plug. Adjust SOLENOID TIME dial on controller; clockwise increases time. Run several cycles to check amount of water delivered. Replace button plug.

In addition, water delivered to the brew chamber will take a while to drip through as coffee. Adjust the BREW SIGNAL TIMER dial on the controller to account for the dripout time.

REMOVE TANK LID ASSEMBLY

Unplug brewer or turn circuit breaker OFF. Turn OFF water supply. Remove top panel.

Disconnect brew fill and outlet tubes from tank lid fittings.

Disconnect faucet supply and outlet tubes from flare fittings on tank lid.

Disconnect all wiring from hi-limit and heating element.

Disconnect temperature probe from controller.

Loosen four lid clamp screws. Turn lid clamps out of the way. Remove cover assembly by lifting it straight up.

Reassemble in reverse order.

REPLACE TEMPERATURE PROBE

Unplug brewer. Remove top panel.

Loosen and free jam nut from pass-thru fitting securing temperature probe. Disconnect temperature probe wiring connector from controller.

Lift out probe, jamb nut and gasket.

Reassemble in reverse order.

REPLACE HEATING ELEMENT

Remove tank lid assembly per above.

Remove two hex nuts holding element to cover. Pull element from mounting holes.

Reassemble in reverse order.

IMPORTANT: Water pressure must be between 20 p.s.i and 90 p.s.i. flowing pressure. If water pressure exceeds this value, or if water pressure varies greatly, a pressure regulator must be installed in the water supply line.

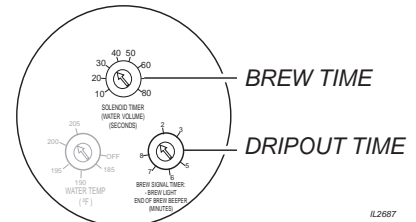

Fig. 10 Adjust Solenoid Time

IMPORTANT: Before setting assembly into tank, make sure tank lid gasket is properly seated on flange of lid.

IMPORTANT: When replacing temperature probe, be sure a new seal washer is in place around the probe. Tighten jamb lock nut only enough to ensure no water leakage. Excessive tightening is not necessary.

IMPORTANT: When replacing heating element, also replace seal gaskets.

SERVICING INSTRUCTIONS (continued)

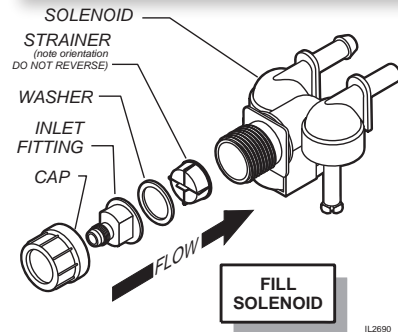

Fig. 11 Fill Solenoid

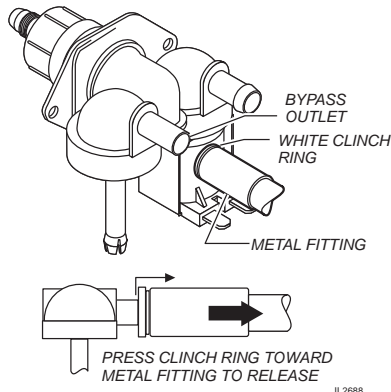

Fig. 12 Faucet Hose Fitting

IMPORTANT: When replacing water faucet coil, also replace seal gaskets.

NOTE: Any abrasion or roughness on the flat end of the seat cup will require replacing the seat cup:

Work the seat cup out of the bonnet and off of the end of the stem.

Install a new seat cup, making sure the knob on the stem is fully inserted into the pocket of the seat cup, and the skirt of the seat cup is fully inserted into the bonnet.

REPLACE SOLENOID

Unplug power cord. Turn OFF and disconnect water supply from brewer inlet fitting.

Remove front panel. Remove two screws holding access door in place. Remove access door and solenoid. Unscrew inlet fitting cap to release solenoid from door.

Remove wiring from solenoid.

Remove fittings from old solenoid and transfer to new solenoid. If necessary, replace flow control at this time.

Reassemble in reverse order.

REPLACE FAUCET SUPPLY HOSE

Unplug power cord. Turn OFF and disconnect water supply from brewer inlet fitting.

Disconnect hose fitting from solenoid by pressing the white clinch ring toward the metal hose fitting while sliding the fitting off of the solenoid bypass outlet.

Disconnect hose flare fitting from tank coil fitting.

Reassemble in reverse order.

REPLACE HOT WATER FAUCET COIL

(Symptom: Brewer drips continuously from brew head, except when faucet valve is turned OFF.)

Remove tank lid assembly per above.

Remove two hex nuts hot water coil to cover. Pull coil from mounting holes.

Reassemble in reverse order.

REPAIR HOT WATER FAUCET

Remove top panel and turn faucet valve OFF.

Unscrew aerator cap from faucet and remove handle retaining clip. Do not let faucet body turn.

Pull bonnet assembly from faucet body.

Examine the interior of the faucet body and the surface of the seat cup. Clean out any debris in the faucet body, using a stiff bristle brush if necessary.

Examine the aerator. Clean any debris from the screen or flow straightener, using a stiff bristle brush if necessary.

Reassemble in reverse order.

SERVICING INSTRUCTIONS (continued)

REPLACE CONTROLLER

Unplug power cord OFF.

Remove front panel. Remove timer faceplate. Disconnect keypad ribbon cable (note position "1"), temperature probe and power board cable.

Reassemble in reverse order. Be sure all jumpers are removed from the replacement controller.

Adjust controller as described on page 12 & 13.

REPLACE KEYPAD

Unplug power cord. Shut off water supply valve. Remove top and front panels. Remove faucet.

Disconnect ribbon cable from controller. Pry faceplate/keypad from body. Remove all adhesive residue.

Remove protective backing from adhesive on new keypad. Slide ribbon cable into slot on body from the outside, then carefully apply keypad to face of body.

Ribbon cable connects to P2 on controller. Note locator marking "1" on connector and cable.

Reassemble in reverse order. Test new keypad for function and proper operation.

REPLACE POWER BOARD

Unplug power cord. Shut off water supply valve. Remove front panel. Remove power board bracket from cabinet.

NOTE: position of wires at power board, then remove wires. Suggestion: Marking these wires is highly recommended to ease reinstallation.

NOTE: position of power board on bracket. Remove power board from bracket.

Reassemble in reverse order. Test for function and proper operation.

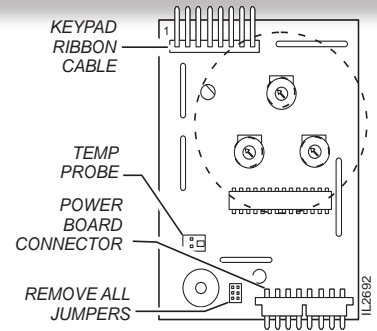

Fig. 13 Controller Hook-Up

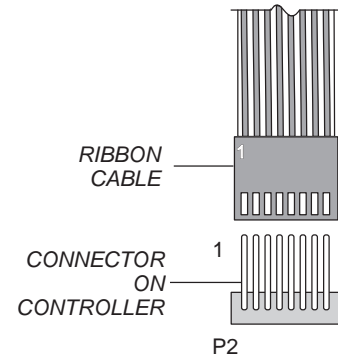

Fig. 14 Keypad Ribbon Cable Hook-Up

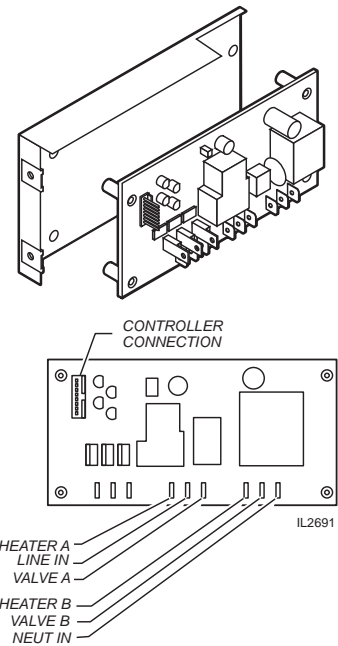

Fig. 15 Power Board Hook-Up

SERVICING INSTRUCTIONS (continued)



CAUTION: **CHEMICAL BURN** **HAZARD**

Deliming chemicals may be caustic.

Wear appropriate protective gloves and goggles during this procedure.

Never siphon deliming chemicals or solutions by mouth.

This operation should only be performed by qualified and experienced service personnel.

IMPORTANT: DO NOT spill, splash or pour water or deliming solution into or over any internal component other than the inside of the water tank.

IMPORTANT: DO NOT allow any internal components to come into contact with the deliming solution. Take care to keep all internal components dry.

NOTE: Repeat steps 4 thru 5 as required to remove all scale and lime build-up.

PROCEDURE: Delime the Water Tank

PRECAUTIONS: Disconnect brewer from electric power. Allow brewer to cool.

FREQUENCY: As required (Brewer slow to heat)

TOOLS: Deliming Solution
Protective Gloves, Goggles & Apron
Mild Detergent, Clean Soft Cloth or Sponge
Bristle Brush, Bottle Brush
Large Sink (or other appropriate work area)

1. Unplug power cord. Turn off the water shut-off valve and disconnect the water supply line from the brewer inlet fitting.
2. Remove the tank lid assembly as described on page 13.
3. Remove the water tank from the brewer body by lifting straight up. Empty all water from the tank. Set the tank back into the brewer.
4. Mix 2 quarts of deliming solution according to the manufacturer's directions. Carefully pour the deliming solution into the water tank. Lower the lid assembly back onto the tank. Allow to sit for 30 minutes, or as directed by the manufacturer.
5. At end of soaking period, remove lid assembly from tank. Thoroughly rinse internal components of lid assembly with clear water. Using a stiff bristle brush, scrub the heating element and faucet water coil to remove lime and calcium build-up. Rinse with clean water. Store lid assembly in a safe location.
6. Remove the tank from the brewer and empty. Using a stiff bristle brush, scrub the interior of the water tank to remove lime and calcium build-up. Rinse with clean water.

SERVICING INSTRUCTIONS (continued)

7. Set the tank back into the brewer. Reassemble the tank lid to the water tank. Make sure the gasket is properly in place, then reinstall lid clamps.
8. Reinstall wiring to heating element and thermostat. Reassemble piping for the faucet. Verify that all internal components are dry, then reinstall the top panel.
9. Reconnect brewer to electrical supply and reconnect water supply.
10. Install the brew chamber without filter paper or grounds. Run at least three full brew cycles and discard all water generated.
11. Brewer is ready to use.

NOTE: Normally, silicone hoses do not need to be delimed. Should deliming hoses become necessary, Bloomfield recommends replacing the hoses.

MODEL 1882: EXPLODED VIEW & PARTS LIST

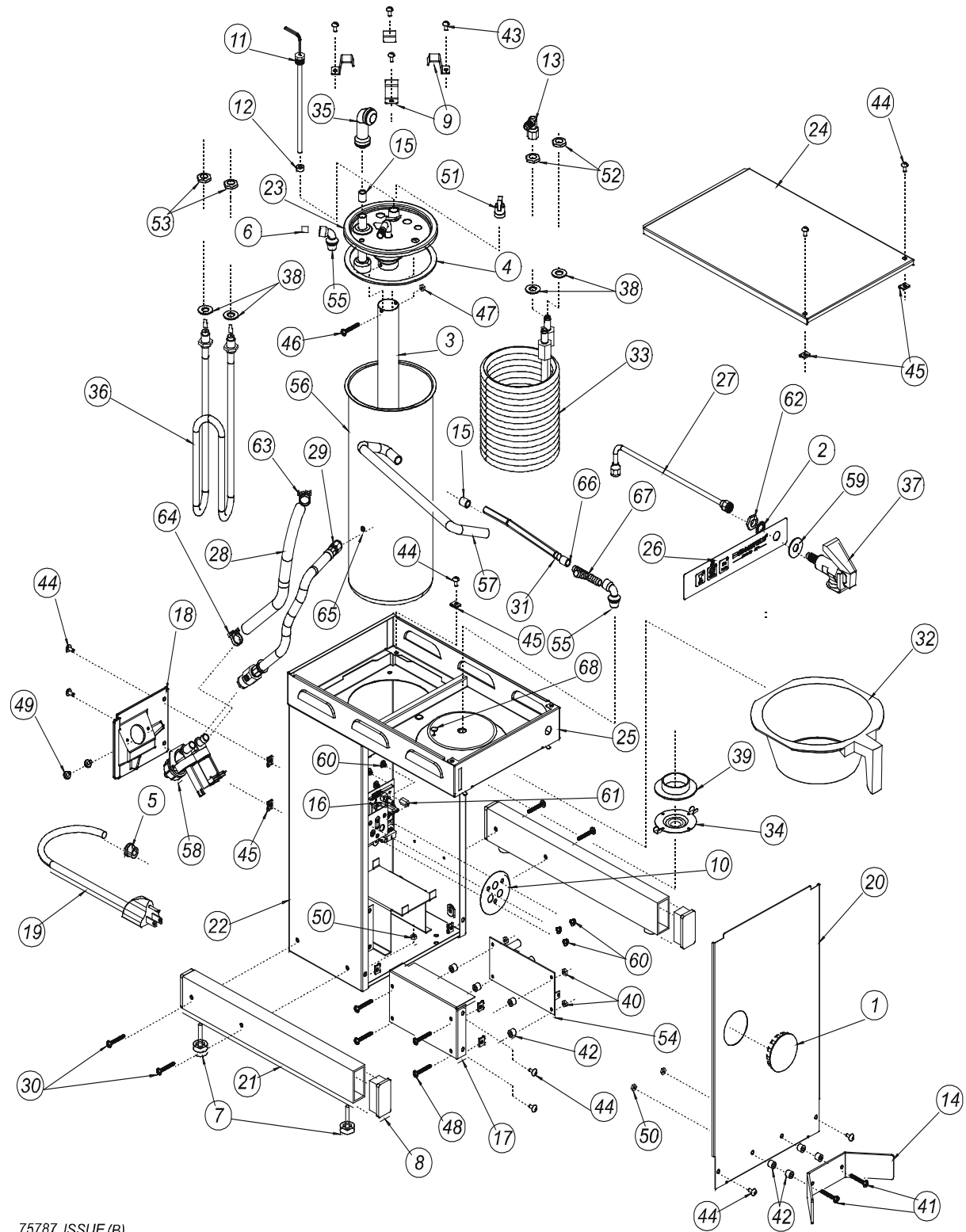

75787 ISSUE (B)

MODEL 1882: EXPLODED VIEW & PARTS LIST (continued)

Item	Part No.	Description	Qty
1	2P-70053	PLUG, BUTTON 2"	1
2	2C-70107	WASHER, FAUCET, SEMS 7/16EXT	1
3	2V-70104	TUBE, WATER INLET	1
4	2I-70147	GASKET TANK COVER	1
5	2K-70215	STRAIN RELIEF	1
6	2A-75609	TUBE 3/8 x 3/4" LG SS	1
7	2A-71732	LEG ASSY, LEVELLING	4
	2A-71732	LEVELLER, ADJUSTABLE LEG	
	2A-71732	CAP, ADJUSTABLE LEG	
8	2P-72159	CAP, LEG END	4
9	DD-73506	CLIP, RETAINING TANK LID	4
10	2M-73637	FACEPLATE, CONTROL BOARD	1
11	2J-73644	PROBE, TEMP 5-1/2" WITH NUT	1
12	2I-73731	SEAL, TEMP PROBE	1
13	2K-73745	ELBOW, SWIVEL, 1/4 MF x 1/4 FF	1
14	A6-73810	BRACKET, POSITIONING	1
15	DD-74629	TUBE .312 ID x .50 LG, SILICONE	2
16	2E-73635	CONTROL BOARD	1
17		BRACKET, CONTROL BOARD	1
18	2Q-75089	DOOR, SOLENOID ACCESS	1
19	A6-75536	CORD & CAP ASSY, NEMA 5-15P	1
20		PANEL, FRONT	1
21	DD-75559	LEG, ALUMINUM	2
22		BODY	1
23	DD-75624	ASSEMBLY, TANK COVER	1
24		TOP COVER	1
25		ASSEMBLY, UPPER HOUSING	1
26	2C-75660	OVERLAY, KEYPAD	1
27	DD-75776	TUBE, TANK TO FAUCET, METAL	1
28	DD-75777	TUBE, SOLENOID TO TANK	1
29	DD-75778	TUBE, BRAIDED W/BALL VALVE	1
30		SCREW 8-32 x 1-1/4 BK OX SS	4
31	DD-85808	TUBE, OUTLET TO SPRAY HEAD	1
32	2D-70234	BREW CHAMBER, BLACK	1
33	2N-70149	COIL, FAUCET WATER HEATING	1
35	2K-70101	ELBOW, INLET	1
36	2N-70143UL	ELEMENT, 120V, 1500W 1882CA	1
	2N-72299UL	ELEMENT, 120V, 1800W 1882	
37	WS-82556	FAUCET ASSEMBLY	1
38	2I-70152	GASKET, ELEMENT	4

Item	Part No.	Description	Qty
39	2I-72215	GASKET, SPRAYHEAD	1
40		NUT KEPS 6-32 LRG Ni	4
41		SCREW SLT RND 8-32 x 1-1/8	2
42	2A-43201	SPACER, 3/8" DIA x 5/16	8
43	DD-7506-39	SCREW PAN PH 8-32 x 1/2 SS	4
44	2C-70092	SCREW PH #8 x3/3 SMS SS	12
45	2C-70132	NUT #8 TNR Zi	12
46	2C-70145	SCREW PAN SLT 4-40 x 1-1/2	1
47	2C-70146	NUT HEX 4-40 SS	1
48	2C-70866	SCREW PAN PH 6-32 x 7/8 SS	4
49		SCREW PAN SLT 4mm x 6mm SS	2
50	2C-73457	NUT KEPS 8-32 SS	3
51	2T-47499	HI-LIMIT, 120V	1
52	2C-70151	HEX NUT 7/16-20 Brass	2
53	2C-70175	HEX NUT 1/2-20 Brass	2
54	2E-73636	POWER BOARD	1
55	2K-70103	ELBOW, OUTLET	2
56	2D-70110	TANK	1
57	DD-77001	TUBE SIL .312 x 17.75"	1
58	DD-75779	SOLENOID ASSY BYPASS .19 GPM	1
59	2C-72681	WASHER FLAT SS 1-1/8 x .048	1
60		SCREW PAN PH 6-32 x 3/8 SS	6
61	2C-73730	NUT, ALUMINUM 6-32 x .50"	3
62		NUT, FAUCET, HEX 7/16-20 Ni PLTD	1
63	2C-74211	CLAMP, 9/16 PLASTIC	1
64	2C-74212	CLAMP, 11/16 PLASTIC	1
65		SEAL, 1/4" FLARE	1
66		TUBE 3/8 x 1" SILICONE	1
67		TEE 3/8 BARB SS	1
68	2P-73319	PLUG TANK LID .298 DIA	1
	WS-POF	FILTER PAPER, pk of 1000	

EXPLODED VIEW & PARTS LIST (continued)

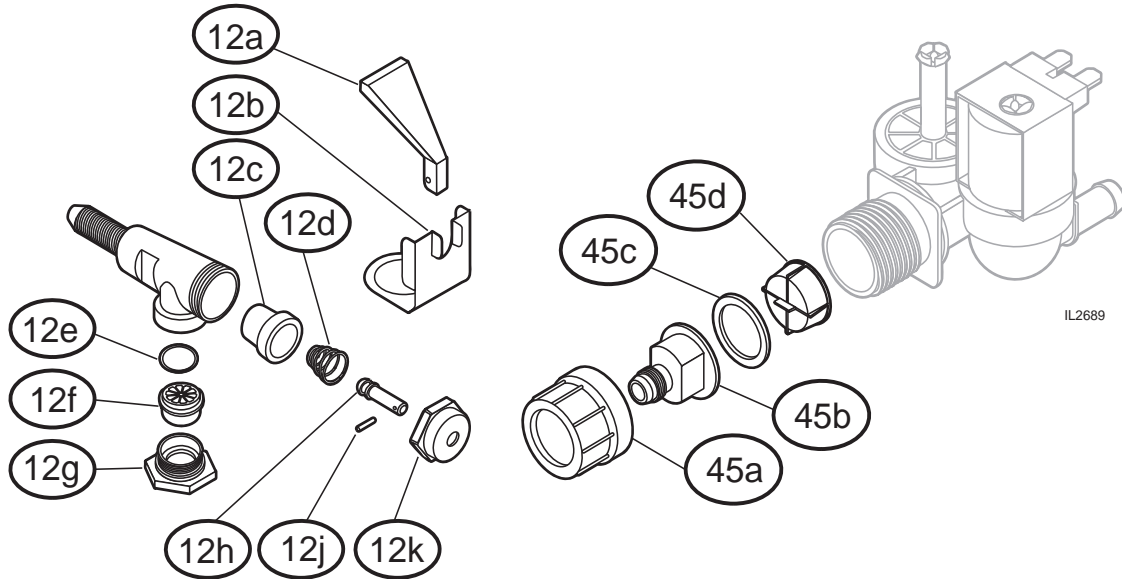

SERVICE KITS; FAUCET REPAIR KITS

WS-82573	Handle (item 12a)
WS-82575	Seat Cup (item 12c)
WS-82576	Faucet Repair Kit (Includes 12a Handle, 12c Seat Cup, 12d Spring, 12h Stem, 12j Pin & 12k Bonnet)
WS-82682	Retainer Clip (item 12b)
WS-84804	Aerator Replacement Kit (Includes 12e O-Ring, 12f Aerator Disk & 12g Aerator Cap)
WS-84870	Aerator Repair Kit (Includes 12e O-Ring & 12f Aerator Disk)

SOLENOID REPAIR KITS

2E-73612	Solenoid Complete, Single
DD-74291	Solenoid, Complete, with Bypass
WS-85218	Inlet Fitting Kit (items 45a, 45b, 45c, 45d)
WS-85219	Inlet Strainer (item 45d)

E.B.C.™ LO-PROFILE BREWER

MODEL	VOLTS	WATTS	AMPS
1882	120	1800	15.0
1882CA	120	1500	12.5

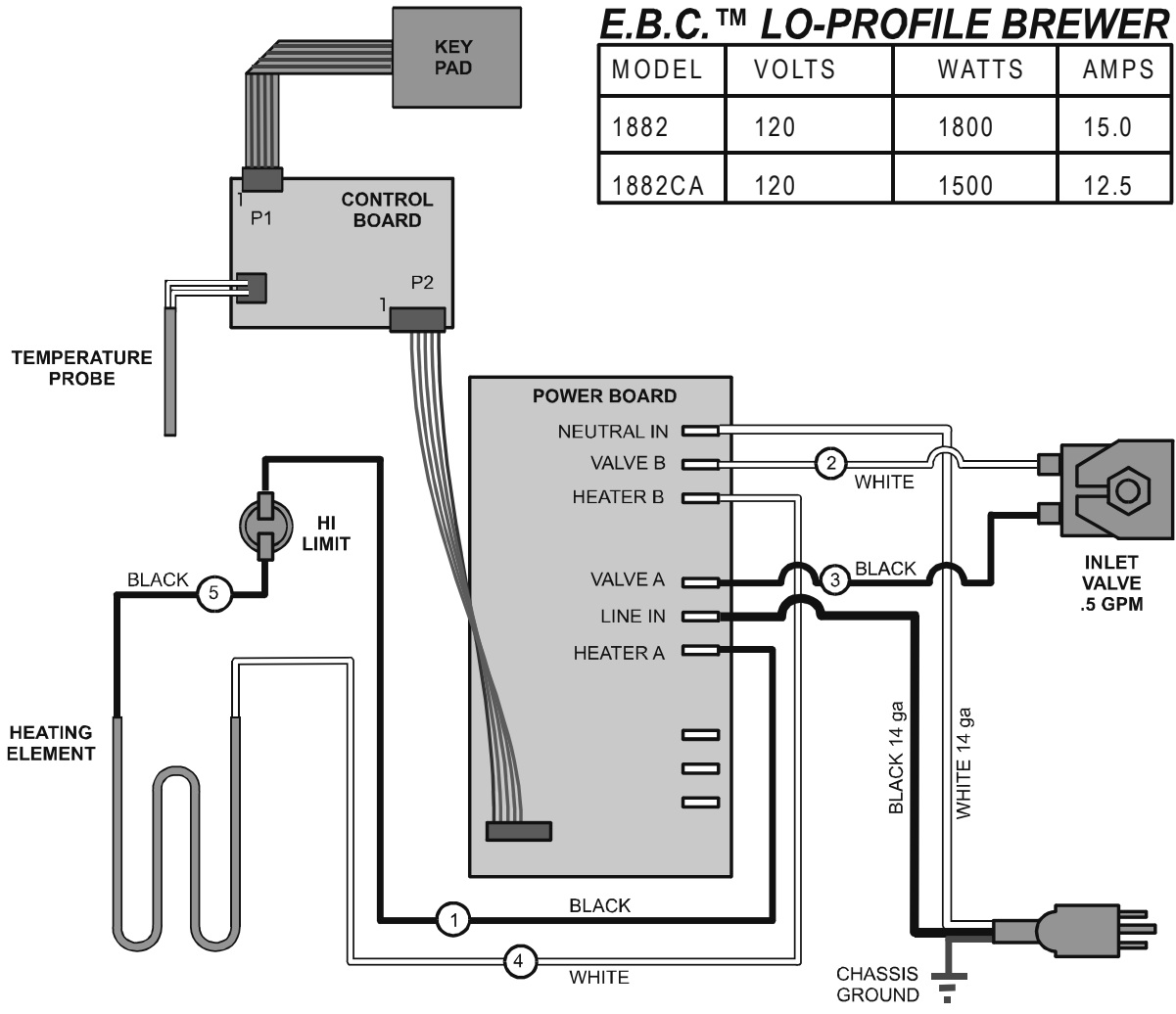



Wells Bloomfield proudly supports CFESA
Commercial Food Equipment Service Association

SERVICE TRAINING - QUALITY SERVICE



CUSTOMER SATISFACTION

 **BLOOMFIELD®**

WELLS BLOOMFIELD, LLC

10 Sunnen Drive, St. Louis, MO 63143
telephone: 314-678-6336 fax: 314-781-2714
www.wellsbloomfield.com