

MODEL: TVD THERMAL VECTOR
MAIN BREAKDOWN

STAR MANUFACTURING INTERNATIONAL, INC.
 SK2514 Rev. - 5/25/11



PARTS LIST

July 16, 2013, Rev. A

Model: TVD THERMAL VECTION				
Fig No.	Part Number	Quantity	Description	Application
1	A4-TVD016	1	ASM-BODY COVER	TVD30-120
	A4-TVD015			TVD50-120
2	2C-6349	23	SCREW #8X3/8 B THP STL NP	ALL
3	A4-Z14869	1	INSULATION, TOP-TVD30	TVD30-120
	A4-Z14038		INSULATION, TOP-TVD50	TVD50-120
4	2E-05-07-0351	1	TRANSFORMER 115/10V 6VA	ALL
5	2C-Z2594	10	NUT 6-32 HEX W STL NP	ALL
6	2E-05-07-0352	1	RELAY 30 AMP	ALL
7	2E-Z2894	1	TERMINAL BLOCK (304)	ALL
8	2K-76118	1	STRAIN RELIEF STR HEYCO 1	ALL
9	2A-Z11501	4	FOOT 1" SOLID RUBBER	ALL
10	2E-Z1470	1	SENSOR-RTD 2000 OHM	ALL
11	2K-08-07-0004	4	SPACER ROUND NYLON	ALL
12	2J-Z13971	1	CONTROL BOARD-SINGLE-TVD	ALL
13	2K-Z1971	4	SPACER .257X.75X.25 NYLON	ALL
14	2E-Z1858	1	SWITCH-LIGHTED	ALL
15	2R-Z14033	1	SLIDES-DWR-650MM-HI TEMP (SET)	ALL
16	2C-Z14859	8	SCREW-8-32X1 PH #100FL SS	ALL
17	2C-34285	10	SCREW 8-32X3/8 PH 100 FL	ALL
18	2N-Z14538	1	ELEMENT-675W-120V-10X18	TVD30-120
		2		TVD50-120
NI	A4-TVD022	1	INSULATION SET-TVD30	TVD30-120
NI	A4-TVD018	1	INSULATION SET-TVD50	TVD50-120
NI	A4-Z14679	1	CORD SET-120V-15A-RING TR	ALL

**IMPORTANT: WHEN ORDERING, SPECIFY VOLTAGE OR TYPE GAS DESIRED
INCLUDE MODEL AND SERIAL NUMBER**

PAGE 1
OF 1

Some items are included for illustrative purposes only and in certain instances may not be available.



Star Manufacturing International, Inc.

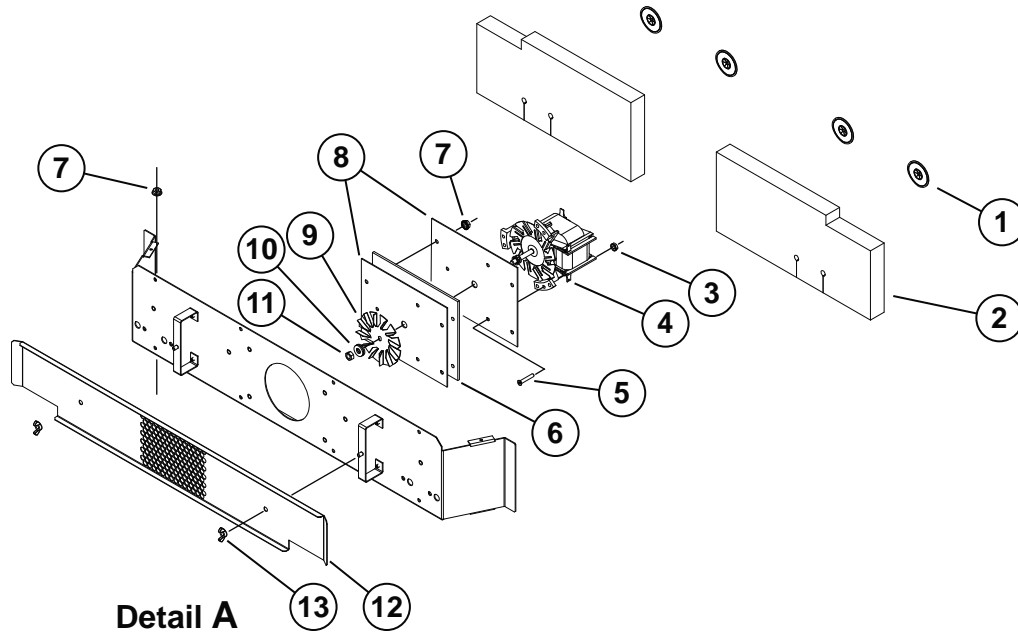

Detail B

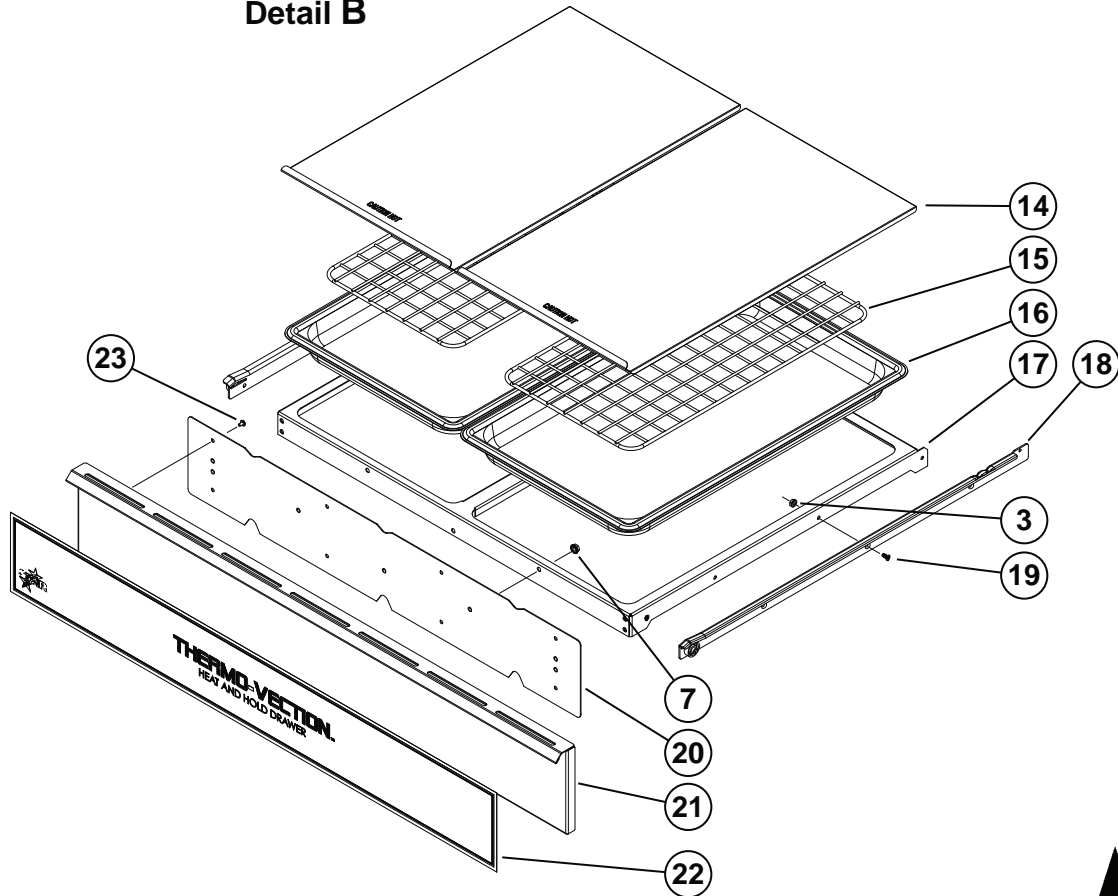

PARTS LIST

July 16, 2013, Rev. A

Model: TVD DETAIL A & B PARTS LIST				
Fig No	Part No	Qty	Description	Application
1	2C-Z14559	8	WASHER-INSULATION 4MM HLE	TVD30-120
		10		TVD50-120
2	A4-Z14871	1	INSULATION-REAR-TVD30 RT	TVD30-120
	A4-Z14872	1	INSULATION-REAR-TVD30 LT	
	A4-Z14040	2	INSULATION-REAR-TVD50	TVD50-120
3	2C-Z3447	19	NUT 8-32 HEX W SS	ALL
4	2U-Z14624	1	MOTOR,FAN-HI TEMP-120V	ALL
5	2C-Z14859	3	SCREW-8-32X1 PH #100FL SS	ALL
6	2H-Z14868	1	INSULATION, MOTOR-MICA	TVD30-120
	2H-Z14413			TVD50-120
7	2C-Z2893	30	NUT 10-24 HEX STL ZP	ALL
8	A4-Z14867	2	PLATE-MOTOR MOUNTING	TVD30-120
	A4-Z14412			TVD50-120
9	2R-Z14035	1	FAN BLADE, 3" CCW, 90 DEG	ALL
10	2C-1811	2	WASHER 1/4 BURR STL NP	ALL
	2C-08-07-0262	1	WASHER, SS 1/4 INT-LOCK	
11	2C-Z14640	1	NUT-M6X1-LH THREADS-SS	ALL
12	A4-Z14423	1	COVER, FAN-TVD50	ALL
13	2C-Z10133	2	NUT, WING 10-24	ALL
14	A4-Z14425	1	LID-SERVING PAN-FULL SIZE	TVD30-120
		2		TVD50-120
15	2B-Z14927	2	FALSE BTM-HALF PAN-WIRE	TVD30-120
	2B-Z16724		FALSE BTM-FULL PAN-WIRE	TVD50-120
16	2D-Z14928	2	PAN, HALF X 1.5" DEEP	TVD30-120
	2D-Z14047		PAN,FULL X 1.5" DEEP	TVD50-120
17	A4-Z14416	1	DRAWER FRAME-TVD30	TVD30-120
	A4-Z14415		DRAWER FRAME-TVD50	TVD50-120
18	2R-Z14033	1	SLIDES-DWR-650MM-HI TEMP (SET)	ALL
19	2C-34285	10	SCREW 8-32X3/8 PH 100 FL	ALL
20	A4-TVD012	1	ASM-DRAWER LINER-TVD30	TVD30-120
	A4-TVD011		ASM-DRAWER LINER-TVD50	TVD50-120
21	A4-TVD014	1	ASM-DRAWER FRONT	TVD30-120
	A4-TVD013			TVD50-120
22	2M-Z14414	1	OVERLAY-DWR FRNT-TVD30	TVD30-120
	2M-Z13862		OVERLAY-DWR FRNT-TVD50	TVD50-120
23	2C-200067	6	SCREW 6-32X1/4 THP SS	TVD30-120
		8		TVD50-120

**IMPORTANT: WHEN ORDERING, SPECIFY VOLTAGE OR TYPE GAS DESIRED
INCLUDE MODEL AND SERIAL NUMBER**

PAGE 1
OF 1

Some items are included for illustrative purposes only and in certain instances may not be available.



Star Manufacturing International, Inc.