

WELLS BLOOMFIELD, LLC
2 ERIK CIRCLE, P. O. Box 280 Verdi, NV 89439
telephone: 775-689-5703
fax: 775-689-5976
www.wellsbloomfield.com

351

OPERATION MANUAL

MODEL F-49RT COUNTERTOP PASTA REETHERMALIZER

Includes
**INSTALLATION
USE & CARE**



Model F-49RT

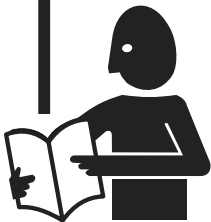

IMPORTANT: DO NOT DISCARD THIS MANUAL

This manual is considered to be part of the appliance and is to be given to the OWNER or MANAGER of the restaurant, or to the person responsible for TRAINING OPERATORS of this appliance. Additional manuals are available from your WELLS DEALER.

THIS MANUAL MUST BE READ AND UNDERSTOOD BY ALL PERSONS USING OR INSTALLING THIS APPLIANCE. Contact your WELLS DEALER if you have any questions concerning installation, operation or maintenance of this equipment.

PRINTED IN UNITED STATES OF AMERICA

LIMITED WARRANTY STATEMENT

Unless otherwise specified, all commercial cooking equipment manufactured by WELLS BLOOMFIELD, LLC is warranted against defects in materials and workmanship for a period of one year from the date of original installation or 18 months from the date of shipment from our factory, whichever comes first, and is for the benefit of the original purchaser only.

THIS WARRANTY IS THE COMPLETE AND ONLY WARRANTY, EXPRESSED OR IMPLIED IN LAW OR IN FACT, INCLUDING BUT NOT LIMITED TO, WARRANTIES OF MERCHANTABILITY OR FITNESS FOR ANY PARTICULAR PURPOSE, AND/OR FOR DIRECT, INDIRECT OR CONSEQUENTIAL DAMAGES IN CONNECTION WITH WELLS BLOOMFIELD PRODUCTS.

This warranty is void if it is determined that, upon inspection by an authorized service agency, the equipment has been modified, misused, misapplied, improperly installed, or damaged in transit or by fire, flood or act of God. It also does not apply if the serial nameplate has been removed, or if service is performed by unauthorized personnel. The prices charged by Wells Bloomfield for its products are

based upon the limitations in this warranty. Seller's obligation under this warranty is limited to the repair of defects without charge by a Wells Bloomfield factory authorized service agency or one of its sub-service agencies. This service will be provided on customer's premises for non-portable models. Portable models (a device with a cord and plug) must be taken or shipped to the closest authorized service agency, transportation charges prepaid, for service. In addition to restrictions contained in this warranty, specific limitations are shown in the Service Policy and Procedure Guide. Wells Bloomfield authorized service agencies are located in principal cities. This warranty is valid in the United States and Canada and void elsewhere. Please consult your classified telephone directory, your foodservice equipment dealer or contact:

**Service Department, Wells Bloomfield, LLC
P.O. Box 280, Verdi, Nevada 89439
phone (775) 689-5707 or fax (775) 689-5976**

for information and other details concerning warranty.

SERVICE POLICY AND PROCEDURE GUIDE and ADDITIONAL WARRANTY EXCLUSIONS

1. Resetting of safety thermostats, circuit breakers, over load protectors, and/or fuse replacements are **not** covered by this warranty unless warranted conditions are the cause.
2. All problems due to operation at **voltages or phase other than specified on equipment nameplates** are **not** covered by this warranty. Conversion to correct voltage and/or phase must be the customer's responsibility.
3. All problems due to **electrical connections not made in accordance with electrical code requirements and wiring diagrams** supplied with the equipment are **not** covered by this warranty.
4. Replacement of items **subject to normal wear**, to include such items as knobs, light bulbs; and, normal maintenance functions including adjustments of thermostats, adjustment of micro switches and replacement of fuses and indicating lights are **not** covered by warranty.
5. Damage to electrical cords and/or plug due to exposure to excessive heat are **not** covered by this warranty.
6. Full use, care, and maintenance instructions supplied with each machine. Noted maintenance and preventative maintenance items, such as servicing and cleaning schedules, are customer responsibility. Those miscellaneous adjustments noted are customer responsibility. Proper attention to preventative maintenance and scheduled maintenance procedures will prolong the life of the appliance.
7. Travel mileage is limited to **sixty (60) miles** from an Authorized Service Agency or one of its sub-service agencies.
8. All labor shall be performed during regular working hours. Overtime premium will be charged to the buyer.
9. All genuine Wells replacement parts are warranted for ninety (90) days from date of purchase on non-warranty equipment. This parts warranty is limited only to replacement of the defective part(s). **Any use of non-genuine Wells parts completely voids any warranty.**
10. Installation, labor, and job check-outs are **not** considered warranty and are thus **not** covered by this warranty.
11. Charges incurred by delays, waiting time or operating restrictions that hinder the service technician's ability to perform service are **not** covered by warranty. This includes institutional and correctional facilities.

SHIPPING DAMAGE CLAIM PROCEDURE

NOTE: For your protection, please note that equipment in this shipment was carefully inspected and packaged by skilled personnel before leaving the factory. Upon acceptance of this shipment, the transportation company assumes full responsibility for its safe delivery.

IF SHIPMENT ARRIVES DAMAGED:

1. **VISIBLE LOSS OR DAMAGE:** Be certain that any visible loss or damage is noted on the freight bill or express receipt, and that the note of loss or damage is signed by the delivery person.
2. **FILE CLAIM FOR DAMAGE IMMEDIATELY:** Regardless of the extent of the damage.

3. **CONCEALED LOSS OR DAMAGE:** if damage is unnoticed until the merchandise is unpacked, notify the transportation company or carrier immediately, and file "CONCEALED DAMAGE" claim with them. This should be done within fifteen (15) days from the date the delivery was made to you. Be sure to retain the container for inspection.

Wells Bloomfield cannot assume liability for damage or loss incurred in transit. We will, however, at your request, supply you with the necessary documents to support your claim.

TABLE OF CONTENTS

WARRANTY	xi
SPECIFICATIONS	1
FEATURES & OPERATING CONTROLS	2
PRECAUTIONS & GENERAL INFORMATION	3
AGENCY LISTING INFORMATION	4
INSTALLATION	4
OPERATION	6
CLEANING INSTRUCTIONS	7
MAINTENANCE	8
TROUBLESHOOTING SUGGESTIONS	8
PARTS & SERVICE	9
CUSTOMER SERVICE DATA	9

INTRODUCTION

Thank You for purchasing this Wells Bloomfield appliance.

Proper installation, professional operation and consistent maintenance of this appliance will ensure that it gives you the very best performance and a long, economical service life.

This manual contains the information needed to properly install this appliance, and to use and care for the appliance in a manner which will ensure its optimum performance.

SPECIFICATIONS

MODEL	VOLTS	AMPS	WATTS	POWER SUPPLY CORD
F-49RT	208 VAC 1 ϕ	16.6 A	3,450W	NEMA 6-30P
	240 VAC 1 ϕ	19.2A	4,600W	NEMA 6-30P

FEATURES & OPERATING CONTROLS

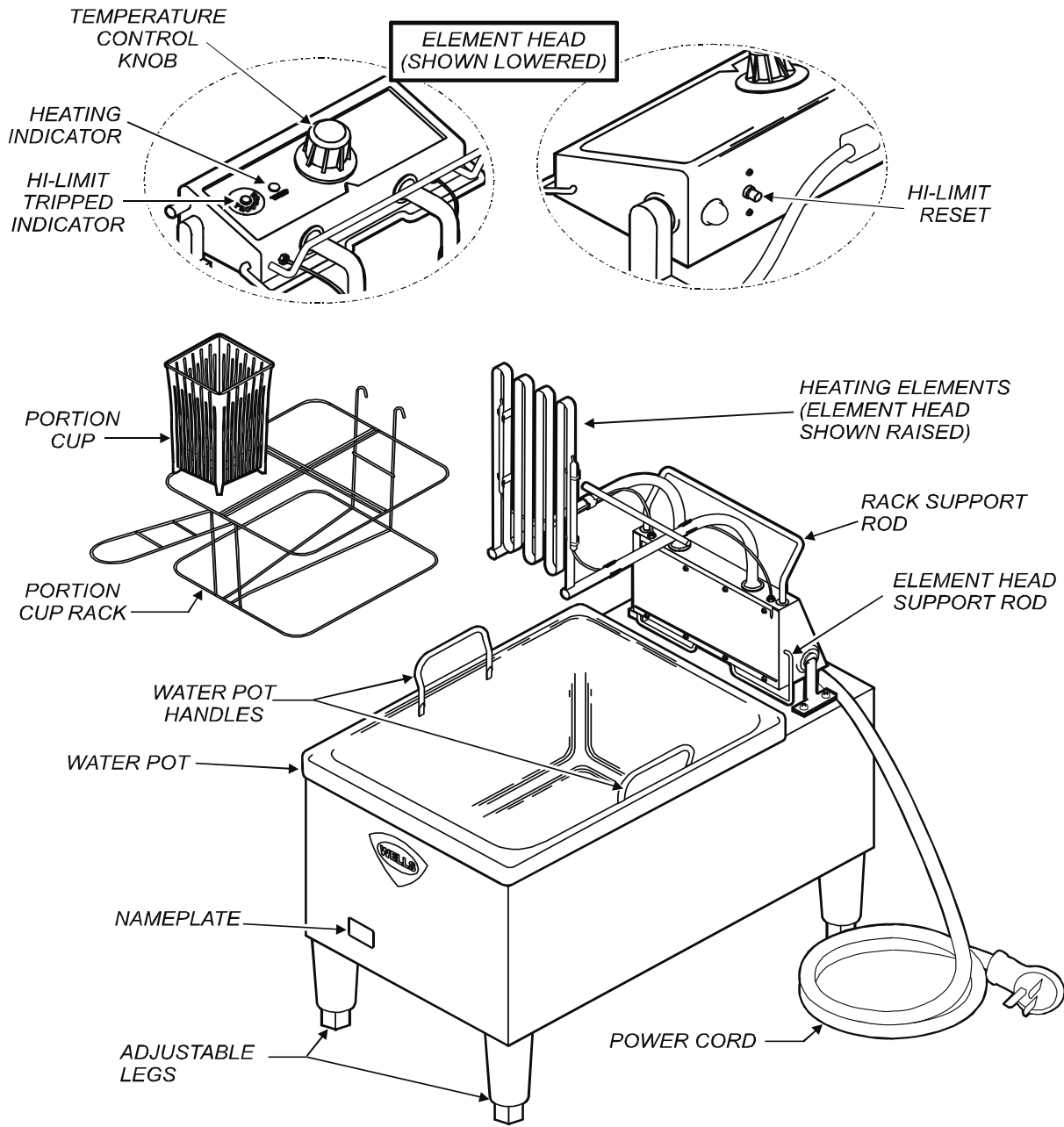

Fig. 1 F-49RT Countertop Rethermalizer Features & Operating Controls

351 p/n 304366 OpM Countertop Rethermalizer F-49RT

PRECAUTIONS AND GENERAL INFORMATION



WARNING: BURN HAZARD

Contact with boiling water can cause severe burns. Always wear protective clothing and heat resistant gloves when operating the appliance.



WARNING: ELECTRIC SHOCK HAZARD

All servicing requiring access to non-insulated components must be performed by qualified service personnel. DO NOT open any access panel that requires the use of tools. Failure to heed this warning may result in severe electric shock.



CAUTION: BURN HAZARD

Contact with hot water may cause burns. DO NOT fill the water pot beyond the scribed water level line.

This appliance is intended for use in commercial establishments only.

This appliance is intended to prepare food for human consumption. No other use is recommended or authorized by the manufacturer or its agents.

Operators of this appliance must be familiar with the appliance use, limitations and associated restrictions. Operating instructions must be read and understood by all persons using or installing this appliance.

Cleanliness of this appliance is essential to good sanitation. Read and follow all included cleaning instructions and schedules to ensure the safety of the food product.

Disconnect this appliance from electrical power before performing any maintenance or servicing.

DO NOT submerge this appliance in water. This appliance is not jet stream approved. Do not direct water jet or steam jet at this appliance, or at any control panel or wiring. Do not splash or pour water on, in or over any controls, control panel or wiring.

Exposed surfaces of this appliance can be hot to the touch and may cause burns.

The technical content of this manual, including any wiring diagrams, schematics, parts breakdown illustrations and/or adjustment procedures, is intended for use by qualified technical personnel.

Any procedure which requires the use of tools must be performed by a qualified technician.

This manual is considered to be a permanent part of the appliance. This manual and all supplied instructions, diagrams, schematics, parts breakdown illustrations, notices and labels must remain with the appliance if it is sold or moved to another location.

This appliance is made in the USA. Unless otherwise noted, this appliance has American sizes on all hardware.



CAUTION: RISK OF DAMAGE

DO NOT connect or energize this appliance until all installation instructions are read and followed. Damage to the appliance will result if these instructions are not followed.



CAUTION: HOT SURFACE

Exposed surfaces can be hot to the touch and may cause burns.

AGENCY LISTING INFORMATION

This appliance conforms to NSF Standard 4 for sanitation only if installed in accordance with the supplied *Installation Instructions* and maintained according to the instructions in this manual.

This appliance is  Listed under UL File E6070 for 208V and 240V.



INSTALLATION

UNPACKING & INSPECTION

Carefully remove the appliance from the carton. Remove all protective plastic film, packing materials and accessories from the appliance before connecting electrical power or otherwise performing any installation procedure.

Carefully read all instructions in this manual and the *Installation Instruction Sheet* packed with the appliance before starting any installation.

Read and understand all labels and diagrams attached to the appliance.

Carefully account for all components and accessories before discarding packing materials. Store all accessories in a convenient place for later use.

COMPONENTS

- 1 ea. WATER POT
- 1 ea. PORTION CUP RACK
- 4 ea. PORTION CUP, PASTA
- 4 ea. ADJUSTABLE LEGS

SETUP

Setup the appliance only on a firm, level, non-combustible surface. Verify local codes for requirements. Concrete, tile, terrazzo or metal surfaces are recommended. Metal over combustible material may not meet code for non-combustible surfaces.

Install one adjustable leg at each corner of the unit by screwing the leg into the fitting on the bottom. With a spirit level, check that the appliance is level front-to-back and side-to-side. Verify that the unit sits firmly **ON ALL FOUR LEGS**.

The lower portions of the legs are adjustable by turning; adjust as required to level the appliance. All four legs must be adjusted to firmly contact the counter in order to prevent tipping.

Refer to the *Installation Instruction Sheet* for required clearances. Maintain required clearances between the appliance and adjacent combustible surfaces.

Avoid storing flammable or combustible materials in, on or near the appliance.

NOTE: DO NOT discard the carton or other packing materials until you have inspected the appliance for hidden damage and tested it for proper operation. Refer to *SHIPPING DAMAGE CLAIM PROCEDURE* on the inside front cover of this manual.

IMPORTANT:

This installation must comply with all applicable Federal, Local and NFPA codes.

SCREW INTO CABINET
MOUNTING HOLES



TURN TO
ADJUST HEIGHT

Fig. 2 Adjustable Legs



WARNING: ELECTRIC SHOCK HAZARD

All servicing requiring access to non-insulated electrical components must be performed by a factory authorized technician. DO NOT open any access panel which requires the use of tools. Failure to follow this warning can result in severe electrical shock.

F-49RT RETHERMALIZER ELECTRICAL INSTALLATION

This unit is equipped with a cord and NEMA 6-30P plug, and requires a properly installed NEMA 6-30R receptacle. Contact a licensed electrician to install an appropriate 208 VAC or 240 VAC 30 amp electric circuit and grounded receptacle.

Be sure the TEMPERATURE CONTROL KNOB is turned to the OFF position, then plug the POWER CORD into a matching receptacle.

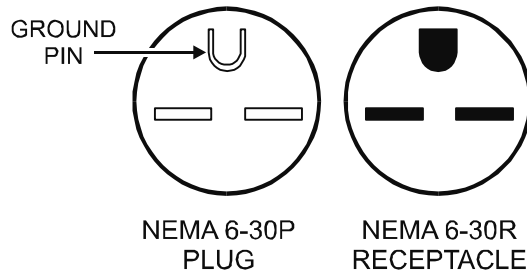

Fig. 3 F-49RT Power Plug and Receptacle Configuration



**CAUTION:
RISK OF
DAMAGE**

DO NOT connect or energize this appliance until all installation instructions are read and followed. Damage to the appliance will result if these instructions are not followed.



**CAUTION:
ELECTRIC SHOCK
HAZARD**

The ground pin of the power cord plug is part of a system designed to protect you from electric shock in the event of equipment damage. DO NOT cut the ground pin from the power cord plug in order to fit an existing receptacle; DO NOT twist a blade of the power cord plug in order to fit an existing receptacle.

Contact a licensed electrician to install an appropriate electrical circuit and receptacle.

IMPORTANT:

Damage due to being connected to the wrong voltage or phase is NOT covered by warranty.

OPERATION



WARNING: BURN HAZARD

Contact with boiling water can cause severe burns.
Always wear protective clothing and heat resistant gloves when operating the appliance.



CAUTION: HOT SURFACE

Exposed surfaces can be hot to the touch and may cause burns.

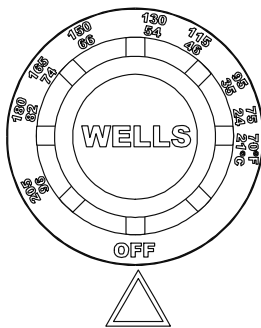

Fig. 3 Temperature Control Knob

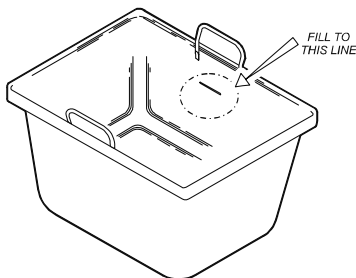

Fig. 4 Water Level Marking

NOTE: If the water pot is allowed to boil dry and exceeds 275°F, the hi-limit safety will shut down the unit and light the red TROUBLE indicator. To reset: Allow the water pot to cool, refill with fresh water, then press the red button on the back of the element head until it “clicks” and stays in. If tripping persists, see Troubleshooting Suggestions, page 8.

NORMAL OPERATION

- Be sure the TEMPERATURE CONTROL KNOB is turned to **OFF**.
 - Lower the ELEMENT HEAD into the frypot by pushing back on the BASKET SUPPORT ROD, raising the ELEMENT HEAD SUPPORT ROD, then carefully lowering the elements.
- Fill the WATER POT with fresh water to the scribed water level line. Capacity: 9 quarts
IMPORTANT: DO NOT overfill the water pot. Cold water will expand as it heats. Adding too much water will allow the water pot to overflow during operation. Water will evaporate, and be captured by the food product during cooking. For best results, maintain proper water level in the water pot during operation.
- Turn the TEMPERATURE CONTROL KNOB to the desired temperature. The HEAT INDICATOR will glow. When the water reaches the desired temperature, the heat indicator will go out. The heat indicator will go off and on during operation as the thermostat cycles to maintain temperature.
Pre-heat times 70°F to 210°F (approximate):
F-49RT (208 volts) - 20 minutes
F-49RT (240 volts) - 10 minutes
- Load one to four portion cups no more than 1/2 full with pasta.
 - DO NOT overload portion cups. For best results, load portion cups uniformly to half full.
 - Using the handle, lower the rack into the hot water. Cooking time is approximately 30 seconds.
 - When food is cooked, lift the rack out of the water by the handle. Hang the rack on the RACK SUPPORT ROD to drain.
- When the heat indicator light cycles off, the rethermalizer is ready to cook the next load.
Approximate performance guide (refrigerated to serving temperature)
F-49RT (208 volts) - 120 4 oz. servings per hour
F-49RT (240 volts) - 180 4 oz. servings per hour
- Reduce temperature control to 150°F or less during idle periods to save power. The rethermalizer will return to operating temperature in just a few minutes when needed.
- Keep the rethermalizer clean at all times. Rinse portion cups and baskets frequently to minimize starch build up,
- Drain the rethermalizer completely after use. Replace the water in the water pot daily, or more often if starch build up is excessive. Allow the water pot to cool before removing it from the cabinet.

CLEANING INSTRUCTIONS



WARNING: BURN HAZARD

Contact with hot water can cause severe burns. Allow the appliance to cool before cleaning. Always wear protective clothing and heat resistant gloves when cleaning the rethermalizer.

PREPARATION

Turn temperature control to *OFF*
Unplug appliance from receptacle and allow to cool completely before cleaning

FREQUENCY

Daily, or as needed

TOOLS

Mild Detergent, Non-abrasive cleanser
Soft Cloth or Sponge, Plastic Scouring Pad

CLEANING

1. Turn temperature control to OFF. Unplug the unit.
2. Remove portion cups and rack, then swing the element head up and out of the water pot.
NOTE: The element support rod is spring-loaded. When the element head is raised, the support rod will automatically swing into position to keep the element head raised.
3. Allow the water to cool to a safe temperature (120°F or less). Carefully remove the water pot: wearing heat-resistant gloves, lift the water pot by the handles.
4. Water pot, portion cups and rack may be washed in a dishwasher, or with warm water and mild detergent. Rinse thoroughly and dry completely.
5. Wipe/brush all crumbs and cooking debris from elements. Pay particular attention to the area between the element and the thermobulbs. Be careful that the capillary tubes of the thermobulbs are not moved or damaged during cleaning.
6. Clean all exterior surfaces by wiping with a clean cloth dampened with warm water and mild detergent. A non-abrasive detergent and plastic scouring pad may be used for stubborn deposits.
IMPORTANT: DO NOT use steel wool or abrasive cleansers as these will damage the surface finish.
IMPORTANT: DO NOT submerge the appliance in water. DO NOT spill or pour water into controls, control panel or wiring. Damage to internal components will occur.
7. Reinstall the water pot in the cabinet.
 - a. Be sure the TEMPERATURE CONTROL KNOB is turned to *OFF*, then plug unit into receptacle.
 - b. Lower the ELEMENT HEAD into the water pot by pushing back on the ELEMENT LIFTING HANDLE, raising the SUPPORT ROD, then carefully lowering the elements.
 - c. Add fresh water to the MIN OIL line in water pot.

Procedure is complete.



CAUTION: ELECTRIC SHOCK HAZARD

Disconnect unit from electric power before cleaning.



CAUTION: BURN HAZARD

Allow unit to cool completely before cleaning.



CAUTION: ELECTRIC SHOCK HAZARD

Do not submerge unit in water.

IMPORTANT: DO NOT spill or pour water into controls, control panel or wiring.

DO NOT submerge unit in water. Damage to internal components will occur. Damage to internal components from water damage is **not** covered by warranty.

IMPORTANT: DO NOT use steel wool or abrasive cleansers for cleaning the cabinet or water pot.

TROUBLESHOOTING SUGGESTIONS

DESCRIPTION	POSSIBLE PROBLEM	SUGGESTED REMEDY
Unit will not heat	Not plugged in or circuit breaker tripped	Plug into proper receptacle Reset circuit breaker
	Temperature control knob not set to desired temperature	Set to desired temperature
	Hi-limit safety tripped	Clean element ¹ , reset hi-limit
	Damaged internal component	Contact Wells Authorized Service Agency for repairs
Unit will not maintain temperature	Temperature control thermostat thermobulb contaminated with cooking debris	Clean element ²
	Damaged internal component	Contact Wells Authorized Service Agency for repairs
Unit leaks water	Damaged water pot	Replace water pot (frypot)
Element head will not raise, will not stay in the up position, or will not lower	Water pot out of position, or has excess cooking debris in bottom	Check water pot for position Clean water pot
	Damaged hinge bracket or support rod	Contact Wells Authorized Service Agency for repairs

¹ The hi-limit safety is designed to shut down the unit if water pot is allowed to boil dry and temperature exceeds 275°F. However, a build-up of cooking debris between the heating element and the thermobulb of the hi-limit safety will cause the hi-limit to trip prematurely. Clean the element so that water may circulate freely between the element and the thermobulb. Reset the safety by pressing the red button on the back of the element head.

² A build-up of cooking debris between the heating element and the thermobulb temperature control thermostat will cause inconsistent temperatures. Clean the element so that water may circulate freely between the element and the thermobulb.

WIRING DIAGRAM FOR F-49RT

208V OR 208/240V SINGLE PHASE

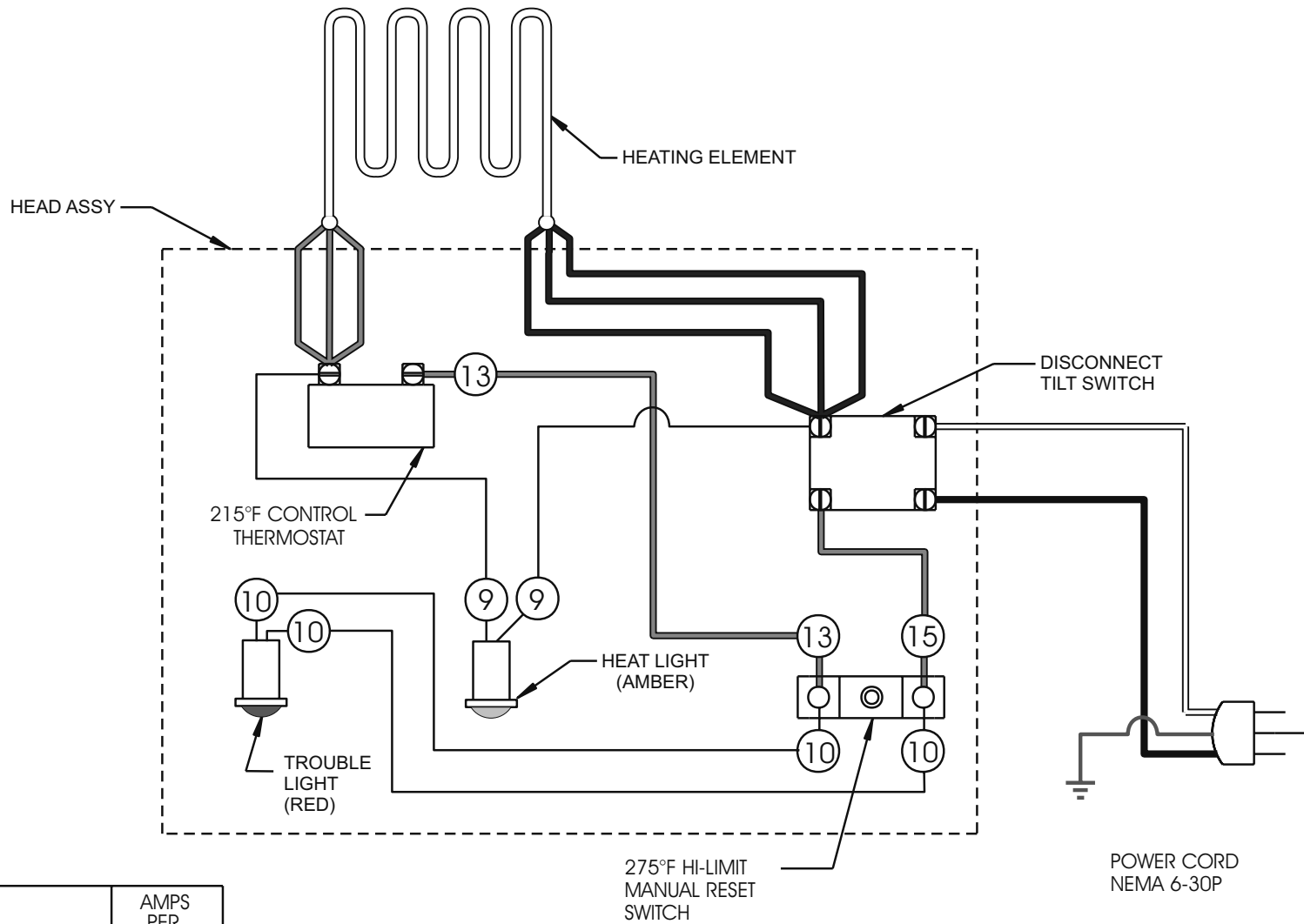

WATTS	VOLTS	AMPS PER PHASE
3.5/4.6 KW	208/240	16.6/19.1
4.6 KW	208	22.1

PART #	DESCRIPTION	PART #	DESCRIPTION	PART #	DESCRIPTION
OPTIONAL ACCESSORIES		MECHANICAL		HARDWARE, etc.	
20141	CORDSET FOR F-49RT	51206	BASKET ROD	50172	NUT, FRYER ELEMENT
20314	LEGS, 4" PLASTIC (pk 4)	52427	SUPPORT ROD, CONTROL HEAD	50176	LOCK WASHER, ELEMENT (pk 10)
20563	LEGS, 4" METAL (pk 4)	52428	SPRING, SUPPORT ROD	50177	FIBER WASHER, ELEMENT
21365	BASKET, PASTA (pk 4)	53435	BRACKET, PIVOT F-49RT	50789	STRAIN RELIEF
21747	RACK, PORTION CUP	53436	WASHER, SLOTTED PIVOT F-49RT	51053	NUTS, 8-32 KEPS (pk 100)
21748	COOKPOT, F-49RT	54452	RETAINER, BASKET ROD	51207	WASHER, SS BASKET ROD
		66648	KNOB, TEMP CONTROL	51208	WASHER, NEOPRENE BASKET ROD
				51717	SCREW 8-32 x 7/8 PH FL
				51718	SCREW 8-32 x 3/16 RD (pk 10)
				51881	SLEEVING VARGLAS 5/8 DIA
				53890	SCREW 12-24 x3/4 (pk 10)
				53935	SCREW #6SMS x 1/4 (pk 100)
ELECTRICAL				55566	SCREW #6SMS # 1/4 TH SS (pk100)
50147	SAFETY SWITCH DISCONNECT			55736	NUT, 8-32 KEPS GREEN (pk 10)
50516	INDICATOR LIGHT, AMBER			69689	CLIP, THERMOBULB (pk 4)
50789	STRAIN RELIEF				
51157	INDICATOR LIGHT, RED				
62892	ELEMENT, 240V, F-49RT				
66548	THERMO CONTROL 215°F				
66549	THERMO SAF MAN RESET 275°F				

PL351 Service Parts List - F-49RT Countertop Pasta rethermalizer

F-49RT COUNTERTOP PASTA RETHERMALIZER

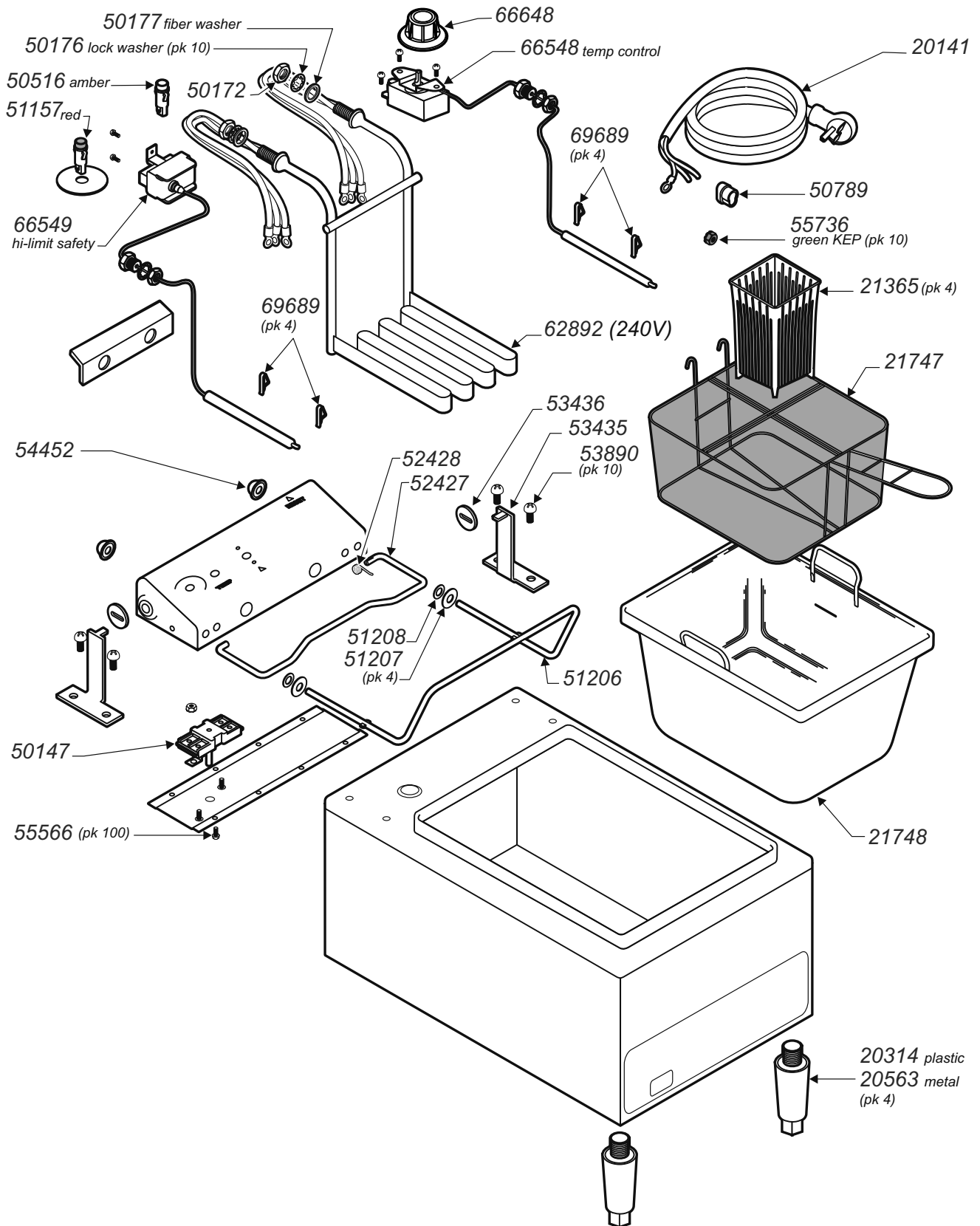

PL351 Service Parts List - F-49RT Countertop Pasta rethermalizer

PARTS & SERVICE

DESCRIPTION

PART NO.

LEGS, ADJUSTABLE (Set of 4)
COVER, FRYPOT
PORTION BASKET, PK OF 4
RACK, PORTION CUP
POT, SS WITH HANDLES
BASKET, SS 1/2 SIZE

20563
21010
21365
21747
21748
22070

IMPORTANT: Use only factory authorized service parts and replacement filters.

For factory authorized service, or to order factory authorized replacement parts, contact your Wells authorized service agency, or call:

Wells Bloomfield, LLC

2 Erik Circle
P. O. Box 280
Verdi, NV 89439

Service Parts Dept.
phone: (775) 689-5707
fax: (775) 689-5976

Service Parts Department can supply you with the name and telephone number of the **WELLS AUTHORIZED SERVICE AGENCY** nearest you.

CUSTOMER SERVICE DATA

please have this information available if calling for service

RESTAURANT _____ LOCATION _____
INSTALLATION DATE _____ TECHNICIAN _____
SERVICE COMPANY _____
ADDRESS _____ STATE _____ ZIP _____
TELEPHONE NUMBER (____) _____ - _____

EQUIPMENT MODEL NO. _____
EQUIPMENT SERIAL NO. _____
VOLTAGE: (check one) 208 240



Wells Bloomfield proudly supports CFESA
Commercial Food Equipment Service Association

SERVICE TRAINING - QUALITY SERVICE



CUSTOMER SATISFACTION

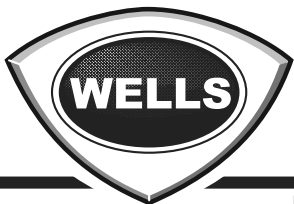

WELLS BLOOMFIELD, LLC
2 ERIK CIRCLE, P. O. Box 280 Verdi, NV 89439
telephone: 775-689-5703
fax: 775-689-5976
www.wellsbloomfield.com

PRINTED IN UNITED STATES OF AMERICA