

**WELLS MANUFACTURING**  
10 Sunnen Dr., St. Louis, MO 63143  
telephone: 314-678-6314  
fax: 314-781-2714  
[www.wellsbloomfield.com](http://www.wellsbloomfield.com)

101

## OWNERS MANUAL

## ELECTRIC COUNTERTOP GRIDDLES

**MODELS  
G13, G19,  
G23, G24,  
G60**



*Model G19*

**Includes  
INSTALLATION  
USE & CARE  
PARTS LISTS  
WIRING DIAGRAMS**

### **IMPORTANT: DO NOT DISCARD THIS MANUAL**

This manual is considered to be part of the appliance and is to be given to the OWNER or MANAGER of the restaurant, or to the person responsible for TRAINING OPERATORS of this appliance. Additional manuals are available from your WELLS DEALER.

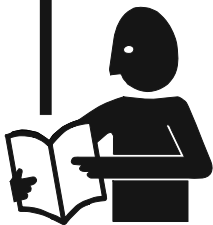

**THIS MANUAL MUST BE READ AND UNDERSTOOD BY ALL PERSONS USING OR INSTALLING THIS APPLIANCE.** Contact your WELLS DEALER if you have any questions concerning installation, operation or maintenance of this equipment.

## LIMITED WARRANTY STATEMENT

Unless otherwise specified, all commercial cooking equipment manufactured by Wells Manufacturing is warranted against defects in materials and workmanship for a period of one year from the date of original installation or 18 months from the date of shipment from our factory, whichever comes first, and is for the benefit of the original purchaser only.

THIS WARRANTY IS THE COMPLETE AND ONLY WARRANTY, EXPRESSED OR IMPLIED IN LAW OR IN FACT, INCLUDING BUT NOT LIMITED TO, WARRANTIES OF MERCHANTABILITY OR FITNESS FOR ANY PARTICULAR PURPOSE, AND/OR FOR DIRECT, INDIRECT OR CONSEQUENTIAL DAMAGES IN CONNECTION WITH WELLS BLOOMFIELD PRODUCTS. This warranty is void if it is determined that, upon inspection by an authorized service agency, the equipment has been modified, misused, misapplied, improperly installed, or damaged in transit or by fire, flood or act of God. It also does not apply if the serial nameplate has been removed, or if service is performed by unauthorized personnel. The prices charged by Wells

Manufacturing for its products are based upon the limitations in this warranty. Seller's obligation under this warranty is limited to the repair of defects without charge by a Wells Manufacturing factory authorized service agency or one of its sub-service agencies. This service will be provided on customer's premises for non-portable models. Portable models (a device with a cord and plug) must be taken or shipped to the closest authorized service agency, transportation charges prepaid, for service. In addition to restrictions contained in this warranty, specific limitations are shown in the Service Policy and Procedure Guide. Wells Manufacturing authorized service agencies are located in principal cities. This warranty is valid in the United States and Canada and void elsewhere. Please consult your classified telephone directory, your foodservice equipment dealer or contact:

**Wells Manufacturing**  
**10 Sunnen Dr., St. Louis MO 63143 USA**  
**phone (314) 678-6314 or fax (314) 781-2714**

for information and other details concerning warranty.

## SERVICE POLICY AND PROCEDURE GUIDE and ADDITIONAL WARRANTY EXCLUSIONS

1. Resetting of safety thermostats, circuit breakers, over load protectors, and/or fuse replacements are not covered by this warranty unless warranted conditions are the cause.
2. All problems due to operation at **voltages or phase other than specified on equipment nameplates are not** covered by this warranty. Conversion to correct voltage and/or phase must be the customer's responsibility.
3. All problems due to **electrical connections not made in accordance with electrical code requirements and wiring diagrams** supplied with the equipment are **not** covered by this warranty.
4. Replacement of items subject to normal wear, to include such items as knobs, light bulbs; and, normal maintenance functions including adjustments of thermostats, adjustment of micro switches and replacement of fuses and indicating lights are not covered by warranty.
5. Damage to electrical cords and/or plug due to exposure to excessive heat are **not** covered by this warranty.
6. Full use, care, and maintenance instructions supplied with each machine. Noted maintenance and preventative maintenance items, such as servicing and cleaning schedules, are customer responsibility. Those miscellaneous adjustments noted are customer responsibility. Proper attention to preventative maintenance and scheduled maintenance procedures will prolong the life of the appliance.
7. Travel mileage is limited to **sixty (60) miles** from an Authorized Service Agency or one of its sub-service agencies.
8. All labor shall be performed during regular working hours. Overtime premium will be charged to the buyer.
9. All genuine Wells replacement parts are warranted for ninety (90) days from date of purchase on non-warranty equipment. This parts warranty is limited only to replacement of the defective part(s). **Any use of non-genuine Wells parts completely voids any warranty.**
10. Installation, labor, and job check-outs are not considered warranty and are thus **not** covered by this warranty.
11. Charges incurred by delays, waiting time or operating restrictions that hinder the service technician's ability to perform service are **not** covered by warranty. This includes institutional and correctional facilities.

## SHIPPING DAMAGE CLAIM PROCEDURE

NOTE: For your protection, please note that equipment in this shipment was carefully inspected and packaged by skilled personnel before leaving the factory. Upon acceptance of this shipment, the transportation company assumes full responsibility for its safe delivery.

### IF SHIPMENT ARRIVES DAMAGED:

1. **VISIBLE LOSS OR DAMAGE:** Be certain that any visible loss or damage is noted on the freight bill or express receipt, and that the note of loss or damage is signed by the delivery person.
2. **FILE CLAIM FOR DAMAGE IMMEDIATELY:** Regardless of the extent of the damage.

3. **CONCEALED LOSS OR DAMAGE:** if damage is unnoticed until the merchandise is unpacked, notify the transportation company or carrier immediately, and file "CONCEALED DAMAGE" claim with them. This should be done within fifteen (15) days from the date the delivery was made to you. Be sure to retain the container for inspection.

Wells Manufacturing cannot assume liability for damage or loss incurred in transit. We will, however, at your request, supply you with the necessary documents to support your claim.

## TABLE OF CONTENTS

WARRANTY	xi
SPECIFICATIONS	1
FEATURES & OPERATING CONTROLS	2
PRECAUTIONS & GENERAL INFORMATION	3
AGENCY LISTING INFORMATION	4
INSTALLATION	4
OPERATION	6
CLEANING INSTRUCTIONS	
Standard and Grooved Griddles	8
Chrome-Plated griddles	9
TROUBLESHOOTING SUGGESTIONS	10
EXPLODED VIEW & PARTS LIST	11
WIRING DIAGRAM	23
PARTS & SERVICE	29
CUSTOMER SERVICE DATA	29

## INTRODUCTION

Thank You for purchasing this Wells Manufacturing appliance.

Proper installation, professional operation and consistent maintenance of this appliance will ensure that it gives you the very best performance and a long, economical service life.

This manual contains the information needed to properly install this appliance, and to use and care for the appliance in a manner which will ensure its optimum performance.

## SPECIFICATIONS

MODEL	VOLTS	WATTS	AMPS 3 $\phi$				AMPS 1 $\phi$
			L1	L2	L3	N	
G13	208/240V	6,750 / 9,000	14.0 / 18.7	28.1 / 32.5	14.0 / 18.7		32.5 / 37.5
	480	9,000	9.4	16.2	9.4		18.7
G13EU	380-415V	10,800	15	15	15	0	
G19	208V	12,000	28.8	49.9	28.8		57.6
	240V	12,000	25	43.3	25		50
	480V	12,000	12.5	21.7	12.5		25
G19EU	380-415V	16,100	22.5	22.5	22.5	0	
G23	208V	16,000	48.3	51.3	35		76.9
	240V	16,000	41.7	44.4	30.4		66.6
	208/240V	12,000 / 16,000	36.2 / 41.7	38.5 / 44.4	26.3 / 30.4		57.7 / 66.6
	480V	16,000	20.9	22.2	15.5		33.3
G23EU	380-415V	16,000	15.8	31.6	19.2	38.6	
G24	208V	21,500	63.4	67.1	45.8		103.3
	240V	21,500	55	58.3	39.6		89.5
	480V	21,500	27.1	28.9	19.9		43.8
G24EU	380-415V	21,000	20.8	41.7	25	50.6	
G60	208V	32,000	48.3	51.3	35		76.9 x 2
	240V	32,000	41.7	44.4	30.4		66.6 x 2
	480V	32,000	20.9	22	15.1		33.3 x 2

## FEATURES & OPERATING CONTROLS

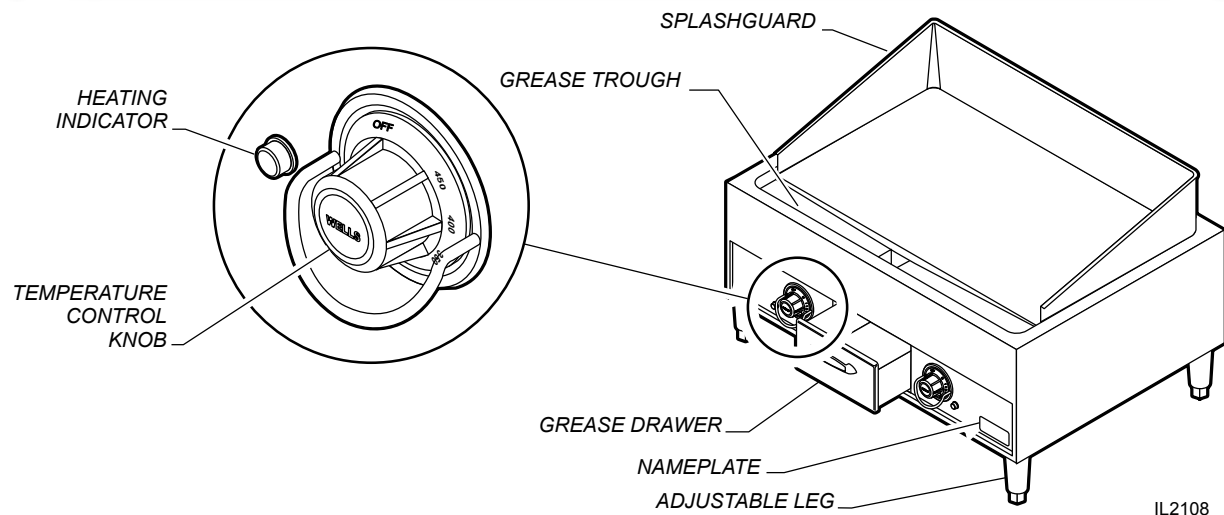

Fig. 1 Countertop Griddle Features & Operating Controls  
G19 Shown - G13, G23, G24 and G60 are Similar

Power is applied to the heating elements according to the control knob position and the actual temperature sensed at the thermobulb. When the element is energized the heating indicator will glow.

Each section of the griddle is individually controllable.

### TEMPERATURE CONTROL

Dial position is an indication of the temperature setting. The actual temperature at the griddle surface will vary, depending upon the initial type and temperature of the product, and other variables.

### GREASE TROUGH

Extra-wide trough with radiused corners for easier cleaning. Trough slopes toward a large waste hole that empties into the removable grease drawer.

### GREASE DRAWER

Large-capacity drawer is removable through the front for easy cleaning.

### REMOVABLE SPLASH GUARD

Stainless steel splash guard simplifies griddle maintenance and helps to keep grease from splattering onto adjacent walls and equipment

### ADJUSTABLE LEGS

Adjustable for use in leveling the griddle. Allow for ventilation and cleaning underneath.

### NAMEPLATE

Lists manufacturer's information, model and serial number. Also lists electrical specifications.

## PRECAUTIONS AND GENERAL INFORMATION



### **DANGER: BURN HAZARD**

Contact with cooking surface cause severe burns. Always wear protective clothing and avoid contact with griddle surface.



### **WARNING: ELECTRIC SHOCK HAZARD**

All servicing requiring access to non-insulated components must be performed by qualified service personnel. DO NOT open any access panel that requires the use of tools. Failure to heed this warning may result in severe electric shock.

This appliance is intended for use in commercial establishments only.

This appliance is intended to prepare food for human consumption. No other use is recommended or authorized by the manufacturer or its agents.

Operators of this appliance must be familiar with the appliance use, limitations and associated restrictions. Operating instructions must be read and understood by all persons using or installing this appliance.

Cleanliness of this appliance is essential to good sanitation. Read and follow all included cleaning instructions and schedules to ensure the safety of the food product.

Disconnect this appliance from electrical power before performing any maintenance or servicing.

DO NOT submerge this appliance in water. This appliance is not jet stream approved. Do not direct water jet or steam jet at this appliance, or at any control panel or wiring. Do not splash or pour water on, in or over any controls, control panel or wiring.

Exposed surfaces of this appliance can be hot to the touch and may cause burns.

The technical content of this manual, including any wiring diagrams, schematics, parts breakdown illustrations and/or adjustment procedures, is intended for use by qualified technical personnel.

Any procedure which requires the use of tools must be performed by a qualified technician.

This manual is considered to be a permanent part of the appliance. This manual and all supplied instructions, diagrams, schematics, parts breakdown illustrations, notices and labels must remain with the appliance if it is sold or moved to another location.

This appliance is made in the USA. Unless otherwise noted, this appliance has American sizes on all hardware.



### **CAUTION: RISK OF DAMAGE**

**DO NOT** connect or energize this appliance until all installation instructions are read and followed. Damage to the appliance will result if these instructions are not followed.



### **CAUTION: HOT SURFACE**

Exposed surfaces can be hot to the touch and may cause burns.

## AGENCY LISTING INFORMATION

This appliance conforms to NSF Standard 4 for sanitation only if installed in accordance with the supplied *Installation Instructions* and maintained according to the instructions in this manual.

This appliance is  Listed under UL File E6070 for 120V, 208V and 240V.



## INSTALLATION

### UNPACKING & INSPECTION

Carefully remove the appliance from the carton. Remove all protective plastic film, packing materials and accessories from the appliance before connecting electrical power or otherwise performing any installation procedure.

Carefully read all instructions in this manual and the *Installation Instruction Sheet* packed with the appliance before starting any installation.

Read and understand all labels and diagrams attached to the appliance.

Carefully account for all components and accessories before discarding packing materials. Store all accessories in a convenient place for later use.

### COMPONENTS

- 1 ea. GREASE DRAWER (2 ea. for G-60)
- 1 ea. SCRAPER (for grooved griddle plates, if ordered)
- 1 ea. SPLASHGUARD
- 4 ea. ADJUSTABLE LEGS (6 ea. for G-60)

### SETUP

Setup the appliance only on a firm, level, non-combustible surface. Verify local codes for requirements. Concrete, tile, terrazzo or metal surfaces are recommended. Metal over combustible material may not meet code for non-combustible surfaces.

Install one adjustable leg at each corner of the griddle by screwing the leg into the fitting on the bottom. For G60, also screw one leg into each center position. With a spirit level, check that the appliance is level front-to-back and side-to-side. Verify that the unit sits firmly ON ALL FOUR LEGS.

The lower portions of the legs are adjustable by turning; adjust as required to level the appliance. All legs must be adjusted to firmly contact the counter in order to prevent tipping.

Refer to the *Installation Instruction Sheet* for required clearances. Maintain required clearances between the appliance and adjacent combustible surfaces.

Avoid storing flammable or combustible materials on or near the appliance.

**NOTE:** DO NOT discard the carton or other packing materials until you have inspected the appliance for hidden damage and tested it for proper operation. Refer to *SHIPPING DAMAGE CLAIM PROCEDURE* on the inside front cover of this manual.

**IMPORTANT:** This installation must comply with all applicable Federal, Local and NFPA codes.

SCREW INTO CABINET  
MOUNTING HOLES



TURN TO  
ADJUST HEIGHT

Fig. 2 Adjustable Legs

## INSTALLATION (continued)



### **WARNING: ELECTRIC SHOCK HAZARD**

All servicing requiring access to non-insulated electrical components must be performed by a factory authorized technician.  
DO NOT open any access panel which requires the use of tools. Failure to follow this warning can result in severe electrical shock.

### **ELECTRICAL INSTALLATION**

Refer to the nameplate. Verify the electrical service power. Voltage and phase must match the nameplate specifications. Connecting the griddle to the wrong voltage can severely damage the unit or cause noticeably decreased performance.

**IMPORTANT:** Damage due to being connected to the wrong voltage is NOT covered by warranty.

Use copper wire suitable for at least 90°C for supply connections.

Griddles are factory wired three-phase (3Ø).

For single-phase (1Ø) wiring, refer to the wiring diagram attached to the griddle.

This griddle is not fused. Protect the circuit with properly sized fuses or circuit breaker.

An electrical disconnect must be installed readily accessible to the operator of the griddle.

### **EQUIPMENT SETUP**

Install splashguard. Notches on front wings lock into exposed studs in grease trough.

Slide grease drawer into grease drawer sleeve in front of griddle.



### **CAUTION: RISK OF DAMAGE**

DO NOT connect or energize this appliance until all installation instructions are read and followed. Damage to the appliance will result if these instructions are not followed.



### **CAUTION: ELECTRICAL SHOCK HAZARD**

This griddle must be electrically grounded.

Connect the terminal marked "GND" or "⊥" to a suitable building ground.

### **IMPORTANT:**

Damage due to being connected to the wrong voltage or phase is NOT covered by warranty.

## OPERATION



### **CAUTION: HOT SURFACE**

Exposed surfaces can be very hot and may cause severe burns on contact.

### **IMPORTANT:**

SCRATCHES WILL DAMAGE THE SURFACE OF CHROME-PLATED GRIDDLES.

DO NOT use anything on chrome griddle that could scratch the surface.

DO NOT clean chrome surface with griddle bricks, pumice stone or abrasive cleansers.

### **PREPARING THE GRIDDLE SURFACE SEASONING STANDARD AND GROOVED GRIDDLES**

As manufactured, the steel surface of your Wells griddle has microscopic pores. It is important to fill these pores with oil in order to provide a hard, non-stick cooking surface.

- a. Preheat griddle surface to 375°F (191°C).
- b. Spread a light film of cooking oil over entire griddle surface.
- c. Allow oil film to “cook in” for approximately 2 minutes, or until it smokes.
- d. Wipe griddle surface with clean damp cloth to remove all oil.
- e. For new griddles, repeat this procedure 2-3 times until griddle has a slick, clean surface.

### **CHROME PLATED GRIDDLES**

Because the microscopic pores in the griddle surface are filled by the chrome plating, no seasoning of the griddle surface is required.

- a. Thoroughly clean griddle surface using a soft clean cloth and a small amount of mild detergent.
- b. Rinse and dry thoroughly after cleaning.
- c. The griddle is now ready to use.

### **USING THE GRIDDLE**

Check the chart on page 7 for recommended cooking temperatures. Turn temperature control knob to the desired temperature. The heating indicator light will glow while the griddle is heating. When the indicator light first goes out, griddle is ready to use.

For standard griddles:

- Keep the griddle surface clean and well oiled during use.
- Scrape cooking waste into the grease trough frequently during use.
- Occasionally brush or spray a light coat of cooking oil on the griddle surface in order to maintain the non-stick surface.

For chrome plated griddles:

- Scrape cooking waste into the grease trough after preparing each order.
- DO NOT bang or tap pots, pans, spatulas or other metal utensils on the griddle surface as this may damage the chrome plating.

### **NOTE:**

Separate sections of griddle may be set to different temperatures. This will allow a variety of products to be prepared at the same time, and will allow prepared product to be held at serving temperature after cooking.

For best results, different temperatures should be set from coolest to hottest sequentially across the width of the griddle. (Heat will migrate over the entire griddle surface. Setting one section low, adjacent to a section set high, may overwork components in the “high” section as the thermostat tries to compensate for heat lost to the “low” section.)



## OPERATION (continued)

### RECOMMENDED GRILLING TIMES AND TEMPERATURES

PRODUCT	TEMP		TIME
	°F	°C	
Bacon	350°	176°C	2 - 3 minutes
Beef Tenderloin	400°	204°C	3 - 4 minutes
Broiled Ham	375°	190°C	2 minutes
Canadian Bacon	350°	176°C	2 - 3 minutes
Cheeseburgers	350°	176°C	3 - 4 minutes
Club Steak, 1" thick	400°	204°C	3 - 5 minutes
Ham Steaks	375°	190°C	3 - 4 minutes
Hamburgers	350°	176°C	3 - 4 minutes
Hot Dogs	325°	162°C	2 - 3 minutes
Melted Cheese Sandwich	375°	190°C	3 - 4 minutes
Minute Steaks	400°	204°C	3 - 4 minutes
Sausage, link and patty	350°	176°C	3 minutes

#### NOTE:

The times and temperatures in this chart are suggestions only.

Your own experience with your own menu items will be your best guide to achieving the best food product.

## CLEANING INSTRUCTIONS - STANDARD AND GROOVED GRIDDLES



### CAUTION: BURN HAZARD

Griddle will be hot during portions of this cleaning procedure. Always heat-protective gloves and apron.



### CAUTION: ELECTRIC SHOCK HAZARD

Do not submerge griddle in water.

**IMPORTANT: DO NOT** spill or pour water into controls, control panel or wiring.

**DO NOT** submerge griddle in water. Damage to internal components will occur. Damage to internal components from water damage is **not** covered by warranty.

**IMPORTANT: NEVER USE STEEL WOOL TO CLEAN THE GRIDDLE SURFACE!**

**DO NOT** use detergent or oven cleaner to clean the griddle surface.

**IMPORTANT: DO NOT** use steel wool or abrasive cleansers for cleaning the griddle cabinet.

### PREPARATION

Set temperature control to 220°F. Allow griddle temperature to drop to 220°F before proceeding.

### FREQUENCY

Daily

### TOOLS

Griddle Brick or Pumice Stone, Fiber Brush  
Plastic Scouring Pad, Plastic Scraper  
Contoured Scraper (grooved griddle)  
Mild Detergent, Non-Abrasive Cleanser  
Clean Soft Cloth / Sponge

### CLEANING

Pour a small amount of water on the griddle surface and let it “sizzle”.

Clean the griddle surface:

- For standard griddles, use a pumice stone or griddle brick to scrape food waste. Clean the griddle surface down to bright metal. Wipe off any remaining powder residue.
- For grooved-surface griddles, use the supplied contoured scraper to scrape food waste. Clean the griddle surface down to bright metal.

Use a soft-bristled fiber brush in a circular motion to remove any remaining food particles.

Turn temperature control to OFF. Allow the griddle surface to cool, then wipe the surface with a clean cloth. Dry the griddle surface thoroughly.

**IMPORTANT: SEASON THE COOKING SURFACE AFTER EACH CLEANING.** Refer to page 6.

At least once each day, the grease trough must be thoroughly cleaned. Using a scraper, remove all grease and food waste from the grease trough by pushing it down the waste hole and into the grease drawer.

After scraping all cooking waste from grease trough into the grease drawer, take the grease drawer to kitchen cleaning area and properly dispose of all waste.

- Clean drawer with hot water and a mild detergent.
- Dry drawer thoroughly and reinstall in griddle.

Clean the splash guard in the sink with warm water and mild detergent, or in the dishwasher. Rinse thoroughly and reinstall.

Wipe down exterior of griddle cabinet with a clean cloth and non-abrasive cleanser. Rinse thoroughly with water and a clean cloth. Dry with a soft clean cloth

Procedure is complete.

## CLEANING INSTRUCTIONS - CHROME PLATED GRIDDLES

### PREPARATION

Set temperature control to 220°F. Allow griddle temperature to drop to 220°F before proceeding.

### FREQUENCY

Daily

### TOOLS

4" Razor-Style Scraper, Soft Bristle Brush  
Mild Detergent, Non-Abrasive Cleanser  
Clean Soft Cloth / Sponge



### CAUTION: BURN HAZARD

Griddle will be hot during portions of this cleaning procedure.  
Always heat-protective gloves and apron.

### CLEANING

Pour a small amount of water on the griddle surface and let it "sizzle".

Use a 4" razor-style scraper to clean the remaining food particles from the griddle surface

**IMPORTANT:** NEVER USE GRIDDLE BRICKS, PUMICE STONES OR STEEL WOOL TO CLEAN THE GRIDDLE SURFACE!

DO NOT use detergent or oven cleaner to clean griddle surface.

**IMPORTANT:** NEVER BANG OR TAP METAL IMPLEMENTS, SPATULAS, POTS, PANS, OR SCRAPERS ON THE GRIDDLE SURFACE!

Use a soft-bristled fiber brush in a circular motion to remove any remaining food particles.

Turn temperature control to OFF. Allow the griddle surface to cool, then wipe the surface with a clean cloth. Dry the griddle surface thoroughly.

At least once each day, the grease trough must be thoroughly cleaned. Using a scraper, remove all grease and food waste from the grease trough by pushing it down the waste hole and into the grease drawer.

After scraping all cooking waste from grease trough into the grease drawer, take the grease drawer to kitchen cleaning area and properly dispose of all waste.

- a. Clean drawer with hot water and a mild detergent.
- b. Dry drawer thoroughly and reinstall in griddle.

Clean the splash guard in the sink with warm water and mild detergent, or in the dishwasher. Rinse thoroughly and reinstall.

Wipe down exterior of griddle cabinet with a clean cloth and non-abrasive cleanser. Rinse thoroughly with water and a clean cloth. Dry with a soft clean cloth

Procedure is complete.



### CAUTION: ELECTRIC SHOCK HAZARD

Do not submerge griddle in water.

**IMPORTANT:** DO NOT spill or pour water into controls, control panel or wiring.

**DO NOT** submerge griddle in water. Damage to internal components will occur. Damage to internal components from water damage is **not** covered by warranty.

**IMPORTANT:** DO NOT use griddle bricks, steel wool or abrasive cleansers to clean chrome-plated cooking surface.

**IMPORTANT:** DO NOT use steel wool or abrasive cleansers for cleaning the griddle cabinet .

### IMPORTANT:

Never bang or tap metal implements, spatulas, pots, pans or scrapers on the griddle surface.

## TROUBLESHOOTING SUGGESTIONS

DESCRIPTION	POSSIBLE PROBLEM	SUGGESTED REMEDY
Griddle will not heat	Circuit breaker off or tripped	Reset circuit breaker
One section does not heat	Temperature control knobs not set to desired temperature	Set to desired temperature
	Damaged internal component	Contact Wells Authorized Service Agency for repairs
Griddle drips grease	Grease drawer full or not installed	Empty grease drawer. Install properly
	Damaged internal component	Contact Wells Authorized Service Agency for repairs

**NOTE:** There are no user serviceable components in the griddle. In all cases of damage or malfunction, contact your Authorized Wells Service Agency for repairs.

# EXPLODED VIEW & PARTS LIST

## FIELD CONVERSION FROM 3-PHASE TO SINGLE-PHASE

Griddles are shipped from the factory wired for 3-phase power, 208 volt and 240 volt griddles are field convertible to single-phase.

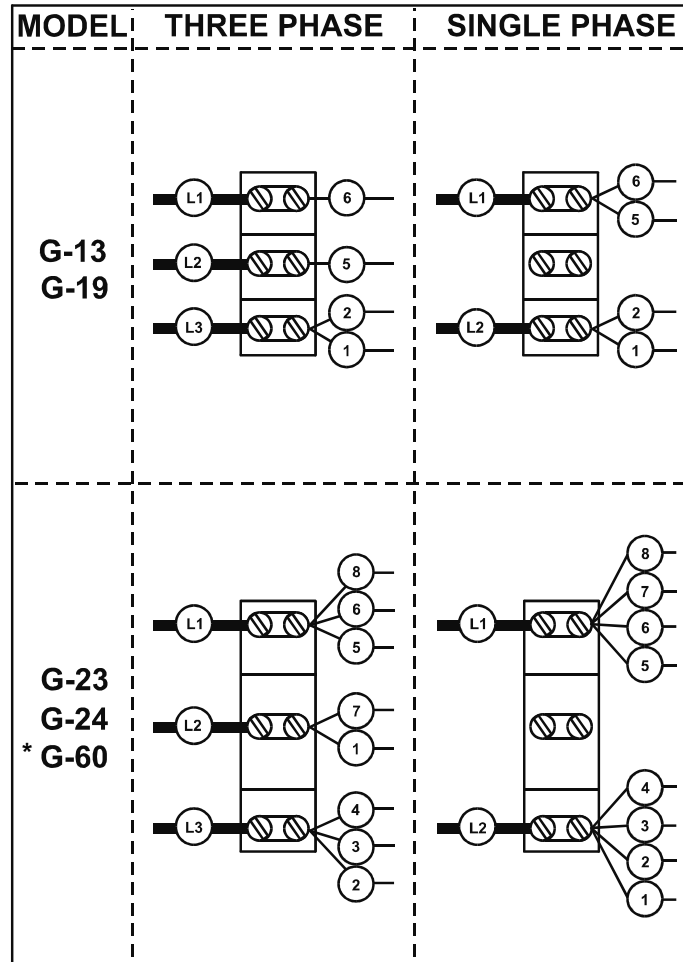

**\*NOTE:** G60 has 2 separate electrical supplies

### CONTROL KNOB CONFIGURATION

For all models, control knob p/n 2R-30259 is marked in degrees Fahrenheit from 200°F to 450°F. When the thermostat is OFF, the flat of the control shaft is positioned on the bottom.

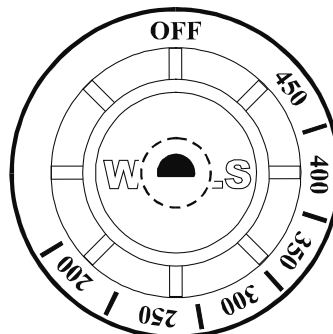

2R-30259

# EXPLODED VIEW & PARTS LIST

## COUNTERTOP ELECTRIC GRIDDLE MODEL G13, PG13 - HEATING ELEMENTS 208/240V and 480V

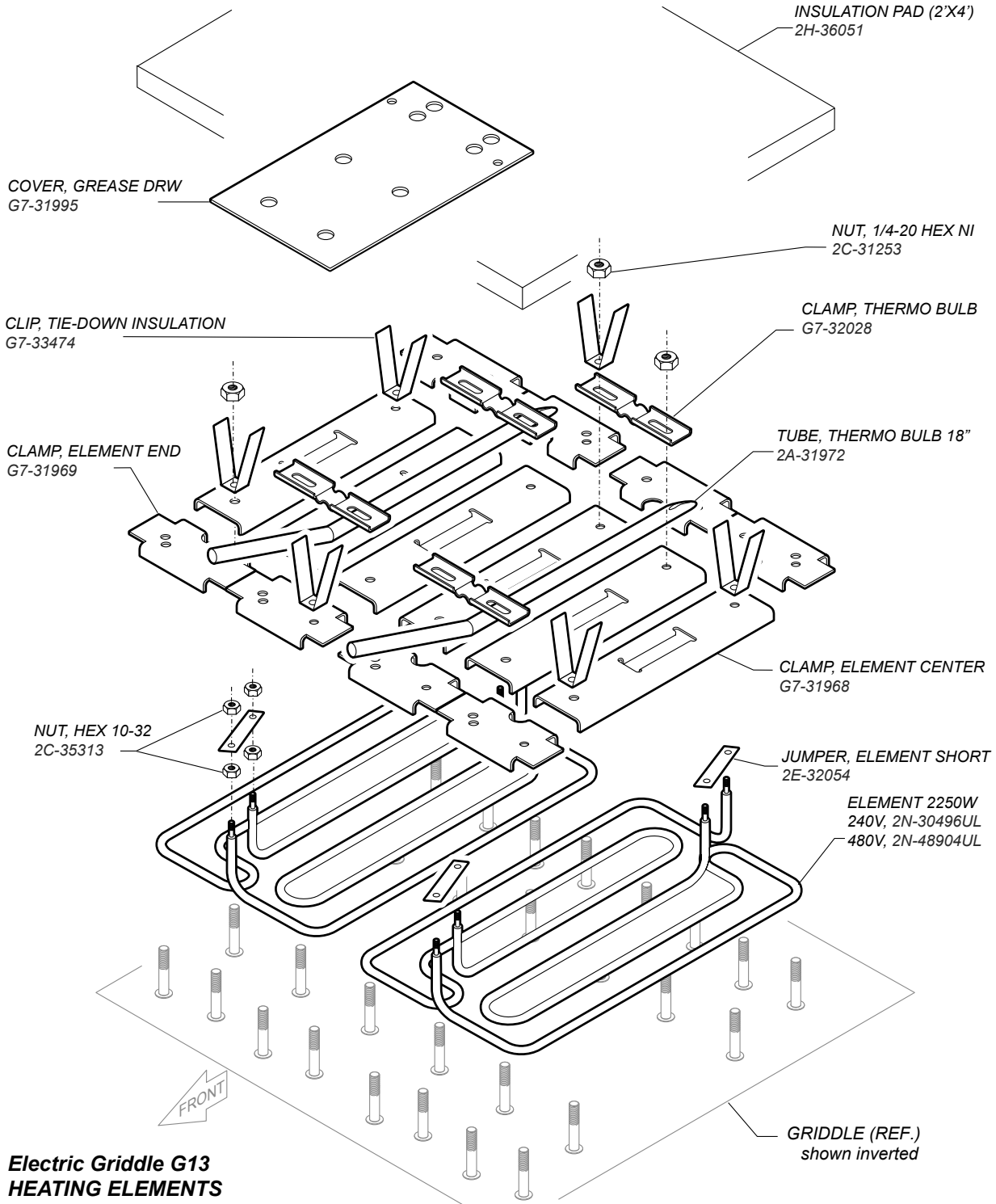

**Electric Griddle G13  
HEATING ELEMENTS  
208/240V 1Ø**

IL1918, Rev. A

# EXPLODED VIEW & PARTS LIST

## COUNTERTOP ELECTRIC GRIDDLE MODEL G13, PG13 - CABINET & ELECTRICAL 208/240V and 480V

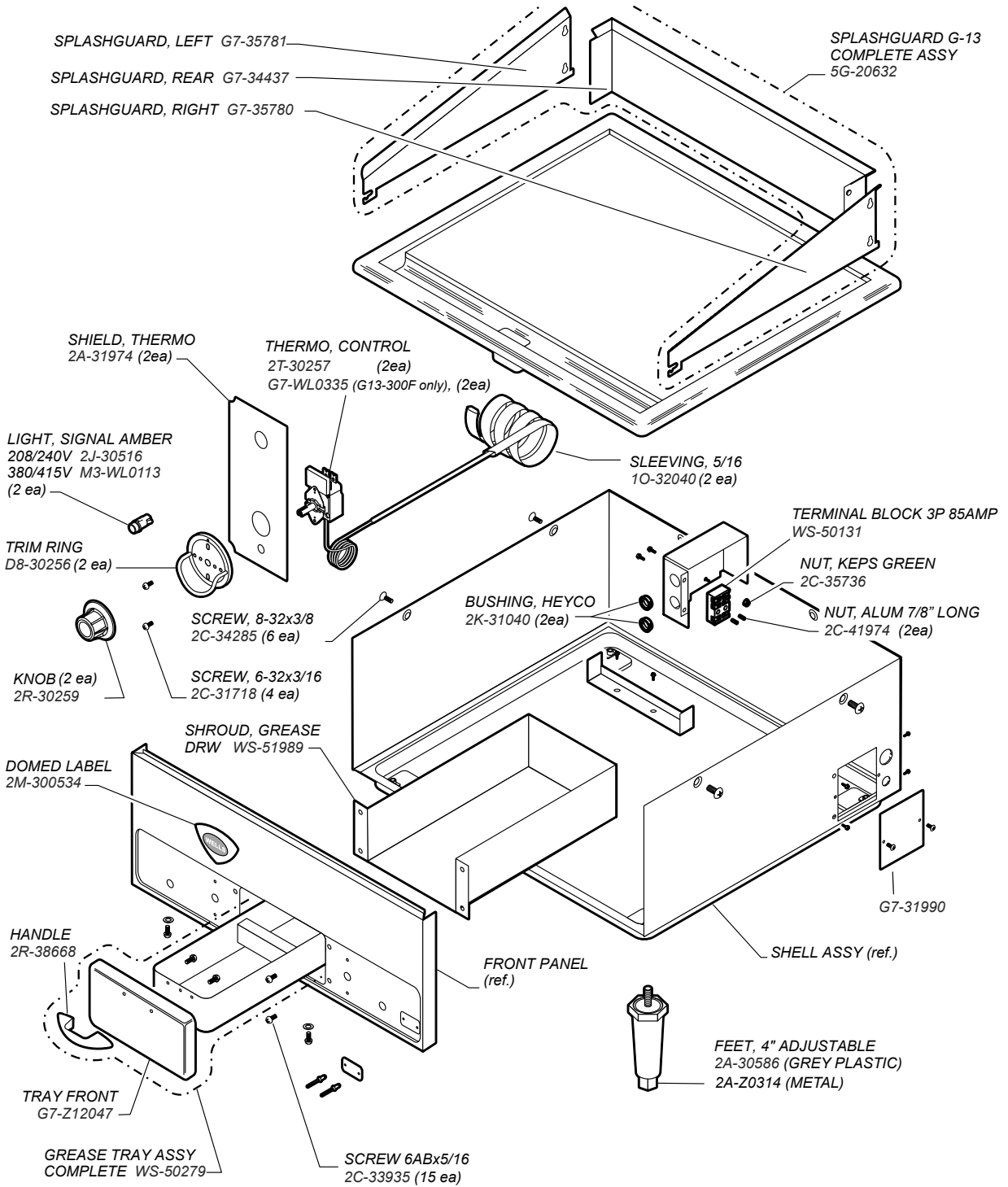

101 p/n 2M-303339 OpManual Countertop Electric Griddles

### Electric Griddle G13, PG13 CABINET COMPONENTS 208/240V 1ø

IL1917, Rev G, 2/24/15

# EXPLODED VIEW: G19

**COUNTERTOP ELECTRIC GRIDDLE  
MODEL G19 - HEATING ELEMENTS**  
208V, 240V, 380-415V and 480V

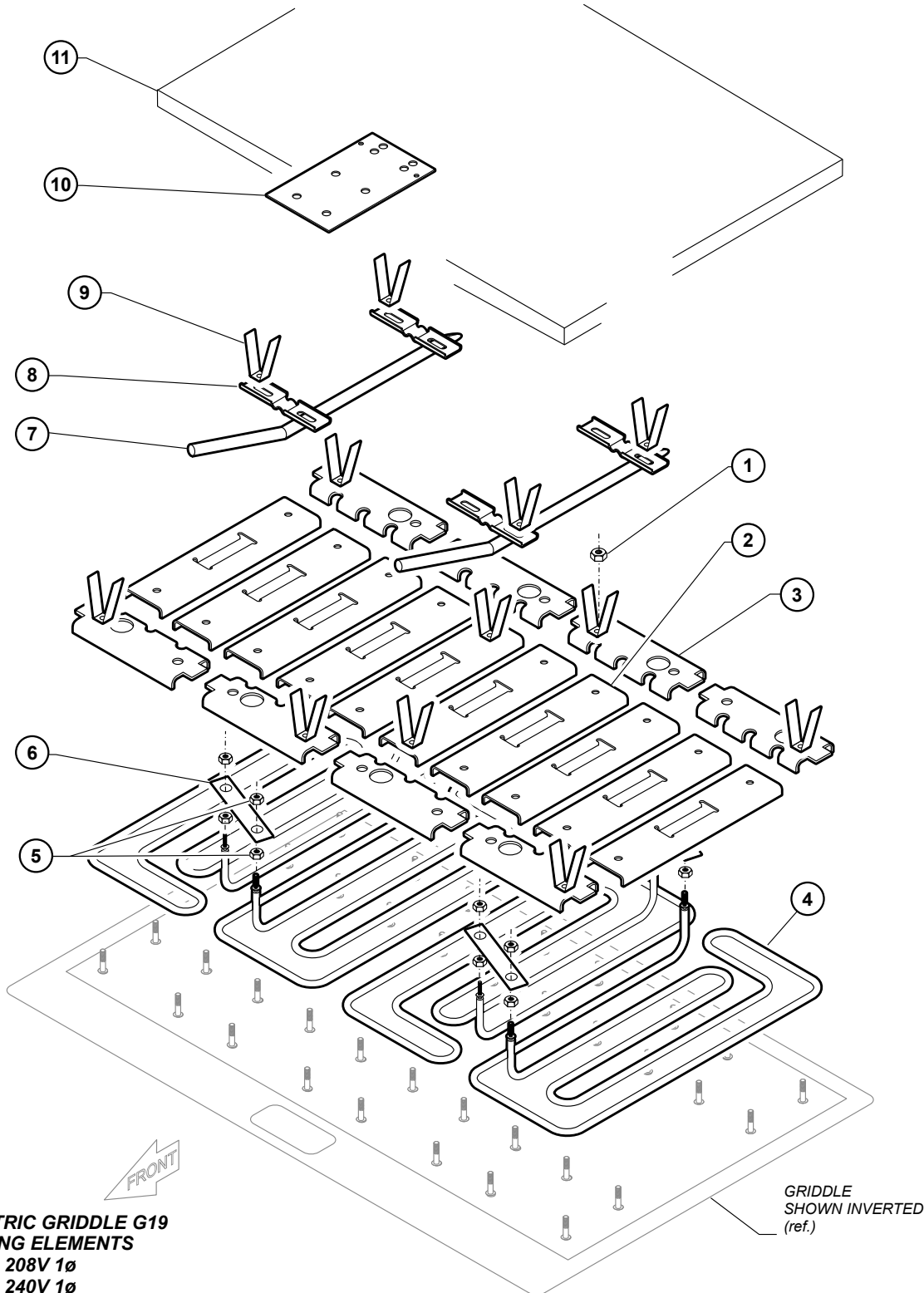



# EXPLODED VIEW: G19

**COUNTERTOP ELECTRIC GRIDDLE  
MODEL G19 - CABINET & ELECTRICAL  
208V, 240V, 380-415V and 480V**

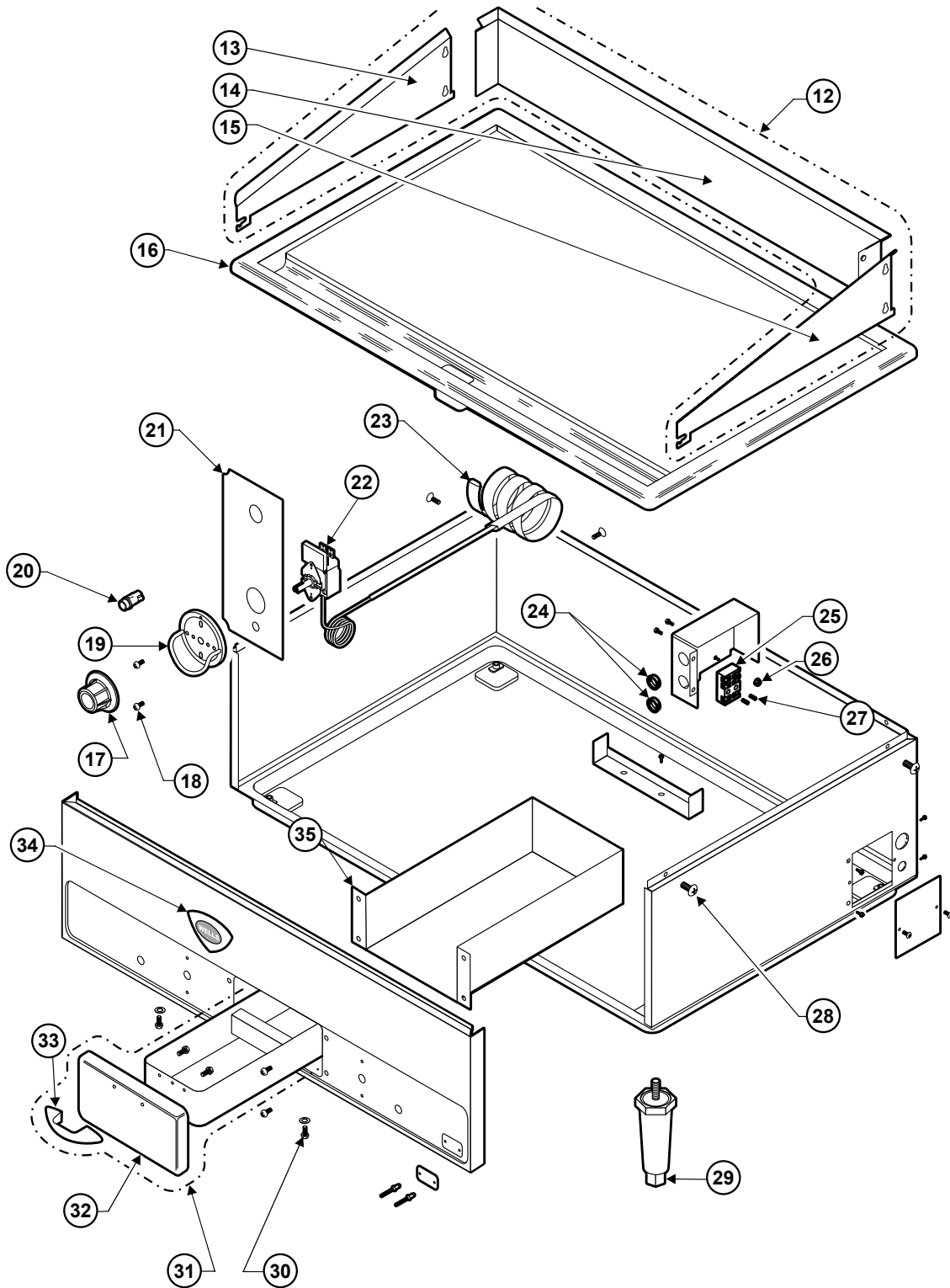

101 p/n 2M-303339 OpManual Countertop Electric Griddles

**ELECTRIC GRIDDLE G19  
CABINET COMPONENTS**

IL1920, Rev C

**PARTS LIST: G19 208V, 240V, 380-415V and 480V**

<b>G19 COUNTERTOP ELECTRIC GRIDDLE</b>				
Fig No	Part No	Qty	Description	Application
1	2C-31253	AR	NUT 1/4-20 FINISHED HEX	
2	G7-31968	10	CLAMP ELEM CTR SMALL GRID	
3	G7-32038	8	CLAMP ELEM END LRG GRID	
	G7-46169	3	CLAMP ELEM EU ROHS	380/415V
4	2N-30511UL	4	ELEM 208V 3000W	208V
	2N-30512UL	4	ELEM 240V 3000W	240V
	2N-45922UL	3	ELEM 220V 4500 EU	380/415V
	2N-48902UL	4	ELEM HEATING 480V 3000W	480V
5	2C-35313	8	NUT 10-32 HEX MS SS	208/240/480V
6	2E-32055	4	JUMPER, ELEMENT LONG	208V, 240V, 480V
7	2A-31972	2	TUBE THERMOW 18 LINE GRID	
8	G7-32028	4	CLAMP THERMO BULB GRIDDLE	
	G7-46178	3	CLAMP THERMO BULB GRIDL EU	380/415V
9	G7-33474	11	CLIP TIE DOWN INSUL GRIDDLE	
		12		380/415V
10	G7-31995	1	COVER GREASE DRWR	
	G7-46180		CVR GREASE DRWR	380/415V
11	2H-36051	6	INSUL FG 1X24X48	
12	WS-20634	1	SPLASHGUARD G-196	
13	G7-35781	1	SPLASHGUARD LF GRVD 24IN	
14	G7-34436	1	SPLASHGUARD REAR ASSY	
15	G7-35780	1	SPLASHGUARD RT GRVD 24IN	
16	CALL FACTORY	1	G19, GRIDDLE ASSY	
17	2R-30259	2	KNOB CONTROL ASSY	
	2R-46164	3	KNOB THERMO JG246EU	380/415V
18	2C-31718	AR	SCREW 6-32X3/16 PH RD HD	
19	D8-30256	2	TRIM RING ASSY	
		3		380/415V
20	2J-30516	2	LIGHT SIGNAL AMBER	208V, 240V
	M3-WL0113	2	ASSY, PILOT LIGHT ABMER	480V
		3		380/415V
21	2A-31974	2	SHIELD THERMO GRID	
		3		380/415V
22	2T-46162	3	THERMO JG246EU	380/415V
	2T-30257	2	T-STAT, 450°F, W/HARDWARE	
23	IO-32040	6FT	SLEEVING GLASS 5/16 I.D.	
24	2K-31040	2	BUSHIGN HEYCO 7/8 O.D.	
25	2E-40310	1	TERM BLOCK 4 POLE 75AMP	380/415V
	WS-50131		TERM BLOCK 3 POLE 85AMP	208V, 240V, 480V
26	2C-35736	AR	NUT 8-32 HEX KEPS MS GREEN	
27	2C-41974	2	NUT 8-32 HEX 7/8 LONG ALU	
28	2C-34285	AR	SCREW 8-32X3/8 PH	
29	2A-30586	4	BLK PLASTIC LEF, 4 INCH	
	2A-Z0314		FOOT, 4" DIE CAST	380/415V
30	2C-33935	AR	SCREW 6ABX5/16 PH PAN SMS	
31	WS-50279	1	DRAWER GREASE W/HANDLE	
32	G7-Z12047	1	PANEL FRONT - GREASE DR	
33	2R-38668	1	HANDLE DOOR	
34	2M-300534	1	TRADEMARK DOMES LABEL	
35	WS-51989	1	SHROUD GREASE DRAWER	
NI	2K-300102	1	STRAIN RELIEF 1NPT .375-1	380/415V

# EXPLODED VIEW & PARTS LIST: G23

## COUNTERTOP ELECTRIC GRIDDLE MODEL G23 - HEATING ELEMENTS 208V, 240V and 480V

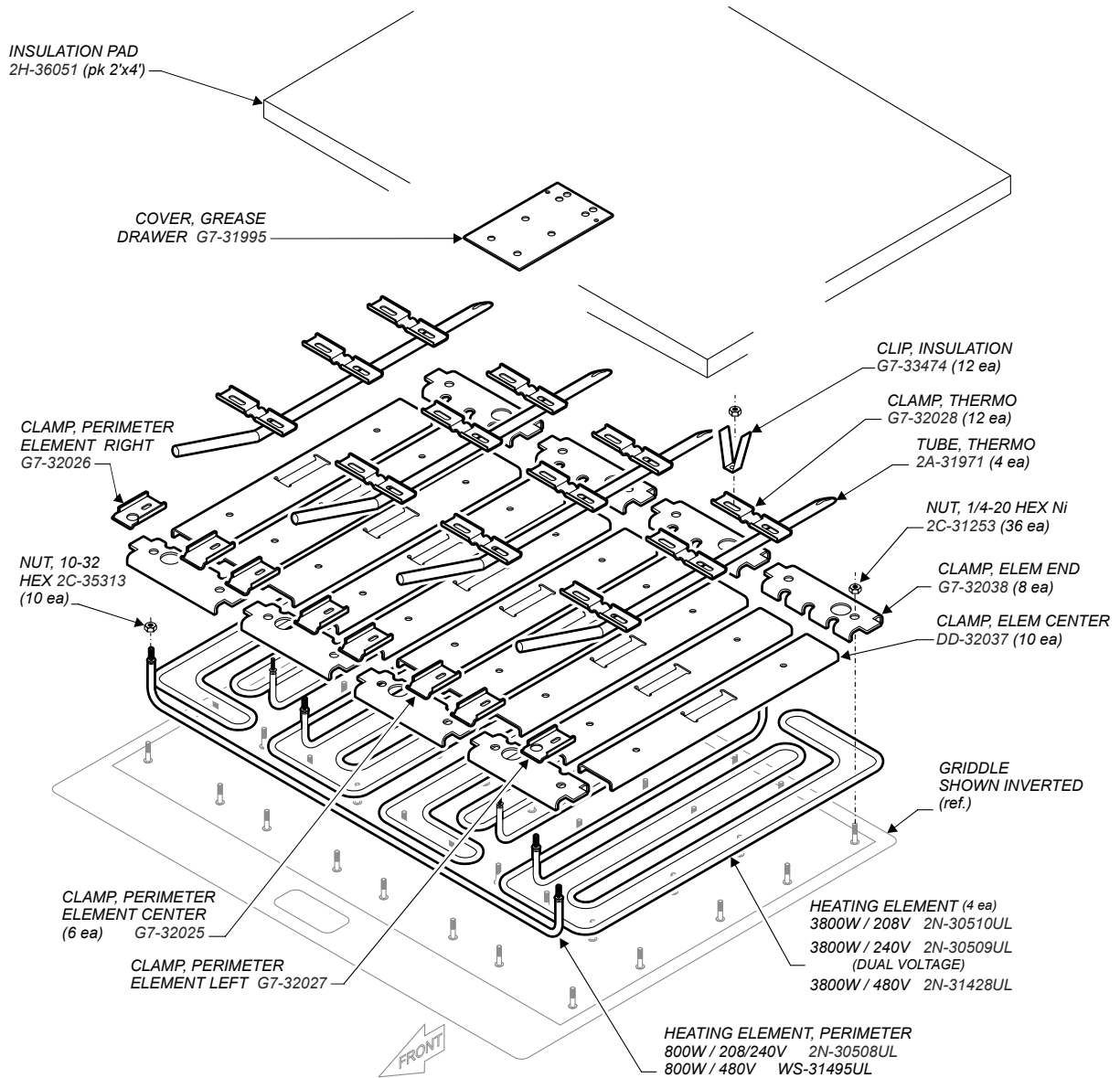

101 p/n 2M-303339 OpManual Countertop Electric Griddles

**ELECTRIC GRIDDLE G23  
HEATING ELEMENTS  
20068 208V  
20070 240V**

IL1921, Rev A

# EXPLODED VIEW & PARTS LIST

## COUNTERTOP ELECTRIC GRIDDLE MODEL G23 - CABINET & ELECTRICAL 208V, 240V and 480V

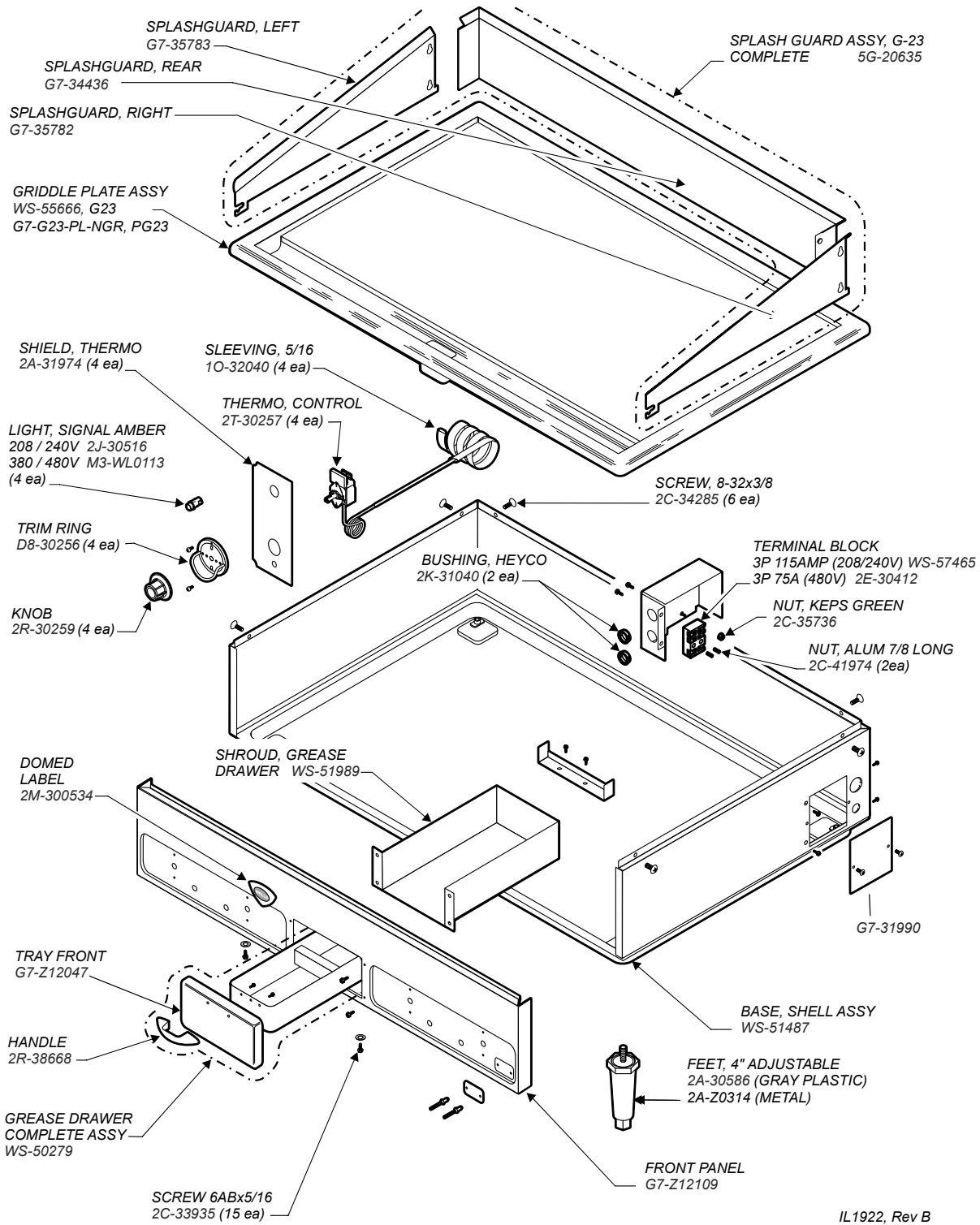

### ELECTRIC GRIDDLE G23, PG23 CABINET COMPONENTS

IL1922, Rev B

# EXPLODED VIEW & PARTS LIST

## COUNTERTOP ELECTRIC GRIDDLE MODEL G24 - HEATING ELEMENTS 208V, 240V and 480V

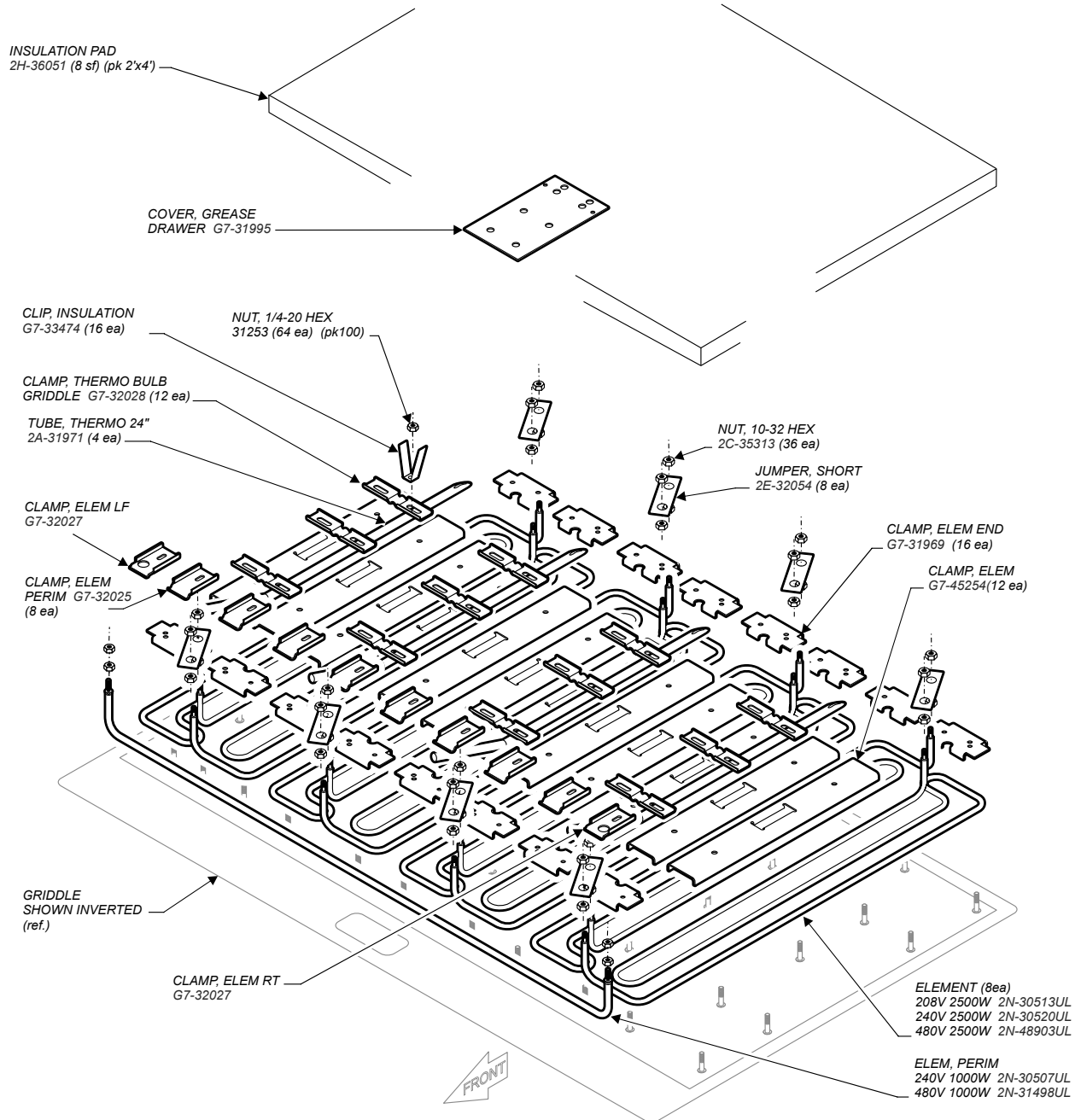

**ELECTRIC GRIDDLE G24 & PG24  
HEATING ELEMENTS**  
20076 208V  
20078 240V  
22018 480V

IL1923, Rev A

# EXPLODED VIEW & PARTS LIST

## COUNTERTOP ELECTRIC GRIDDLE MODEL G24 - CABINET & ELECTRICAL 208V, 240V and 480V

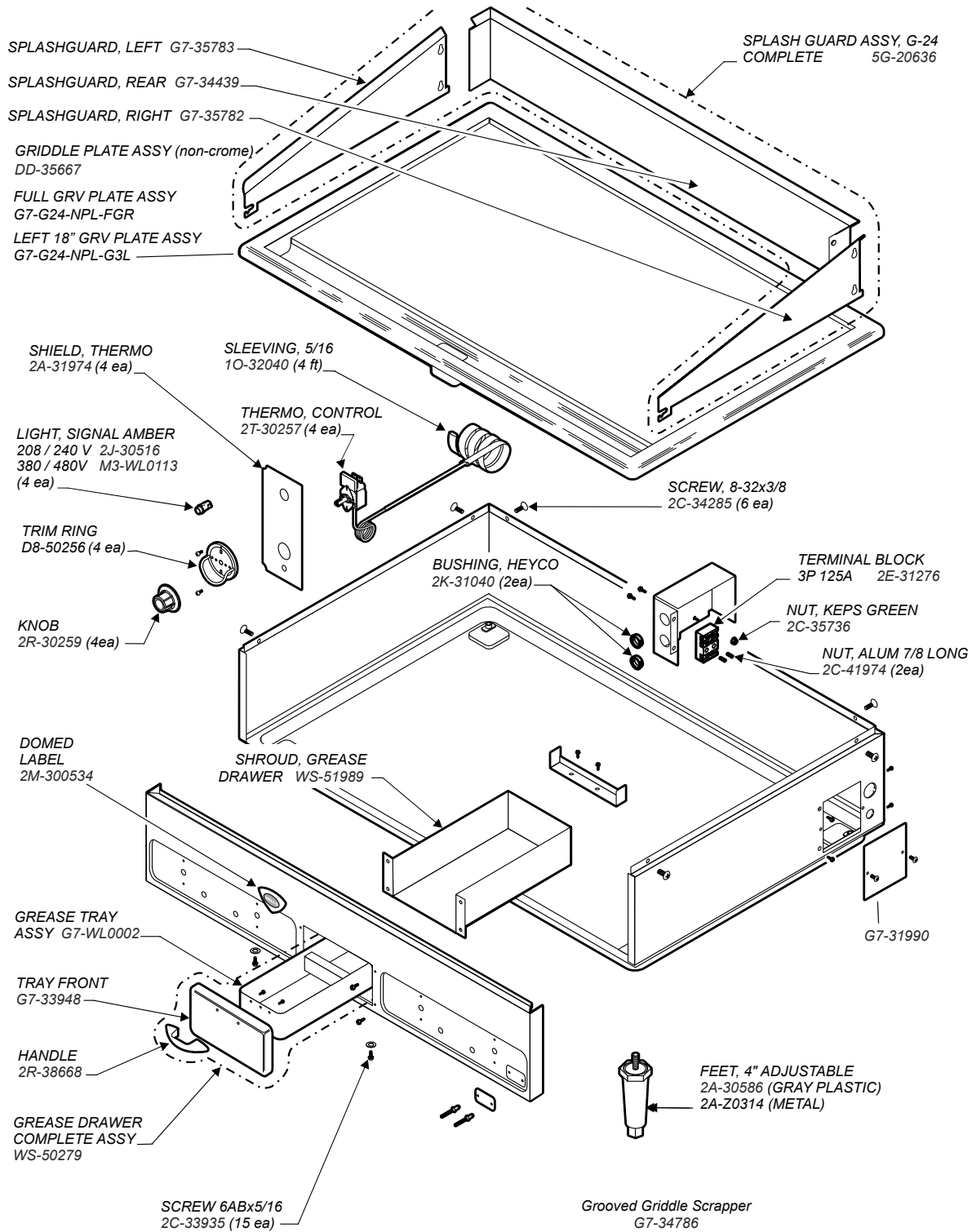

**ELECTRIC GRIDDLE G24, GG24 & PG24  
CABINET COMPONENTS**

IL1924, Rev C

# EXPLODED VIEW & PARTS LIST

## COUNTERTOP ELECTRIC GRIDDLE MODEL G60 - HEATING ELEMENTS 208V, 240V and 480V

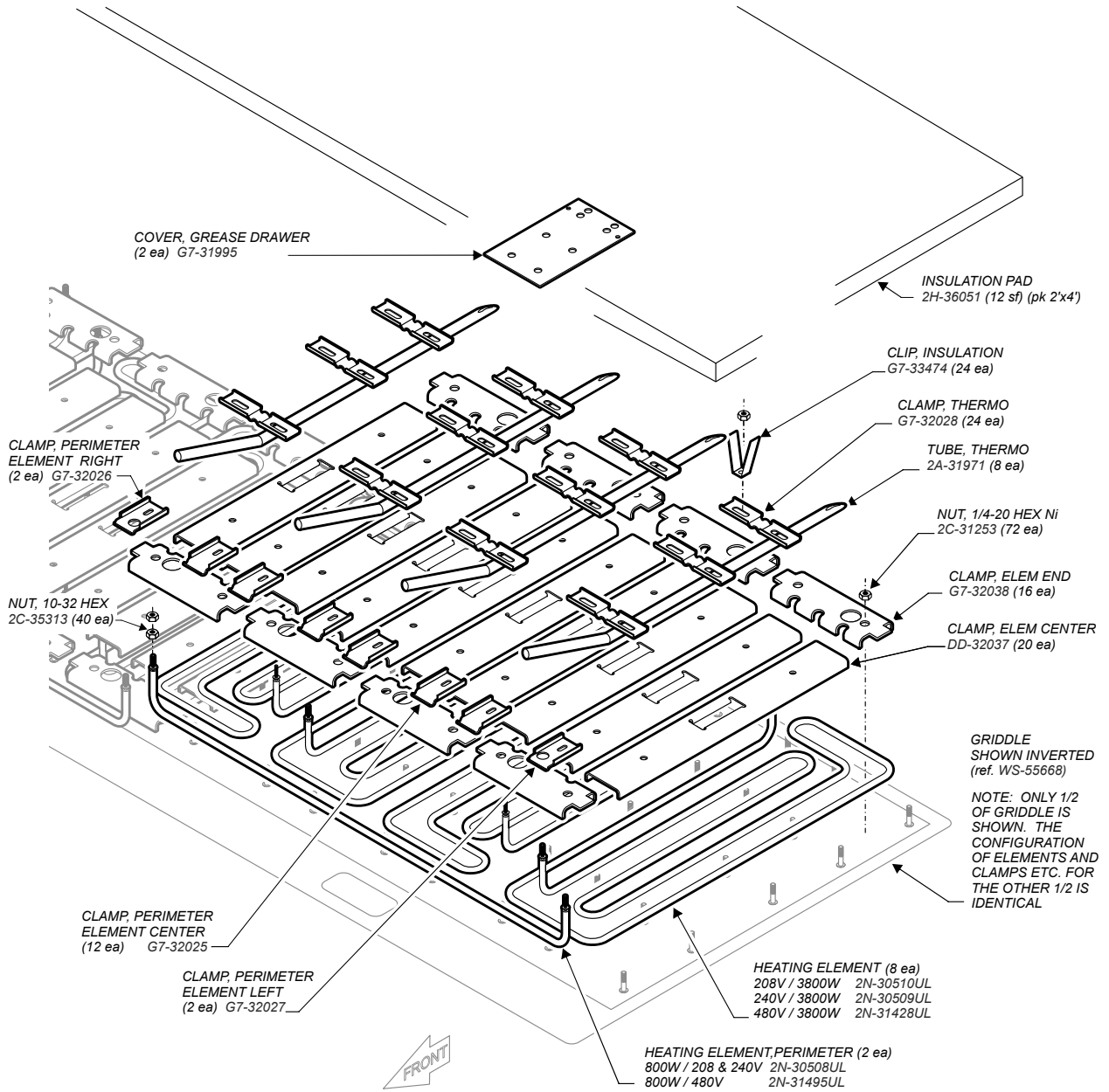

101 p/n 2M-303339 OpManual Countertop Electric Griddles

**ELECTRIC GRIDDLE G60  
HEATING ELEMENTS**  
91164 208V  
91165 240V  
91166 480V

IL1925, Rev A

# EXPLODED VIEW & PARTS LIST

## COUNTERTOP ELECTRIC GRIDDLE MODEL G60 - CABINET & ELECTRICAL 208V, 240V and 480V

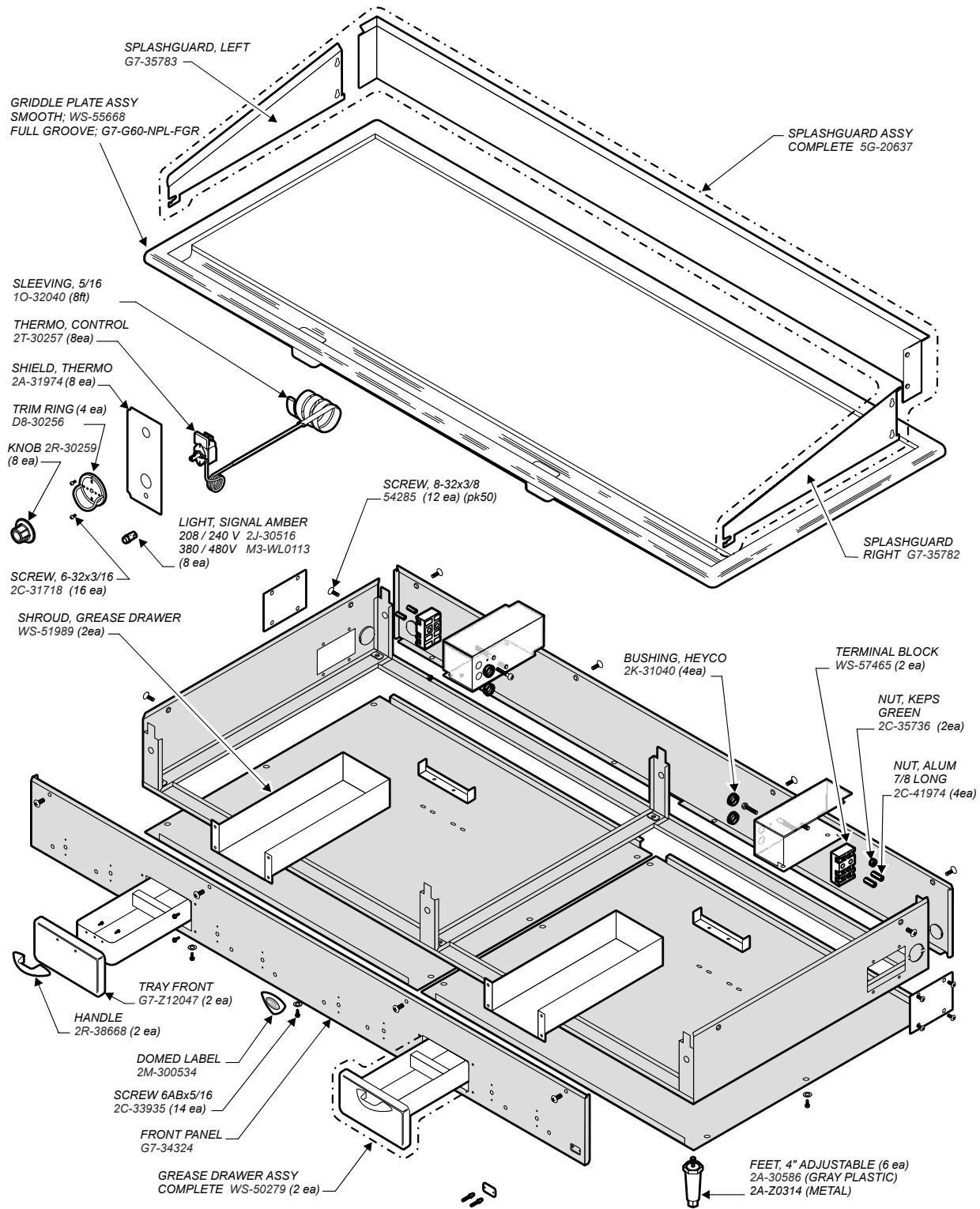

**ELECTRIC GRIDDLE G60  
CABINET COMPONENTS**

Grooved Griddle Scraper  
G7-34786

IL1926, Rev B



# WIRING DIAGRAM

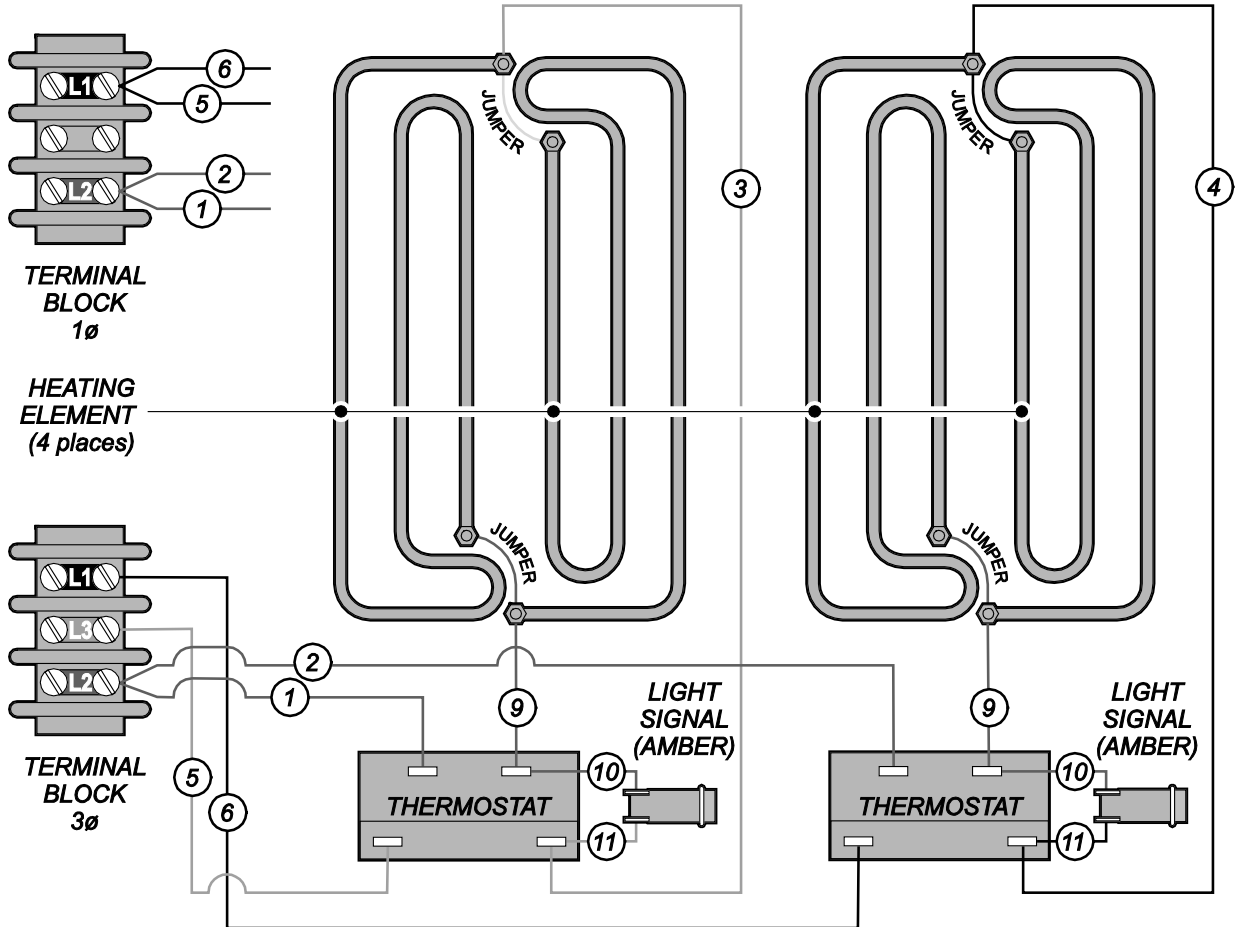

## G-13 and G-136 208V 240V 480V

p/n 48929 issue C

VOLTS	KW	NOMINAL AMPS PER LINE			
		AMPS 3Ø			AMPS 1Ø
		L1	L2	L3	
208	6.8	14.0	28.1	14.0	32.5
240	9.0	18.7	32.5	18.7	37.5
480	9.0	9.4	16.2	9.4	18.7

# WIRING DIAGRAM

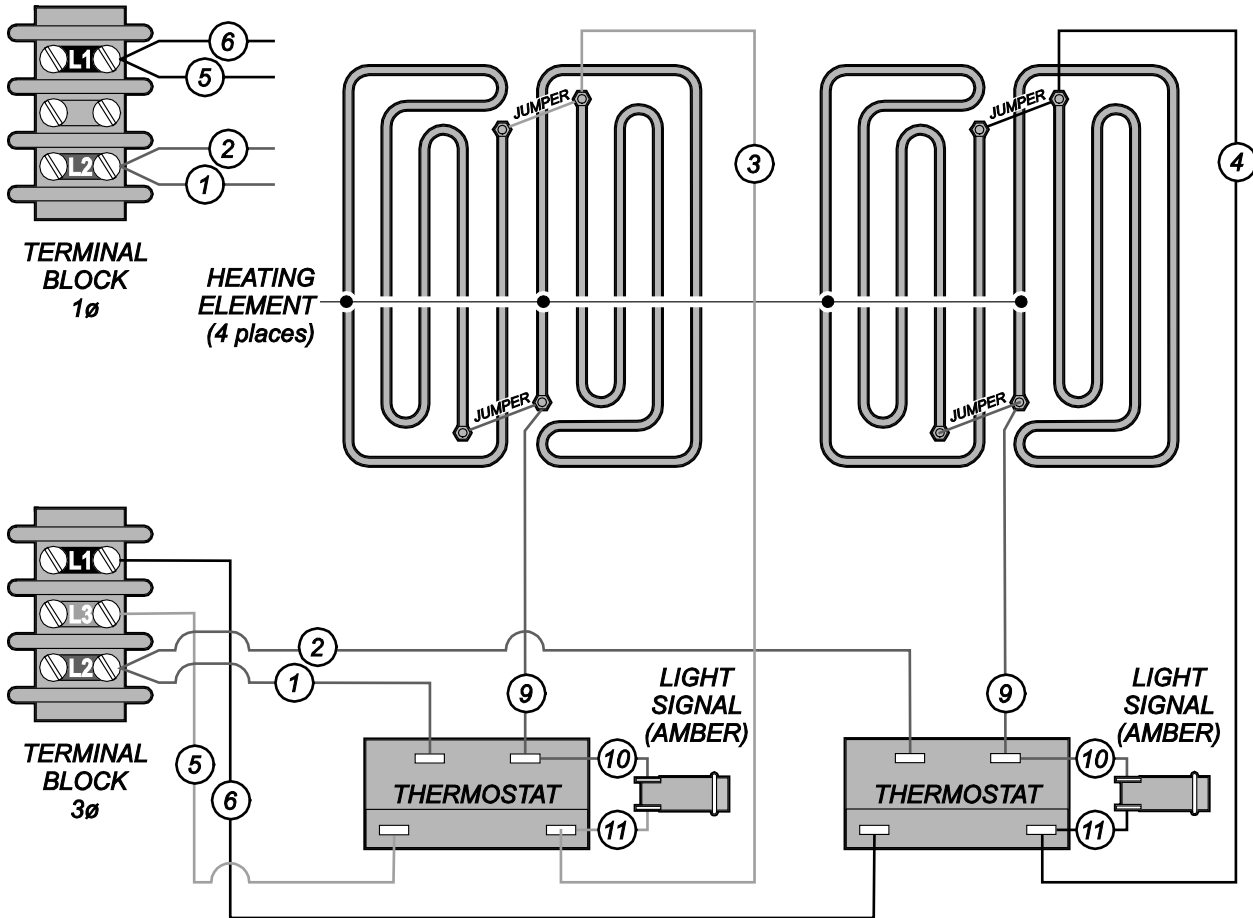

**G-19 and G-196**  
**208V 240V 480V**

p/n 31274 issue E

VOLTS	KW	NOMINAL AMPS PER LINE			
		AMPS 3 $\phi$			AMPS 1 $\phi$
		L1	L2	L3	
208	12.0	28.8	49.9	28.8	57.6
240	12.0	25.0	43.3	25.0	50.0
480	12.0	12.5	21.6	12.5	25.0

# WIRING DIAGRAM

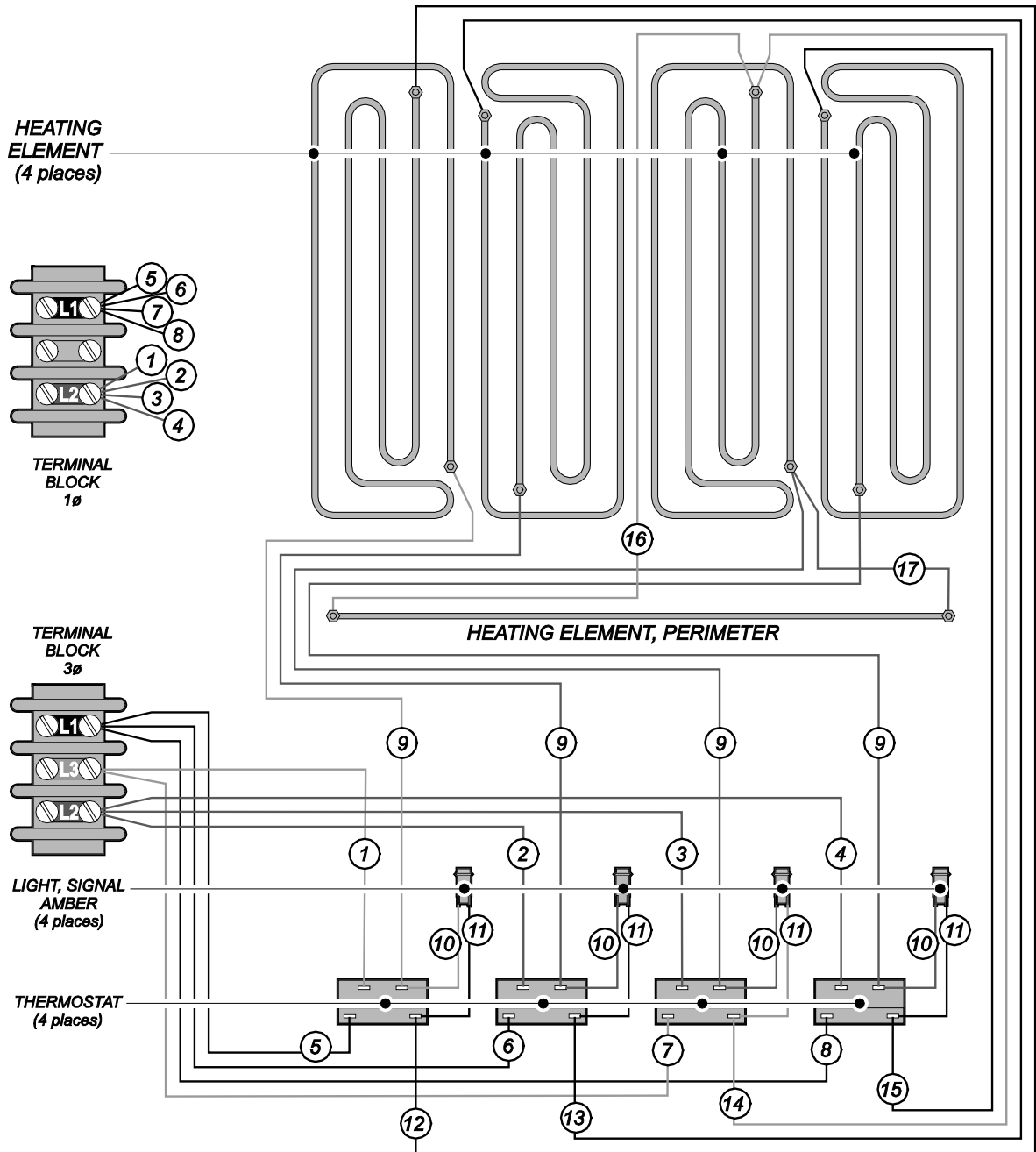

## G-23 and G-236 208V 240V 480V

VOLTS	KW	NORMAL AMPS PER LINE			
		AMPS 3PH			AMPS 1PH
		L1	L2	L3	
208	16	48.3	51.3	35.0	76.9
240		41.7	44.4	30.4	66.6
480		20.9	22.2	15.5	33.3

p/n 2M-31275 Rev. C

# WIRING DIAGRAM

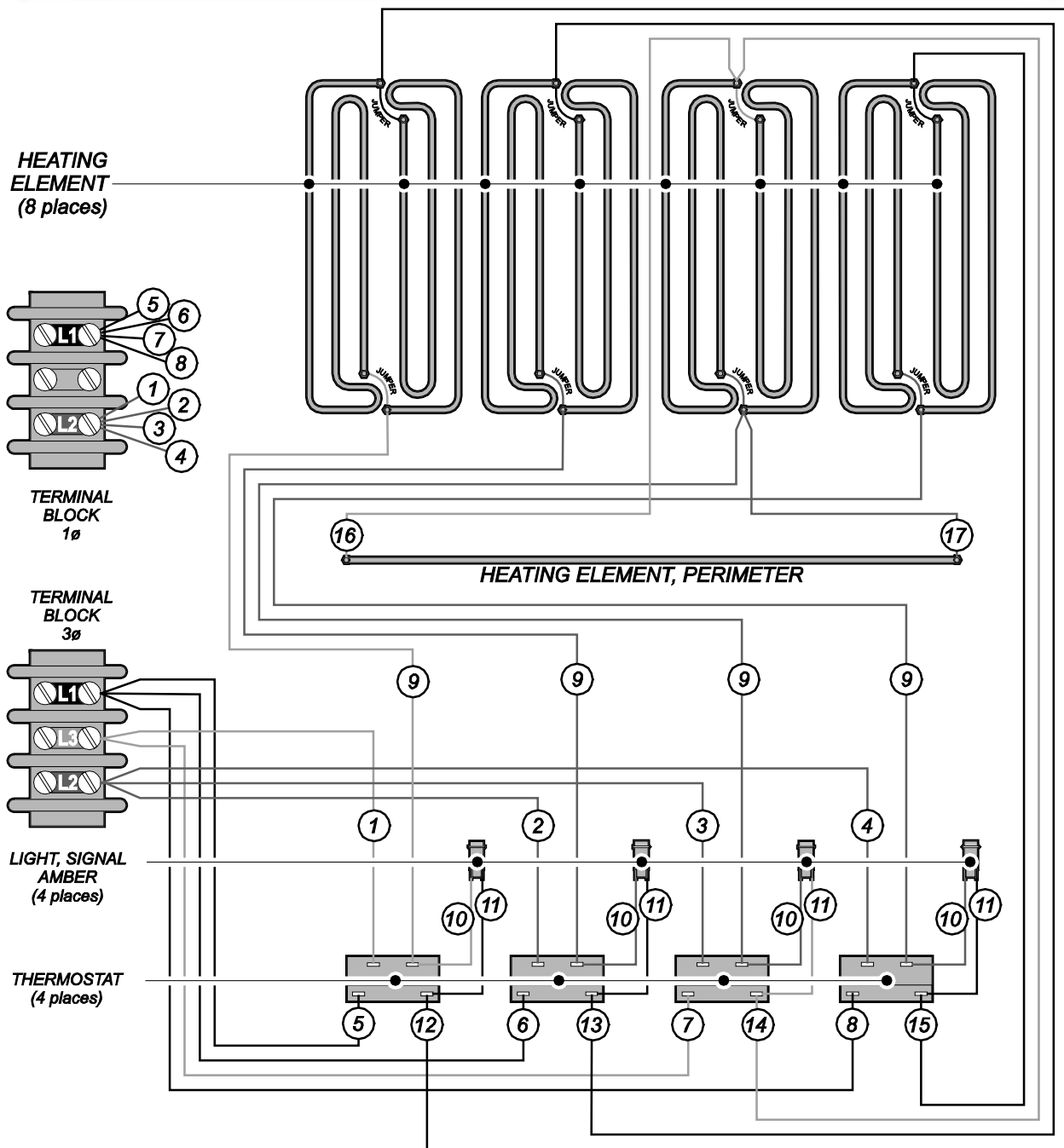

**G-24 and G-246**  
**208V 240V 480V**

p/n 48930 issue A

VOLTS	KW	NOMINAL AMPS PER LINE			
		AMPS 3Ø			AMPS 1Ø
		L1	L2	L3	
208	21.5	63.4	67.1	45.8	103.3
240	21.5	55.0	58.3	39.6	89.5
480	21.5	27.1	28.9	19.9	43.8

# WIRING DIAGRAM

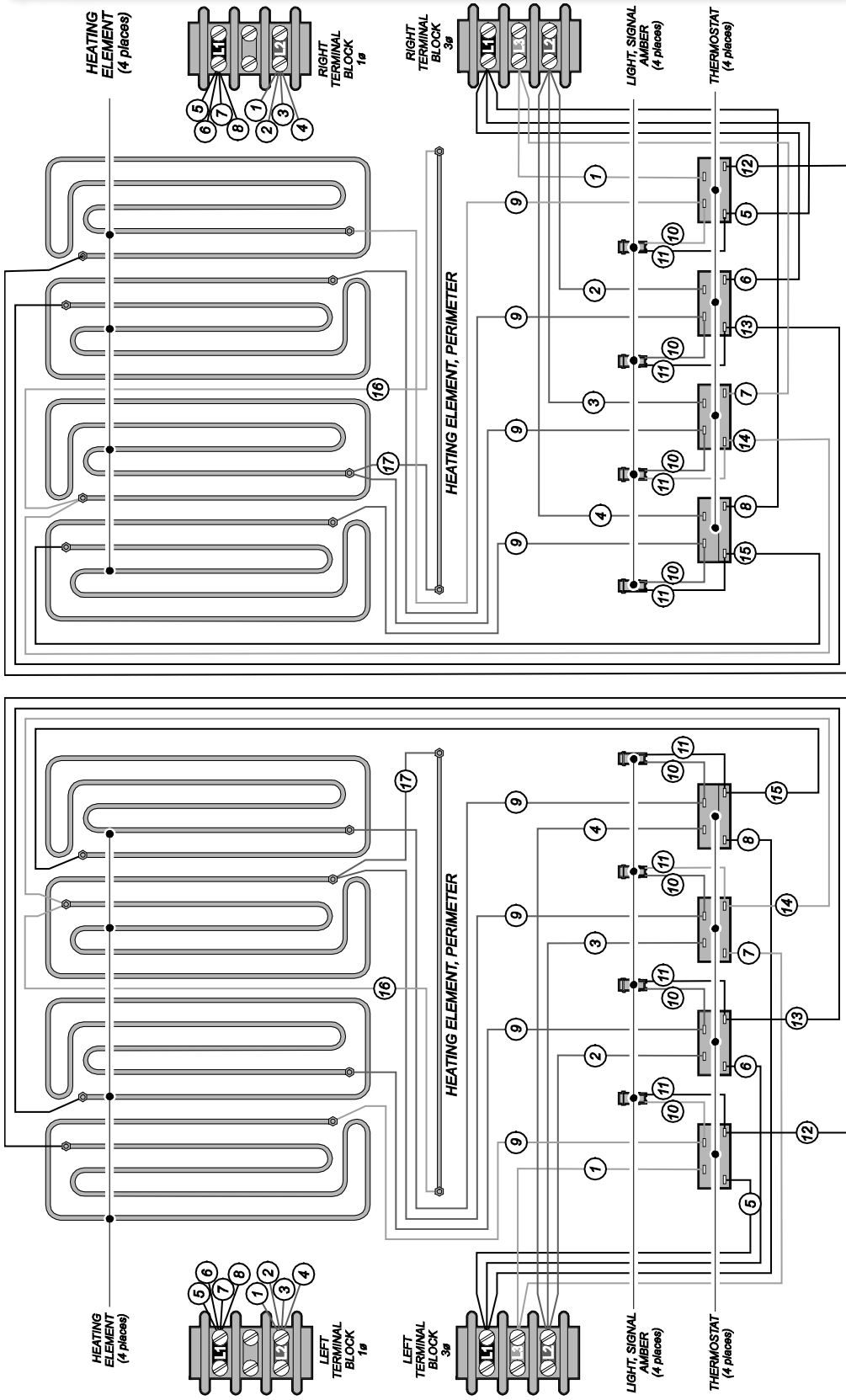

VOLTS	KW	NOMINAL AMPS PER LINE		
		AMPS 3ø	AMPS 1ø	
		L1	L2	L3
208	16.0	48.3	51.3	35.0
240	16.0	41.7	30.4	30.4
480	16.0	20.9	22.2	15.5

**RIGHT SIDE**

VOLTS	KW	NOMINAL AMPS PER LINE		
		AMPS 3ø	AMPS 1ø	
		L1	L2	L3
208	16.0	48.3	51.3	35.0
240	16.0	41.7	30.4	30.4
480	16.0	20.9	22.2	15.5

**LEFT SIDE**

**G-60 and G-606  
208V 240V 480V**

p/n 32064 Issue D

## NOTES

## PARTS & SERVICE

### DESCRIPTION

### PART NO.

LEGS, 4" , METAL SET OF 4

2A-Z0314

SPLASHGUARD, FITS G-13

DD-20632

SPLASHGUARD, FITS G-19

5G-20634

SPLASHGUARD, FITS G-23

WS-20635

SPLASHGUARD, FITS G-24

WS-20636

SPLASHGUARD, FITS G-60

WS-20637

SCRAPER, GROOVED GRIDDLE

WS-20651

**IMPORTANT:** Use only factory authorized service parts and replacement filters.

For factory authorized service, or to order factory authorized replacement parts, contact your Wells authorized service agency, or call:

### Wells Manufacturing

10 Sunnen Dr.  
St. Louis MO 63143 USA

### Service Dept.

phone: (314) 678-6314  
fax: (314) 781-2714

Service Parts Department can supply you with the name and telephone number of the WELLS AUTHORIZED SERVICE AGENCY nearest you.

## CUSTOMER SERVICE DATA

please have this information available if calling for service

RESTAURANT \_\_\_\_\_ LOCATION \_\_\_\_\_

INSTALLATION DATE \_\_\_\_\_ TECHNICIAN \_\_\_\_\_

SERVICE COMPANY \_\_\_\_\_

ADDRESS \_\_\_\_\_ STATE \_\_\_\_\_ ZIP \_\_\_\_\_

TELEPHONE NUMBER (\_\_\_\_) \_\_\_\_ - \_\_\_\_\_

EQUIPMENT MODEL NO. \_\_\_\_\_

EQUIPMENT SERIAL NO. \_\_\_\_\_

VOLTAGE / PHASE:  120  208  240  1Ø  3Ø



Wells Bloomfield proudly supports CFESA  
Commercial Food Equipment Service Association

**SERVICE TRAINING - QUALITY SERVICE**



**CUSTOMER SATISFACTION**



**WELLS MANUFACTURING**

10 Sunnen Dr., St. Louis, MO 63143

telephone: 314-678-6314

fax: 314-781-2714

[www.wellsbloomfield.com](http://www.wellsbloomfield.com)