

WELLS BLOOMFIELD, LLC
2 ERIK CIRCLE, P. O. Box 280 Verdi, NV 89439
telephone: 775-689-5703
fax: 775-689-5976
www.wellsbloomfield.com

043

OPERATION MANUAL

MODEL HDW-Series HUMIDIFIED DRAWER WARMERS

Includes
INSTALLATION
USE & CARE



Model HDW-2

IMPORTANT: DO NOT DISCARD THIS MANUAL

This manual is considered to be part of the appliance and is to be given to the OWNER or MANAGER of the restaurant, or to the person responsible for TRAINING OPERATORS of this appliance. Additional manuals are available from your WELLS DEALER.

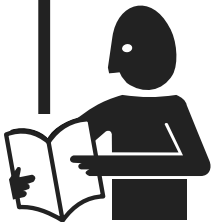

THIS MANUAL MUST BE READ AND UNDERSTOOD BY ALL PERSONS USING OR INSTALLING THIS APPLIANCE. Contact your WELLS DEALER if you have any questions concerning installation, operation or maintenance of this equipment.

PRINTED IN UNITED STATES OF AMERICA

LIMITED WARRANTY STATEMENT

Unless otherwise specified, all commercial cooking equipment manufactured by WELLS BLOOMFIELD, LLC is warranted against defects in materials and workmanship for a period of one year from the date of original installation or 18 months from the date of shipment from our factory, whichever comes first, and is for the benefit of the original purchaser only.

THIS WARRANTY IS THE COMPLETE AND ONLY WARRANTY, EXPRESSED OR IMPLIED IN LAW OR IN FACT, INCLUDING BUT NOT LIMITED TO, WARRANTIES OF MERCHANTABILITY OR FITNESS FOR ANY PARTICULAR PURPOSE, AND/OR FOR DIRECT, INDIRECT OR CONSEQUENTIAL DAMAGES IN CONNECTION WITH WELLS BLOOMFIELD PRODUCTS.

This warranty is void if it is determined that, upon inspection by an authorized service agency, the equipment has been modified, misused, misapplied, improperly installed, or damaged in transit or by fire, flood or act of God. It also does not apply if the serial nameplate has been removed, or if service is performed by unauthorized personnel. The prices charged by Wells Bloomfield for its products are

based upon the limitations in this warranty. Seller's obligation under this warranty is limited to the repair of defects without charge by a Wells Bloomfield factory authorized service agency or one of its sub-service agencies. This service will be provided on customer's premises for non-portable models. Portable models (a device with a cord and plug) must be taken or shipped to the closest authorized service agency, transportation charges prepaid, for service. In addition to restrictions contained in this warranty, specific limitations are shown in the Service Policy and Procedure Guide. Wells Bloomfield authorized service agencies are located in principal cities. This warranty is valid in the United States and Canada and void elsewhere. Please consult your classified telephone directory, your foodservice equipment dealer or contact:

**Service Department, Wells Bloomfield, LLC
P.O. Box 280, Verdi, Nevada 89439
phone (775) 689-5707 or fax (775) 689-5976**

for information and other details concerning warranty.

SERVICE POLICY AND PROCEDURE GUIDE and ADDITIONAL WARRANTY EXCLUSIONS

1. Resetting of safety thermostats, circuit breakers, over load protectors, and/or fuse replacements are **not** covered by this warranty unless warranted conditions are the cause.
2. All problems due to operation at **voltages or phase other than specified on equipment nameplates** are **not** covered by this warranty. Conversion to correct voltage and/or phase must be the customer's responsibility.
3. All problems due to **electrical connections not made in accordance with electrical code requirements and wiring diagrams** supplied with the equipment are **not** covered by this warranty.
4. Replacement of items **subject to normal wear**, to include such items as knobs, light bulbs; and, normal maintenance functions including adjustments of thermostats, adjustment of micro switches and replacement of fuses and indicating lights are **not** covered by warranty.
5. Damage to electrical cords and/or plug due to exposure to excessive heat are **not** covered by this warranty.
6. Full use, care, and maintenance instructions supplied with each machine. Noted maintenance and preventative maintenance items, such as servicing and cleaning schedules, are customer responsibility. Those miscellaneous adjustments noted are customer responsibility. Proper attention to preventative maintenance and scheduled maintenance procedures will prolong the life of the appliance.
7. Travel mileage is limited to **sixty (60) miles** from an Authorized Service Agency or one of its sub-service agencies.
8. All labor shall be performed during regular working hours. Overtime premium will be charged to the buyer.
9. All genuine Wells replacement parts are warranted for ninety (90) days from date of purchase on non-warranty equipment. This parts warranty is limited only to replacement of the defective part(s). **Any use of non-genuine Wells parts completely voids any warranty.**
10. Installation, labor, and job check-outs are **not** considered warranty and are thus **not** covered by this warranty.
11. Charges incurred by delays, waiting time or operating restrictions that hinder the service technician's ability to perform service are **not** covered by warranty. This includes institutional and correctional facilities.

SHIPPING DAMAGE CLAIM PROCEDURE

NOTE: For your protection, please note that equipment in this shipment was carefully inspected and packaged by skilled personnel before leaving the factory. Upon acceptance of this shipment, the transportation company assumes full responsibility for its safe delivery.

IF SHIPMENT ARRIVES DAMAGED:

1. **VISIBLE LOSS OR DAMAGE:** Be certain that any visible loss or damage is noted on the freight bill or express receipt, and that the note of loss or damage is signed by the delivery person.
2. **FILE CLAIM FOR DAMAGE IMMEDIATELY:** Regardless of the extent of the damage.

3. **CONCEALED LOSS OR DAMAGE:** if damage is unnoticed until the merchandise is unpacked, notify the transportation company or carrier immediately, and file "CONCEALED DAMAGE" claim with them. This should be done within fifteen (15) days from the date the delivery was made to you. Be sure to retain the container for inspection.

Wells Bloomfield cannot assume liability for damage or loss incurred in transit. We will, however, at your request, supply you with the necessary documents to support your claim.

TABLE OF CONTENTS

WARRANTY	xi
SPECIFICATIONS	1
FEATURES & OPERATING CONTROLS	2
PRECAUTIONS & GENERAL INFORMATION	3
AGENCY LISTING INFORMATION	3
INSTALLATION	4
OPERATION	6
Programming Instructions	7
CLEANING INSTRUCTIONS	8
PARTS & SERVICE	9
CUSTOMER SERVICE DATA	9

INTRODUCTION

Thank You for purchasing this Wells Bloomfield appliance.

Proper installation, professional operation and consistent maintenance of this appliance will ensure that it gives you the very best performance and a long, economical service life.

This manual contains the information needed to properly install this appliance, and to use and care for the appliance in a manner which will ensure its optimum performance.

SPECIFICATIONS

MODEL	VOLTS 1 ϕ	WATTS	AMPS	POWER SUPPLY CORD
HDW-1 HDW-2	120	1500	12.5	NEMA 5-15P
HDW-1 HDW-2	208	1130	5.4	NEMA 6-15P
	240	1500	6.3	
HDWN-1 HDWN-2	120	1500	12.5	NEMA 5-15P
HDWN-1 HDWN-2	208	1130	5.4	NEMA 6-15P
	240	1500	6.3	

FEATURES & OPERATING CONTROLS

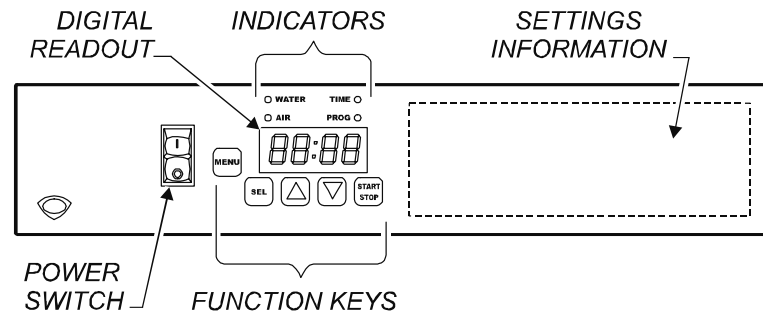

CONTROL PANEL

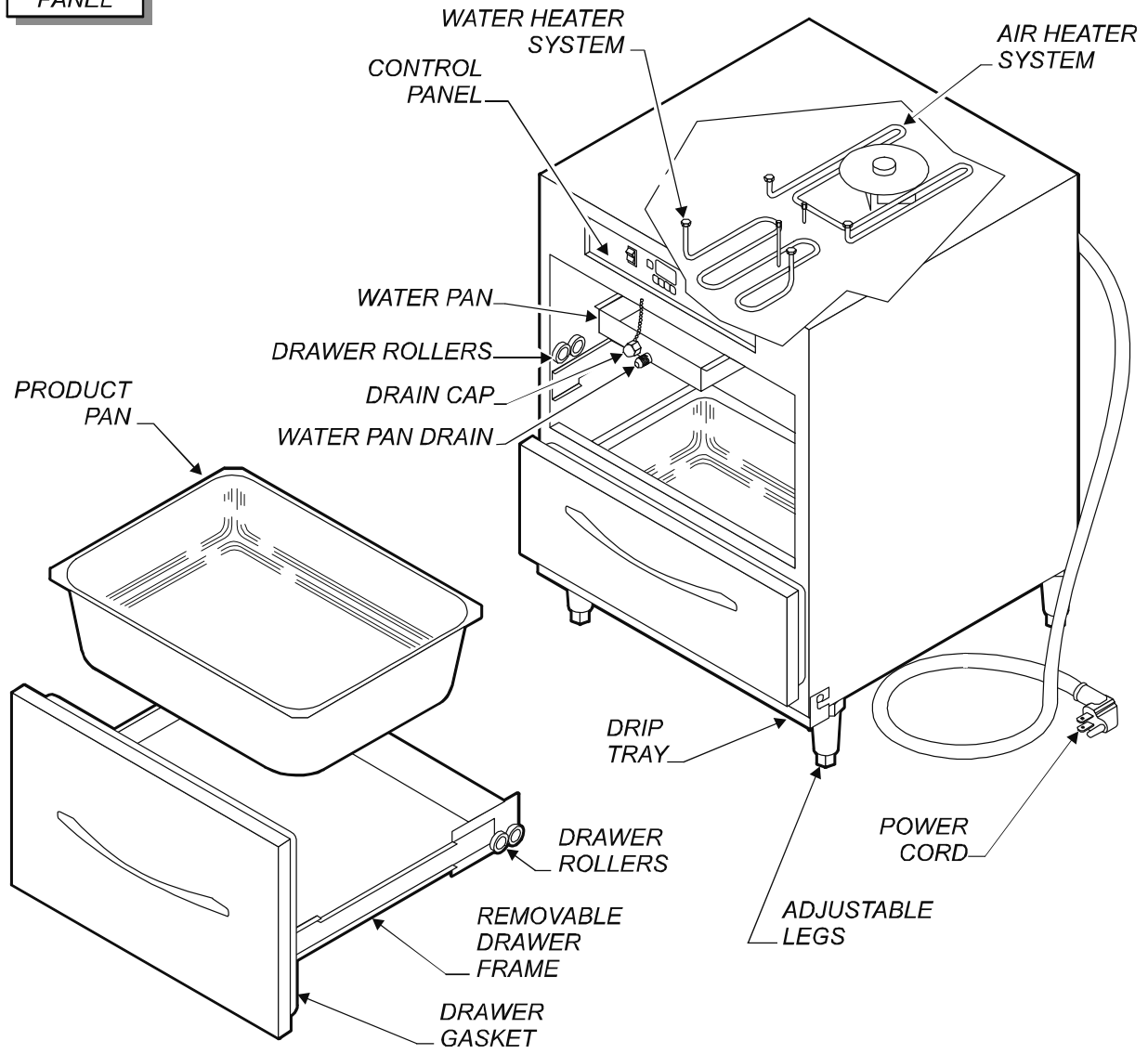

NOTE: HDW-2 DUAL-DRAWER STANDARD WIDTH UNIT SHOWN.
SINGLE-DRAWER AND NARROW WIDTH UNITS ARE SIMILAR

043 p/n 305986 OpM CT Humidified Drawer Warmer

FEATURES & OPERATING CONTROLS (continued)

This appliance is intended for use in commercial establishments only.

This appliance is intended to hold previously prepared food at serving temperature for human consumption. No other use is recommended or authorized by the manufacturer or its agents.

Operators of this appliance must be familiar with the appliance use, limitations and associated restrictions. Operating instructions must be read and understood by all persons using or installing this appliance.

Cleanliness of this appliance is essential to good sanitation. Read and follow all included cleaning instructions and schedules to ensure the safety of the food product.

Disconnect this appliance from electrical power before performing any maintenance or servicing.

This appliance is not jet stream approved. Do not direct water jet or steam jet at this appliance, or at any control panel or wiring. Do not splash or pour water on, in or over any control or wiring. Do not wash floor around this appliance with water or steam jet.

Exposed surfaces of this appliance can be hot to the touch and may cause burns.

Air and water heaters will be very hot when in use. Contact will cause severe injury.

Do not operate this appliance if the control panel is damaged. Do not operate this appliance if the keypad section of the control panel is torn or broken. Call your Authorized Wells Service Agent for service.

The technical content of this manual, including any wiring diagrams, schematics, parts breakdown illustrations and/or adjustment procedures, is intended for use by qualified technical personnel.

Any procedure which requires the use of tools must be performed by a qualified technician.

This manual is considered to be a permanent part of the appliance. This manual and all supplied instructions, diagrams, schematics, parts breakdown illustrations, notices and labels must remain with the appliance if it is sold or moved to another location.



WARNING: ELECTRIC SHOCK HAZARD

All servicing requiring access to non-insulated electrical components must be performed by a factory authorized technician. DO NOT open any access panel which requires the use of tools. Failure to follow this warning can result in severe electrical shock.



CAUTION: RISK OF DAMAGE

DO NOT connect or energize this appliance until all installation instructions are read and followed. Damage to the appliance will result if these instructions are not followed.



CAUTION: HOT SURFACE

Exposed surfaces can be hot to the touch and may cause burns.

AGENCY LISTING INFORMATION

This appliance conforms to NSF Standard 4 for sanitation only if installed in accordance with the supplied *Installation Instructions* and maintained according to the instructions in this manual.

This appliance is  Listed under UL File E6070.

This appliance is  Listed under UL File E6070.



STD 4



E6070



E6070

INSTALLATION

NOTE: DO NOT discard the carton or other packing materials until you have inspected the appliance for hidden damage and tested it for proper operation. Refer to *SHIPPING DAMAGE CLAIM PROCEDURE* on the inside front cover of this manual.



WARNING: **RISK OF** **PERSONAL INJURY**

Installation procedures must be performed by a qualified technician with full knowledge of all applicable electrical codes. Failure can result in personal injury and property damage.

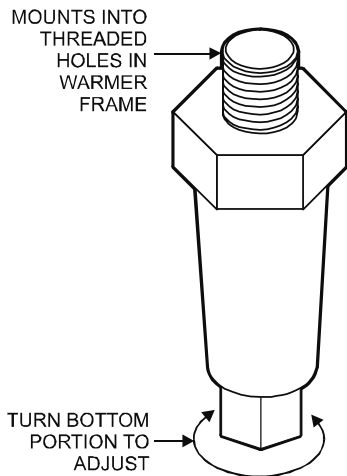

UNPACKING & INSPECTION

Carefully remove the appliance from the carton. Remove all protective plastic film, packing materials and accessories from the Appliance before connecting electrical power or otherwise performing any installation procedure.

Carefully read all instructions in this manual and the *Installation Instruction Sheet* packed with the appliance before starting any installation.

Read and understand all labels and diagrams attached to the appliance.

Carefully account for all components and accessories before discarding packing materials. Store all accessories in a convenient place for later use.

COMPONENTS

1 set	ADJUSTABLE LEGS
1 ea.	WATER PAN
1 ea.	DRIP TRAY
1 or 2 ea.	REMOVABLE DRAWER FRAME(S)
1 or 2 ea.	PRODUCT PAN(S)

SETUP

Setup the appliance only on a firm, level, non-combustible surface. Verify local codes for requirements. Concrete, tile, terrazzo or metal surfaces are recommended. Metal over combustible material may not meet code for non-combustible surfaces.

Verify that the unit sits firmly **ON ALL FOUR LEGS**. With a spirit level, check that the appliance is level front-to-back and side-to-side. With the adjustable legs, adjust as required to level the appliance. All four legs must be adjusted to firmly contact the floor in order to prevent tipping.

Refer to the *Installation Instruction Sheet* for required clearances. Maintain required clearances between the appliance and adjacent combustible surfaces.

Install removable drawer frame(s) and product pan(s) as required.

Install drip tray on hooks under bottom drawer.

Avoid storing flammable or combustible materials in, on or near the appliance.

ELECTRICAL

Refer to electrical specifications on page 1. Circuit must meet or exceed the amperage and wattage requirements listed.

120 Volt units require a properly grounded NEMA 5-15R receptacle:

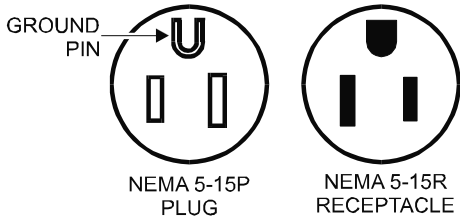

208/240 Volt units require a properly grounded NEMA 6-15R receptacle:

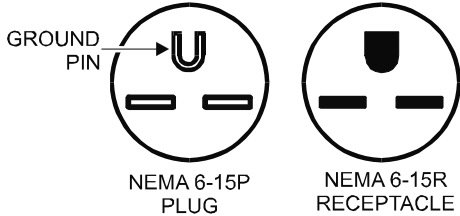

**WARNING:
ELECTRIC
SHOCK HAZARD**

All servicing requiring access to non-insulated electrical components must be performed by a factory authorized technician. DO NOT open any access panel which requires the use of tools. Failure to follow this warning can result in severe electrical shock.



**CAUTION:
RISK OF
DAMAGE**

DO NOT connect or energize this appliance until all installation instructions are read and followed. Damage to the appliance will result if these instructions are not followed.



**CAUTION:
ELECTRICAL
SHOCK HAZARD**

The ground prong of the power cord is part of a system designed to protect you from electric shock in the event of internal damage. DO NOT cut off the large round ground prong, or twist a blade to fit an existing receptacle.

IMPORTANT:

Contact a licensed electrician to install and connect electrical power to the appliance.

IMPORTANT:

Damage due to being connected to the wrong voltage or phase is NOT covered by warranty.

OPERATION



CAUTION: HOT SURFACE

Exposed surfaces can be hot to the touch and may cause burns.



CAUTION: ELECTRICAL SHOCK HAZARD

DO NOT splash or pour water onto control panel or wiring.

IMPORTANT: The water pan must be installed with care in order to prevent damage to water heating element.

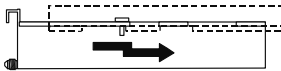
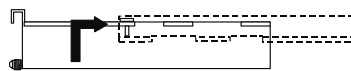
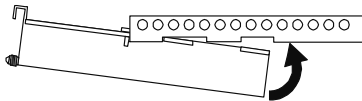

Install Water Pan

IMPORTANT:

If using distilled water or very soft water, add a tiny amount (1/100 teaspoon) of table salt to the water in the pan. The water level sensor actually senses minerals in the water, and does not detect "pure" water.

INSTALL WATER PAN

IMPORTANT: The water pan must be installed with care in order to prevent damage to water heating element.

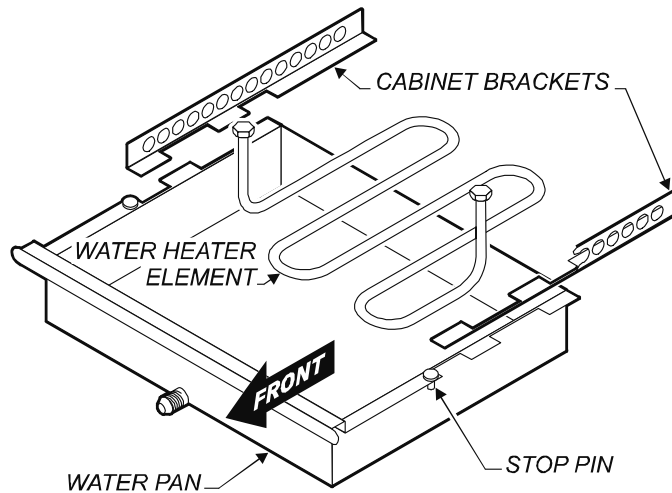

1. Raise the water pan into position. Be careful not to contact heating element:
 - a. Position drain to the front
 - b. Hold water pan so that rear is slightly lower
 - c. Stop pins of water pan touching front of cabinet brackets
2. Rotate rear of water pan up until ears clear the slots in cabinet bracket.
3. Lift front of water pan until stop pin clears front of cabinet bracket.
4. Slide water pan to rear. Stop pin will drop into cabinet bracket slot.
5. Slide pan fully to rear. Verify that water pan is secure and will not tip. Slide water pan to front until it stops.
6. Screw cap onto water pan drain. Fill water pan to within 1/2" of top. If using distilled water or very soft water, add a tiny amount of table salt to the water in the pan. Reinstall drawer frame and product pan. Close drawer.

REMOVE WATER PAN

1. Remove drawer. Place a suitable container under drain, remove drain cap and drain water pan. Discard drain water.
2. Slide water pan forward until it stops. Lift water pan until stop pins clear slots in cabinet brackets.
3. Slide water pan forward until ears clear slots in cabinet brackets.
4. Lower water pan straight down, being careful to not contact heating element.

OPERATION (continued)

NORMAL OPERATION

Plug unit into an appropriate electrical receptacle.

Add water to water pan. Proper water level is 1/2" from top.

OPERATIONAL TIPS:

Refill water pan as required during operation.

Use filtered or treated water to minimize mineral/scale build-up.

Keep drawer(s) closed to minimize water usage.

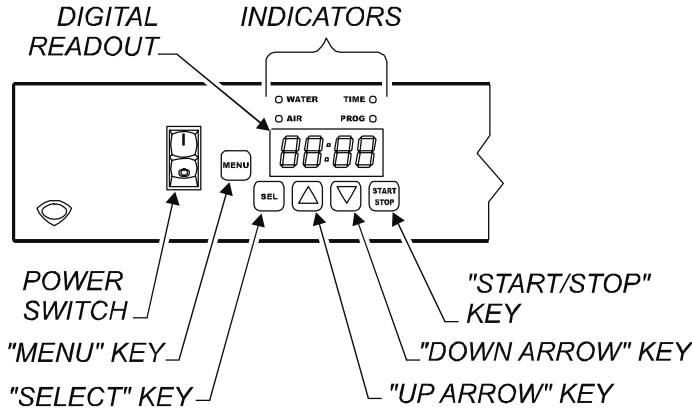

Press power switch to ON. Allow unit to pre-heat for 20 minutes.

Press the MENU key to display parameters (AIR temperature, WATER temperature or TIME setting) for the current menu.

Select parameter (AIR temperature, WATER temperature or TIME) to be displayed by pressing SEL key. The corresponding indicator will glow. Display will default to AIR temperature if no key is pressed for 5 seconds.

Change menu by pressing the MENU key at the same time as the UP ARROW or DOWN ARROW key. Any one of a maximum of eight menus may be displayed.

NOTE: Settings for AIR temperature, WATER temperature and TIME may only be changed in the program mode. Normal setting information is shown on the control panel chart.



CAUTION:
HOT SURFACE

Exposed surfaces can be hot to the touch and may cause burns.



CAUTION:
ELECTRICAL SHOCK HAZARD

DO NOT splash or pour water onto control panel or wiring.

The controller incorporates a single TIME setting. Press MENU key, then START/STOP key to start timer. An audible alarm will sound at the end of the time period. Time is factory set at 2hr. Time setting can be changed in program mode. Timer can be set from 0:00 to a maximum of 6:00.

TEMPERATURE AND HUMIDITY SETTINGS								
HIGH HEAT			MEDIUM HEAT			LOW HEAT		
AIR °F (°C)	WATER °F (°C)	MOISTURE	AIR °F (°C)	WATER °F (°C)	MOISTURE	AIR °F (°C)	WATER °F (°C)	MOISTURE
190 (88)	190 (88)	HIGH	160 (71)	160 (71)	HIGH	140 (60)	140 (60)	HIGH
190 (88)	160 (71)	MEDIUM	160 (71)	145 (63)	MEDIUM	140 (60)	135 (57)	MEDIUM
190 (88)	130 (54)	LOW	160 (71)	130 (54)	LOW	140 (60)	130 (54)	LOW

OPERATION (continued)

EXAMPLE:

Set Menu #3

AIR temp = 150°F

WATER temp = OFF

TIME setting = 2hr 30min

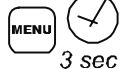
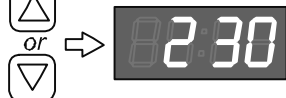
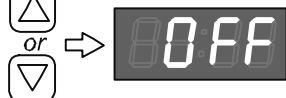
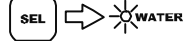
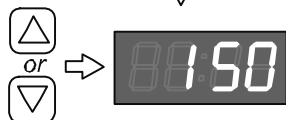
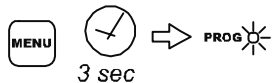
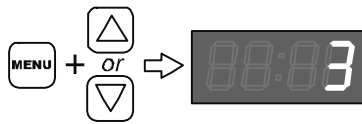

PROGRAM MODE

"MENU" KEY

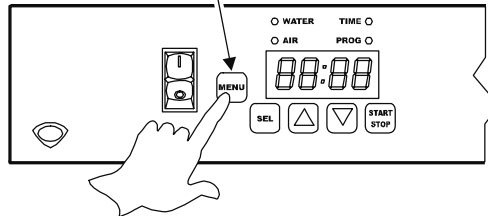

Press and hold MENU key, then UP ARROW key or DOWN ARROW key to select menu number. Release keys.

Press and hold MENU key for 3 seconds to enter programming mode. PROGRAM indicator will flash.

Press SEL key to select parameter (AIR, WATER or TIME) to be changed.

Press UP ARROW key or DOWN ARROW key to change setting.
NOTE: WATER heater may be turned off by pressing DOWN ARROW key until display reads "OFF".

Press and hold MENU key, then UP ARROW key or DOWN ARROW key to select another menu. Release keys. Press UP ARROW key or DOWN ARROW key to change setting.

Press MENU key for 3 seconds to exit.

NOTE: Control will automatically exit program mode if no key is pressed for 30 seconds.

CHANGE FROM °F to °C

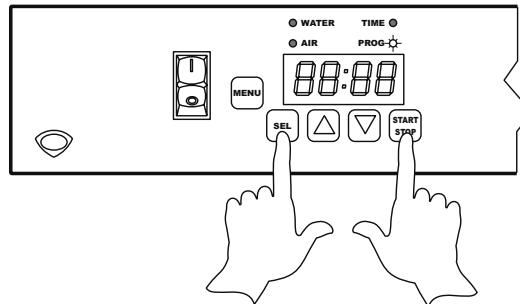

Unit is factory set to read temperature in degrees fahrenheit. To change to celcius:

Press and hold SEL and START/STOP until PROG light glows.

Press SEL 3 times. Display will read "4 F".

IMPORTANT: DO NOT change settings for "1...", "2..." or "3..."

Press UP ARROW once to change display to "4 C".

Press and hold SEL and START/STOP until PROG light goes out. Display will now read temperature in degrees celcius.

RECOMMENDED TEMPERATURE SETTINGS AND HOLDING TIMES			
TYPE OF FOOD	TIME (HRS)	TEMPERATURE °F	
		AIR	WATER
BREAD PRODUCTS	2 1/2	155	145
DAIRY & EGG PRODUCTS	2	160	155
MEATS & POULTRY ROASTED	3	170	150
MEATS & POULTRY FRIED	2	185	135
SEAFOODS WITH SAUCE	2 1/2	160	155
SEAFOODS FRIED	1 1/2	185	135
STARCHES BEANS PASTA RICE	1 1/2	150	145
VEGETABLES	2	160	155
CRISP TEXTURED FOODS	1	195	130

NOTE: Times and temperatures are approximate, and can vary for your specific application depending on product preparation, cooking time and internal food temperature.

CLEANING INSTRUCTIONS



CAUTION: ELECTRIC SHOCK HAZARD

Disconnect appliance from electric power before cleaning.



CAUTION: HOT SURFACE

Exposed surfaces can be hot to the touch and may cause burns. Allow appliance to cool before cleaning.

IMPORTANT: DO NOT spill or pour water into controls, control panel or wiring.

DO NOT submerge drawer frames in water. Water damage is **not** covered by warranty.

IMPORTANT: DO NOT use steel wool or abrasive cleansers to clean the warmer, drawers or drawer rollers.

PRECAUTIONS: Disconnect appliance from electric power. Allow unit to cool before proceeding.

FREQUENCY: Minimum -Daily

TOOLS: Mild Detergent
Clean cloth or sponge

1. Disconnect warmer from electric power. Allow to cool before cleaning.
2. Remove product pans from drawers. Remove drawers from warmer.
3. Place a suitable container under drain, remove drain cap and drain water pan. Discard drain water. Remove water pan (see page 6) and drip tray.
4. Clean drawers, product pans, water pan and drip tray by wiping with a soft cloth dampened with water and mild detergent. Rinse all components thoroughly with a soft cloth dampened with clear water. Dry all components prior to reinstalling them in warmer.
5. Sweep crumbs and other debris from warmer cavity.
6. Clean the outside of the unit by wiping with a clean cloth or sponge dampened with warm water and mild detergent. Dry with a clean cloth, then wipe with a polish formulated for stainless steel.
7. It is important to keep the slide rails clear and free from debris. Periodic cleaning of the slide rails and other adjoining parts is necessary to assure smooth drawer operation.
8. Check drawer rollers. Be sure they roll freely are free from debris.
9. Reinstall water pan (see page 6) drip tray, drawers and product pans. Reinstall drain cap on water pan and add water to water pan to 1/2" from top.

Procedure is complete

PARTS & SERVICE

ACCESSORY

PART NO.

PRODUCT PAN, all HDW-Series Warmer

22228

IMPORTANT: Use only factory authorized service parts and replacement filters.

For factory authorized service, or to order factory authorized replacement parts, contact your Wells authorized service agency, or call:

Wells Bloomfield, LLC

2 Erik Circle
P. O. Box 280
Verdi, NV 89439

Service Parts Dept.
phone: (775) 689-5707
fax: (775) 689-5976

Service Parts Department can supply you with the name and telephone number of the **WELLS AUTHORIZED SERVICE AGENCY** nearest you.

CUSTOMER SERVICE DATA

please have this information available if calling for service

RESTAURANT _____ LOCATION _____

INSTALLATION DATE _____ TECHNICIAN _____

SERVICE COMPANY _____

ADDRESS _____ STATE _____ ZIP _____

TELEPHONE NUMBER (____) _____ - _____

EQUIPMENT MODEL NO. _____

EQUIPMENT SERIAL NO. _____

VOLTAGE: (check one) 120 208 240



Wells Bloomfield proudly supports CFESA
Commercial Food Equipment Service Association

SERVICE TRAINING - QUALITY SERVICE



CUSTOMER SATISFACTION



WELLS BLOOMFIELD, LLC
2 ERIK CIRCLE, P. O. Box 280 Verdi, NV 89439
telephone: 775-689-5703
fax: 775-689-5976
www.wellsbloomfield.com

PRINTED IN UNITED STATES OF AMERICA