

WELLS BLOOMFIELD, LLC
10 Sunnen Dr., St. Louis, MO 63143
telephone: 800-807-8054
fax: 314-781-2714
www.wells-mfg.com

024



**OPERATION
MANUAL
for
BUILT-IN
Pasta
Rethermalizer**

**MODEL
HSW6DAF**

**Includes
INSTALLATION
USE & CARE**



Model HSW6DAF

IMPORTANT: DO NOT DISCARD THIS MANUAL

This manual is considered to be part of the appliance and is to be given to the OWNER or MANAGER of the restaurant, or to the person responsible for TRAINING OPERATORS of this appliance. Additional manuals are available from your WELLS DEALER.

THIS MANUAL MUST BE READ AND UNDERSTOOD BY ALL PERSONS USING OR INSTALLING THIS APPLIANCE. Contact your WELLS DEALER if you have any questions concerning installation, operation or maintenance of this equipment.

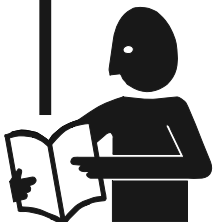

PRINTED IN UNITED STATES OF AMERICA

LIMITED WARRANTY STATEMENT

Unless otherwise specified, all commercial cooking equipment manufactured by WELLS BLOOMFIELD, LLC is warranted against defects in materials and workmanship for a period of one year from the date of original installation or 18 months from the date of shipment from our factory, whichever comes first, and is for the benefit of the original purchaser only.

THIS WARRANTY IS THE COMPLETE AND ONLY WARRANTY, EXPRESSED OR IMPLIED IN LAW OR IN FACT, INCLUDING BUT NOT LIMITED TO, WARRANTIES OF MERCHANTABILITY OR FITNESS FOR ANY PARTICULAR PURPOSE, AND/OR FOR DIRECT, INDIRECT OR CONSEQUENTIAL DAMAGES IN CONNECTION WITH WELLS BLOOMFIELD PRODUCTS. This warranty is void if it is determined that, upon inspection by an authorized service agency, the equipment has been modified, misused, misapplied, improperly installed, or damaged in transit or by fire, flood or act of God. It also does not apply if the serial nameplate has been removed, or if service is performed by unauthorized personnel. The prices charged by Wells Bloomfield for its products are

based upon the limitations in this warranty. Seller's obligation under this warranty is limited to the repair of defects without charge by a Wells Bloomfield factory authorized service agency or one of its sub-service agencies. This service will be provided on customer's premises for non-portable models. Portable models (a device with a cord and plug) must be taken or shipped to the closest authorized service agency, transportation charges prepaid, for service. In addition to restrictions contained in this warranty, specific limitations are shown in the Service Policy and Procedure Guide. Wells Bloomfield authorized service agencies are located in principal cities. This warranty is valid in the United States and Canada and void elsewhere. Please consult your classified telephone directory, your foodservice equipment dealer or contact:

Wells Bloomfield, LLC
10 Sunnen Dr., P.O.Box 430129 St. Louis MO 63143 USA
phone (314) 781-2777 or fax (314) 781-2714

for information and other details concerning warranty.

SERVICE POLICY AND PROCEDURE GUIDE and ADDITIONAL WARRANTY EXCLUSIONS

1. Resetting of safety thermostats, circuit breakers, over load protectors, and/or fuse replacements are **not** covered by this warranty unless warranted conditions are the cause.
2. All problems due to operation at **voltages or phase other than specified on equipment nameplates** are **not** covered by this warranty. Conversion to correct voltage and/or phase must be the customer's responsibility.
3. All problems due to **electrical connections not made in accordance with electrical code requirements and wiring diagrams** supplied with the equipment are **not** covered by this warranty.
4. Replacement of items **subject to normal wear**, to include such items as knobs, light bulbs; and, normal maintenance functions including adjustments of thermostats, adjustment of micro switches and replacement of fuses and indicating lights are **not** covered by warranty.
5. Damage to electrical cords and/or plug due to exposure to excessive heat are **not** covered by this warranty.
6. Full use, care, and maintenance instructions supplied with each machine. Noted maintenance and preventative maintenance items, such as servicing and cleaning schedules, are customer responsibility. Thos miscellaneous adjustments noted are customer responsibility. Proper attention to preventative maintenance and scheduled maintenance procedures will prolong the life of the appliance.
7. Travel mileage is limited to **fifty (50) miles** from an Authorized Service Agency or one of its sub-service agencies.
8. All labor shall be performed during regular working hours. Overtime premium will be charged to the buyer.
9. All genuine Wells replacement parts are warranted for ninety (90) days from date of purchase on non-warranty equipment. This parts warranty is limited only to replacement of the defective part(s). **Any** use of **non-genuine** Wells parts completely **voids any warranty**.
10. Installation, labor, and job check-outs are **not** considered warranty and are thus **not** covered by this warranty.
11. Charges incurred by delays, waiting time or operating restrictions that hinder the service technician's ability to perform service are **not** covered by warranty. This includes institutional and correctional facilities.

SHIPPING DAMAGE CLAIM PROCEDURE

NOTE: For your protection, please note that equipment in this shipment was carefully inspected and packaged by skilled personnel before leaving the factory. Upon acceptance of this shipment, the transportation company assumes full responsibility for its safe delivery.

IF SHIPMENT ARRIVES DAMAGED:

1. **VISIBLE LOSS OR DAMAGE:** Be certain that any visible loss or damage is noted on the freight bill or express receipt, and that the note of loss or damage is signed by the delivery person.
2. **FILE CLAIM FOR DAMAGE IMMEDIATELY:** Regardless of the extent of the damage.
3. **CONCEALED LOSS OR DAMAGE:** if damage is unnoticed until the merchandise is unpacked, notify the transportation company or carrier immediately, and file "CONCEALED DAMAGE" claim with them. This should be done within fifteen (15) days from the date the delivery was made to you. Be sure to retain the container for inspection.

TABLE OF CONTENTS

WARRANTY	xi
SPECIFICATIONS	1
FEATURES & OPERATING CONTROLS	2
PRECAUTIONS & GENERAL INFORMATION	3
INSTALLATION	4
OPERATION	6
CLEANING INSTRUCTIONS	7
TROUBLESHOOTING	9
EXPLODED VIEW & PARTS LIST	10-11
WIRING DIAGRAM	12
PARTS & SERVICE	13
CUSTOMER SERVICE DATA	13

INTRODUCTION

Thank You for purchasing this Wells Manufacturing Co. appliance.

Proper installation, professional operation and consistent maintenance of this equipment will ensure that it gives you the very best performance and a long, economical service life.

This manual contains the information needed to properly install this equipment, and to use and care for the equipment in a manner which will ensure its optimum performance.

SPECIFICATIONS

MODEL	VOLTS 1 ϕ	WATTS	AMPS	POWER SUPPLY CORD
HSW6DAF	208	900	4.3	NONE
	240	1200	5.0	

FEATURES & OPERATING CONTROLS

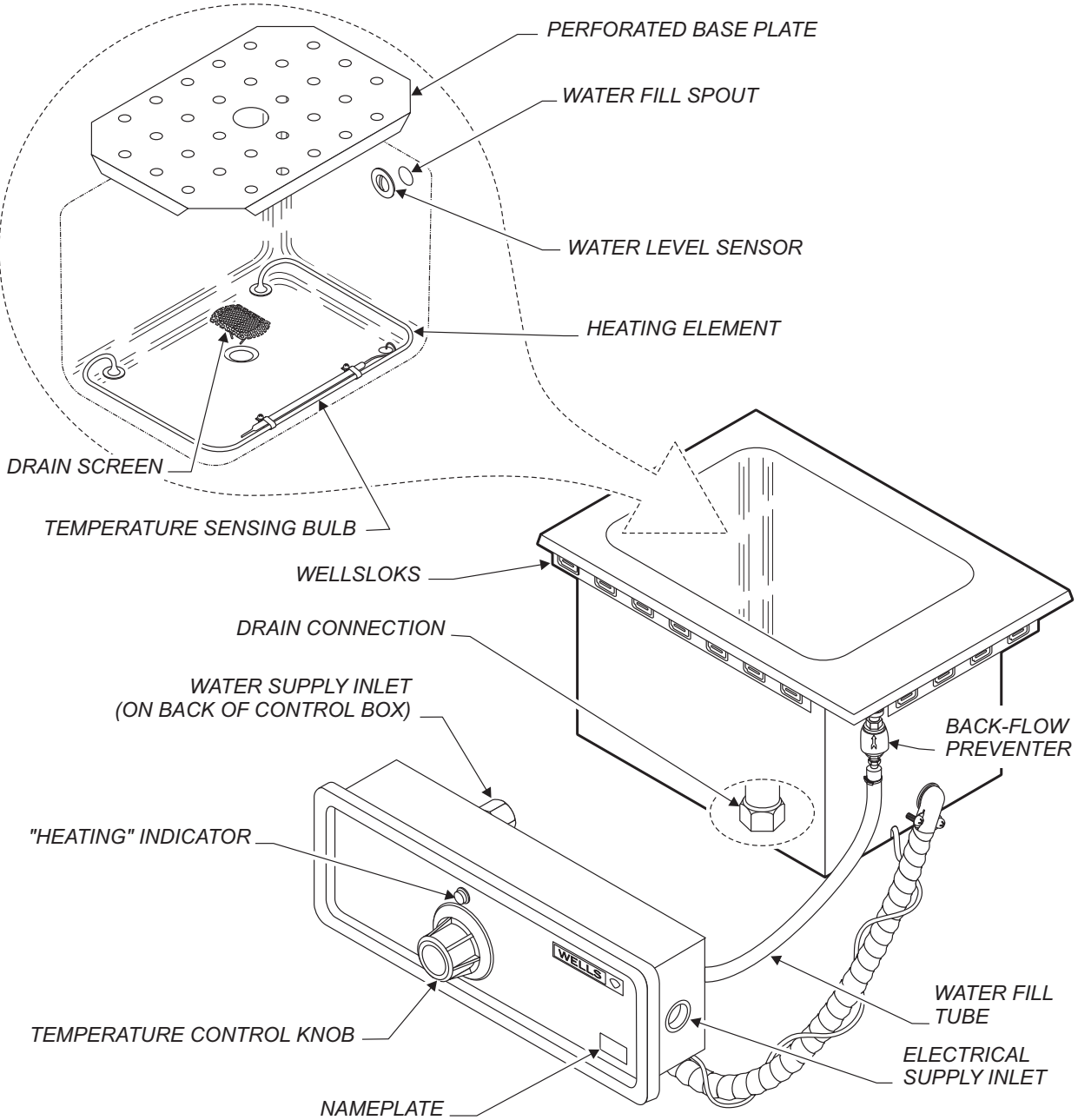

024 306391 OpManual for Rethermalizer HSW-6DAF

Fig. 1 HSW-6DAF Built-In Auto-Fill Pasta Rethermalizer - Features & Operating Controls

PRECAUTIONS AND GENERAL INFORMATION

This appliance is intended for use in commercial establishments only.

This appliance is intended to hold pre-heated food for human consumption. No other use is recommended or authorized by the manufacturer or its agents.

Operators of this appliance must be familiar with the appliance use, limitations and associated restrictions. Operating instructions must be read and understood by all persons using or installing this appliance.

Cleanliness of this appliance is essential to good sanitation. Read and follow all included cleaning instructions and schedules to ensure the safety of the food product.

Disconnect this appliance from electrical power before performing any maintenance or servicing.

This appliance is not jet stream approved. Do not direct water jet or steam jet at this appliance, or at any control panel or wiring. Do not splash or pour water on, in or over any controls, control panel or wiring.

Exposed surfaces of this appliance can be hot to the touch and may cause burns.

Do not operate this appliance if the control panel is damaged. Call your Authorized Wells Service Agent for service.

The technical content of this manual, including any wiring diagrams, schematics, parts breakdown illustrations and/or adjustment procedures, is intended for use by qualified technical personnel.

Any procedure which requires the use of tools must be performed by a qualified technician.

This manual is considered to be a permanent part of the appliance. This manual and all supplied instructions, diagrams, schematics, parts breakdown illustrations, notices and labels must remain with the appliance if it is sold or moved to another location.

This appliance is made in the USA. Unless otherwise noted, this appliance has American sizes on all hardware.



WARNING: SHOCK HAZARD

All servicing requiring access to non-insulated electrical components must be performed by a factory authorized technician. DO NOT open any access panel which requires the use of tools. Failure to follow this warning can result in severe electrical shock.



CAUTION: RISK OF DAMAGE

DO NOT connect or energize this appliance until all installation instructions are read and followed. Damage to the appliance may result if these instructions are not followed.



CAUTION: HOT SURFACE

Exposed surfaces can be hot to the touch and may cause burns.

AGENCY APPROVAL INFORMATION

This appliance is  and  listed under file E6070

This appliance conforms to NSF Standard 4 for sanitation only if installed in accordance with the supplied *Installation Instructions*.



E6070



E6070



STD 4

INSTALLATION

NOTE: DO NOT discard the carton or other packing materials until you have inspected the appliance for hidden damage and tested it for proper operation. Refer to *SHIPPING DAMAGE CLAIM PROCEDURE* on the inside front cover of this manual.

UNPACKING & INSPECTION

Carefully remove the appliance from the carton. Remove all protective plastic film, packing materials and accessories from the appliance before connecting electrical power or otherwise performing any installation procedure.

Carefully read all instructions in this manual and the *Installation Instruction Sheet* packed with the appliance before starting any installation.

Read and understand all labels and diagrams attached to the appliance.

Carefully account for all components and accessories before discarding packing materials. Store all accessories in a convenient place for later use.

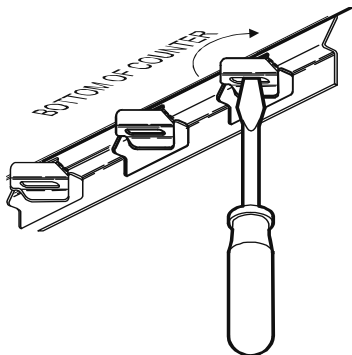

Fig. 2 Set the Wellsloks

IMPORTANT:

Water damage caused by failure to seat Wellsloks or failure to install gasket or to seal flange to counter is NOT covered by warranty

PREPARATION

Carefully read the *Installation Instruction Sheet* packed with the appliance for cutout dimensions and restrictions.

For both wood and non-combustible (i.e. metal) installation, do not install closer than 4-1/2" to front wall unless the control unit is placed beneath the warmer unit, in which case clearance to front wall may be 1". Also, do not install closer than 1" to back wall, 2" to side walls, or 6-3/4" to surface below unit.

Supplied gasket must be installed under the mounting flange, and the Wellsloks turned out to seal the appliance and control unit to the counter.

Apply a thin bead of food-grade silicone sealant where the flange meets the counter.

ELECTRICAL INSTALLATION

IMPORTANT: Appliance must be installed by a licensed electrician in accordance with all applicable codes and ordinances.

Refer to the product nameplate. Verify the electrical service power. Voltage and phase must match the nameplate specifications. Wiring the warmer to the wrong voltage can severely damage the unit or cause noticeably decreased performance.

Available electrical service amperage must meet or exceed those specifications listed on the specification sheet provided with the appliance.

The ground lug of the control unit must be connected to a suitable building ground. Ground connection will be marked "GND" or "  " .

NOTE: Wire gauge, insulation type and temperature rating , as well as type, size and construction of conduit, must meet or exceed applicable specifications of local codes and of the National Electrical Code.



**CAUTION:
SHOCK HAZARD**

The ground lug of this appliance must be connected to a suitable building ground.

IMPORTANT:
Contact a licensed electrician to install and connect electrical power to the appliance.

IMPORTANT:
Damage due to being connected to the wrong voltage or phase is NOT covered by warranty.

IMPORTANT: Electrical installation other than as specified on the specification sheet will void the UL listing, and may void the warranty.

NOTE: Plumbing connections must be made in compliance with all Federal, State and Local Plumbing Codes and Ordinances.

PLUMBING INSTALLATION

IMPORTANT: All plumbing installations must be performed by a qualified plumber.

This appliance is equipped with a DRAIN LINE that must be connected to a suitable building drain. A drain valve (provided by plumbing installer) must be installed for each unit. Drain valve operating handle must be readily accessible by the operator.

NOTE: Some jurisdictions may require an approved air gap device in the drain. It is the responsibility of the plumbing installer to determine such requirement, to provide and properly install the required device.

This appliance is equipped with autofill to maintain water level in the warmer pan. Water supply connection is 1/4" NPT. Water supply must be connected to a COLD WATER line only. Maximum supply line water pressure is 120 p.s.i.

NOTE: This appliance incorporates an internal backflow preventer between the control unit and the warmer pan. However, Some jurisdictions may require additional back-flow prevention devices in the water supply line. It is the responsibility of the plumbing installer to determine such requirement, to provide and properly install the required device.

024 306391 OpManual for Rethermalizer HSW-6DAF

OPERATION



CAUTION: HOT SURFACE

Exposed surfaces can be hot to the touch and may cause burns.



CAUTION: SHOCK HAZARD

DO NOT splash or pour water onto control panel or wiring.

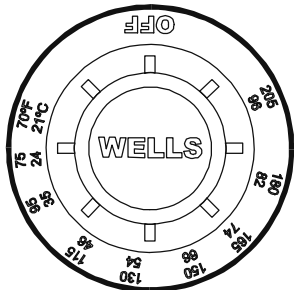

Fig. 3 Temperature Control

IMPORTANT:

Water bath rethermalizers are designed to be operated **WET ONLY**.

Heating element must be completely submerged at all times during operation

Damage caused by allowing the pan to run dry is **NOT** covered by warranty.

Never put ice into the pan. This will cause condensation on the inside of the shrouds. Damage caused by condensation is **NOT** covered by warranty.

OPERATION

Make sure the drain valve is fully closed. Install **DRAIN SCREEN** and **PERFORATED BOTTOM PLATE**. Add at least 2 quarts (1 liter) of water to pan before turning the **TEMPERATURE CONTROL KNOB** from the **OFF** position.

SUGGESTION: Add warm water, and keep the pan covered, to reduce the warm-up period.

Turn **CONTROL KNOB** to 70°F. Auto-fill will add water to the pan until the water reaches the **WATER LEVEL SENSOR**. Auto-fill will automatically maintain the proper water level.

After the pan is full, turn the **TEMPERATURE CONTROL KNOB** to the desired temperature. The **INDICATOR LIGHT** will glow. When the light goes out, water in the pan is up to temperature. Water level should be checked periodically to verify proper operation of the auto-fill feature. Running rethermalizers dry will damage the heating element.

OPERATIONAL NOTES:

DO: Always use the appropriate portion basket (provided by owner).

DO NOT place food directly into the tank.

DO NOT put ice into the pan. This will cause condensation on the inside of the shrouds. Damage caused by condensation is **NOT** covered by warranty.

DO NOT use metal implements, steel wool, or caustic or abrasive cleansers to clean rethermalizer tank.

DO: Clean heating element and water level probe daily to maintain proper rethermalizer operation.

END-OF-DAY SHUT-DOWN

Turn **TEMPERATURE CONTROL KNOB OFF**. Remove portion baskets and any utensils from warmer pan. Allow warmer to cool.

Open drain valve and allow pan to empty. Clean unit as described on page 7.

CLEANING INSTRUCTIONS

DAILY CLEANING INSTRUCTIONS

PREPARATIONS: Turn control knob to OFF. Disconnect warmer from electric power.
Allow rethermalizer to cool before proceeding.
Drain water from pan.
Remove perforated bottom plate, drain screen and any portion baskets or utensils from pan.

FREQUENCY: Minimum - daily.

TOOLS: Mild Detergent
Solution: 10 Parts Warm Water to 4 Parts Vinegar
Plastic Scouring Pad
Clean Cloth or Sponge

1. Wipe entire unit down using a clean cloth or sponge and mild detergent.
2. Use a plastic scouring pad to remove any hardened food particles or mineral deposits. Pay particular attention to removing scale and lime build-up on the heating elements and water level probes.

IMPORTANT: DO NOT use steel wool for cleaning.

IMPORTANT: Use care when cleaning around the temperature sensing probe to avoid damaging the capillary tube.

3. Rinse rethermalizer thoroughly with a vinegar and water solution to neutralize all detergent cleanser residue. Rinse with clear water.
4. Inspect rethermalizer tank for damage. Damage to the tank may allow grease and water to leak into insulation and heating element, causing a potential fire and/or electric shock hazard. Contact your Authorized Wells Service Agency to inspect rethermalizer if water or grease contamination is suspected.
5. Reinstall drain screen and perforated bottom plate.

NOTE: For heavy scale build-up, clean with a commercial delime cleaner (see page 8).

Procedure is complete



**CAUTION:
SHOCK HAZARD**

Do NOT splash or pour water into or over any control panel or wiring.



**CAUTION:
SHOCK HAZARD**

Disconnect warmer from electric power before cleaning



**CAUTION:
BURN HAZARD**

Allow warmer to cool completely before cleaning.

CLEANING INSTRUCTIONS (continued)



CAUTION: CHEMICAL BURN HAZARD

Deilimng chemicals may be caustic. Wear appropriate personal protective equipment. Follow cleaner manufacturer's instructions for safest use.

WEEKLY CLEANING INSTRUCTIONS

PREPARATIONS: Remove any insets, pans and/or adapter tops. Drain or remove water from well if used for wet operation.

FREQUENCY: Weekly, or whenever lime or scale is seen accumulating on the sides of the warmer pans.

TOOLS: Commercial Delime Cleaner
Plastic Scouring Pad
Clean Cloth or Sponge

1. Add water to pans until water is at normal operating level (1" - 1 1/2" deep) or covers accumulated scale.
2. Heat water to maximum temperature (190°F or higher).
3. Pour contents of one package of commercial delime cleaner into each warmer pan. Stir to dissolve cleaner. Turn heat control OFF. Cover pans.
4. Allow solution to soak at least one hour, or overnight for heavy scale buildup.
5. Drain hot water from pans. Scrub with a plastic scouring pad. Rinse thoroughly with hot water, then dry.
6. Refill pans with hot tap water and resume operation.
7. Heavy scale buildup may require additional treatments.

TROUBLESHOOTING SUGGESTIONS

SYMPTOM	POSSIBLE CAUSE	SUGGESTED REMEDY
No power to rethermalizer	Circuit breaker off or tripped	Reset circuit breaker
Rethermalizer will not heat	Temperature control not set	Set control to desired temperature
	Internal damage	Contact your Authorized Wells Service Agency for repairs
Autofill does not add water to rethermalizer	Water supply not turned on	Turn on water supply
	Internal damage	Contact your Authorized Wells Service Agency for repairs
Rethermalizer overflows (Autofill does not shut off water fill)	Scale build-up on upper water level probe	Clean water level probe with Wells Lime & Scale Cleaner
	Internal damage	Contact your Authorized Wells Service Agency for repairs
Rethermalizer trips circuit breaker	Tank leaking or other internal damage	Contact your Authorized Wells Service Agency for repairs
	Internal damage	Contact your Authorized Wells Service Agency for repairs
Rethermalizer slow to heat	Mineral deposits on heating element acting as an insulator	Clean tank with Wells Lime & Scale Cleaner
	Connected to wrong voltage	Verify supply voltage - must match voltage on rethermalizer nameplate

There are no user-serviceable components in this appliance.
 In all instances of damage or malfunction, contact your Authorized Wells Service Agency for repairs.

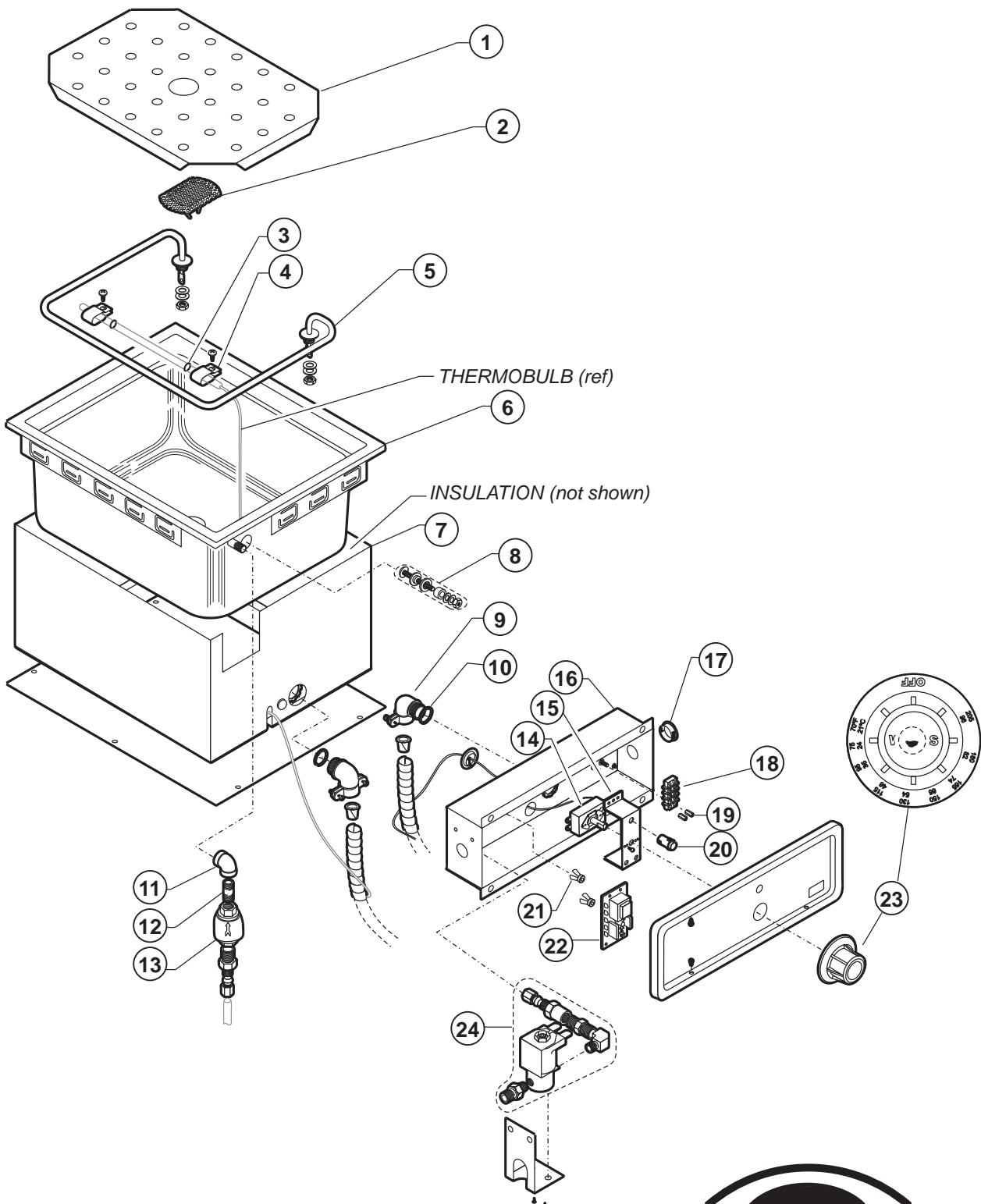

Model: HSW6DAF
PASTA RETHERMALIZER
CHILI'S
 PL024



IL1763 Rev. A 5/6/09

024 306391 OpManual for Rethermalizer HSW-6DAF

HSW6DAF PASTA RETHERMALIZER - CHILI'S			
Fig No	Part No	Qty	Description
1	P2-306385	1	PERFORATED BOT HSW6DAF
2	P2-31869	1	SCREEN DRAIN ASSY
3	2B-37946	3	RING THERMO SPACE .310
4	D8-30291	2	CLAMP BULB THERMO HD121
5	2N-306369UL	1	ELEMENT HEATING HSW6DAF
6	P2-306383	1	TOP/PAN ASSY HSW6DAF CHILI'S
7	P2-306384	1	SHELL WRAP HSW-6DAF ROHS
8	WS-503713	1	PROBE ASSY SS AUTOFILL
9	2K-34136X	2	FTG FLEX CON 90 X 1/2 MOD
10	2I-Z12311	2	GASKET-FIBER WASHER
11	2K-48198	1	ELBOW 3/8 X 90 DEG BRASS
12	2K-48197	1	NIPPLE 3/8 NPT X 2 BRASS
13	2V-47650	1	VALVE ANTISYPHON 3/8
14	2T-40509	1	THERMO CTRL HW/SMP
15	P2-40843	1	BRKT MTG THERMO INFINITE
16	P2-306960	1	BOX OUTLET MOD-100TDM AF
17	2K-31040	1	BUSHING 7/8 O.D.
18	WS-50131	1	TERM BLK KIT 3-POLE .85AMP
19	2C-41974	2	NUT 8-32 HEX 7/8 LONG ALU
20	2J-35687	1	LIGHT SIGNAL GLO DOT
21	2I-40034	4	GROMMET SCREW T4
22	2E-306865	1	CONTROL LIQ LEVEL 208/240
23	2R-40498	1	KNOB ASSY MOD 100DT
24	WS-503250	1	VALV SOL ASSY MOD100 CHILI'S
24	2V-70774	1	VALVE SOLENOID 240V ROHS

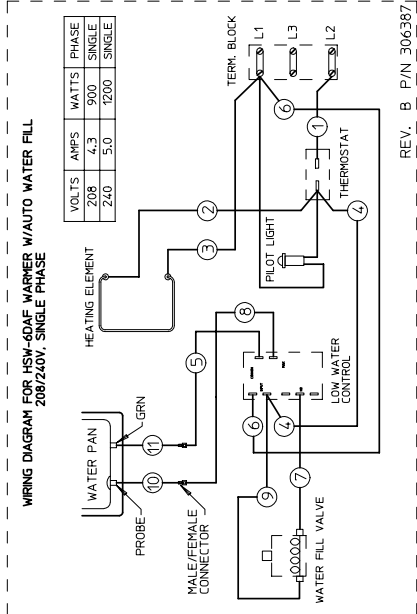

B	SEE ECN-13059	L.M	DTL	G.C	05-10-06
A	SEE ECN-12923	L.M	D.P	G.C	08-30-05
(-)	ENG. REL. ECN-12752		DTL	L.M	09-13-04
ISSUE	WAS	BY	APP	DATE	
DO NOT SCALE DWG. REVISIONS					
TOL. PART NAME					
UNLESS NOTED DIAGRAM WIRING					
DEC.	USED ON				
.0 ± .030	HSW-6DAF				
.00 ± .020	SCALE	DWN.	ENG.	CKD.	
.000 ± .005	NONE	DTL.	D.C	L.M	
ANG. ± 1°	MATERIAL 2 X 3 ON WHITE STOCK WITH #467 PERMANENT ADHESIVE BACK				



B BLOOMFIELD
 VERDI. NV.
 PART NO. *
306387

(REF. WIRE SET PN 306388)

PARTS & SERVICE

DESCRIPTION

none available at this time

PART NO.

IMPORTANT: Use only factory authorized service parts.

For factory authorized service, or to order factory authorized replacement parts, contact your Wells authorized service agency, or call:

Wells Bloomfield, LLC
10 Sunnen Drive
St. Louis, MO 63143

Service Parts Dept.
phone: (800) 807-9054
fax: (314) 781-2714

Service Parts Department can supply you with the name and telephone number of the **WELLS AUTHORIZED SERVICE AGENCY** nearest you.

CUSTOMER SERVICE DATA

please have this information available if calling for service

RESTAURANT _____ LOCATION _____
INSTALLATION DATE _____ TECHNICIAN _____
SERVICE COMPANY _____
ADDRESS _____ STATE _____ ZIP _____
TELEPHONE NUMBER (____) _____ - _____

EQUIPMENT MODEL NO. _____
EQUIPMENT SERIAL NO. _____
VOLTAGE: (check one) 208 240



Wells Bloomfield proudly supports CFESA
Commercial Food Equipment Service Association

SERVICE TRAINING - QUALITY SERVICE



CUSTOMER SATISFACTION

Created for



by

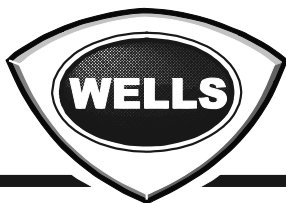

WELLS BLOOMFIELD, LLC
10 Sunnen Dr., St. Louis, MO 63143
telephone: 800-807-8054
fax: 314-781-2714
www.wells-mfg.com

PRINTED IN UNITED STATES OF AMERICA