

011C

WELLS MANUFACTURING

265 Hobson Street, Smithville, Tennessee 37166
telephone: 314-678-6314
fax: 314-781-2714
www.wells-mfg.com

OWNERS MANUAL

**BUILT-IN WELL
MODULAR
WARMERS
with
INFINITE,
THERMOSTAT or DIGITAL
CONTROLS**



MOD-200T

MODELS

M200, M227, MOD200, MOD227
M300, M327, MOD300, MOD327
M400, M427, MOD400, MOD427
M500, M527, MOD500, MOD527



MOD-200TDN

**Includes
INSTALLATION
USE & CARE
EXPLODED VIEW
PARTS LIST
WIRING DIAGRAM**

IMPORTANT: DO NOT DISCARD THIS MANUAL

This manual is considered to be part of the appliance and is to be given to the OWNER or MANAGER of the restaurant, or to the person responsible for TRAINING OPERATORS of this appliance. Additional manuals are available from your WELLS DEALER.

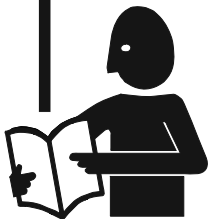

THIS MANUAL MUST BE READ AND UNDERSTOOD BY ALL PERSONS USING OR INSTALLING THIS APPLIANCE. Contact your WELLS DEALER if you have any questions concerning installation, operation or maintenance of this equipment.

LIMITED EQUIPMENT WARRANTY

Wells Manufacturing warranties new products to be free from defects in material and/or workmanship for a period of one [1] year from the date of original installation, except as noted below. Defects that occur as a result of normal use, within the time period and limitations defined in this warranty, will at Wells' discretion have the parts replaced or repaired by Wells or a Wells-authorized service agency.

THIS WARRANTY IS SUBJECT TO ALL LISTED CONDITIONS.

Repairs performed under this warranty are to be performed by a Wells-authorized service agency. Wells will not be responsible for charges incurred or service performed by non-authorized repair agencies.

In all cases, the nearest Wells-authorized service agency must be used.

Wells will be responsible for normal labor charges incurred in the repair or replacement of a warrantied product within 50 miles (80.5 km) of an authorized service agency. Time and expense charges for anything beyond that distance will be the responsibility of the owner. All labor will need to be performed during regular service hours. Any overtime premium will be charged to the owner. For all shipments outside the U.S.A. and Canada, please see the International Warranty for specific details.

It is the responsibility of the owner to inspect and report any shipping damage claims, hidden or otherwise, promptly following delivery.

No mileage or travel charges will be honored on any equipment that is deemed portable. In general, equipment with a cord and plug weighing less than 50 lb. (22.7 kg) is considered portable and should be taken or shipped to the closest authorized service agency, transportation prepaid.

CONTACT

Should you require any assistance regarding the operation or maintenance of any Wells equipment; write, phone, fax or email our service department. In all correspondence mention the model number and the serial number of your unit, as well as the voltage or type of gas you are using.

Business hours are 8:00 a.m. to 4:30 p.m. Central Standard Time

Telephone 314.678.6314

Fax 314.781.2714

Email customerservice@star-mfg.com

www.wells-mfg.com

WARRANTY EXCLUSIONS

THE FOLLOWING WILL NOT BE COVERED UNDER WARRANTY.

- Any product which has not been installed, cleaned, maintained, or used in accordance with the directions published in the appropriate installation sheet and/or owner's manual as well as national and local codes, including incorrect gas or electrical connection. Wells is not liable for any unit which has been mishandled, abused, misapplied, subjected to chlorides, harsh chemicals, or caustic cleaners, damaged from exposure to hard water, modified by unauthorized personnel, damaged by flood, fire, or other acts of nature [or God], or which have an altered or missing serial number.
- Installation, labor, and job checkouts, calibration of heat controls, air and gas burner/bypass/pilot adjustments, gas or electrical system checks, voltage and phase conversions, cleaning of equipment, or seasoning of griddle surface.
- Replacement of fuses or resetting of circuit breakers, safety controls, or reset buttons.
- Replacement of broken or damaged glass components, quartz heating elements, and light bulbs.
- Labor charges for all removable parts in gas charbroilers and hotplates, including but not limited to burners, grates, and radiants.
- Any labor charges incurred by delays, waiting time, or operating restrictions that hinder a service technician's ability to perform service.
- Parts that fail or are damaged due to normal wear or labor for replacement of items that can easily be replaced during a daily cleaning routine. such as but not limited to silicone belts, PTFE non-stick sheets, knobs, control labels, bulbs, fuses, quartz heating elements, baskets, racks, and grease drawers.
- Components that should be replaced when damaged or worn, but have been field-repaired instead [eg. field-welded fry pots].
- Any loss of business or profits.

ADDITIONAL WARRANTIES

Specialty/chain specific versions may also have additional and/or extended warranties.

PRODUCTS	PARTS	LABOR
universal ventless hoods	2 years	1 year
canopy hoods	2 years	1 year
"Cook'n Hold" equipment [HW10, HWSMP, LLSC7, LLSC7WA, LLSC11, and LLSC11WA]	2 years	1 year
cast iron grates, burners, and burner shields	1 year	
original Wells parts sold to repair Wells equipment	90 days	
Service First	1 year	

TABLE OF CONTENTS

WARRANTY	
SPECIFICATIONS	1 - 3
FEATURES & OPERATING CONTROLS	4
PRECAUTIONS & GENERAL INFORMATION	5
AGENCY LISTING INFORMATION	5
INSTALLATION	6
OPERATION	8
CLEANING INSTRUCTIONS	10
TROUBLESHOOTING SUGGESTIONS	12
MAINTENANCE INSTRUCTIONS	13
MODEL NUMBER IDENTIFICATIONS	14
EXPLODED VIEW & PARTS LIST	15 - 25
WIRING DIAGRAM	26 - 35
PARTS & SERVICE	36
CUSTOMER SERVICE DATA	37

INTRODUCTION

Thank You for purchasing this Wells Manufacturing appliance.

Proper installation, professional operation and consistent maintenance of this appliance will ensure that it gives you the very best performance and a long, economical service life.

This manual contains the information needed to properly install this appliance, and to use and care for the appliance in a manner which will ensure its optimum performance.

SPECIFICATIONS (Infinite)

MODEL	VOLTS	WATTS	AMPS 3 ϕ			AMPS1 ϕ
			L1	L2	L3	
MOD200, D, DM	208V	1800W	-	-	-	8.7A
	240V	2400W	-	-	-	10.0A
MOD300, D, DM	208V	2700W	7.5A	7.5A	7.5A	13.0A
	240V	3600W	8.7A	8.7A	8.7A	15.0A
MOD400, D, DM	208V	3600W	11.2A	11.2A	7.5A	17.3A
	240V	4800W	13.0A	13.0A	8.7A	20.0A
MOD500, D, DM	208V	4500W	15.0A	11.2A	11.2A	21.6A
	240V	6000W	17.0A	13.0A	13.0A	25.0A

SPECIFICATIONS (Thermostat)

MODEL	VOLTS	WATTS	AMPS 3 ϕ			AMPS1 ϕ
			L1	L2	L3	
MOD-200T MOD-200TD MOD-200TDM	208 VAC	2480W	6.0A	6.0A	10.3A	11.9A
	240 VAC	3300W	6.9A	6.9A	11.9A	13.8A
MOD-200TDM-K	208 VAC	2480W	6.0A	6.0A	10.3A	11.9
	240 VAC	3300W	6.9A	6.9A	11.9A	13.8
MOD-200TN MOD-200TDN MOD-200TDMN	208 VAC	2480W	6.0A	6.0A	10.3A	11.9A
	240 VAC	3300W	6.9A	6.9A	11.9A	13.8A
MOD-227TD MOD-227TDM	208 VAC	2480W	6.0A	6.0A	10.3A	11.9A
	240 VAC	3300W	6.9A	6.9A	11.9A	13.8A
MOD-300T MOD-300TD MOD-300TDM	208 VAC	3725W	10.3A	10.3A	10.3A	17.9A
	240 VAC	4950W	11.9A	11.9A	11.9A	20.6A
MOD-300TN MOD-300TDN MOD-300TDMN	208 VAC	3725W	10.3A	10.3A	10.3A	17.9A
	240 VAC	4950W	11.9A	11.9A	11.9A	20.6A
MOD-327TDM	208 VAC	3725W	10.3A	10.3A	10.3A	17.9A
	240 VAC	4950W	11.9A	11.9A	11.9A	20.6A
MOD-400T MOD-400TD MOD-400TDM	208 VAC	4960W	14.5A	14.5A	9.8A	23.8A
	240 VAC	6600W	17.8A	17.8A	11.3A	27.5A
MOD-427TDM	208 VAC	4960W	14.5A	14.5A	9.8A	23.8A
	240 VAC	6600W	17.8A	17.8A	11.3A	27.5A

MOD200TDM/AF, MOD200TDAF	208 VAC	2480W	6.0A	6.0A	10.3A	11.9A
	240 VAC	3300W	6.9A	6.9A	11.9A	13.8A
MOD200TDMN/AF	208 VAC	2480W	6.0A	6.0A	10.3A	11.9A
	240 VAC	3300W	6.9A	6.9A	11.9A	13.8A
MOD227TDM/AF	208 VAC	2480W	6.0A	6.0A	10.3A	11.9A
	240 VAC	3300W	6.9A	6.9A	11.9A	13.8A
MOD300TDM/AF, MOD300TDAF	208 VAC	3725W	10.3A	10.3A	10.3A	17.9A
	240 VAC	4950W	11.9A	11.9A	11.9A	20.6A
MOD300TDMN/AF/F6	208 VAC	3725W	10.3A	10.3A	10.3A	17.9A
	240 VAC	4950W	11.9A	11.9A	11.9A	20.6A
MOD327TDM/AF	208 VAC	3725W	10.3A	10.3A	10.3A	17.9A
	240 VAC	4950W	11.9A	11.9A	11.9A	20.6A
MOD400TDM/AF, MOD400TDAF	208 VAC	4960W	14.5A	14.5A	9.8A	23.8A
	240 VAC	6600W	17.8A	17.8A	11.3A	27.5A
MOD427TDM/AF	208 VAC	4960W	14.5A	14.5A	9.8A	23.8A
	240 VAC	6600W	17.8A	17.8A	11.3A	27.5A
MOD500TDM/AF, MOD200TDAF	208 VAC	6200W	19.5A	14.6A	14.6A	29.8A
	240 VAC	8250W	22.1A	16.9A	16.9A	34.4A
MOD527TDM/AF	208 VAC	6200W	19.5A	14.6A	14.6A	29.8A
	240 VAC	8250W	22.1A	16.9A	16.9A	34.4A

SPECIFICATIONS (Digital)

MODEL	VOLTS	WATTS	AMPS 3 ϕ			AMPS1 ϕ
			L1	L2	L3	
M200CE	208/240V	2,475 / 3,312	6.0 / 6.9	6.0 / 6.9	10.3 / 11.9	11.9 / 13.8
M200E						
M200CED						
M200ED						
M200CED6						
M200ED6						
M200CEDM						
M200EDM						
M200CEDM6						
M200EDM6						
M200CEAF						
M200EAF						
M200CEAF6						
M200EAF6						
M227CEDM						
M227EDM						
M227CEDM6						
M227EDM6						
M227CEAF						
M227EAF						
M227CEAF6						
M227EAF6						
M300E	208/240V	3,733 / 4,944	10.3 / 11.9	10.3 / 11.9	10.3 / 11.9	17.9 / 20.6
M300E6						
M300EAF						
M300EAF6						
M300ED						
M300ED6						
M300EDM						
M300EDM6						
M327EAF						
M327EAF6						
M327EDM						
M327EDM6						
M300EAFTH						
M400E	208/240V	4,950 / 6,600	14.5 / 17.8	14.5 / 17.8	9.8 / 11.3	23.8 / 27.5
M400E6						
M400EAF						
M400EAF6						
M400ED						
M400ED6						
M400EDM						
M400EDM6						
M427EAF						
M427EDM						
M427EDM6						
M500E	208 / 240V	6,198 / 8,256	19.5 / 22.1	19.5 / 22.1	19.5 / 22.1	29.8 / 34.4
M500E6						
M500EAF						
M500EAF6						
M500ED						
M500ED6						
M500EDM						
M500EDM6						
M527EAF						
M527EAF6						
M527EDM						
M527EDM6						

FEATURES & OPERATING CONTROLS

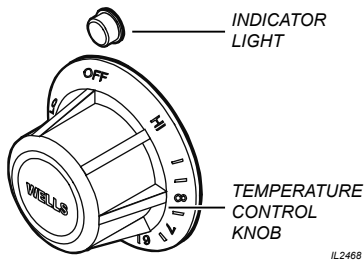

IMPORTANT:

DO NOT LEAVE ON
"PREHEAT"

Unit may cycle on hi-limit control, leading to premature failure of the hi-limit controls device.

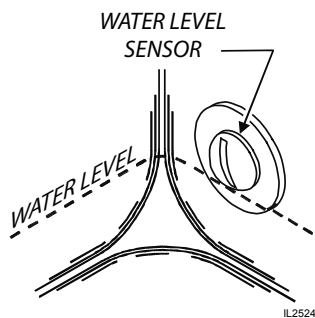
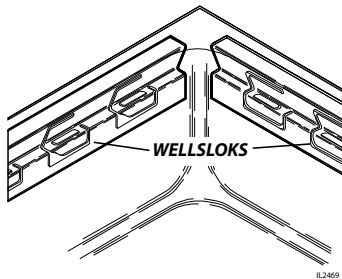

A. THERMOSTAT

1. On thermostatically controlled warmers, power is applied to the heating element according to the control knob position and the actual temperature at the temperature sensing thermobulb.
2. The desired temperature is controlled by rotating the temperature control knob. The knob has a numeric scale, where higher numbers correspond to higher temperature.
3. On warmers equipped with an indicator light, the light will glow when the thermostat is calling for heat (i.e. the element is energized).
4. The TEMPERATURE CONTROL KNOB will rotate approximately 300°, and will reach a "stop" at both ends. The OFF position is marked.

NOTE: The dial position is an indication of the temperature setting. Actual temperature will vary depending upon the type of product and food consistency.

A. INFINITE SWITCH

1. On INFINITE SWITCH CONTROLLED warmers, power is applied to the heating element based on the control knob position, which varies the duty cycle of the heating element.
2. The desired temperature is controlled by rotating the TEMPERATURE CONTROL KNOB. The knob may have a numeric scale, where higher numbers correspond to higher temperature. LO is the lowest temperature setting; PREHEAT is a "continuous on" setting. Infinite switch controlled warmers are equipped with a hi-limit device to prevent overheating. The hi-limit will self-reset after the warmer has cooled.
3. On warmers equipped with an INDICATOR LIGHT, the light will glow when the infinite switch is in any position other than OFF.
4. The TEMPERATURE CONTROL KNOB will rotate without stopping, with PREHEAT and OFF having obvious detents. The OFF position is a "positive" OFF (i.e. the switch is positively held in the open position).

NOTE: An infinite switch controls temperature by varying the ratio of "on" time to "off" time. Thus, no temperature sensing device is required.

B. MOUNTING

1. MOD-series built-in warmers may be equipped with well sloks, uniquely designed turnout tabs which help secure the warmer top flange to the countertop.
2. See the Installation Instructions, supplied with the particular appliance.

C. DRAINS

1. Models with a "D" (e.g. M200TD) have drains for each pan, with each pan having an individual drain valve.
2. Models with a "DM" units (e.g. M200TDM) have the individual drain lines manifolded together, with a single drain valve for the entire manifold.

D. AUTOFILL

1. On AUTOFILL units, water level is automatically fed into the "master" pan whenever that pan's thermostat is ON.
2. Water level is sensed by a WATER LEVEL PROBE in the "master" pan.

PRECAUTIONS AND GENERAL INFORMATION

This appliance is intended for use in commercial establishments only.

This appliance is intended to hold pre-heated food for human consumption. No other use is recommended or authorized by the manufacturer or its agents.

Operators of this appliance must be familiar with the appliance use, limitations and associated restrictions. Operating instructions must be read and understood by all persons using or installing this appliance.

Cleanliness of this appliance is essential to good sanitation. Read and follow all included cleaning instructions and schedules to ensure the safety of the food product.

Disconnect this appliance from electrical power before performing any maintenance or servicing.

This appliance is not jet stream approved. Do not direct water jet or steam jet at this appliance, or at any control panel or wiring. Do not splash or pour water on, in or over any controls, control panel or wiring.

Exposed surfaces of this appliance can be hot to the touch and may cause burns.

Do not operate this appliance if the control panel is damaged. Call your Authorized Wells Service Agent for service.

The technical content of this manual, including any wiring diagrams, schematics, parts breakdown illustrations and/or adjustment procedures, is intended for use by qualified technical personnel.

Any procedure which requires the use of tools must be performed by a qualified technician.

This manual is considered to be a permanent part of the appliance. This manual and all supplied instructions, diagrams, schematics, parts breakdown illustrations, notices and labels must remain with the appliance if it is sold or moved to another location.

This appliance is made in the USA. Unless otherwise noted, this appliance has American sizes on all hardware.



WARNING: SHOCK HAZARD

All servicing requiring access to non-insulated electrical components must be performed by a factory authorized technician.

DO NOT open any access panel which requires the use of tools. Failure to follow this warning can result in severe electrical shock.



CAUTION: RISK OF DAMAGE

DO NOT connect or energize this appliance until all installation instructions are read and followed. Damage to the appliance may result if these instructions are not followed.



CAUTION: HOT SURFACE

Exposed surfaces can be hot to the touch and may cause burns.

AGENCY LISTING INFORMATION

Refer to the product nameplate for the specific appliance for agency listings. In general:

This appliance conforms to NSF Standard 4 for sanitation only if installed in accordance with the supplied Installation Instructions.

UL Listed warmers are U Listed under UL File E6070.



STD 4



E6070

UL Listed Warmers

INSTALLATION

NOTE: DO NOT discard the carton or other packing materials until you have inspected the appliance for hidden damage and tested it for proper operation. Refer to SHIPPING DAMAGE CLAIM PROCEDURE on the inside front cover of this manual.



WARNING: RISK OF INJURY

Installation procedures must be performed by a qualified technician with full knowledge of all applicable electrical and plumbing codes. Failure can result in personal injury and property damage.



CAUTION FIRE HAZARD

Avoid storing flammable or combustible materials in, on or near the appliance.

IMPORTANT: For warmers installed in plastic counter tops, the counter material must be protected from the heat of the warmer in order to prevent discoloration and/or deterioration. Wellsloks are not suitable for this purpose. The installer should contact the manufacturer or distributor of the countertop material for specific instructions.

IMPORTANT: Wellslok Extension Kits must be used ONLY with UL Listed warmers approved for installation in wood counter tops. Refer to the Installation Instructions provided with the warmer.

UNPACKING & INSPECTION

Carefully remove the appliance from the carton. Remove all protective plastic film, packing materials and accessories from the Appliance before connecting electrical power or otherwise performing any installation procedure.

Carefully read all instructions in this manual and the Installation Instruction Sheet packed with the appliance before starting any installation.

Read and understand all labels and diagrams attached to the unit.

Carefully account for all components and accessories before discarding packing materials. Store all accessories in a place for later use.

INSTALLATION NOTES

1. Installation and start up of built-in warmers MUST be performed by an authorized installation company.
2. It is the responsibility of the installer to verify that this warmer installation is in compliance with the specifications listed in this manual and on the specification sheet provided.
3. It is the RESPONSIBILITY OF THE INSTALLER to check with the authority having jurisdiction, in order to verify that this warmer installation is in compliance with local code requirements.
4. Water supply and drain installation must meet all applicable local, state and federal plumbing codes and ordinances.
5. Refer to Installation Instructions included with the warmer for Underwriters Laboratories conditions of acceptability, electrical requirements and other installation concerns.

BUILT-IN WARMERS

1. This is a GENERAL GUIDE. For specific cutout dimensions and other installation details, refer to the Installation Instructions supplied with the warmer.
2. Cutout dimensions for warmer units and control panels are listed on the Installation Instructions provided with the warmer.

NOTE: Cutout dimensions are different for auto-fill and non auto-fill units, control panels, and for wood and metal counters. Verify the dimensions are correct for the installation before making the cutout. Specific cutout specifications are list on the installation sheet included with the unit.

3. For "top-mounted" warmers (i.e. warmers mounted from above the counter top):
 - a. Verify that provided sealants are applied to the underside of the warmer top flange prior to setting the unit into the cutout.
 - b. After installation, verify that the tabs on the Wellsloks are turned out to lock the warmer into the counter.
 - c. Apply a thin bead of food-grade silicone sealant around the flange to seal it to the counter.
 - d. Wellslok extension kits are available for installing warmers in counter tops where the standard Wellslok would not normally reach. The extension kit will adapt to counter tops up to 1¼" thick.

INSTALLATION

ELECTRICAL INSTALLATION

1. Refer to the product nameplate. Verify the electrical service power. Voltage and phase must match the nameplate specifications. Wiring the warmer to the wrong voltage can severely damage the unit or cause noticeably decreased performance.
2. Available electrical service amperage must meet or exceed the specifications listed on the specification sheet provided with the warmer.
3. Warmer and control unit must be connected to an appropriate building ground. Ground connection will be marked "GND" or "⏚".

NOTE: Wire gauge, insulation type and temperature rating, as well as type, size and construction of conduit, must meet or exceed applicable specifications of local codes and of the National Electrical Code.

PLUMBING INSTALLATION

For use in the State of Massachusetts, this appliance must be installed in compliance with **Massachusetts Fuel Gas and Plumbing Code CMR 248**.

1. **IMPORTANT:** All plumbing installations must be performed by a qualified plumber.
2. For units equipped with a **DRAIN LINE**: Some jurisdictions may require an approved air gap or other back-flow prevention device in the drain. It is the responsibility of the plumber to determine such requirement, to provide and properly install the required device.
3. **AUTOFILL** units are equipped with a **DRAIN LINE**: Some jurisdictions may require an approved air gap or other back-flow prevention device in the drain. It is the responsibility of the plumber to determine such requirement, to provide and properly install the required device.
4. For **AUTOFILL** units: Some jurisdictions may require an approved back-flow preventer in the water supply line. It is the responsibility of the plumber to determine such requirement, and to provide and properly install the required device.
Autofill supply must be connected to a COLD WATER line only.

IMPORTANT:

While local plumbing codes may allow the use of pvc, cpvc, abs or other plastic pipe for drain connections. **DO NOT** attach a plastic drain to the bottom of the food warmer. These units will contain water with temperatures in excess of 180°F (82°C) and localized metal temperatures in excess of 275°F (135°C). Failure to follow these directions may result in personal injury and property damage.

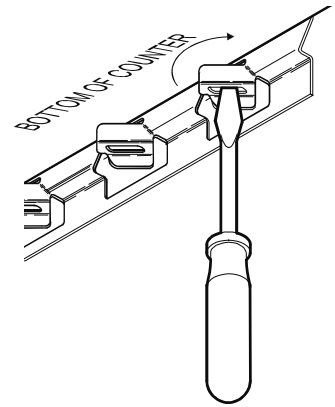

NOTE: Damage caused by leaks due to improper installation is NOT covered by warranty.

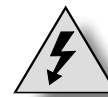

CAUTION: SHOCK HAZARD

The ground lug of this appliance must be connected to a suitable building ground.

IMPORTANT: Contact a licensed electrician to install and connect electrical power to the appliance.

IMPORTANT: Damage due to being connected to the wrong voltage or phase is NOT covered by warranty.

IMPORTANT: Electrical installation other than as specified on the specification sheet will void the UL listing, and may void the warranty.

NOTE: Plumb connections must be made in compliance with all Federal, State and Local Plumbing Codes and Ordinances.

OPERATION



CAUTION: HOT SURFACE

Exposed surfaces can be hot to the touch and may cause burns.



CAUTION: SHOCK HAZARD

DO NOT splash or pour water onto control panel or wiring.

Always use an inset.

DO NOT place food directly into the warmer.

Always pour hot water into the warmer before it is preheated.

DO NOT pour water into a dry, heated warmer. This may damage the unit.

DO NOT put ice into a warmer pan. This will cause condensation on the inside of the warmer. Damage caused by condensation is **NOT** covered by warranty.

Stir thick food items frequently to keep food heated uniformly. Keep insets covered to maintain food quality and temperature.

DO NOT use **AUTOFILL** warmers in the dry mode. This may damage the water level sensor. **NEVER** turn the thermostat **ON** for the pan with the sensor and fill tube unless the entire warmer unit is to be used in the wet mode.

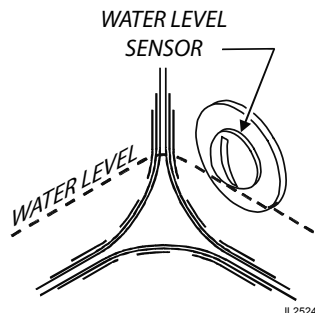

WET OR DRY OPERATION for WARMERS

1. Carefully read the description of the warmer operation on the specification sheet.
2.
 - a. Most warmers are designed for WET OR DRY operation.
 - b. Warmers may be used wet, or may be used dry. However warmers may **NOT** be used wet-to-dry or dry-to-wet unless they have been allowed to cool to room temperature between the change in wet or dry operation.
 - c. Wells Manufacturing recommends operating WET for consistent food heating.
 - d. If your wet-operation warmer is allowed to run dry, turn it OFF and allow to cool to room temperature before adding water.
3. If the warmer is to be used for WET operation, add approximately 1" of hot tap water before turning the warmer on. Use of hot water will allow a faster preheat.
 - a. Check the water level frequently and add hot water as necessary to prevent the warmer from running dry. Do not add water to the warmer if it has run dry.
 - b. If your wet-operation warmer is allowed to run dry, turn it OFF and allow to cool to room temperature before adding water.
4. Damage caused by allowing a wet-operation warmer to run dry, is **NOT** covered by warranty. Damage caused by adding water to a dry warmer when hot is **NOT** covered by warranty.

PRE-HEATING THE WARMER

1. Place desired pan(s) or inset(s) with appropriate adapter top on warmer.
 - a. Insets are available as accessories in 2½ qt., 4qt., 7 qt., and 11 qt. sizes with lids and adapter tops.
 - b. For dry operation, a 6" deep pan or inset is recommended.
2. Turn temperature control to HI or highest temperature setting.
3. Allow warmer to preheat for approximately 30 minutes, then set the control for the desired temperature. Be sure to keep the warmer covered during preheat and operation.

AUTOFILL WARMERS

1. Autofill warmers sense water level by a sensor placed at the proper level. For manifolded autofill warmers, the water level sensor / fill tube is in one pan only, normally in the far left pan.
2. Water fills the pan through an inlet tube. For manifolded autofill warmers, the fill tube is normally in the far left pan. All other sections fill at the same time through the drain manifold.
3. The autofill function is active only when the thermostat for the pan with the water level sensor is turned ON.
4. Make sure the drain valve is fully closed before turning any t-stats ON.
5. The autofill function is only activated when the far left thermostat is turned ON. For manifolded autofill warmers, be sure to turn far left thermostats ON before turning any other control ON, to avoid heating a dry pan.

OPERATION (continued)

AUTOFILL WARMERS continued

6. DO NOT use autofill warmers in the dry mode. This may damage the water level sensor probe. NEVER turn the thermostat ON for the pan with the probe and fill tube unless the entire warmer unit is to be used in the wet mode.
7. Clean water level sensor daily to maintain water level in warmer.

OPERATION

1. Always use an inset. **DO NOT** place food directly into the warmer.
2. Check water level in wet-operation warmer frequently during use. Running warmers dry will lower the temperature of the food in the insert pan, and may damage the warmer.
3. Alternating between wet and dry operation in any individual warmer is **NOT** recommended.
4. **DO NOT** use metal tools, steel wool, or caustic or abrasive cleanser to clean warmer pan.

WARMERS WITH MANIFOLDED DRAIN

1. Manifolded warmers have a single drain valve.
2. Water poured into any one section will seek the same water level with all sections on the manifold.
3. Make sure the drain valve is fully closed before filling warmer.

Digital Control Operation

This control will provide close regulation of the temperature in the basin and give an indication of the air temperature surrounding the food container. The temperature is adjustable from 100° to 200°F. Pressing the ON/OFF button of the temperature control activates the heating circuit. The setpoint is displayed by pressing and holding the TEMP button. Adjust the regulated temperature by pressing the + or – buttons while holding the TEMP button down. The actual basin temperature is displayed when no buttons are pressed and the control is in the ON mode. The dot in the lower corner of the display indicates when the control is calling for heat.

When provided the master power switch controls the heating circuit and the automatic water fill control. Turn “OFF” the power switch when draining or cleaning the unit.

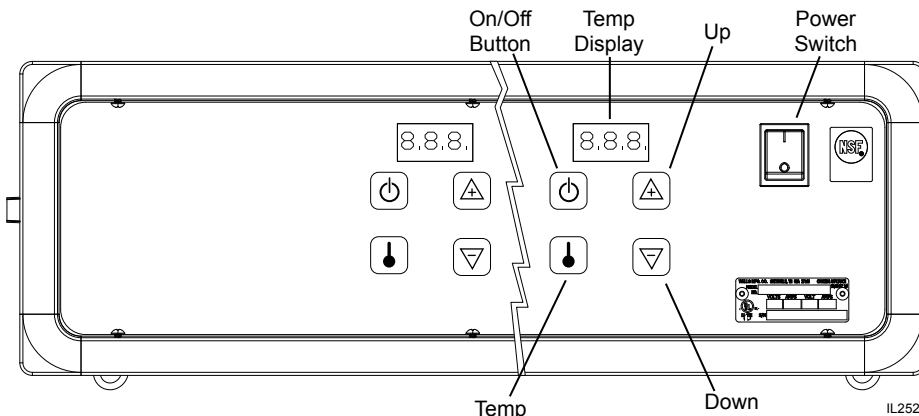

ABOVE: Digital Electronic Control Panel (certain models only)

CLEANING INSTRUCTIONS



CAUTION: SHOCK HAZARD

DO NOT splash or pour water into or over any control panel or wiring.



CAUTION: SHOCK HAZARD

Disconnect warmer from electric power before cleaning



CAUTION: BURN HAZARD

Allow warmer to cool completely before cleaning.

DAILY CLEANING INSTRUCTIONS

PREPARATIONS: Turn control knob(s) to OFF. Allow warmer to cool before proceeding.
Remove any insets, pans and/or adapter tops.
Drain or remove water from well if used for wet operation.

FREQUENCY: Minimum - daily.

TOOLS: Mild Detergent
Solution: 10 Parts Warm Water to 4 Parts Vinegar
Plastic Scouring Pad
Clean Cloth or Sponge
Food-Grade Silicone Sealant

1. Wipe entire unit down using a clean cloth or sponge and mild detergent.
2. Use a plastic scouring pad to remove any hardened food particles or mineral deposits.
IMPORTANT: DO NOT use steel wool for cleaning.
3. Rinse warmer thoroughly with a vinegar and water solution to neutralize all detergent cleanser residue.
4. Inspect warmer flange-to-counter seal. Reseal with food-grade silicone sealant if necessary. Failure to do so may allow grease and water to leak into insulation and heating element, causing a potential fire and/or electric shock hazard.
5. Inspect warmer tank for damage. Damage to the outer body may allow grease and water to leak into insulation and heating element, causing a potential fire and/or electric shock hazard. Contact your Authorized Wells Service Agency to inspect warmer if water or grease contamination is suspected.
6. Close drain valve. Add proper amount of warm water. Turn control knob(s) ON and check for proper operation.

CLEANING INSTRUCTIONS

WEEKLY CLEANING INSTRUCTIONS

PREPARATIONS: Remove any insets, pans and/or adapter tops. Drain or remove water from well if used for wet operation.

FREQUENCY: Weekly, or whenever lime or scale is seen accumulating on the sides of the warmer pans.

TOOLS: Commercial Delime Cleaner
Plastic Scouring Pad
Clean Cloth or Sponge



CAUTION: CHEMICAL BURN HAZARD

Deilimng chemicals may be caustic. Wear appropriate personal protective equipment. Follow cleaner manufacturer's instructions for safest use.

1. Add water to pans until water is at normal operating level (1" - 1 1/2" deep) or covers accumulated scale.
2. Heat water to maximum temperature (190°F or higher).
3. Pour contents of one package of commercial delime cleaner into each warmer pan. Stir to dissolve cleaner. Turn heat control OFF. Cover pans.
4. Allow solution to soak at least one hour, or overnight for heavy scale buildup.
5. Drain hot water from pans. Scrub with a plastic scouring pad. Rinse thoroughly with hot water, then dry.
6. Refill pans with hot tap water and resume operation.
7. Heavy scale buildup may require additional treatments.

TROUBLESHOOTING SUGGESTIONS

SYMPTOM	POSSIBLE CAUSE	SUGGESTED REMEDY
No power to warmer	Circuit breaker off or tripped	Reset circuit breaker
Warmer will not heat	Temperature control not set	Set control to desired temperature
Warmer trips circuit breaker	Wet insulation	Verify flange-to counter seal is sound, or reseal with food-grade silicone sealant
	Pan leaking or other internal damage	Contact your Authorized Wells Service Agency for repairs
	Internal damage	Contact your Authorized Wells Service Agency for repairs
Warmer slow to heat	Mineral deposits on pan acting as a insulator	Clean pan(s) with delime cleaner
	Wired to wrong voltage	Verify supply voltage - must match voltage on warmer nameplate
Drain-equipped unit will not hold water	Drain valve not fully closed	Check drain valve for debris and close fully
	Drain valve damaged or pan(s) leaking	Contact your Authorized Wells Service Agency for repairs
Auto-fill unit overflows	Water level sensor dirty	Clean water level sensor
	Internal damage	Contact your Authorized Wells Service Agency for repairs
Auto-fill unit does not fill	Water supply turned off or restricted	Be sure water supply is turned on and water supply hose is not pinched or twisted
	Bad Probe or other Internal Damage	Contact your Authorized Wells Service Agency for repairs
One or more pans of an auto-fill unit do not fill	Blocked drain manifold	Clean drain manifold

There are no user-serviceable components in this appliance.
 In all instances of damage or malfunction, contact your Authorized Wells Service Agency for repairs.

MAINTENANCE INSTRUCTIONS

CARE OF STAINLESS STEEL

Stainless steel is a marvelous material: strong, lustrous and low maintenance. With a minimum of care, it will normally retain its beauty and durability for the life of the equipment. In some applications, however, special care is required in order to maintain stainless steel's special properties.

External components, such as cabinets and control panels, are finished with a grain pattern. This pleasing finish is best maintained by cleaning with a non-abrasive cleanser applied with a soft cloth. Rub only in the direction of the grain. In the absence of visible grain, rub only along the longest axis of the appliance.

Restore stainless steel's luster by applying a polish specifically made for stainless steel. Spray on, wipe off with a soft cloth, rubbing in the direction of the grain.

Never use metal implements, wire brushes, abrasive scratch pads or steel wool to clean stainless steel.

Warmer pans, insets and other vessels are subject to a harsher environment. Wells Manufacturing uses an very high quality stainless steel (#304DDQ) for our food warmer pans. Even the highest quality stainless steel, however, is mostly iron, and will rust, pit and corrode under the following conditions:

- **Poor Water Quality:** Hard water (water with a high content of dissolved minerals) will leave mineral deposits when allowed to dry. Calcium (lime) can buildup on heated surfaces, even under water. If left unattended, hard water spots and lime buildup can lead to rusting, corrosion and pitting.
- **Contact with Chlorides:** Chlorides (specific compounds of chlorine) are found in food, table salt and many cleansers. Chlorides can attack the surface of stainless steel, resulting in corrosion and pitting.

Keep your stainless steel warmers clean and free from calcium buildup.

Use alkaline, alkaline chlorinated or non-chloride cleanser.

Use citric acid-based cleaners to remove calcium deposits.

For additional information, please read the NAFEM Stainless Steel Equipment and Cleaning Guide. Contact NAFEM at :

North American Association of Food Equipment Manufacturers

401 N. Michigan Avenue

Chicago, Illinois 60611-4267

(312) 644-6610

MODEL NUMBER IDENTIFIER

Built-In Modular Warmer Identifier

M300CTDNMAF6

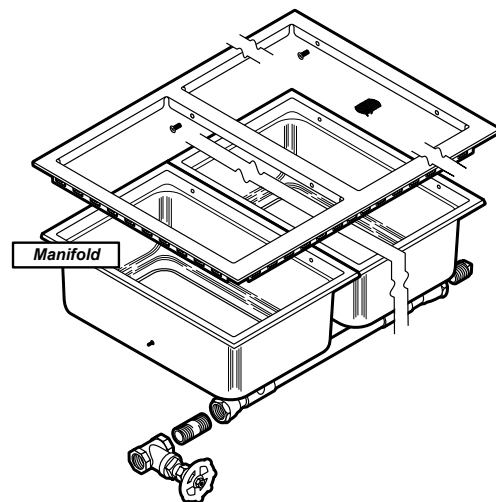
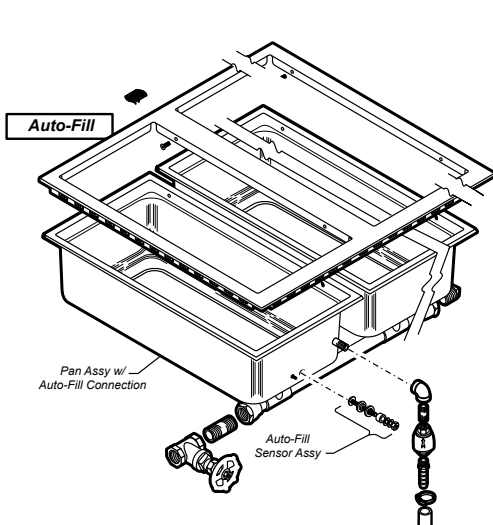
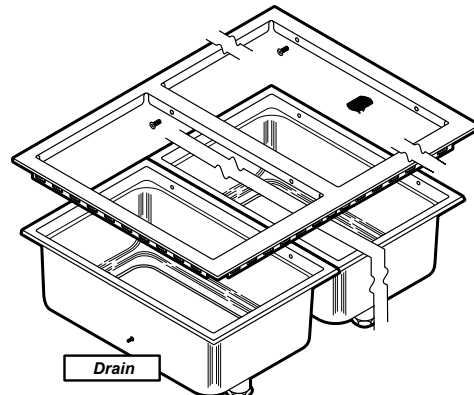
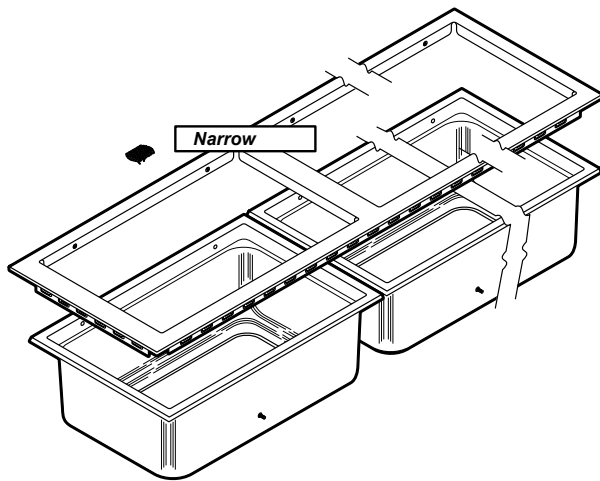
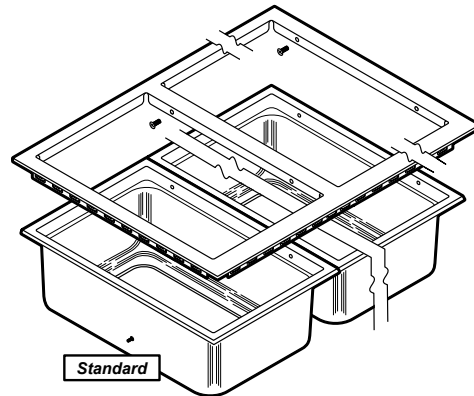
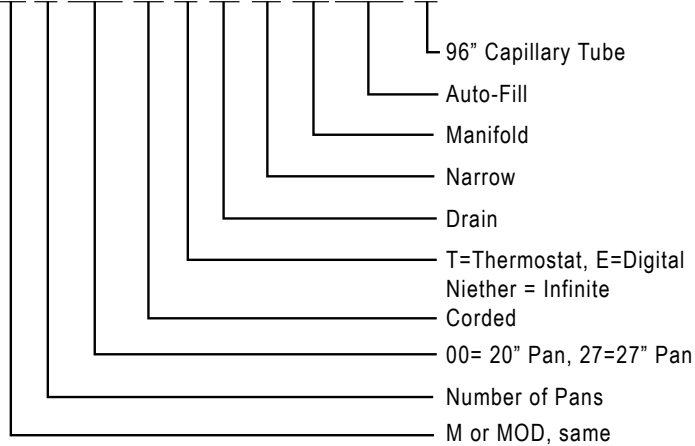

EXPLODED VIEW & PARTS LIST

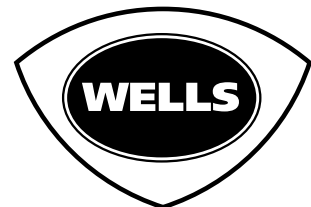
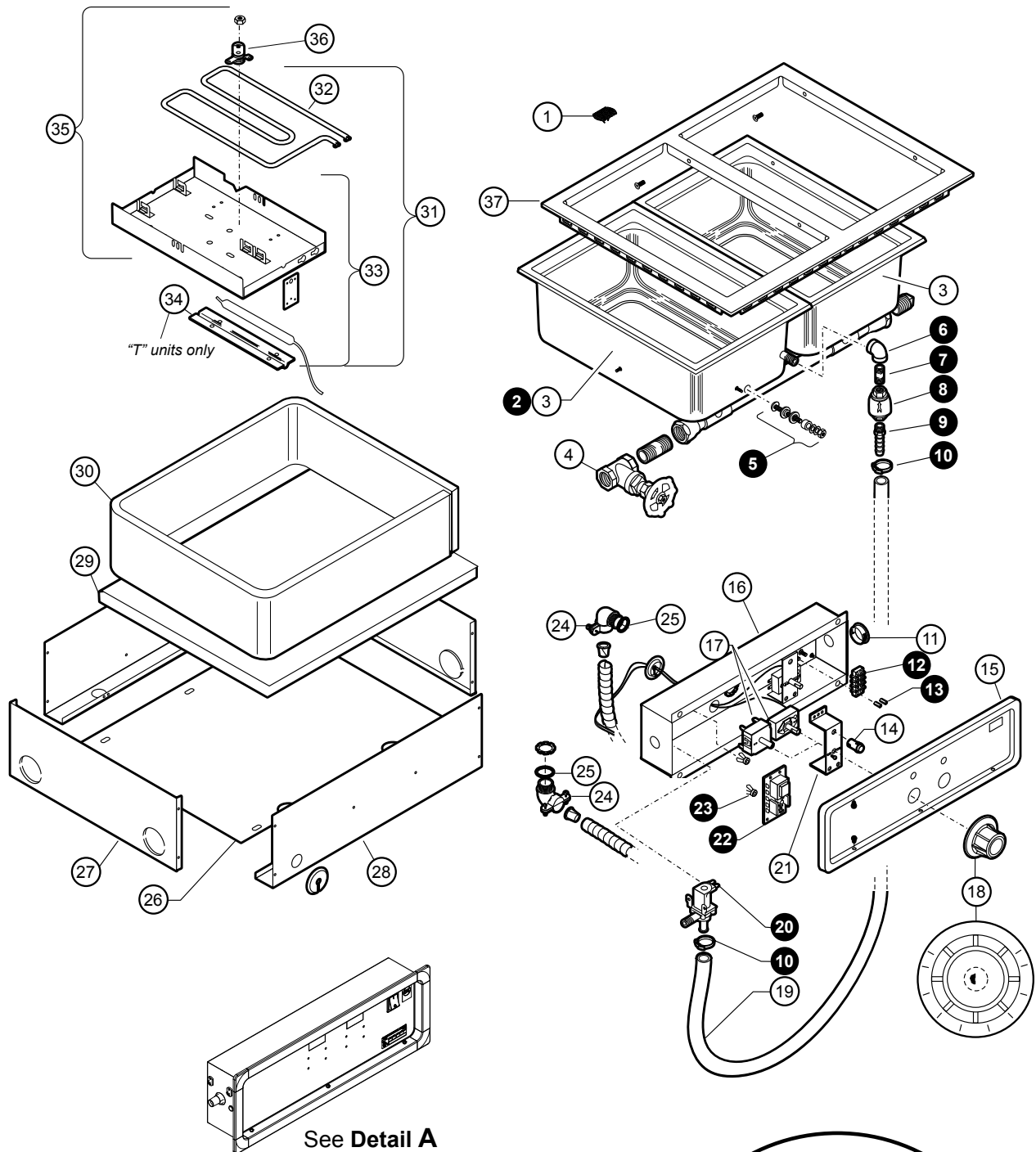

M011C.02 2M-Z16298 Owners Manual for Built-In Well Modular Warmers

BUILT-IN MODULAR WARMERS

SK2615, Rev. A, 8/01/13

PARTS LIST: M200-227 SERIES

Model: Modular Warmers M200-227T, TD, TDM, TDMAF, TN, M200-227E, CE, ED, EDM, EDMAF, EN

Fig No	Part No	Description	Qty	Application
1	P2-31869	SCREEN DRAIN ASSY WARMER	2	DRAIN UNITS
2	P2-Z14636	PAN ASSY 12X20 EAF W/TEE	1	M200 DIGITAL
	P2-Z14647	PAN ASSY 12X27 EAF		M227 DIGITAL
	P2-WL0064	PAN ASSY W/ELBOW MODTDMN		M200 T-STAT NARROW
	WS-503893	PAN ASSY 200-500TDM A/F		M200 T-STAT & INFINITE
	WS-504101	PAN ASSY 12X27 AF		M227 T-STAT
3	P2-Z14639	PAN ASSY 12X20 E	2	M200 DIGITAL
	P2-Z14637	PAN ASSY 12X20 ED w/DRAIN		M200 DIGITAL DRAIN
	P2-Z14638	PAN ASSY 12X20 EDM		M200 DIGITAL DRAIN, MANIFOLD
	P2-Z14646	PAN ASSY 12X27 EDM		M227 DIGITAL, DRAIN, MANIFOLD
	P2-WL0063	PAN ASSY AF MODTDMN	1	M227 DIGITAL, AUTOFILL
	WS-55742	PAN W/DRAIN 200-500DM/TDM	1	M200 T-STAT, AUTOFILL
	WS-55741	PAN W/O DRAIN 200-500 / T	2	M200 T-STAT & INFINITE, DRAIN, MANIFOLD
	WS-53201	PAN W/DRAIN 200-500 /TD		M200 T-STAT & INFINITE
WS-500700	PAN ASSY 12X27 TDM	M200 T-STAT & INFINITE, DRAIN		
4	2V-35609	VALVE 1 IN GATE BRONZE	1	M227 T-STAT, DRAIN, MANIFOLD
5	WS-503713	PROBE ASSY, SS AUTOFILL WRMR	1	MANIFOLD UNITS
6	2K-48198	ELBOW 3/8 X 90DEG BRASS	1	AUTOFILL UNITS
7	2K-48197	NIPPLE 3/8 NPT X 2 BRASS	1	AUTOFILL UNITS
8	2V-47650	VALVE ANTISYPHON 3/8	1	AUTOFILL UNITS
9	2K-47662	FTG STR BRS 3/8NPT X3/8IN	1	AUTOFILL UNITS
10	2C-46591	CLAMP HOSE 5/8	2	AUTOFILL UNITS
11	2K-31040	BUSHING HEYCO 7/8 OD	1	THERMOSTAT UNITS
12	WS-50131	TERM BLOCK KIT (RETRO 30131)	1	INFINITE & AUTOFILL UNITS
13	2C-41974	NUT 8-32 HEX 7/8 LONG ALU	2	AUTOFILL UNITS
14	2J-30385	LIGHT SIGNAL GLO DOT RED	2	INFINITE UNITS
	2J-35687	LIGHT SIGNAL GLO DOT		T-STAT UNITS
15	P2-Z12288	PANEL, CONTROL	1	T-STAT & INFINITE UNITS NON-AF
	P2-Z19780	CONTROL PANEL		MOD227TDM-K
	P2-Z12589	PANEL, CONTROL MOD 200/400	1	AUTOFILL UNITS
16	E7-49046	BOX OUTLET MOD WARM	1	T-STAT & INFINITE UNITS NON-AF
	P2-Z19779	HOUSING CONTROL		MOD227TDM-K
	P2-48175	BOX OUTLET MOD200/400TDM		AUTOFILL UNITS
17	2T-38968	THERMO K TYPE	2	T-STAT UNITS
	2T-46551	THERMO CTRL 96IN CAP		T-STAT UNITS w/ 96IN CAPILLARY
	2T-45917	THERMO CTRL W/AUX WARMERS		T-STAT UNITS, AUTOFILL
	2E-30570	SWITCH INFINITE, 120V	2	INFINITE UNITS, 120V
	2E-30562	SWITCH INFINITE, 240V	2	INFINITE UNITS, 240V
18	2R-44373	KNOB CONTROL ASSY WARMERS	2	INFINITE UNITS
	2R-40498	KNOB ASSY MOD 100DT		T-STAT UNITS
20	2E-46529	SOLENOID VALVE 1/4NPT 240	1	AUTOFILL UNITS
21	P2-40843	BRKT MTG THERMO INFINITE	2	T-STAT & INFINITE UNITS
	P2-48176	BRKT THERMO MOD200TDM AUT		T-STAT AUTOFILL
22	2E-306865	CONTROL LIQ LEVEL 208/240	1	AUTOFILL UNITS
23	2I-40034	GROMMET SCREW T4	4	AUTOFILL UNITS

PARTS LIST: M200-227 SERIES

Model: Modular Warmers M200-227T, TD, TDM, TDMAF, TN, M200-227E, CE, ED, EDM, EDMAF, EN

Fig No	Part No	Description	Qty	Application
24	2K-33996X	FTG FLEX CONDUIT 90X3/8	2	
25	2I-Z12311	GASKET-FIBER WASHER	2	
26	P2-300712	COVER BOT M227-427TDM/AM	2	M227
	P2-35004	COVER BOTTOM 200 SERIES	1	M200
27	P2-303359	SHROUD SIDE MODS ROHS	2	M200
	P2-300593	SHROUD SIDE MOD TDN		M200 NARROW
28	P2-Z15948	SHROUD, FRONT UNIVERSAL	1	M200, 227
	P2-33909	SHROUD FRONT/REAR MOD200		
	P2-Z19777	SHROUD, FRONT 227TDM-KFC		
	P2-300592	SHROUD FRT/RR MOD200TDN	2	M200 NARROW
29	2H-36050	INSUL FG .6 MICRO 1/36	SOLD BY FOOT	
30	2H-36196	INSUL FG .6 MICRO 1X45	SOLD BY FOOT	
31	P2-WL0082	PAN ELEM ASSY	2	M200 DIGITAL
	P2-WL0096	PAN ELEM ASSY MOD 227-527		M227 DIGITAL
	WS-503843	KIT PAN ELEM W/ELEMENT 208/240		M200 T-STAT
	WS-503701	KIT ELEM PAN W/ELEMENT		M200 T-STAT NARROW
	WS-503840	KIT ELEM PAN W/ELEMENT		M227 T-STAT
32	WS-50396	ELEM 120V 1200W	2	M200 INFINITE, 120V
	WS-50398	ELEM 240V 1200W M P		M200 INFINITE, 240V
	2N-46681UL	ELEM 120V 1650W		M200 T-STAT, 120V
	2N-303375UL	ELEM HEATING 240V 1650W		M200 T-STAT, 240V
	2N-300706UL	ELEM 240V 1650W 12 X 27		M227
33	WS-55707	COVER ELEM MOD WARMER	2	INFINITE UNITS
	WS-503842	KIT ELEM PAN W/O ELEMENT		M200, T-STAT & DIGITAL
	WS-503370	PAN, ELEMENT MODS		M200 NARROW
	WS-503841	KIT ELEM PAN W/O ELEMENT		M227
34	D8-303352	BRKT THERMO BULB	2	THERMOSTAT UNITS
35	P2-WL0081	PAN ELEM ASSY MOD200-500	2	INFINITE 208/240V
36	WS-50374	THERMO, HI-LIMIT, SFTY, 550F	2	INFINITE UNITS
37	WS-53762	TOP W/WELLSLOK MOD200	1	M200
	P2-300714	TOP ASSY MOD227		MOD227
NI	2C-30397	CLIP ELEM WRMRS SML	18	VARIOUS OLDER UNITS
NI	2E-200372	CORD SET, 12/3 CORD 6-20	1	M200C

M011C.02 2M-Z16298 Owners Manual for Built-In Well Modular Warmers

PARTS LIST: M300-327 SERIES

Model: Modular Warmers M300-327T, TD, TDM, TDMAF, TN, M300-327E, CE, ED, EDM, EDMAF, EN

Fig No	Part No	Description	Qty	Application
1	P2-31869	SCREEN DRAIN ASSY WARMER	3	DRAIN UNITS
2	P2-Z14636	PAN ASSY 12X20 EAF W/TEE	1	M300 DIGITAL
	P2-Z14647	PAN ASSY 12X27 EAF		M327 DIGITAL
	P2-WL0066	PAN ASSY MODTDMNAF W/ELBOW		M300 T-STAT NARROW
	WS-503893	PAN ASSY 200-500TDM A/F		M300 T-STAT & INFINITE
	WS-504101	PAN ASSY 12X27 AF		M327 T-STAT
3	P2-Z14639	PAN ASSY 12X20 E	3	M300 DIGITAL
	P2-Z14637	PAN ASSY 12X20 ED w/DRAIN		M300 DIGITAL DRAIN
	P2-Z14638	PAN ASSY 12X20 EDM		M300 DIGITAL DRAIN, MANIFOLD
	P2-Z14646	PAN ASSY 12X27 EDM	2	M327 DIGITAL, DRAIN, MANIFOLD
	P2-WL0064	PAN ASSY W/ELBOW MODTDMN	2	M327 DIGITAL, AUTOFILL
	P2-WL0065	PAN ASSY MID MOD300TDMN	2	M300 T-STAT, NARROW, AUTOFILL
	WS-55741	PAN W/O DRAIN 200-500 / T	1	M300 T-STAT & NARROW
	WS-53201	PAN W/DRAIN 200-500 /TD	3	M300 T-STAT, NARROW, 2-ELBOWS
	WS-55742	PAN W/DRAIN 200-500DM/TDM	3	M300 T-STAT & INFINITE
	P2-WL0263	PAN ASSY MOD W/T DRN PASSIVATED	3	M300 T-STAT & INFINITE, DRAIN
	D8-301955	PAN ASSY SMPT-27 / MOD		M300 T-STAT & INFINITE, DRAIN, MANIFOLD
	P2-WL0061	PAN ASSY w/DRAIN M127TD		M300 T-STAT DRAIN, AUTOFILL
	WS-500700	PAN ASSY 12X27 TDM		MOD300TDMTHP
4	2V-35609	VALVE 1 IN GATE BRONZE	1	M327 T-STAT
5	WS-503713	PROBE ASSY, SS AUTOFILL WRMR	1	M327 T-STAT, DRAIN
6	2K-48198	ELBOW 3/8 X 90DEG BRASS	1	M327 T-STAT, DRAIN, MANIFOLD
7	2K-48197	NIPPLE 3/8 NPT X 2 BRASS	1	MANIFOLD UNITS
8	2V-47650	VALVE ANTISYPHON 3/8	1	AUTOFILL UNITS
9	2K-47662	FTG STR BRS 3/8NPT X3/8IN	1	AUTOFILL UNITS
10	2C-46591	CLAMP HOSE 5/8	2	AUTOFILL UNITS
11	2K-31040	BUSHING 7/8 OD	1	THERMOSTAT UNITS
12	WS-50131	TERM BLOCK KIT (RETRO 30131)	1	INFINITE & AUTOFILL UNITS
13	2C-41974	NUT 8-32 HEX 7/8 LONG ALU	2	AUTOFILL UNITS
14	2J-30385	LIGHT SIGNAL GLO DOT RED	3	INFINITE UNITS
	2J-35687	LIGHT SIGNAL GLO DOT		T-STAT UNITS
15	P2-Z12592	PANEL, CONTROL	1	INFINITE UNITS NON-AF
	P2-Z12586	PANEL, CONTROL MOD300TDM		T-STAT UNITS
15	P2-Z12588	PANEL, CONTROL MOD600 TDM	1	M300/327 T-STAT, DRAIN, MANIFOLD
16	P2-46685	BOX OUTLET MOD300, 400, 500	1	T-STAT & INFINITE UNITS NON-AF
16	P2-48178	BOX OUTLET MOD600TDM		AUTOFILL UNITS
17	2T-38968	THERMO K TYPE	3	T-STAT UNITS
	2T-46551	THERMO CTRL 96IN CAP		T-STAT UNITS w/ 96IN CAPILLARY
	2T-45917	THERMO CTRL W/AUX WARMERS		T-STAT UNITS, AUTOFILL
	2E-30570	SWITCH INFINITE, 120V	3	INFINITE UNITS, 120V
	2E-30562	SWITCH INFINITE, 240V		INFINITE UNITS, 240V
18	2R-44373	KNOB CONTROL ASSY WARMERS	3	INFINITE UNITS
	2R-40498	KNOB ASSY MOD 100DT		T-STAT UNITS
19	P2-46587	HOSE MOD AUTOFILL 36"	1	AUTOFILL UNITS

PARTS LIST: M300-327 SERIES

Model: Modular Warmers M300-327T, TD, TDM, TDMAF, TN, M300-327E, CE, ED, EDM, EDMAF, EN

Fig No	Part No	Description	Qty	Application
20	2E-46529	SOLENOID VALVE 1/4NPT 240	1	AUTOFILL UNITS
21	P2-37809	BRKT CONT MTG MOD 300 400	1	INFINITE UNITS
	P2-48586	BRKT THERMO MOD300T		T-STAT
	P2-47863	BRKT THERMO MOD BMW ROHS		T-STAT AUTOFILL
22	2E-306865	CONTROL LIQ LEVEL 208/240	1	AUTOFILL UNITS
23	2I-40034	GROMMET SCREW T4	4	AUTOFILL UNITS
24	2K-33996X	FTG FLEX CONDUIT 90X3/8	2	
25	2I-Z12311	GASKET-FIBER WASHER	2	
26	P2-300702	COVER BOT M327/ 527TDM/A	1	M327
	P2-307110	COVER BOTTOM 300 SERIES		M300
27	P2-303359	SHROUD SIDE MOD ROHS	2	M300
	P2-300593	SHROUD SIDE MOD TDN	2	M300 NARROW
28	P2-303357	SHROUD FRONT MOD300, 327T	1	M300, 327
	P2-48193	SHROUD REAR MOD 300 ROHS	1	M300, 327
	P2-307128	SHROUD FT/RR MOD300TDMN	2	M300 NARROW
29	2H-36050	INSUL FG .6 MICRO 1/36	sold by foot	
30	2H-36196	INSUL FG .6 MICRO 1X45	sold by foot	
31	P2-WL0082	PAN ELEM ASSY	3	M300 DIGITAL
	P2-WL0096	PAN ELEM ASSY MOD 227-527		M327 DIGITAL
	WS-503843	KIT PAN ELEM W/ELEMENT 208/240		M300 T-STAT
	WS-503701	KIT ELEM PAN W/ELEMENT	2	M300 T-STAT NARROW
	P2-WL0072	PAN ELEM ASSY MID MOD300T	1	
	WS-503840	KIT ELEM PAN W/ELEMENT	3	M327 T-STAT
32	WS-50396	ELEM 120V 1200W	3	M300 INFINITE, 120V
	WS-50398	ELEM 240V 1200W M P		M300 INFINITE, 240V, M300EAFTH, MOD300TDMTH, MOD300TDMTHP
	2N-46681UL	ELEM 120V 1650W		M300 T-STAT, 120V
	2N-303375UL	ELEM HEATING 240V 1650W		M300 T-STAT & DIGITAL, 240V,
	2N-300706UL	ELEM 240V 1650W 12 X 27		M327
33	WS-55707	COVER ELEM MOD WARMER	3	INFINITE UNITS
	WS-503842	KIT ELEM PAN W/O ELEMENT		M300, T-STAT & DIGITAL
	WS-WL0332	KIT ELEM PAN W/O ELEMENT / INSIDE	2	M300, NARROW, OUTSIDE
	WS-503370	PAN, ELEMENT MODS	2	M300 NARROW
	67-307041	ASSY-MID-ELEM PAN M300TN	1	
	WS-503841	KIT ELEM PAN W/O ELEMENT	3	M327
34	D8-303352	BRKT THERMO BULB	3	THERMOSTAT UNITS
35	P2-WL0081	PAN ELEM ASSY MOD200-500	3	INFINITE 208/240V
36	WS-50374	THERMO, HI-LIMIT, SFTY, 550F	3	INFINITE UNITS
37	WS-53070	TOP W/WELLSLOK	1	M300
	P2-300699	TOP ASSY M327		M327
NI	2C-30397	CLIP ELEM WRMRS SML	18	VARIOUS OLDER UNITS

PARTS LIST: M400-427 SERIES

Model: Modular Warmers M400-427T, TD, TDM, TDMAF, M400-427E, CE, ED, EDM, EDMAF

Fig No	Part No	Description	Qty	Application
1	P2-31869	SCREEN DRAIN ASSY WARMER	4	DRAIN UNITS
2	P2-Z14636	PAN ASSY 12X20 EAF W/TEE	1	M400 DIGITAL
	P2-Z14647	PAN ASSY 12X27 EAF		M427 DIGITAL
	WS-503893	PAN ASSY 200-500TDM A/F		M400 T-STAT & INFINITE
	WS-504101	PAN ASSY 12X27 AF		M427 T-STAT
3	P2-Z14639	PAN ASSY 12X20 E	4	M400 DIGITAL
	P2-Z14637	PAN ASSY 12X20 ED w/DRAIN		M400 DIGITAL DRAIN
	P2-Z14638	PAN ASSY 12X20 EDM		M400 DIGITAL DRAIN, MANIFOLD
	P2-Z14646	PAN ASSY 12X27 EDM	4	M427 DIGITAL, DRAIN, MANIFOLD
	WS-55741	PAN W/O DRAIN 200-500 / T	4	M400 T-STAT & INFINITE
	WS-53201	PAN W/DRAIN 200-500 /TD		M400 T-STAT & INFINITE, DRAIN
	WS-55742	PAN W/DRAIN 200-500DM/TDM		M400 T-STAT & INFINITE, DRAIN, MANIFOLD
	WS-500700	PAN ASSY 12X27 TDM		M400 T-STAT & INFINITE, DRAIN, MANIFOLD, AF
			3	M427 T-STAT, DRAIN, MANIFOLD, AUTOFILL
			3	M427 T-STAT, DRAIN, MANIFOLD, AUTOFILL
4	2V-35609	VALVE 1 IN GATE BRONZE	1	MANIFOLD UNITS
5	WS-503713	PROBE ASSY, SS AUTOFILL WRMR	1	AUTOFILL UNITS
6	2K-48198	ELBOW 3/8 X 90DEG BRASS	1	AUTOFILL UNITS
7	2K-48197	NIPPLE 3/8 NPT X 2 BRASS	1	AUTOFILL UNITS
8	2V-47650	VALVE ANTISYPHON 3/8	1	AUTOFILL UNITS
9	2K-47662	FTG STR BRS 3/8NPT X3/8IN	1	AUTOFILL UNITS
10	2C-46591	CLAMP HOSE 5/8	2	AUTOFILL UNITS
11	2K-31040	BUSHING HEYCO 7/8 OD	1	THERMOSTAT UNITS
12	WS-50131	TERM BLOCK KIT (RETRO 30131)	1	INFINITE & AUTOFILL UNITS
13	2C-41974	NUT 8-32 HEX 7/8 LONG ALU	2	AUTOFILL UNITS
14	2J-30385	LIGHT SIGNAL GLO DOT RED	2	INFINITE UNITS
	2J-35687	LIGHT SIGNAL GLO DOT		T-STAT UNITS
15	P2-Z12288	PANEL, CONTROL, (SPLIT)	1	MOD400TDAF6, MOD400TDMAF, MOD400TDMAF6, MOD427TDMAF
	P2-Z12589	PANEL, CONTROL, (SPLIT)		
	P2-Z12591	PANEL, CONTROL MOD 400	1	INFINITE UNITS NON-AF
	P2-Z12584	PANEL, CONTROL MOD400TDM		M400-427, T-STAT, DRAIN, MANIFOLD, AUTOFILL
16	P2-48290	BOX OUTLET MOD400 DM TDM	1	M400-427, T-STAT, DRAIN, MANIFOLD
	E7-49046	BOX OUTLET MOD (SPLIT)		MOD400TDMAF, MOD400TDMAF6, MOD427TDMAF
	P2-48175	BOX OUTLET MOD (SPLIT)		
	P2-46685	BOX OUTLET MOD 400		M400 INFINITE, DRAIN, MANIFOLD
	P2-48178	BOX, CONTROL AF		MOD400TDMAF1, MOD400TDMASF, MOD427TDMAF1
17	2T-38968	THERMO K TYPE	4	T-STAT UNITS
	2T-46551	THERMO CTRL 96IN CAP		T-STAT UNITS w/ 96IN CAPILLARY
	2T-45917	THERMO CTRL W/AUX WARMERS		T-STAT UNITS, AUTOFILL
	2T-46551	THERMO CTRL 96IN CAP		T-STAT UNITS, AUTOFILL 96IN CAPILLARY
	2E-30570	SWITCH INFINITE, 120V	4	INFINITE UNITS, 120V
	2E-30562	SWITCH INFINITE, 240V		INFINITE UNITS, 240V
18	2R-44373	KNOB CONTROL ASSY WARMERS	4	INFINITE UNITS
	2R-40498	KNOB ASSY MOD 100DT		T-STAT UNITS
20	2E-46529	SOLENOID VALVE 1/4NPT 240	1	AUTOFILL UNITS

PARTS LIST: M400-427 SERIES

Model: Modular Warmers M400-427T, TD, TDM, TDMAF, M400-427E, CE, ED, EDM, EDMAF				
Fig No	Part No	Description	Qty	Application
21	P2-40843	BRKT MTG THERMO INFINITE	2	T-STAT (SPLIT CONTROL)
	P2-48176	BRKT THERMO MOD200TDM AUT	1	MOD400TDMAF(6), MOD427TDMAF
	P2-48285	BRKT THERMO MOD400	1	M400-427 T-STAT, DRAIN, MANIFOLD, AUTOFILL
22	2E-306865	CONTROL LIQ LEVEL 208/240	1	AUTOFILL UNITS
23	2I-40034	GROMMET SCREW T4	4	AUTOFILL UNITS
24	2K-33996X	FTG FLEX CONDUIT 90X3/8	2	
25	2I-Z12311	GASKET-FIBER WASHER	2	
26	P2-300712	COVER BOT M227-427TDM/AM	2	M427E, MOD427TDM (AF)
	P2-35004	COVER BOTTOM 200 SERIES	2	M400
27	P2-303359	SHROUD SIDE MODS ROHS	2	M400
28	P2-Z14627	SHROUD, FRONT M4	1	M400, 427, DIGITAL
	P2-48192	SHROUD REAR MOD 420 427		M400
	P2-303358	SHROUD FRONT MOD 400 427		M400 INFINITE & T-STAT
29	2H-36050	INSUL FG .6 MICRO 1/36	SOLD BY FOOT	
30	2H-36196	INSUL FG .6 MICRO 1X45	SOLD BY FOOT	
31	P2-WL0082	PAN ELEM ASSY	4	M400 DIGITAL
	P2-WL0096	PAN ELEM ASSY MOD 227-527		M427 DIGITAL
	WS-503843	KIT PAN ELEM W/ELEMENT 208/240		M400 T-STAT
	WS-503840	KIT ELEM PAN W/ELEMENT		M427 T-STAT
32	WS-50398	ELEM 240V 1200W M P	4	M400 INFINITE, 240V
	2N-303375UL	ELEM HEATING 240V 1650W		M400 T-STAT, 240V
	2N-300706UL	ELEM 240V 1650W 12 X 27		M427
33	WS-55707	COVER ELEM MOD WARMER	4	M400, INFINITE UNITS
	WS-503842	KIT ELEM PAN W/O ELEMENT		M400, T-STAT & DIGITAL
	WS-503841			M427
34	D8-303352	BRKT THERMO BULB	4	THERMOSTAT UNITS
35	P2-WL0081	PAN ELEM ASSY MOD200-500	4	INFINITE 208/240V
36	WS-50374	THERMO, HI-LIMIT, SFTY, 550F	4	INFINITE UNITS
37	WS-53087	TOP DRWN W/WELLSLOK M400	1	M400
	P2-300722	TOP ASSY M427		M427
NI	2C-30397	CLIP ELEM WRMRS SML	36	VARIOUS OLDER UNITS

PARTS LIST: M500-527 SERIES

Model: Modular Warmers M500-527T, TD, TDM, TDMAF, M500-527E, CE, ED, EDM, EDMAF

Fig No	Part No	Description	Qty	Application
1	P2-31869	SCREEN DRAIN ASSY WARMER	5	DRAIN UNITS
2	P2-Z14636	PAN ASSY 12X20 EAF W/TEE	1	M500 DIGITAL
	P2-Z14647	PAN ASSY 12X27 EAF		M527 DIGITAL
	WS-503893	PAN ASSY 200-500TDM A/F		M500 T-STAT & INFINITE
	WS-504101	PAN ASSY 12X27 AF		M527 T-STAT
3	P2-Z14639	PAN ASSY 12X20 E	5	M500 DIGITAL
	P2-Z14637	PAN ASSY 12X20 ED w/DRAIN		M500 DIGITAL DRAIN
	P2-Z14638	PAN ASSY 12X20 EDM		M500 DIGITAL DRAIN, MANIFOLD
	P2-Z14646	PAN ASSY 12X27 EDM	5	M527 DIGITAL, DRAIN, MANIFOLD
	WS-55741	PAN W/O DRAIN 200-500 / T	5	M527 DIGITAL, DRAIN, MANIFOLD AUTOFILL
	WS-53201	PAN W/DRAIN 200-500 /TD		M500 T-STAT & INFINITE
	WS-55742	PAN W/DRAIN 200-500DM/TDM		M500 T-STAT & INFINITE, DRAIN
	WS-500700	PAN ASSY 12X27 TDM		M500 T-STAT & INFINITE, DRAIN, MANIFOLD, AUTOFILL
			4	M527 T-STAT, DRAIN, MANIFOLD, AUTOFILL
	4	2V-35609	VALVE 1 IN GATE BRONZE	1
5	WS-503713	PROBE ASSY, SS AUTOFILL WRMR	1	AUTOFILL UNITS
6	2K-48198	ELBOW 3/8 X 90DEG BRASS	1	AUTOFILL UNITS
7	2K-48197	NIPPLE 3/8 NPT X 2 BRASS	1	AUTOFILL UNITS
8	2V-47650	VALVE ANTISYPHON 3/8	1	AUTOFILL UNITS
9	2K-47662	FTG STR BRS 3/8NPT X3/8IN	1	AUTOFILL UNITS
10	2C-46591	CLAMP HOSE 5/8	2	AUTOFILL UNITS
11	2K-31040	BUSHING HEYCO 7/8 OD	1	THERMOSTAT UNITS
12	WS-50131	TERM BLOCK KIT (RETRO 30131)	1	INFINITE & AUTOFILL UNITS
13	2C-41974	NUT 8-32 HEX 7/8 LONG ALU	2	AUTOFILL UNITS
14	2J-30385	LIGHT SIGNAL GLO DOT RED	2	INFINITE UNITS
	2J-35687	LIGHT SIGNAL GLO DOT		T-STAT UNITS
15	P2-Z12594	PANEL, CONTROL MOD500 TDM	1	M500-527, T-STAT
	P2-Z12288	PNL, CNTRL/MOD		MOD500TDMFA(6), MOD527TDMFA(6) (SPLTI)
	P2-Z12588	PANEL, CONTROL MOD TDM		MOD500TDMFA(6), MOD527TDMFA(6) (SPLTI)
	P2-Z12590	PANEL, CONTROL MOD500		M500, INFINITE UNITS
16	P2-48290	BOX OUTLET MOD400 DM TDM	1	M500-527, T-STAT
	E7-49046	BOX OUTLET MOD WAR		MOD500TDMFA(6), MOD527TDMFA(6) (SPLTI)
	P2-48178	BOX CONTROL MOD AF		MOD500TDMFA(6), MOD527TDMFA(6) (SPLTI)
	P2-46685	BOX OUTLET MOD 500		M500, INFINITE UNITS
17	2T-38968	THERMO K TYPE	5	T-STAT UNITS
	2T-46551	THERMO CTRL 96IN CAP		T-STAT UNITS w/ 96IN CAPILLARY
	2T-45917	THERMO CTRL W/AUX WARMERS		T-STAT UNITS, AUTOFILL
	2E-30570	SWITCH INFINITE, 120V	5	INFINITE UNITS, 120V
	2E-30562	SWITCH INFINITE, 240V		INFINITE UNITS, 240V
18	2R-44373	KNOB CONTROL ASSY WARMERS	5	INFINITE UNITS
	2R-40498	KNOB ASSY MOD 100DT		T-STAT UNITS
19	P2-46587	HOSE MOD AUTOFILL 36IN	1	AUTOFILL UNITS
20	2E-46529	SOLENOID VALVE 1/4NPT 240	1	AUTOFILL UNITS

PARTS LIST: M500-527 SERIES

Model: Modular Warmers M500-527T, TD, TDM, TDMAF, M500-527E, CE, ED, EDM, EDMAF

Fig No	Part No	Description	Qty	Application
21	P2-48285	BRKT THERMO MOD400	1	M500-527, T-STAT
	P2-40843	BRKT MTG THERMO INFINITE	2	MOD500TDMFA(6), MOD527TDMAF(6) (SPLTI)
	P2-47863	BRKT THERMO MOD	1	MOD500TDMFA(6), MOD527TDMAF(6) (SPLTI)
	P2-37809	BRKT CONT MTG MOD	1	M500 INFINITE
22	2E-306865	CONTROL LIQ LEVEL 208/240	1	AUTOFILL UNITS
23	2I-40034	GROMMET SCREW T4	4	AUTOFILL UNITS
24	2K-33996X	FTG FLEX CONDUIT 90X3/8	2	
25	2I-Z12311	GASKET-FIBER WASHER	2	
26	P2-35004	COVER BOTTOM 200 SERIES	1	M500
	P2-307110	COVER BOTTOM MOD300 SERIES		M527
	P2-300712	COVER BOT MOD227/427TDM/A		
	P2-300704	COVER BOT MOD327/527TDM/A		
27	P2-303359	SHROUD SIDE MODS ROHS	2	M500
28	P2-Z14627	SHROUD, FRONT M4	1	M500, 427, DIGITAL
	P2-48191	SHROUD REAR MOD 500 527		M500
	P2-303376	SHROUD FRONT MOD 500 527T		M500 INFINITE & T-STAT
29	2H-36050	INSUL FG .6 MICRO 1/36	SOLD BY FOOT	
30	2H-36196	INSUL FG .6 MICRO 1X45	SOLD BY FOOT	
31	P2-WL0082	PAN ELEM ASSY	5	M500 DIGITAL
	P2-WL0096	PAN ELEM ASSY MOD 227-527		M527 DIGITAL
	WS-503843	KIT PAN ELEM W/ELEMENT 208/240		M500 T-STAT
	WS-503840	KIT ELEM PAN W/ELEMENT		M527 T-STAT
32	WS-50398	ELEM 240V 1200W M P	5	M500 INFINITE, 240V
	2N-303375UL	ELEM HEATING 240V 1650W		M500 T-STAT, 240V
	2N-300706UL	ELEM 240V 1650W 12 X 27		M527
33	WS-55707	COVER ELEM MOD WARMER	5	M500, INFINITE UNITS
	WS-503842	KIT ELEM PAN W/O ELEMENT		M500, T-STAT & DIGITAL
	WS-503841	KIT ELEM PAN W/O ELEMENT		M527
34	D8-303352	BRKT THERMO BULB	4	THERMOSTAT UNITS
35	P2-WL0081	PAN ELEM ASSY MOD200-500	4	INFINITE 208/240V
36	WS-50374	THERMO, HI-LIMIT, SFTY, 550F	4	INFINITE UNITS
37	WS-53096	TOP W/WELLSLOK M500	1	M500
	P2-300730	TOP ASSY M527		M527
NI	2C-30397	CLIP ELEM WRMRS SML	36	VARIOUS OLDER UNITS

EXPLODED VIEW: DETAIL A

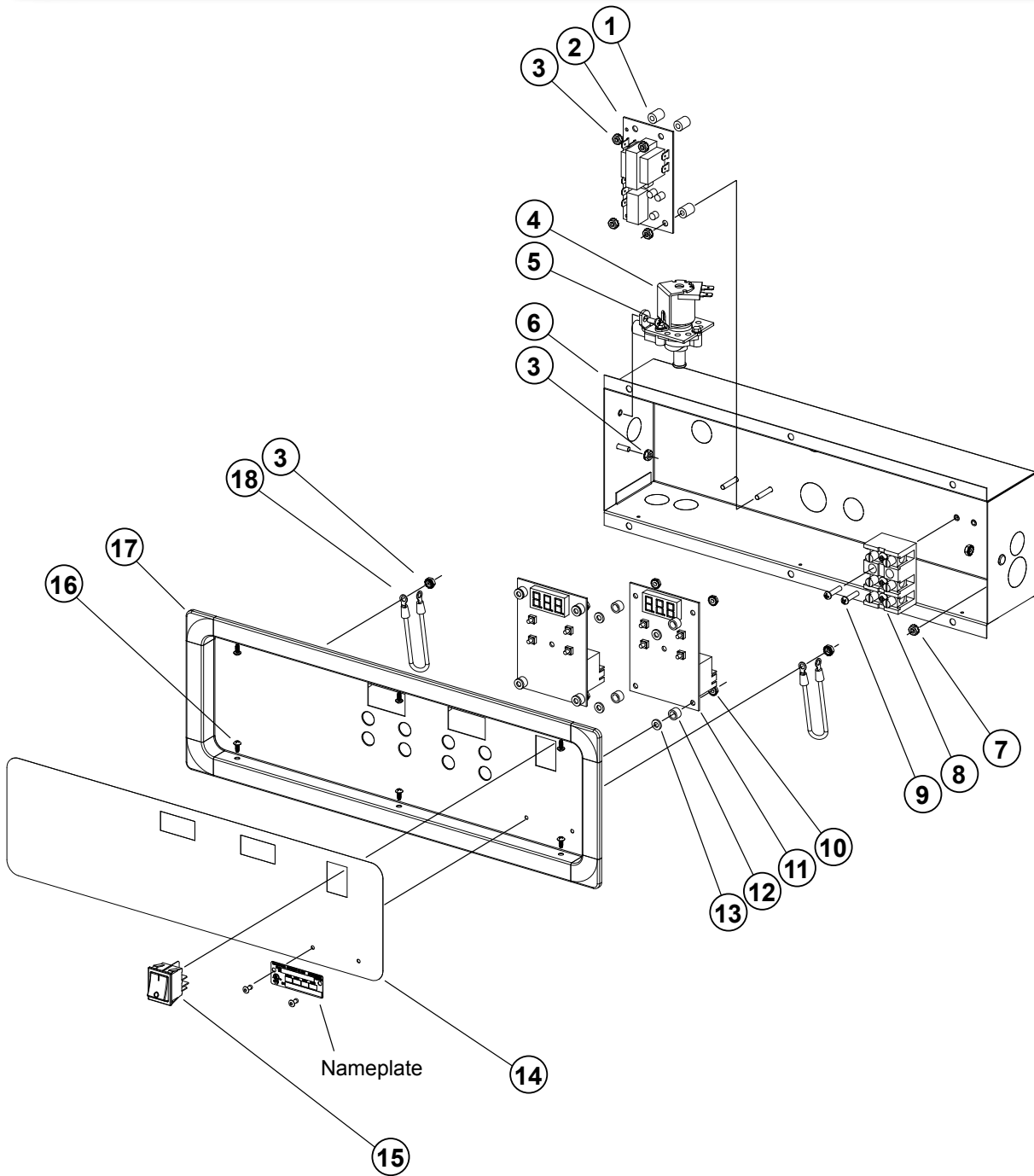

SOME ITEMS ARE A REPRESENTATION OF THE ACTUAL APPEARANCE DUE TO YOUR SPECIFIC MODEL.

Detail A

MODE - EAF
Digital Control Fab Warmer

IL2523, Rev. -, 8/21/12

PARTS LIST: DETAIL A

Detail A: Digital Control Box Assy			
Fig No	Part No	Description	Application
1	2A-Z3429	SPACER-NYLON .175X.375X.5	AUTO-FILL
2	2E-306865	CONTROL LIQ LEVEL 208/240	AUTO-FILL
3	2C-31053	NUT 8-32 KEPS MS NICKEL	
4	2E-46529	SOLENOID VALV 1/4NPT 240	AUTO-FILL
5	2C-1493	SCREW 8-32X3/8 RHP STL NP	AUTO-FILL
6	P2-Z14490	CONTROL BOX WELD - SMALL	M200-227E
	P2-Z14497	CONTROL BOX WELD - MEDIUM	M200-227EAF, M300-327E
	P2-Z14493	CONTROL BOX WELD - LARGE	M300-327EAF, M400/427E, M400/427EAF, M500/527E, M500/527EAF
7	2C-35736	NUT 8-32 HEX KEPS MS GREE	ALL
8	2E-37465	TERM BLOCK 3POLE 85AMP	ALL
9	2C-1496	SCREW 8-32X3/4 RHP STL NP	ALL
10	2C-Z2594	NUT 6-32 HEX W STL NP	ALL
11	2E-Z14534	CONTROLLER, TEMP 230V	AUTO-FILL
	2E-Z14534-1	THERMISTOR, 90"	
	2E-Z14534-2	THERMISTOR, 126"	6' LEAD
12	2K-Z1971	SPACER .257X.75X.25 NYLON	AUTO-FILL
13	2C-200110	WASHER, #8 FLAT 18-8 SS	ALL
14	2M-Z14495	GRAPHIC M200/227EAF	M200-227E
	2M-Z14498	GRAPHIC M200/227EAF	M200-227EAF
	2M-Z14499	GRAPHIC M300/327E	M300-327E
	2M-Z14526	GRAPHIC M300/327EAF	M300-327EAF
	2M-Z14527	GRAPHIC M400/427E	M400/427E, M400/427EAF
	2M-Z14529	GRAPHIC M500/527E	M500/527E, M500/527EAF
15	2E-Z1858	SWITCH-LIGHTED	AUTO-FILL
16	2C-33935	SCREW 6ABX5/16 PH PAN SMS	ALL
17	P2-Z14494	CONTROL PANEL M200/227E	M200-227E
	P2-Z14496	CONTROL PANEL M200/227EAF	M200-227EAF
	P2-Z14522	CONTROL PANEL M300/327E	M300-327E
	P2-Z14524	CONTROL PANEL M300/327EAF	M300-327EAF
	P2-Z14525	CONTROL PANEL M400/427E	M400/427E, M400/427EAF
	P2-Z14492	CONTROL PANEL M500/527E	M500/527E, M500/527EAF
18	2E-130601	WIRE ASSY 14GA GREEN 8"	ALL
NI	2K-34136X	FTG FLEX CON 90 X 1/2 MOD	AUTO-FILL

WIRING DIAGRAM: Infinite Control Units

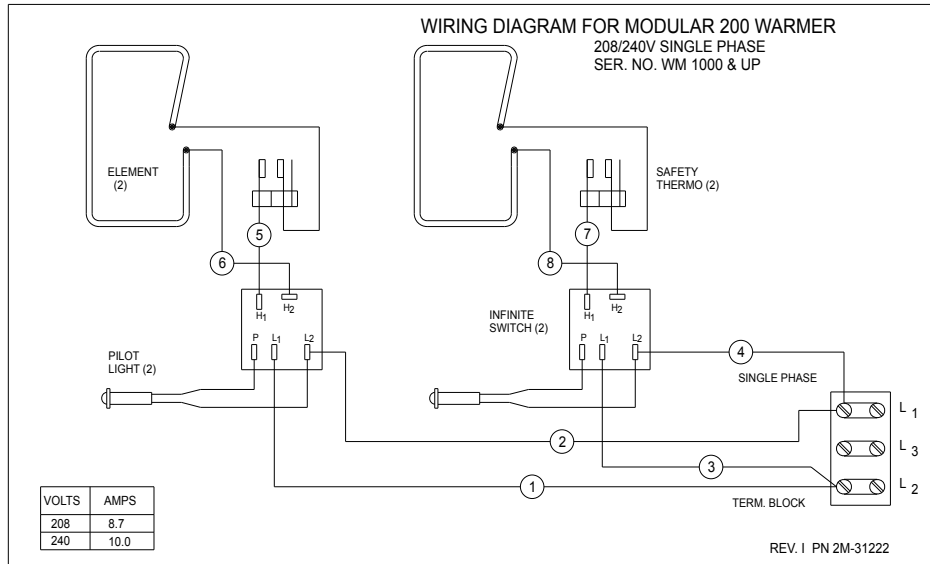

MOD200 & MOD227 Series

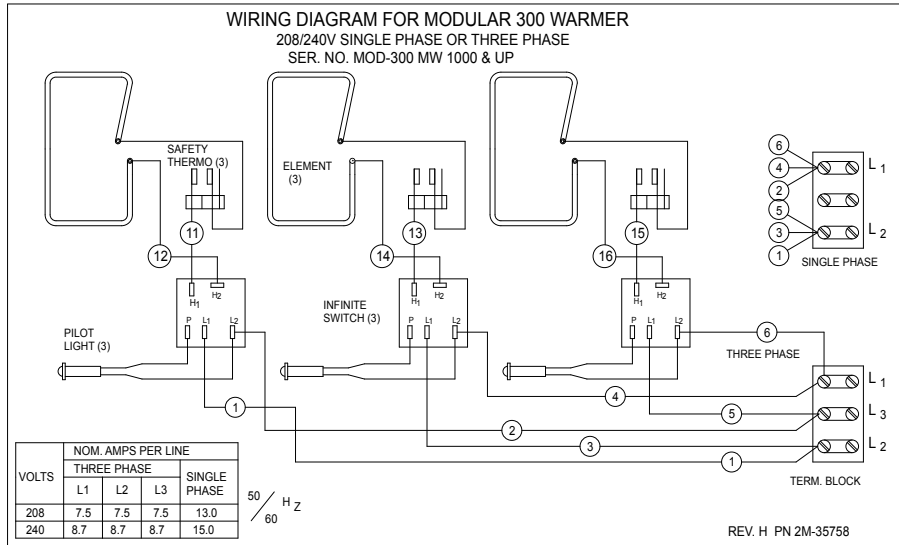

MOD300E & MOD327E Series

WIRING DIAGRAM: Infinite Control Units

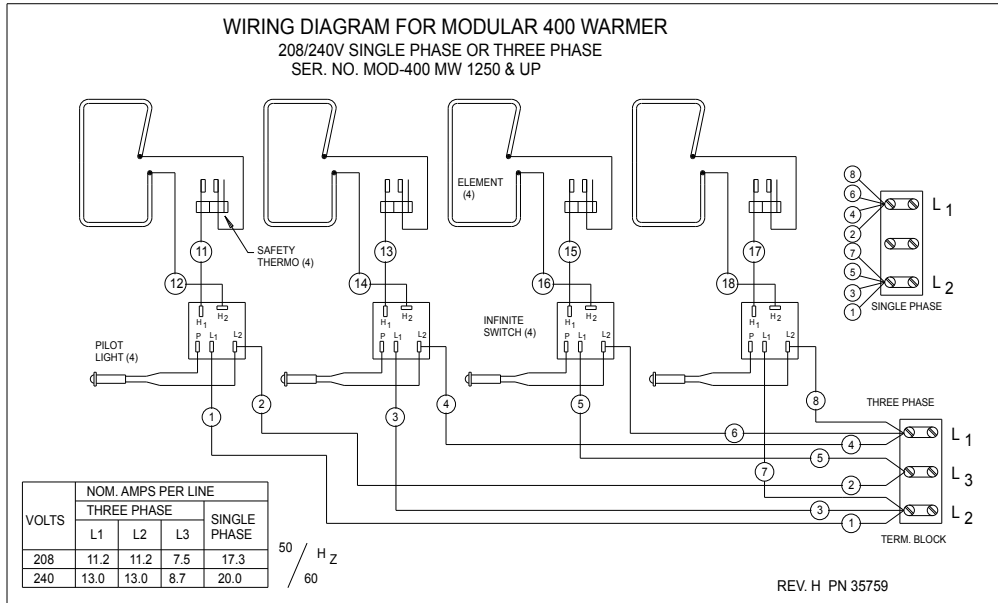

MOD400E & MOD427E Series

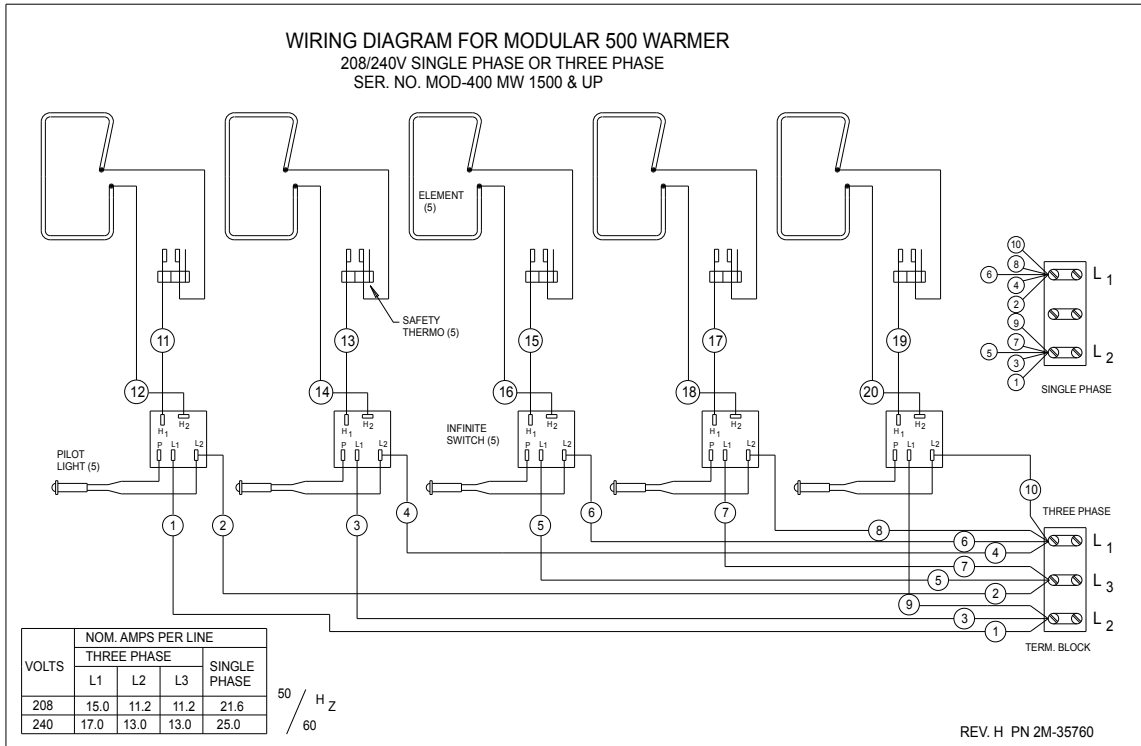

MOD500E & MOD527E Series

M011C.02 2M-Z16298 Owners Manual for Built-In Well Modular Warmers

WIRING DIAGRAM: Electronically Control Units

NOTES: WIRING DIAGRAM MOD400E

- 1) TEMPERATURE AND WATER LEVEL SENSOR WIRES ROUTE SEPARATELY IN SMALLER CONDUIT.
- 2) GROUND TO EARTH USING SUPPLIED STUD IN CONTROL BOX.
- 3) OPTIONAL WATER LEVEL CONTROL: WIRES 19 & 35 SHOULD BE CAPPED IF NOT USED.

MODEL	V	WATTS	3&	1&
MOD400E	208	4960	14.5	9.8
	240	9600	17.8	11.3
			14.5	23.8
			17.8	27.5

50/60 Hz

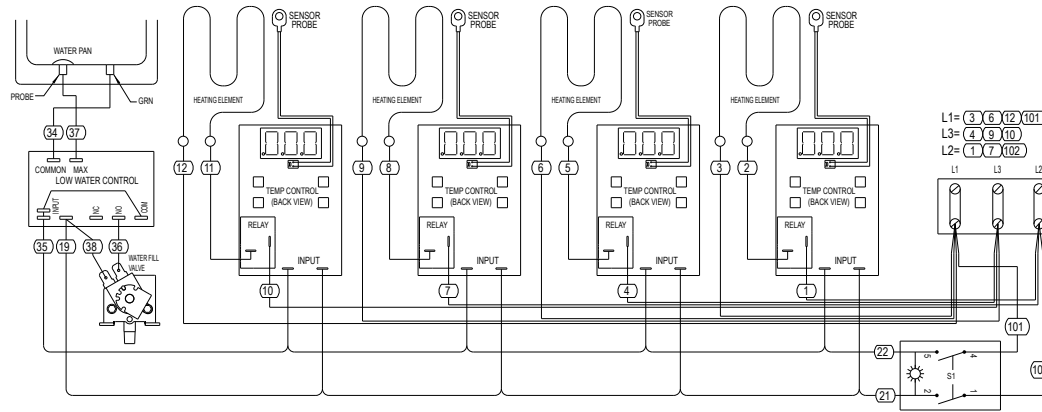
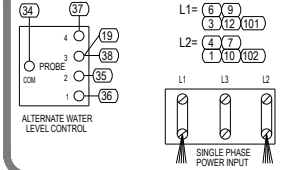

M400E & M427E Series

NOTES: WIRING DIAGRAM MOD500E

- 1) TEMPERATURE AND WATER LEVEL SENSOR WIRES ROUTE SEPARATELY IN SMALLER CONDUIT.
- 2) GROUND TO EARTH USING SUPPLIED STUD IN CONTROL BOX.
- 3) OPTIONAL WATER LEVEL CONTROL: WIRES 19 & 35 SHOULD BE CAPPED IF NOT USED.

MODEL	V	WATTS	3&	1&
MOD500E	208	6196	14.6	19.5
	240	8250	16.9	22.1
			14.6	29.8
			16.9	34.4

50/60 Hz

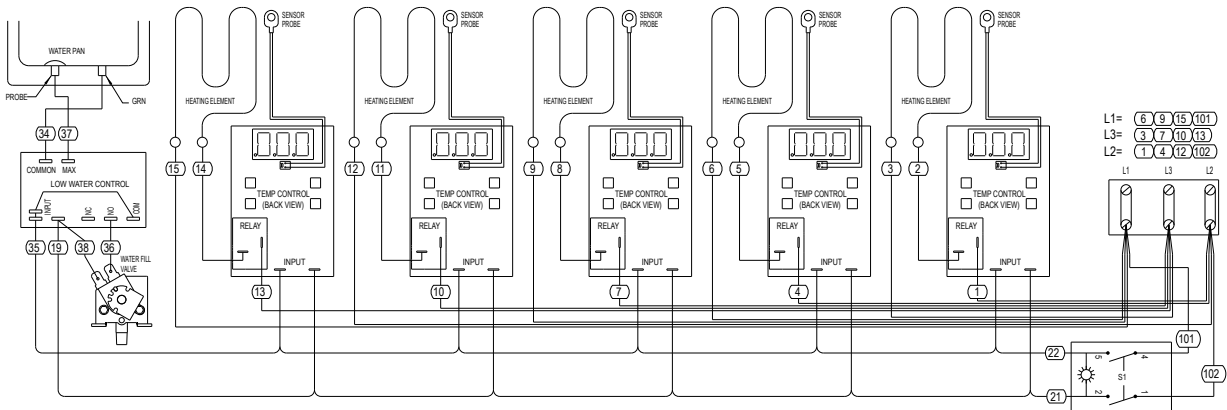
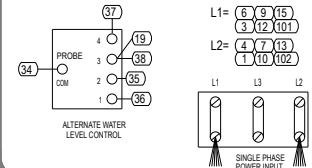

M500E & M527E Series

WIRING DIAGRAM: MOD200 Thermostat Control Units

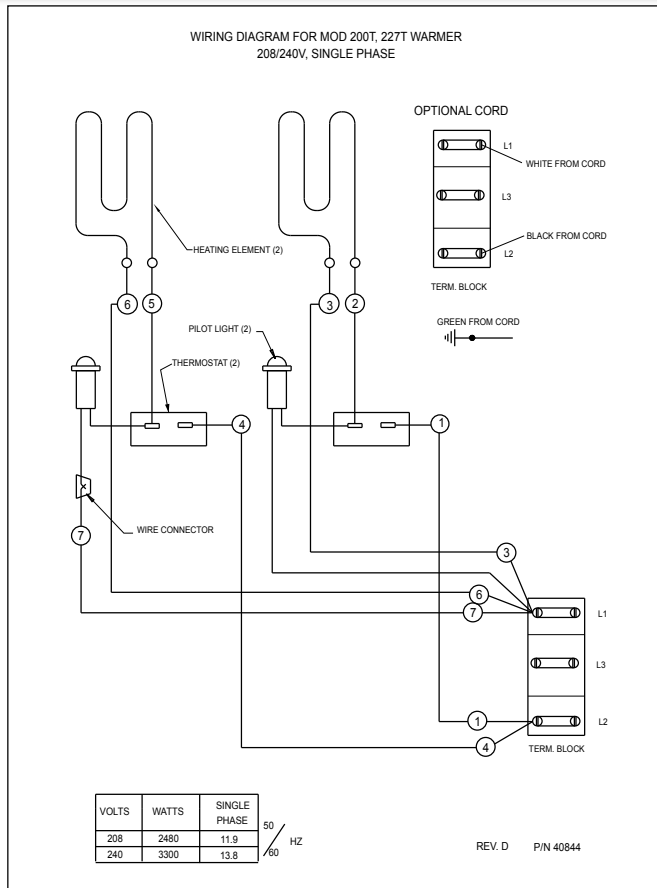

M200T & M227T Series

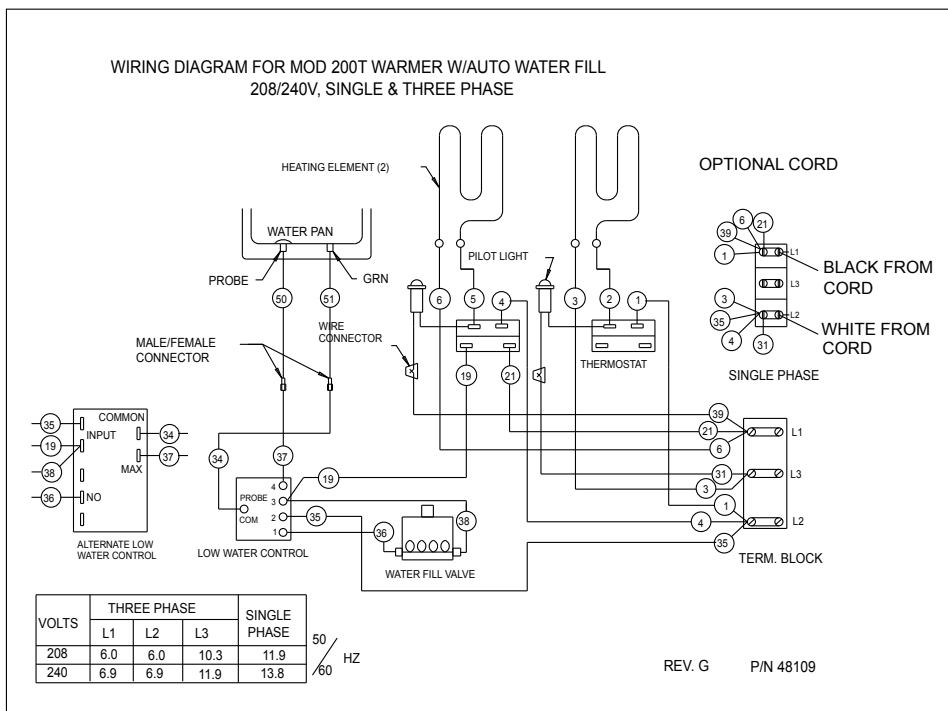

M200T-AF & M227T-AF Series

WIRING DIAGRAM: MOD300 Thermostat Control Units

WIRING DIAGRAM FOR MOD 300T, 327T WARMER
208/240V, SINGLE & THREE PHASE

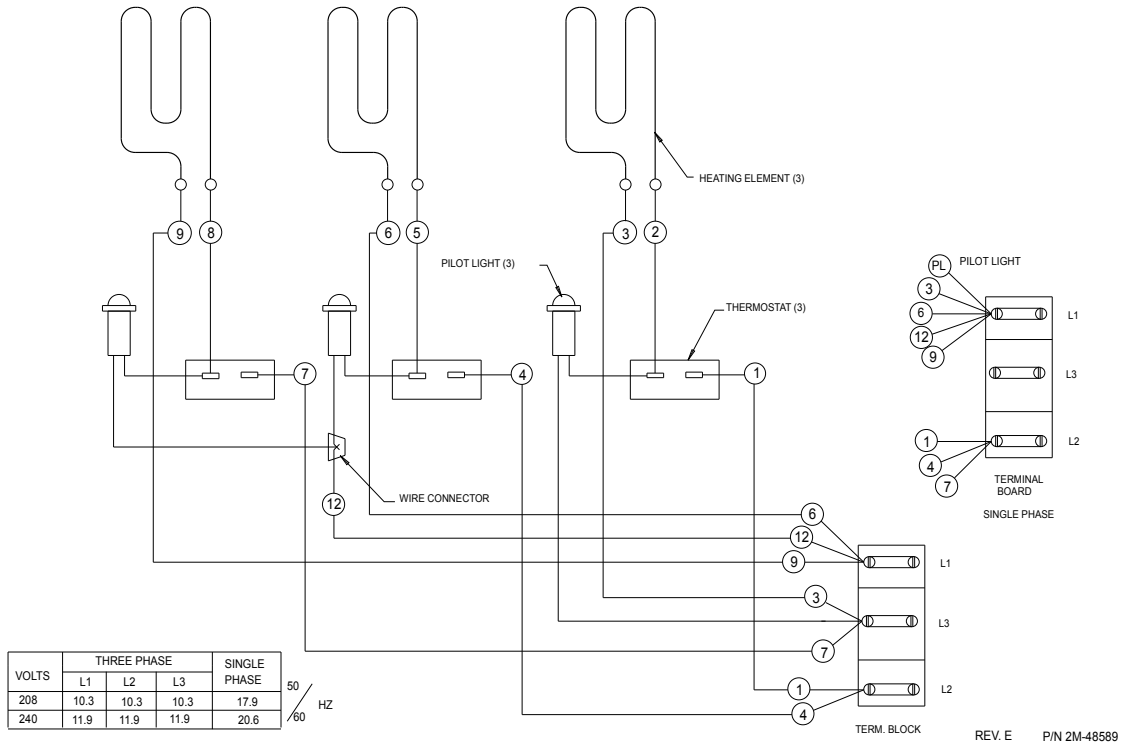

M300T & M327T Series

WIRING DIAGRAM FOR MOD300TDM AND 327TDM W/AUTO WATER FILL
208/240V, SINGLE & THREE PHASE

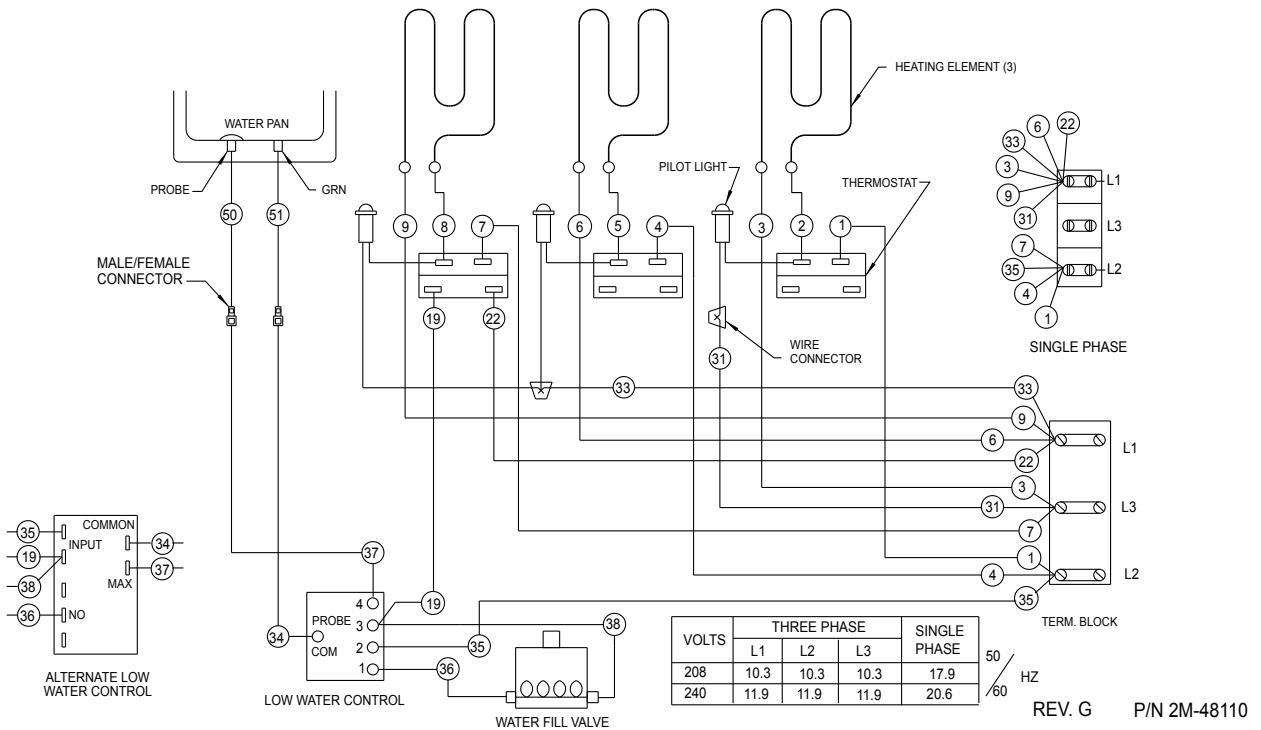

M300T-AF & M327T-AF Series

M011C.02 2M-Z16298 Owners Manual for Built-In Well Modular Warmers

WIRING DIAGRAM: MOD400 Thermostat Control Units

WIRING DIAGRAM FOR MOD 400T, 427T WARMER
208/240V, SINGLE & THREE PHASE

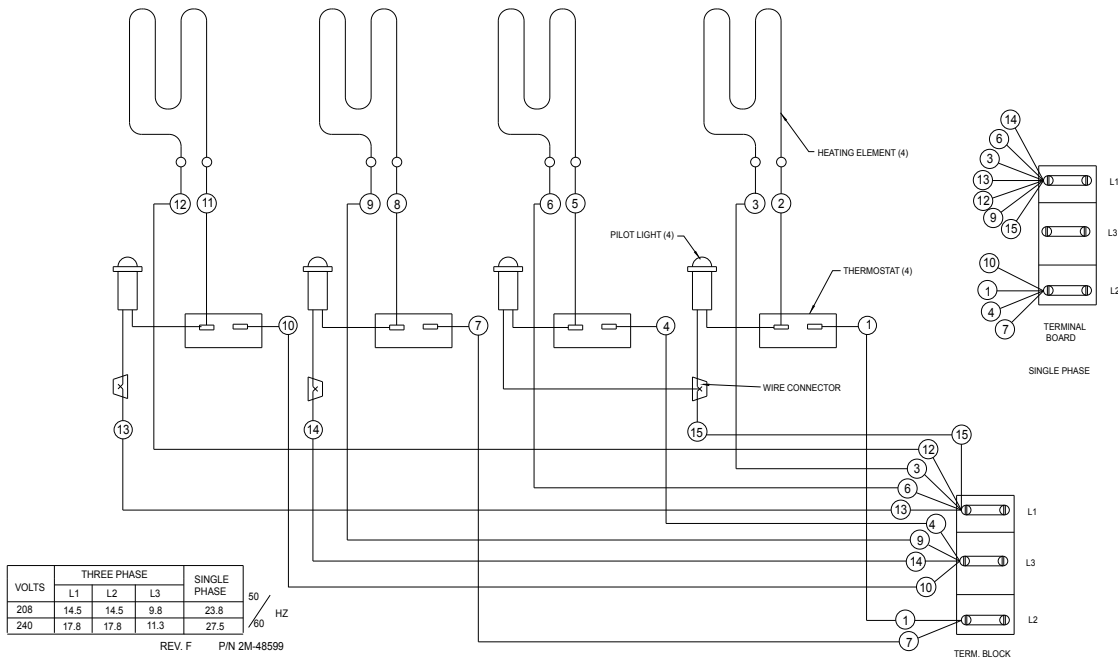

M400T & M427T Series

WIRING DIAGRAM FOR MOD-400TDM, 427TDM W/AUTO WATER FILL (SINGLE CONTROL PANEL)
208/240V, SINGLE & THREE PHASE

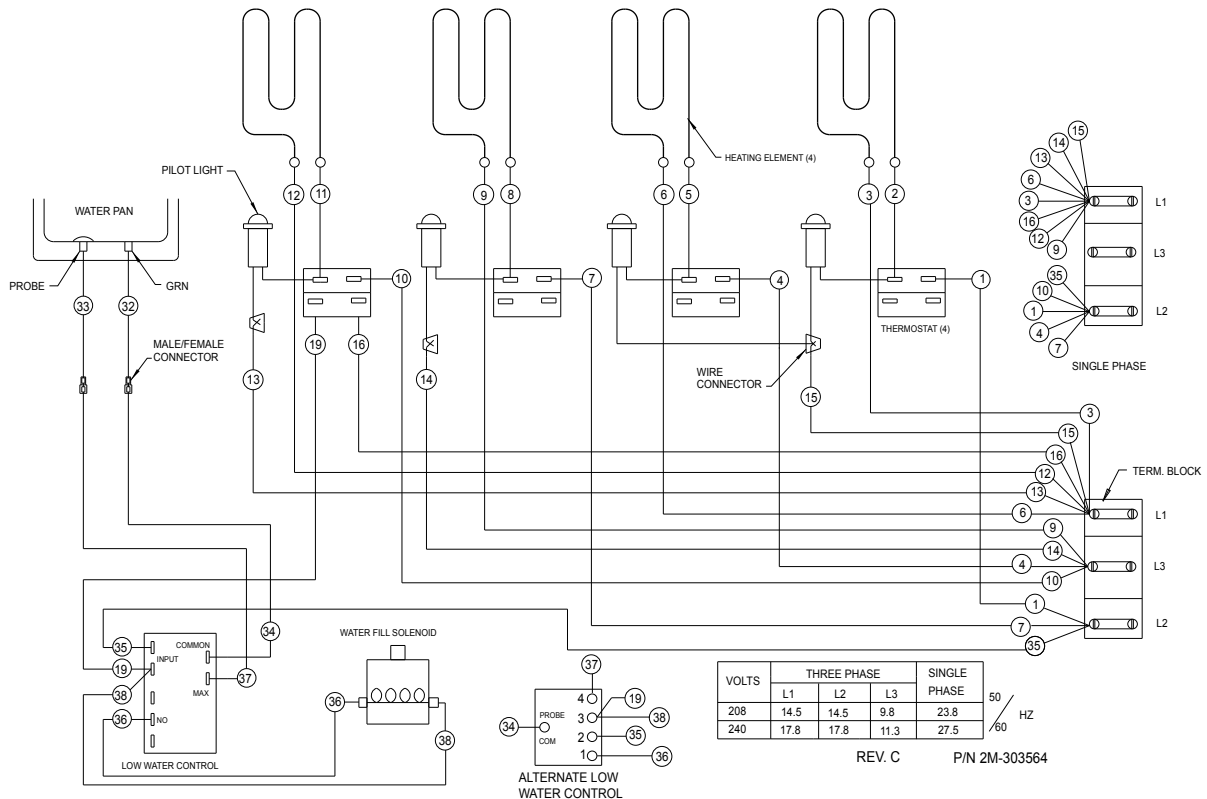

M400T-AF & M427T-AF Series (Single Control Panel)

WIRING DIAGRAM: MOD400 Thermostat Control Units

WIRING DIAGRAM FOR MOD400TDM & 427TDM WARMER W/AUTO WATER FILL
208/240V, SINGLE & THREE PHASE

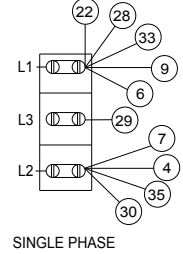
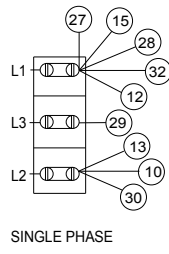
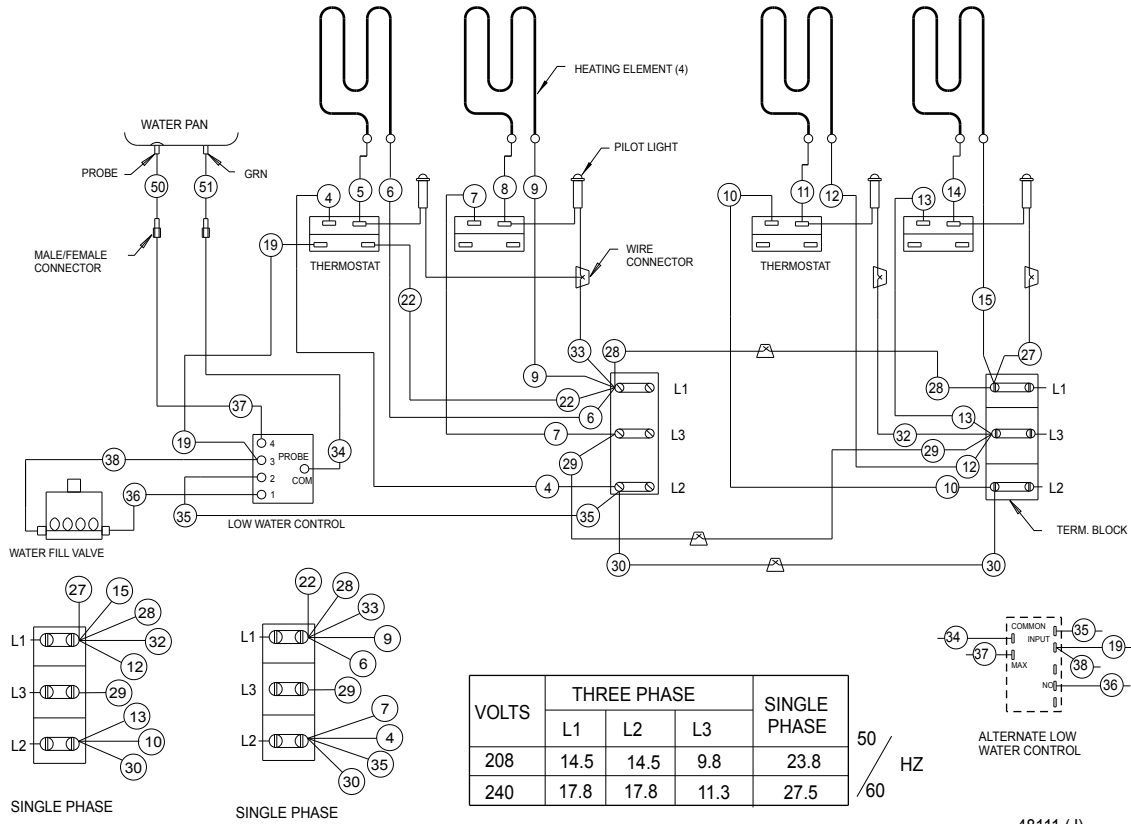

VOLTS	THREE PHASE			SINGLE PHASE	50 / 60 HZ
	L1	L2	L3		
208	14.5	14.5	9.8	23.8	
240	17.8	17.8	11.3	27.5	

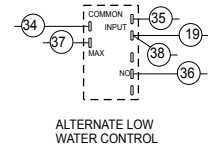

48111 (J)

M400T-AF & M427T-AT Series (Dual Control Panel)

M011C.02 2M-Z16298 Owners Manual for Built-In Well Modular Warmers

WIRING DIAGRAM: MOD500 Thermostat Control Units

WIRING DIAGRAM FOR MOD 500T, 527T WARMER
208/240V, SINGLE & THREE PHASE

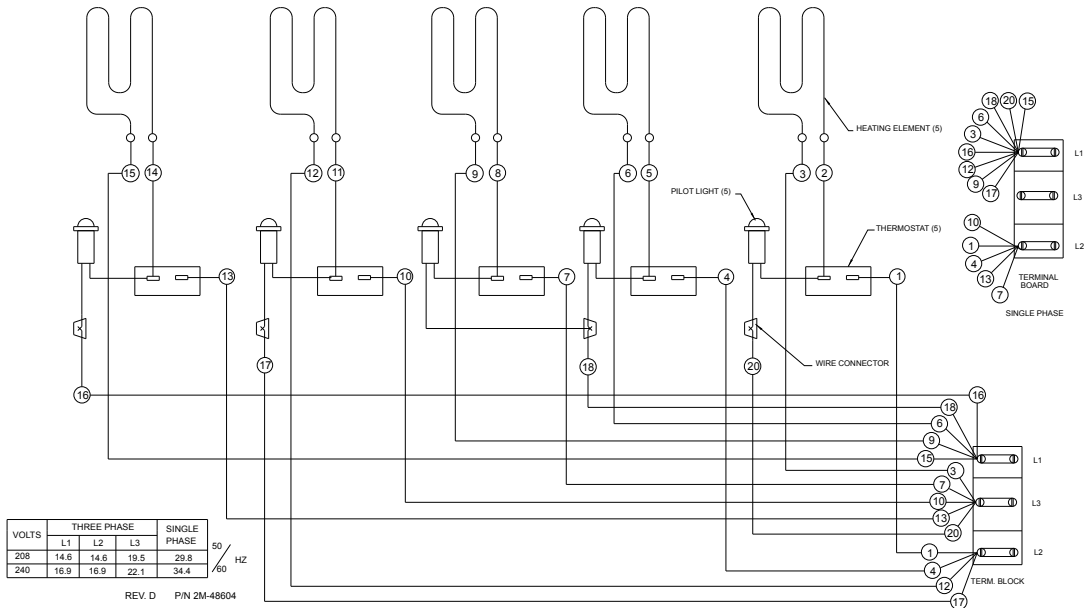

M500T & M527T Series

WIRING DIAGRAM FOR MOD-500TDM, 527TDM W/AUTO WATER FILL (SINGLE CONTROL PANEL)
208/240V, SINGLE & THREE PHASE

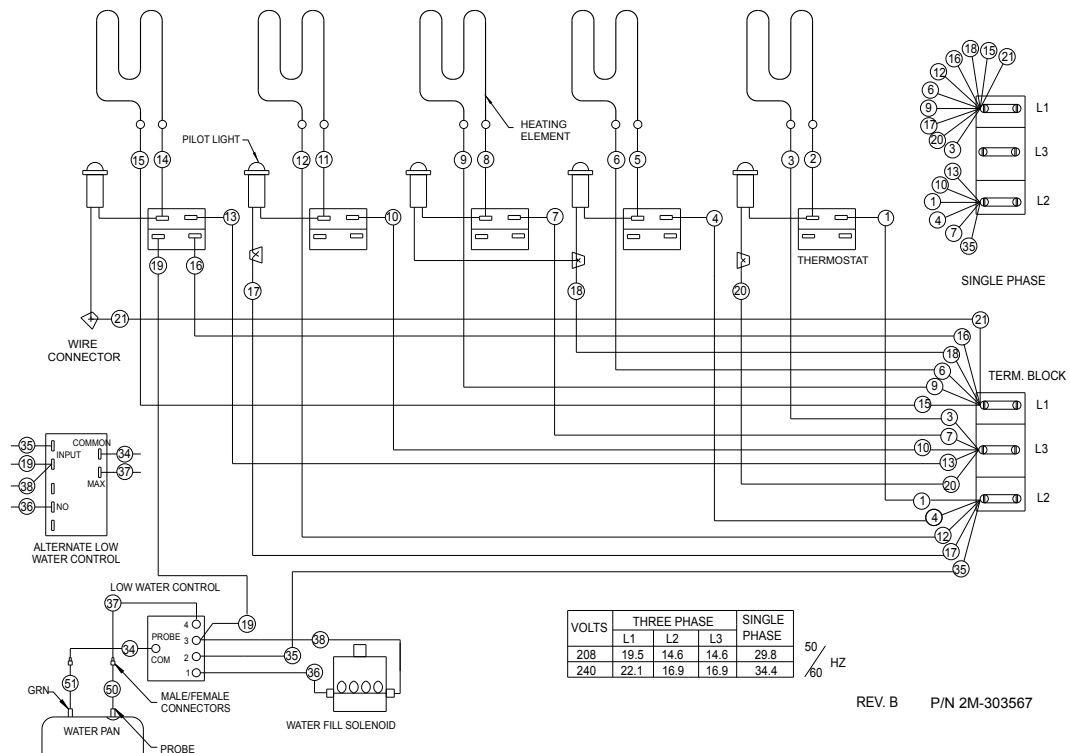

M500T-AF & M527T-AF Series (Single Control Panel)

WIRING DIAGRAM: MOD500 Thermostat Control Units

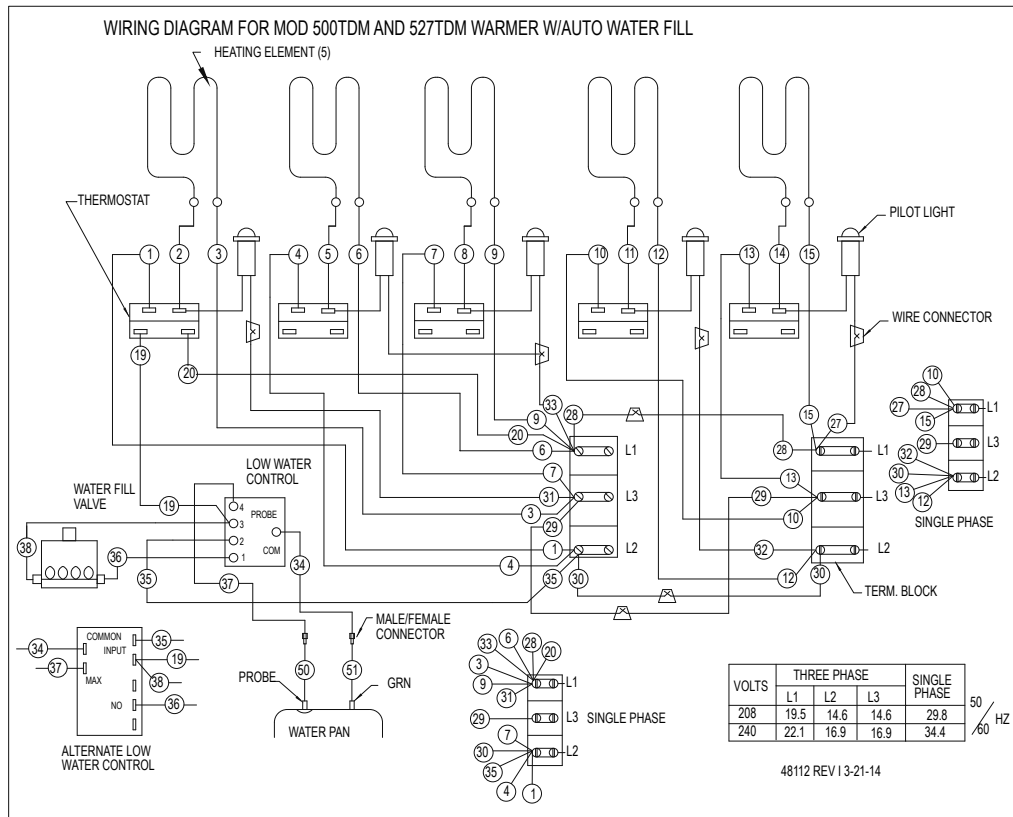

M500T-AF & M527T-AT Series (Dual Control Panel)

PARTS & SERVICE

Always use an inset.

DO NOT place food directly into the warmer pan.

DESCRIPTION

PART NO.

ADAPTERS & INSETS

ADAPTER TOP, convert 12" x 20" warmer to hold two 7 qt. insets	WS-21502
ADAPTER TOP, convert 12" x 20" warmer to hold two 4 qt. and two 2½ qt	DD-21503
ADAPTER TOP, convert 12" x 20" warmer to hold three 4 qt. insets	DD-21616
ADAPTER TOP, convert 12" x 20" warmer to hold one 7qt. and one 4 qt.	DD-21618
ADAPTER TOP, convert 12" x 20" warmer to hold four 2½ qt. insets	WS-21623
ADAPTER TOP, convert 12" x 27" SMPT-27 to hold three 7 qt. insets	DD-21503
4 QT. ROUND INSET w/ lid	WS-20774
7 QT. ROUND INSET w/ lid	WS-20587
11 QT. ROUND INSET w/ lid	WS-20908
11 QT. ROUND INSET w/ hinged lid	WS-21057

PARTS & SERVICE

DESCRIPTION ACCESSORIES

PART NO.

IMPORTANT: Use only factory authorized service parts and replacement filters.

WELLSLOK EXTENSION KIT, for UL LISTED
circular warmers only, adapt to wood counter
up to 1¾" thick

WS-22592*

For factory authorized service, or to order factory authorized replacement parts, contact your Wells authorized service agency, or call:

WELLSLOK EXTENSION KIT, for UL LISTED
12" x 20" warmers only, adapt to wood counter
up to 1¾" thick

WS-22593*

Wells Manufacturing

265 Hobson Street
Smithville, Tennessee 37166 U.S.A.

*Wellslok Extension Kits for UL Listed units approved for installation in wood counter tops

One well units require one kit / Two and three well units require two kits / four and five well units require three kits

Service Dept.

phone: (314) 678-6314
fax: (314) 781-2714

DRAIN VALVE EXTENSION KIT, extension from
drain to counter front with remote handle, for use
with "D" models only, excluding "DM" models

WS-20385

Service Parts Department can supply you with the name and telephone number of the WELLS AUTHORIZED SERVICE AGENCY nearest you.

DRAIN SCREEN

P2-31869

OPTIONAL 72" WIRING, thermostatically controlled warmers**

** contact factory customer service for availability

CUSTOMER SERVICE DATA

please have this information available if calling for service

RESTAURANT _____ LOCATION _____
 INSTALLATION DATE _____ TECHNICIAN _____
 SERVICE COMPANY _____
 ADDRESS _____ STATE _____ ZIP _____
 TELEPHONE NUMBER (____)____-_____
 EQUIPMENT MODEL NO. _____
 EQUIPMENT SERIAL NO. _____
 VOLTAGE: (check one) 120 208 240



Wells Bloomfield proudly supports CFESA
Commercial Food Equipment Service Association

SERVICE TRAINING - QUALITY SERVICE



CUSTOMER SATISFACTION



WELLS MANUFACTURING

265 Hobson Street, Smithville, Tennessee 37166

telephone: 314-678-6314

fax: 314-781-2714

www.wells-mfg.com