

WELLS BLOOMFIELD, LLC
10 Sunnen Dr., St. Louis, MO 63143
telephone: 888-356-5362
fax: 314-781-2714
www.wells-mfg.com

903

OWNERS MANUAL

**MODEL
M4200-3S
CONVECTION
OVEN**

**Includes
OPERATING
INSTRUCTIONS**

**MAINTENANCE
INSTRUCTIONS**

PARTS LIST



*Model M4200-3S
with optional PREP TOP*

IMPORTANT: DO NOT DISCARD THIS MANUAL

This manual is considered to be part of the appliance and is to be given to the OWNER or MANAGER of the restaurant, or to the person responsible for TRAINING OPERATORS of this appliance. Additional manuals are available from your WELLS DEALER.

THIS MANUAL MUST BE READ AND UNDERSTOOD BY ALL PERSONS USING OR INSTALLING THIS APPLIANCE. Contact your WELLS DEALER if you have any questions concerning installation, operation or maintenance of this equipment.

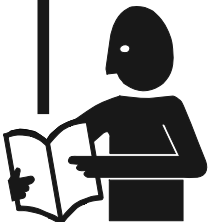

LIMITED WARRANTY STATEMENT

Unless otherwise specified, all commercial cooking equipment manufactured by WELLS MFG. CO. is warranted against defects in materials and workmanship for a period of one year from the date of original installation or 18 months from the date of shipment from our factory, whichever comes first, and is for the benefit of the original purchaser only.

THIS WARRANTY IS THE COMPLETE AND ONLY WARRANTY, EXPRESSED OR IMPLIED IN LAW OR IN FACT, INCLUDING BUT NOT LIMITED TO, WARRANTIES OF MERCHANTABILITY OR FITNESS FOR ANY PARTICULAR PURPOSE, AND/OR FOR DIRECT, INDIRECT OR CONSEQUENTIAL DAMAGES IN CONNECTION WITH WELLS MFG. CO. PRODUCTS. This warranty is void if it is determined that, upon inspection by an authorized service agency, the equipment has been modified, misused, misapplied, improperly installed, or damaged in transit or by fire, flood or act of God. It also does not apply if the serial nameplate has been removed, or if service is performed by unau-

thorized personnel. The prices charged by Wells Mfg. Co. for its products are based upon the limitations in this warranty. Seller's obligation under this warranty is limited to the repair of defects without charge by a Wells Mfg. Co. factory authorized service agency or one of its sub-service agencies. This service will be provided on customer's premises for non-portable models. Portable models (a device with a cord and plug) must be taken or shipped to the closest authorized service agency, transportation charges prepaid, for service. In addition to restrictions contained in this warranty, specific limitations are shown in the Service Policy and Procedure Guide. Wells Mfg. Co. authorized service agencies are located in principal cities. This warranty is valid in the United States and Canada and void elsewhere. Please consult your classified telephone directory, your foodservice equipment dealer or write the Factory Service Department, Wells Manufacturing Company, 10 Sunnen Dr., St. Louis, MO 63143, phone (888) 356-5362 or fax (314) 781-2714, for information and other details concerning warranty.

SERVICE POLICY AND PROCEDURE GUIDE ADDITIONAL WARRANTY EXCLUSIONS

1. Resetting of safety thermostats, circuit breakers, over load protectors, and/or fuse replacements are **not** covered by this warranty unless warranted conditions are the cause.
2. All problems due to operation at **voltages or phase other than specified on equipment nameplates** are **not** covered by this warranty. Conversion to correct voltage and/or phase must be the customer's responsibility.
3. All problems due to **electrical connections not made in accordance with electrical code requirements and wiring diagrams** supplied with the equipment are **not** covered by this warranty.
4. Replacement of items **subject to normal wear**, to include such items as knobs, light bulbs; and, normal maintenance functions including adjustments of thermostats, adjustment of micro switches and replacement of fuses and indicating lights are **not** covered by warranty.
5. Damage to electrical cords and/or plug due to exposure to excessive heat are **not** covered by this warranty.
6. Full use, care, and maintenance instructions supplied with each machine. Noted maintenance and preventative maintenance items, such as servicing and cleaning schedules, are customer responsibility. Those miscellaneous adjustments noted are customer responsibility. Proper attention to preventative maintenance and scheduled maintenance procedures will prolong the life of the appliance.
7. Travel mileage is limited to **sixty (60) miles** from an Authorized Service Agency or one of its sub-service agencies.
8. All labor shall be performed during regular working hours. Overtime premium will be charged to the buyer.
9. All genuine Wells replacement parts are warranted for ninety (90) days from date of purchase on non-warranty equipment. This parts warranty is limited only to replacement of the defective part(s). **Any use of non-genuine Wells parts completely voids any warranty.**
10. Installation, labor, and job check-outs are **not** considered warranty and are thus **not** covered by this warranty.
11. Charges incurred by delays, waiting time or operating restrictions that hinder the service technician's ability to perform service are **not** covered by warranty. This includes institutional and correctional facilities.

SHIPPING DAMAGE CLAIM PROCEDURE

NOTE: For your protection, please note that equipment in this shipment was carefully inspected and packaged by skilled personnel before leaving the factory. Upon acceptance of this shipment, the transportation company assumes full responsibility for its safe delivery.

IF SHIPMENT ARRIVES DAMAGED:

1. **VISIBLE LOSS OR DAMAGE:** Be certain that any visible loss or damage is noted on the freight bill or express receipt, and that the note of loss or damage is signed by the delivery person.
2. **FILE CLAIM FOR DAMAGE IMMEDIATELY:** Regardless of the extent of the damage.

3. **CONCEALED LOSS OR DAMAGE:** if damage is unnoticed until the merchandise is unpacked, notify the transportation company or carrier immediately, and file "CONCEALED DAMAGE" claim with them. This should be done within fifteen (15) days from the date the delivery was made to you. Be sure to retain the container for inspection.

Wells Manufacturing cannot assume liability for damage or loss incurred in transit. We will, however, at your request, supply you with the necessary documents to support your claim.

TABLE OF CONTENTS

WARRANTY	xi
SPECIFICATIONS	1
FEATURES & OPERATING CONTROLS	2
PRECAUTIONS & GENERAL INFORMATION	4
AGENCY LISTING INFORMATION	4
INSTALLATION	5
OPERATION	8
CLEANING INSTRUCTIONS	10
PREVENTATIVE MAINTENANCE	
Hinge Adjustment	12
TROUBLESHOOTING SUGGESTIONS	13
EXPLODED VIEW and PARTS LIST	14
WIRING DIAGRAM	18
PARTS & SERVICE	19
CUSTOMER SERVICE DATA	19

INTRODUCTION

Thank You for purchasing this Wells Manufacturing Co. appliance.

Proper installation, professional operation and consistent maintenance of this appliance will ensure that it gives you the very best performance and a long, economical service life.

This manual contains the information needed to properly install this appliance, and to use and care for the appliance in a manner which will ensure its optimum performance.

SPECIFICATIONS

DIMENSIONS	APPLIANCE	OVEN CAVITY
Wide	30-1/8" (765mm)	14-3/8" (365mm)
Deep	25-1/4" (641mm) oven only 27-7/8" (682mm) incl. handle	21" (533mm)
High	25-1/8" (638mm) oven only 34" (863mm) incl. prep-top\ and casters	20" (508mm)
Door Swing	20" (508mm) radius	
 ELECTRICAL		
	208 VAC 3ø 60Hz	21 Amps per leg
	240 VAC 3ø 60Hz	21 Amps per leg

Note: Shipped from the factory 3 phase.
Unit is NOT approved for conversion to single phase

FEATURES & OPERATING CONTROLS

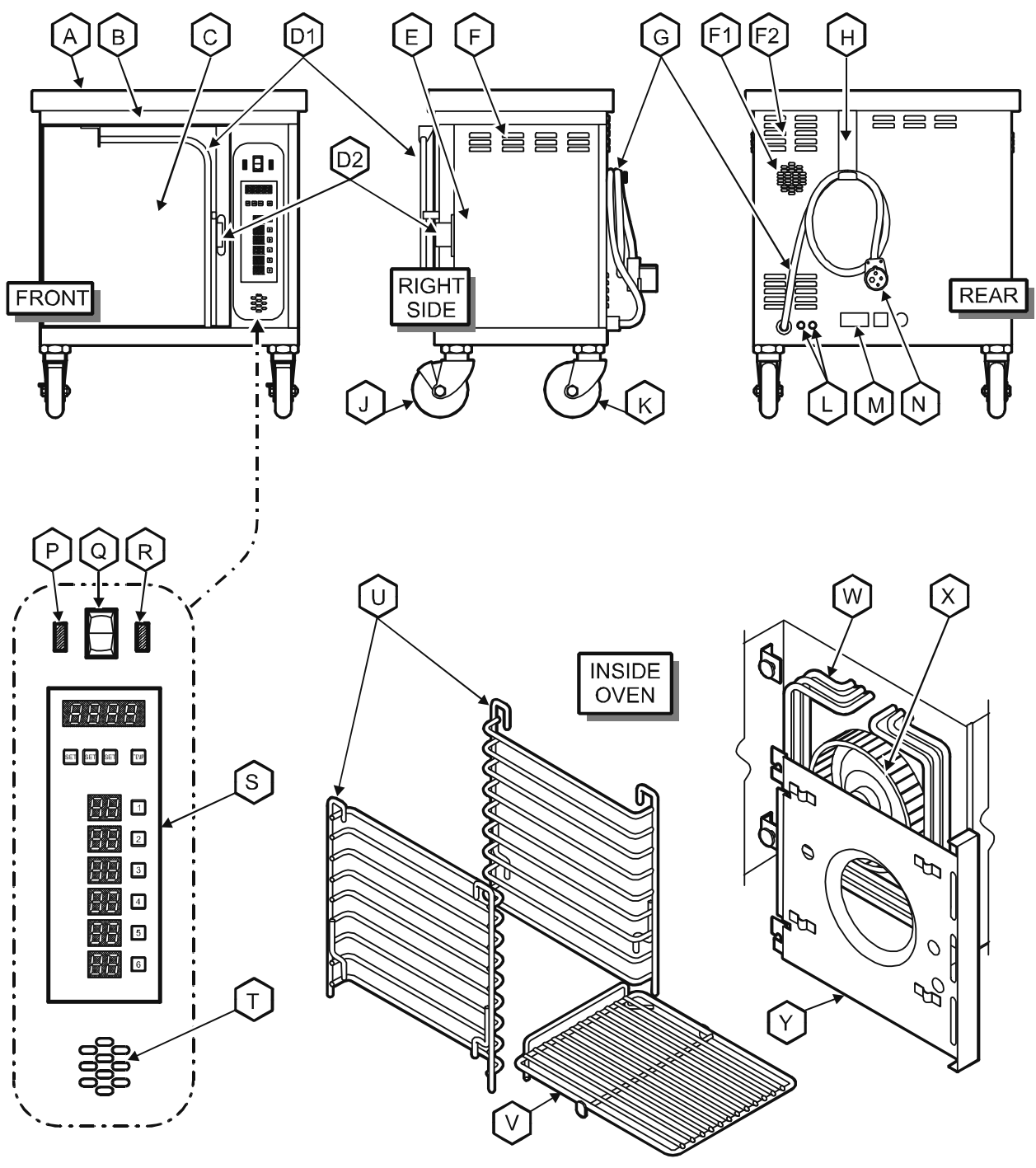

903 2M-45633 Owners Manual M4200-3S Floor Convection Oven, MacD

FEATURES & OPERATING CONTROLS (continued)

ITEM	DESCRIPTION	FUNCTION
A. OPTIONAL PREP TOP	Allows top of oven to be used as a work surface	
B. OVEN TOP	Covers and protects top insulation	
C. OVEN DOOR	Covers and provides access to oven cavity	
D1. DOOR HANDLE	Safe hand hold to open or close oven.	
D2. DOOR STRIKER & LATCH	Striker and door- mounted latch hold oven door closed	
E. ACCESS PANEL	Covers and provides access to fan motor and electric connections and controls	
F1. COOLING FAN INLET	Provides air circulation for cooling. DO NOT spray or pour water into cooling fan inlet or louvers	
F2. COOLING LOUVERS		
G. POWER CORD	Supplies power from receptacle to oven	
H. CORD HANGER	Provides storage for cord when moving oven	
J. OPTIONAL FRONT CASTERS	Allow oven to be easily moved; locking to stabilize oven when in position	
K. OPTIONAL REAR CASTERS	Allow oven to be easily moved.	
L. POWER FUSES	Protect electrical circuits from overload	
M. DATA PLATE	Provides manufacturer, model and serial number information. Also, provides electrical specifications and requirements	
N. POWER PLUG	Plugs into power receptacle	
P. HEAT ON LIGHT	Glowes amber when heating elements are energized	
Q. ON/OFF/FAN SWITCH	Turns oven and fan, or fan only, on or off	
R. POWER ON LIGHT	Glowes red when power is turned on	
S. SOLID STATE CONTROL	Controls cooking times and temperatures; programmable. DO NOT spray or pour water into controller	
T. BEEPER	Audible indicator for alarms, end-of-cycle, etc.	
U. RACK SUPPORTS	Hold cooking racks	
V. PRODUCT RACK	Holds product to be cooked	
W. HEATING ELEMENTS	Provide cooking heat when energized	
X. FAN	Circulates heated air during cooking	
Y. FAN BAFFLE	Covers fan, also provides mounting for right rack support	

PRECAUTIONS AND GENERAL INFORMATION



WARNING: Electric Shock hazard

All servicing requiring access to non-insulated electrical components must be performed by a factory authorized technician.
DO NOT open any access panel which requires the use of tools. Failure to follow this warning can result in severe electrical shock.



CAUTION: Risk of Damage

DO NOT connect or energize this appliance until all installation instructions are read and followed. Damage to the appliance will result if these instructions are not followed.



CAUTION: Hot Surface

Exposed surfaces can be hot to the touch and may cause burns.

This appliance is intended for use in commercial establishments only.

This appliance is intended to prepare food for human consumption. No other use is recommended or authorized by the manufacturer or its agents.

Operators of this appliance must be familiar with the appliance use, limitations and associated restrictions. Operating instructions must be read and understood by all persons using or installing this appliance.

Cleanliness of this appliance is essential to good sanitation. Read and follow all included cleaning instructions and schedules to ensure the safety of the food product.

Disconnect this appliance from electrical power before performing any maintenance or servicing.

DO NOT submerge this appliance in water. This appliance is not jet stream approved. Do not direct water jet or steam jet at this appliance, or at any control panel or wiring. Do not splash or pour water on, in or over any controls, control panel or wiring. Do not wash floor around this appliance with water or steam jet.

Exposed surfaces of this appliance can be hot to the touch and may cause burns.

Do not operate this appliance if the control panel is damaged. Do not operate this appliance if the keypad section of the control panel is torn or broken. Call your Authorized Wells Service Agent for service.

The technical content of this manual, including any wiring diagrams, schematics, parts breakdown illustrations and/or adjustment procedures, is intended for use by qualified technical personnel.

Any procedure which requires the use of tools must be performed by a qualified technician.

This manual is considered to be a permanent part of the appliance. This manual and all supplied instructions, diagrams, schematics, parts breakdown illustrations, notices and labels must remain with the appliance if it is sold or moved to another location.

This appliance is made in the USA. Unless otherwise noted, this appliance has American sizes on all hardware.

AGENCY LISTING INFORMATION



STD 4



E6070

This appliance conforms to NSF Standard 4 for sanitation only if installed in accordance with the supplied *Installation Instructions* and maintained according to the instructions in this manual.

This appliance is  Listed under UL File E6070 for 208V and 240V.

UNPACKING & INSPECTION

Carefully remove the appliance from the carton. Remove all protective plastic film, packing materials and accessories from the Appliance before connecting electrical power or otherwise performing any installation procedure.

Carefully read all instructions in this manual and the *Installation Instruction Sheet* packed with the appliance before starting any installation.

Read and understand all labels and diagrams attached to the appliance.

Carefully account for all components and accessories before discarding packing materials. Store all accessories in a convenient place for later use.

COMPONENTS

- 3 ea. OVEN RACKS
- 2 ea. RACK SUPPORTS
- 1 ea. FAN BAFFLE

ACCESSORIES

- 1 ea. LITERATURE PACKAGE

SERVICE TECHNICIAN INSTALLATION NOTES

1. Installation and start up should be performed by an authorized installation company. Installer must record installation particulars on the *CUSTOMER SERVICE DATA* form on page 21 of this manual.
2. Verify that this equipment installation is in compliance with the specifications listed in this manual and with local code requirements.

NOTE: DO NOT discard the carton or other packing materials until you have inspected the appliance for hidden damage and tested it for proper operation. Refer to *SHIPPING DAMAGE CLAIM PROCEDURE* on the inside front cover of this manual.

**WARNING:**
**Risk of
personal injury**

Installation procedures must be performed by a qualified technician with full knowledge of all applicable electrical and plumbing codes. Failure can result in personal injury and property damage.

IMPORTANT:
It is the **RESPONSIBILITY OF THE INSTALLER** to check with the **AUTHORITY HAVING JURISDICTION**, in order to verify compliance with local codes and ordinances for **THIS SPECIFIC EQUIPMENT INSTALLATION**.

INSTALLATION (continued)



WARNING: **Electric** **Shock hazard**

All servicing requiring access to non-insulated electrical components must be performed by a factory authorized technician. DO NOT open any access panel which requires the use of tools. Failure to follow this warning can result in severe electrical shock.

EQUIPMENT SET-UP

1. CURB or COUNTER MOUNTING
 - a. Setup the appliance only on a firm, level, non-combustible surface. Verify local codes for requirements. Concrete, tile, terrazzo or metal surfaces are recommended. Metal over combustible material may not meet code for non-combustible surfaces.
 - b. Appliance is approved for installation with zero clearance at bottom.
 - c. Recommend at least 3" clearance on sides and back to allow adequate air flow.
2. INSTALLING OPTIONAL CASTERS
 - a. Install casters, one on each corner of the appliance, in the holes provided. Locking casters must be installed on the FRONT of the appliance.
 - b. Set up the appliance only on a firm, level, non-combustible surface. Verify local codes for requirements. Concrete, tile, terrazzo or metal surfaces are recommended. Metal over combustible material may not meet code for non-combustible surfaces.
 - c. LEVELING: Verify that the appliance sits firmly on all four casters when in its normal operational position. With a spirit level, check that the appliance is level front-to-back and side-to-side.
3. INSTALLING OPTIONAL LEGS (NOTE: Legs are not provided and must be purchased separately.)
 - a. Install adjustable legs, one on each corner of the appliance, in the holes provided.
 - b. Set up the appliance only on a firm, level, non-combustible surface. Verify local codes for requirements. Concrete, tile, terrazzo or metal surfaces are recommended. Metal over combustible material may not meet code for non-combustible surfaces.
 - c. LEVELING: Verify that the appliance sits firmly ON ALL FOUR LEGS. With a spirit level, check that the appliance is level front-to-back and side-to-side.
4. INSTALLING ON FABRICATED MOUNTING
 - a. Mounting must be capable of safely supporting 350 pounds (165 Kg.), and must be fabricated to the dimensions shown at left:
 - b. Attach the appliance securely to the mounting with four 3/4"-10 x 1" bolts.

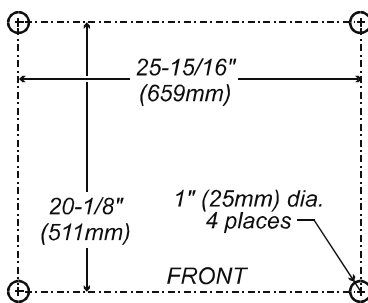

DIMENSIONS
Fabricated Mounting



DANGER: ELECTRICAL SHOCK HAZARD
ELECTRICAL CONNECTIONS MUST BE MADE BY A
LICENSED ELECTRICIAN
Electrical shock will cause death or serious injury.

Refer to the nameplate on the front of the appliance.

- Verify the ELECTRICAL SERVICE POWER.
- Voltage and phase must match the nameplate specifications, and available electrical service amperage must meet or exceed the specifications listed on page 1.
- Wiring must be no less than 4 AWG solid copper wire, rated for at least 90°C.

NOTE: Wire gauge, insulation type and temperature rating, as well as type, size and construction of conduit, must meet or exceed applicable specifications of local codes and of the National Electrical Code.

This appliance is equipped with a Hubble™ L430P9 plug, which must be plugged into a matching Hubble™ L430R9 receptacle. The ground lug of the receptacle must be connected to a suitable building ground.

IMPORTANT:

The appliance is shipped from the factory wired for 3-phase (3Ø) electrical service. This appliance is not approved for 1Ø operation. Conversion of this appliance to single-phase operation will void the warranty



CAUTION:
Risk of
Damage

DO NOT connect or energize this appliance until all installation instructions are read and followed. Damage to the appliance will result if these instructions are not followed.



CAUTION:
Electrical Shock
Hazard

The ground lug of this appliance must be connected to a suitable building ground.

IMPORTANT:

Contact a licensed electrician to install and connect electrical power to the appliance.

IMPORTANT:

Damage due to being connected to the wrong voltage or phase is NOT covered by warranty.

OPERATION



CAUTION: Hot Surface

Exposed surfaces can be hot to the touch and may cause burns.

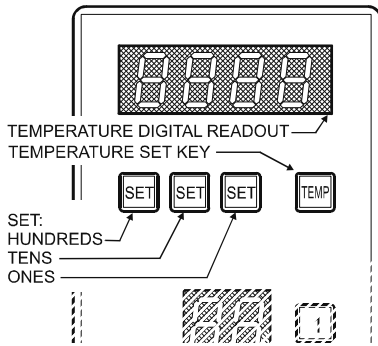

IMPORTANT: Failure to press the TEMP key within 30 seconds of programming the new oven set temperature will cause the controller to revert to original temperature setting and delete latest changes.

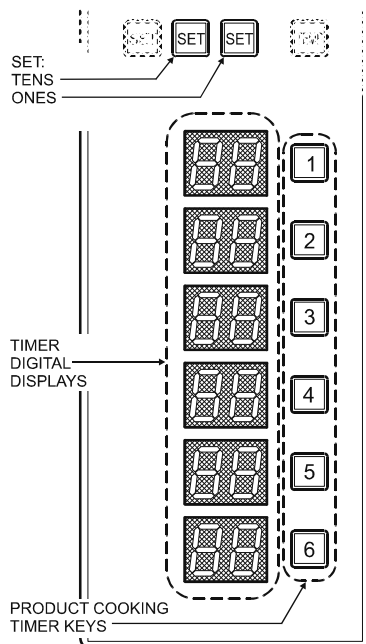

SET TEMPERATURE

1. Make sure the power cord is plugged into the appropriate power supply receptacle.
2. Place the ON/OFF/FAN switch in the ON position.

NOTE: No display will be present until the TEMP key is pressed.

3. Press the TEMP key momentarily to display the current oven temperature. The display will hold for 5 seconds.
4. Press the TEMP button and hold for 3 seconds. The current set temperature will display and flash. The controller is now in the programming mode.
5. Use the 3 SET keys to set hundreds, tens and ones for the desired oven set temperature. The corresponding digit on the digital readout will increase from 0 to 9. Release the SET key when the desired digit is displayed.
6. Press the TEMP key to exit the programming mode. The new set temperature will automatically be stored in memory.
7. The maximum temperature to which the controller can be programmed is 500°F (260°C). Any attempt to set the oven temperature higher than 500°F (260°C) will cause the controller to reset the temperature to 500°F (260°C).

NOTE: The "actual temperature" displayed may read higher than set point during pre-heat until oven temperature has stabilized.

SET TIMER

1. Make sure the power cord is plugged into the appropriate power supply receptacle.
2. Place the ON/OFF/FAN switch in the ON position.
3. In the IDLE mode, the digital timer displays will be at "low" intensity, and will brighten while active and counting down. Verify that the time being displayed on each of the timer digital displays is correct. If not, proceed as follows:
4. Example: Set TIMER 1
 - a. Press and hold TIMER key 1 and SET key for ONES. The right digit of timer display 1 will brighten and begin to cycle through 0 to 9. Release both keys when the desired digit is reached.
 - b. Press and hold TIMER key 1 and SET key for TENS. The left digit of timer display 1 will brighten and begin to cycle through 0 to 9. Release both keys when the desired digit is reached. When the keys are released, the display will return to IDLE mode and the new settings will be retained in memory.
5. TIMER keys 2 through 6 may be set in the same manner.

DAILY SET-UP PROCEDURES

1. Make sure the power cord is plugged into the appropriate power supply receptacle.
2. Recommended shelf positions for quality baked products:

NO. OF PANS OF PRODUCT	RACK POSITION UTILIZED
1	5
2	2 & 8
3	2, 5 & 8

3. Place the ON/OFF/FAN switch in the ON position. The green POWER ON light will glow.
4. Check oven set temperature. Press and hold the TEMP key for 5 seconds or until the screen flashes the current set temperature. If this is not right, refer to and follow the step-by-step procedure for "Set Temperature", page 8.
5. If the oven set temperature is correct, press the key again to clear the display.
6. Ensure that the door is closed. The amber HEAT light will glow, indicating that the heaters are on.
7. Allow the oven to preheat for 30 minutes.
8. When the amber HEAT light goes out, the oven is ready to use. From then on the amber HEAT light will cycle on and off with the heaters (i.e. light will glow when the heaters are on).
9. Check to see that the timers are set for the correct times. If not, see "Set Timer", page 8.

D. OVEN OPERATION

1. Make sure the power cord is plugged into the appropriate power supply receptacle.
2. Place the ON/OFF/FAN switch in the ON position.
3. Verify that the time being displayed on each of the timer digital displays is correct. If not, see "Set Timer", page 8.
4. To start a product cook timer, press the corresponding PRODUCT COOKING TIMER key once.

The digital display will brighten and a timing dot will appear in the lower right-hand corner of the display. The timer will automatically begin to countdown. The timer display will show the time remaining in the cook cycle.

5. When the timer reaches "00", a three-tone audible alarm will sound, and the display will blink.
6. To stop the audible alarm, or to cancel a timer operation, press the corresponding PRODUCT COOKING TIMER key once.

The display will change to IDLE mode (low intensity), the timing indicator dot will turn off, and the audible tone will be cancelled.



CAUTION:
Hot Surface

Exposed surfaces can be hot to the touch and may cause burns.

SUGGESTION: The product timer can be used for timing the preheat time.

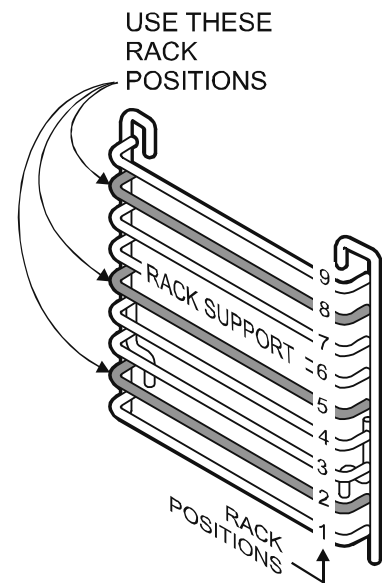

CLEANING INSTRUCTIONS

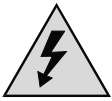

CAUTION: Electric Shock Hazard

Disconnect appliance from electric power before cleaning.



CAUTION: Burn Hazard

Allow appliance to cool completely before cleaning.

Do not attempt to clean the oven until it has cooled to 150°F or less. It can burn you. Hand protection is required.



CAUTION: Cut Hazard

FAN BLADES ARE SHARP. Use due care when cleaning and/or wiping.

IMPORTANT: DO NOT spill or pour water into controls, control panel or wiring.

Damage to internal components from water damage is **not** covered by warranty.

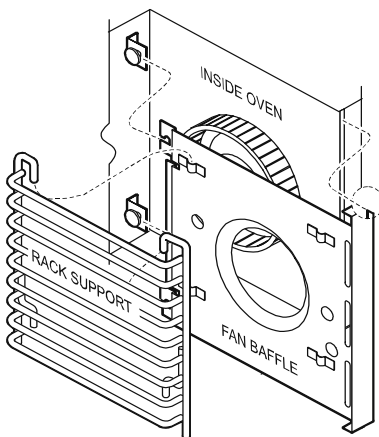

Assembling Fan Baffle
& Rack Support

PREPARATION Allow oven to cool to 150°F or less

FREQUENCY Daily

TOOLS Fiber Brush,
Mild Detergent, McD Sanitizer,
Clean Towel

CLEANING

1. Turn POWER SWITCH to *FAN*. With the door held open, allow the oven to cool. When the oven interior has cooled to 150°F or less, turn the POWER SWITCH to *OFF*.
2. Remove racks and rack supports. Remove fan baffle.
3. Brush the fan wheel and wipe it with a moist cloth. Sponge out all loose particles.
4. Wipe down the entire interior using a clean cloth moistened with hot water and a mild detergent. Rinse by wiping with a clean towel moistened with sanitizer.

IMPORTANT: Always wipe or rub in the direction of the polish lines or grain of the metal.

5. Clean oven racks and rack supports in a sink or dishwasher.
6. Reinstall the fan baffle, paying particular attention that the lip on the right side of the fan baffle is fully seated in the slot in the edge of the oven cavity. Reinstall rack supports and racks.

IMPORTANT: Take care to avoid damage to fan blades when reinstalling fan baffle.

7. Turn power switch to *FAN*. Verify that fan runs smoothly and does not contact fan baffle. Turn power switch to *OFF*. Reposition fan baffle if necessary.
8. Wipe down the prep top and exterior of the oven using a clean cloth moistened with hot water and a mild detergent. Rinse by wiping with a clean towel moistened with sanitizer.

IMPORTANT: Always wipe or rub in the direction of the polish lines or grain of the metal.

9. Replace oven rack supports. Leave the door open overnight.

PROCEDURE IS COMPLETE

CLEANING INSTRUCTIONS (continued)

PREPARATION Allow oven to cool to 150°F or less

FREQUENCY Weekly

TOOLS Fiber Brush, Plastic Scouring Pad, Plastic Scraper
Mild Detergent, McD Sanitizer,
APC All Purpose Cleaner, Clean Towel

CLEANING

1. Turn POWER SWITCH to *FAN*. With the door held open, allow the oven to cool. When the oven interior has cooled to 150°F or less, turn the POWER SWITCH to *OFF*.
2. Remove racks and rack supports. Remove fan baffle.
3. Brush the fan wheel and wipe it with a moist cloth. Sponge out all loose particles.
4. Scrub entire interior of convection oven with a plastic scouring pad and APC cleaner.
5. For baked-on food spills, apply APC cleaner. Close the oven door, place the ON/OFF/FAN switch in the OFF position. Let stand for 10 minutes. Carefully wipe all cleaner and food residue from all interior surfaces. Wipe with sanitizer.
6. Wipe down the entire interior using a clean cloth or moistened with hot water and a mild detergent. Rinse by wiping with a clean towel moistened with sanitizer.

IMPORTANT: Always wipe or rub in the direction of the polish lines or grain of the metal.

7. Clean oven racks and rack supports in a sink or dishwasher.
8. Reinstall the fan baffle, paying particular attention that the lip on the right side of the fan baffle is fully seated in the slot in the edge of the oven cavity. Reinstall rack supports and racks.

IMPORTANT: Take care to avoid damage to fan blades when reinstalling fan baffle.

9. Turn power switch to *FAN*. Verify that fan runs smoothly and does not contact fan baffle. Turn power switch to *OFF*. Reposition fan baffle if necessary.
10. Wipe down the prep top and exterior of the oven using a clean cloth moistened with hot water and a mild detergent. A plastic scouring pad may be used to removed baked-on food debris. Rinse by wiping with a clean towel moistened with sanitizer.

IMPORTANT: Always wipe or rub in the direction of the polish lines or grain of the metal.

11. Replace oven rack supports. Leave the door open overnight.

PROCEDURE IS COMPLETE



CAUTION:
**Electric Shock
Hazard**

Disconnect appliance from electric power before cleaning.



CAUTION:
Burn Hazard

Allow appliance to cool completely before cleaning.

Do not attempt to clean the oven until it has cooled to 150°F or less. It can burn you. Hand protection is required.



CAUTION:
Cut Hazard

FAN BLADES ARE SHARP. Use due care when cleaning and/or wiping.

IMPORTANT: DO NOT spill or pour water into controls, control panel or wiring.

Damage to internal components from water damage is **not** covered by warranty.

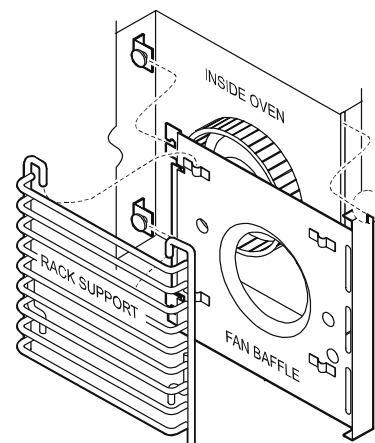

*Assembling Fan Baffle
& Rack Support*

PREVENTATIVE MAINTENANCE



CAUTION: Burn Hazard

Allow appliance to cool completely before adjusting.

HINGE ADJUSTMENT

PRECAUTIONS: None

FREQUENCY: Monthly, at a Minimum; or, As Needed

TOOLS: Phillips (+) Screwdriver
7/16" Nut Driver
7/8" and 1-1/8" Wrenches

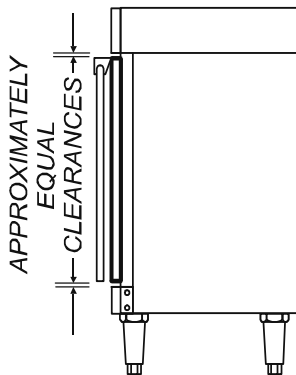
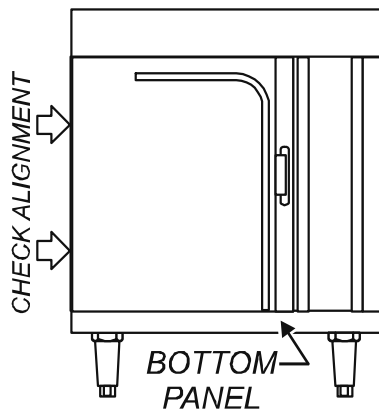

Hinge Adjustment

THE FOLLOWING PROCEDURE IS TO BE PERFORMED BY QUALIFIED PERSONNEL ONLY

1. Remove bottom panel to access pivot.

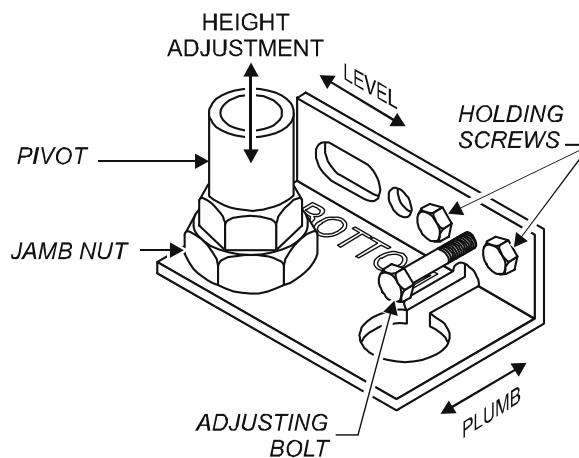

2. Gap between top of door and frame, and between bottom of door and frame must be approximately equal

Adjust height of door by loosening jamb nut, then turning pivot on its screw mounting. Clockwise lowers the door height. Re-tighten jamb nut.

3. Gap between left side of door and frame must be the same from top to bottom

Adjust door for plumb by loosening holding screws. Turn adjusting bolt to increase or decrease gap at bottom. Clockwise increases gap. Re-tighten holding screws.

4. Gap between top of door and frame must be the same from side to side

Adjust door for level by loosening holding screws, then raising or lowering latch-end of door until it is level. Re-tighten holding screws.

5. Reinstall bottom panel.

Procedure is complete

TROUBLESHOOTING SUGGESTIONS

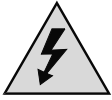

CAUTION: Electrical Shock Hazard

Removal of any cabinet panel will result in exposed electrical circuits. Any procedure requiring the removal of any cabinet panel must be performed by a qualified technician only.

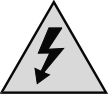

CAUTION: Electrical Shock Hazard

Fuse replacement may expose dangerous voltages. Fuse replacement must be performed by a qualified technician.

SYMPTOM	POSSIBLE CAUSE	SUGGESTED REMEDY
No power to appliance	Circuit breaker off or tripped	Reset circuit breaker
	Power cord unplugged or damaged	Check power cord Plug in or repair as required
	Fuse blown or loose	Check power fuses. If blown, correct problem and replace fuses
Oven will not heat	Power switch turned to OFF or FAN	Turn power switch ON
	Temperature control not set	Set to desired temperature
	Oven door not closed	Be sure door is closed and latched
	Hi-limit control tripped on excessive oven temperature	Allow oven to cool Hi-limit will reset
	Damaged controller	Contact Authorized Wells Service Agency for repairs
Blower fan will not run	Fan switch OFF	Turn fan switch to HIGH or LOW
	Damage to internal components	Contact Authorized Wells Service Agency for repairs
Door pops open during cook cycle	Latch out of adjustment	Adjust latch

NOTE: There are no user serviceable components in the appliance. In all cases of damage or component malfunction, contact your Authorized Wells Service Agency for repairs.

EXPLODED VIEW and PARTS LIST

M4200 Cabinet & Related Components

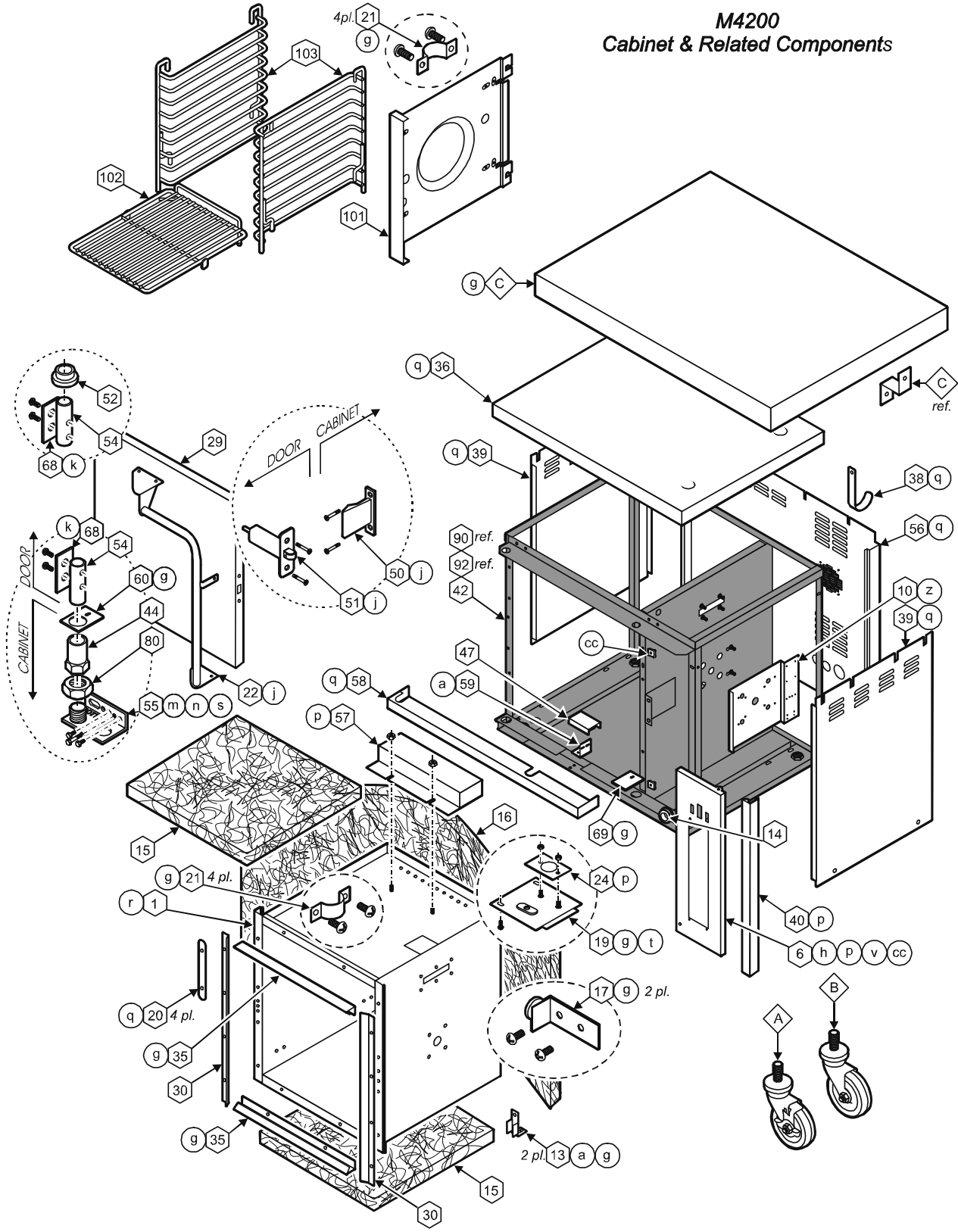

903 2M-45633 Owners Manual M4200-3S Floor Convection Oven, Mcd

EXPLODED VIEW and PARTS LIST (continued)

M4200-3S Cabinet & Related Components

item	description	svc p/n	qty
1	ASSY, CAVITY		1
6	PANEL, CONTROL	DD-49763	1
10	BRACKET, MOTOR MOUNT		1
13	BRACKET, CAVITY SUPPORT		2
14	GROMMET, 7/8" O.D.	2K-31040	2
15	INSULATION, TOP & BOTTOM		2
16	INSULATION, WRAP		1
17	ASSY, BAFFLE SUPPORT		2
19	MOUNT, TEMP SENSORS		1
20	COVER, DOOR GASKET		4
21	CLIP, RACK SUPPORT	F6-43889	8
22	HANDLE ASSEMBLY		1
23	LIGHT, SIGNAL "HEAT"	2J-45145	1
24	BRACKET, HI-LIMIT THERMO		1
29	ASSY, DOOR COMPLETE	F6-504444	1
30	GASKET, DOOR, SIDE	F6-46313	2
35	GASKET, DOOR, TOP/BOT	F6-46314	2
36	ASSY, OVEN TOP		1
38	HANGER, CORD		1
39	PANEL, EXTERIOR SIDE		2
40	TRIM, RIGHT FRONT		1
42	ASSY, FRAME		1
44	SLEEVE, DOOR HINGE	2A-43900	1
47	GUARD, PROX. SWITCH	F6-45647	1
50	DOOR STRIKER	2C-305616	1
51	DOOR LATCH	2C-305615	1
52	BUSHING, TOP DOOR HINGE	2K-305619	1
54	PIN, HINGE, DOOR TOP AND BOTTOM	2A-305610	2
55	ASSY, BOT DOOR HINGE	F6-43896	1
56	PANEL, REAR		1
57	ASSY, VENT DUCT		1
58	TRIM, LOWER FRONT	F6-43804	1
59	BRACKET, PROX SWITCH	F6-43787	1
60	PLATE, DOOR PIVOT	F6-43899	1
68	PLATE, DOOR HINGE PIN		2
69	PLATE, DOOR PIVOT HOLE	F6-43899	1
80	NUT, HEX 3/4-10 UNC		1
90	WIRE SET (not shown)		1
92	TIE, WIRE, STANDOFF (not shown)		2
101	BAFFLE, OVEN		1
102	RACK, PRODUCT	5F-21376	3
103	SUPPORT, RACK (pk 2)	5F-21375	2
cc	CLIP, TINNEMAN	2C-37943	
A	CASTER, LOCKING (FRONT)	5F-21373	2
B	CASTER, SWIVEL (REAR)	5F-21372	2
C	PREP TOP	5F-21445	1
	CLIP, PREP TOP		4
a	SCREW, 8-32 x 1/2 FH	p	NUT, HEX 8-32 KEP
g	SCREW, 8-32 x 1/2 SS	q	SCREW, 8-32 x 1/2 PH SS
h	SCREW, 8-32 x 7/8 Pan	r	SCREW, 10-32 x 1/2 PH SS
j	SCREW, 10-32 x 1-1/2 FH	s	WASHER, FLAT 1/4
k	SCREW, 1/4-20 x 5/8 RH	t	WASHER, LOCK #8
m	BOLT, 1/4-20 x 3/4 HEX	v	WASHER, FLAT #8
n	BOLT, 1/4-20 x 1-1/4 HEX	z	NUT, HEX 10-32

EXPLODED VIEW and PARTS LIST (continued)

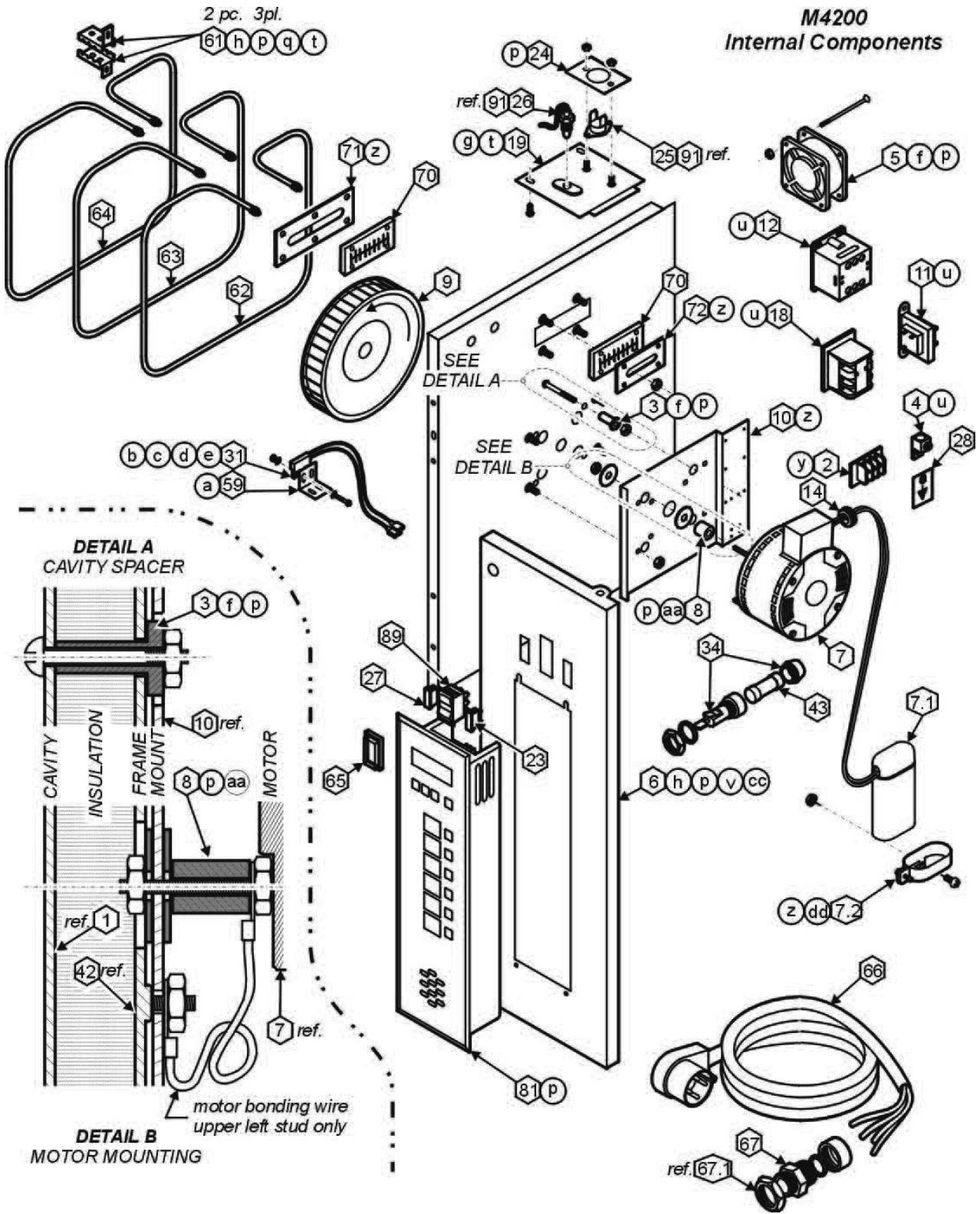

903 2M-45633 Owners Manual M4200-3S Floor Convection Oven, MacD

EXPLODED VIEW and PARTS LIST (continued)

M4200-3S Internal Components

item	description	svc p/n	qty
1	ASSY, CAVITY		1
2	TERMINAL BLOCK, 3 POLE	WS-50131	1
3	SPACER, BLOWER MOTOR		4
4	LUG, SOLDERLESS		1
5	FAN, COOLING	2U-44687	1
6	PANEL, CONTROL	DD-49763	1
7	MOTOR, 1/4 HP	WS-63932	1
7.1	START CAPACITOR	WS-69823	1
7.2	BRACKET, START CAPACITOR	2V-300933	1
8	SPACER, MOTOR MOUNT		4
9	BLOWER WHEEL	2U-43797	1
10	BRACKET, MOTOR MOUNT		1
11	TRANSFORMER, 240V - 16V	DD-43929	1
12	RELAY, ESAFE 230V 3ø	2E-306967B	1
14	GROMMET, 7/8" O.D.	2K-31040	2
18	RELAY, 208/240V SPNO	2E-43880	1
24	BRACKET, HI-LIMIT THERMO		1
25	THERMOSTAT, HI-LIMIT	2T-45180	1
26	THERMOCOUPLE	WS-63927	1
27	LIGHT, SIGNAL "POWER"	2J-45146	1
28	LABEL, GROUND SYMBOL	64584	1
31	ASSY, PROXIMITY SWITCH	F6-45239	1
34	FUSEHOLDER, 10A 240V	2E-34769	2
42	ASSY, FRAME	69775	1
43	FUSE, 10A 240V	2E-34768	2
59	BRACKET, PROX SWITCH	F6-43787	1
62.1	INNER ELEMENT, 208V (4" GAP)	2N-43872UL	1
62.2	INNER ELEMENT, 240V (4" GAP)	2N-43783UL	1
63.1	MIDDLE ELEMENT, 208V (2.5" GAP)	2N-43866UL	1
63.2	MIDDLE ELEMENT, 240V (2.5" GAP)	2N-43800UL	1
64.1	OUTER ELEMENT, 208V (1" GAP)	2N-43873UL	1
64.2	OUTER ELEMENT, 240V (1" GAP)	2N-43949UL	1
65	BOOT, CLEAR SILICON	2E-43738	1
66	ASSY, POWER CORD		1
67	STRAIN RELIEF	2K-48754	1
67.1	NUT (ONLY), STRAIN RELIEF	2C-45504	
70	GASKET, ELEMENT	2I-43834	1
71	COVER, ELEMENT GASKET INNER	F6-43836	1
72	COVER, ELEMENT GASKET OUTER	F6-43837	1
81	OVEN CONTROLLER	WS-64964	1
81.1	OVERLAY, CONTROLLER	WS-500975	1
89	SWITCH, ON/OFF	2E-43918	1
90	WIRE SET (not shown)		1
91	SLEEVEING, FIBREGLASS (not shown)		1
92	TIE, WIRE, STANDOFF (not shown)		2
93	OP. MANUAL M4200 (not shown)	2M-45633	1
a	SCREW, 8-32 x 1/2 FH	p	NUT, HEX 8-32 KEP
b	SCREW, 4-40 x 3/8 RH	q	SCREW, 8-32 x 1/2 PH SS
c	WASHER, FLAT #4	t	WASHER, LOCK #8
d	WASHER, LOCK #4	u	SCREW, 8-32 x 3/8 PH PAN
e	NUT, HEX 4-40	v	WASHER, FLAT #8
f	SCREW, 8-32 x 2 PH	y	SCREW, 6-32 x 7/8 SS
g	SCREW, 8-32 x 1/2 SS	z	NUT, HEX 10-32
h	SCREW, 8-32 x 7/8 PAN	aa	FENDER WASHER, #8
cc	CLIP, TINNEMAN 2C-37943	dd	SCREW, 10-32 x 1/2 PH

WIRING DIAGRAM FOR M4200-3, -3S CONVECTION OVEN
208 OR 240 VOLTS, 3 PHASE

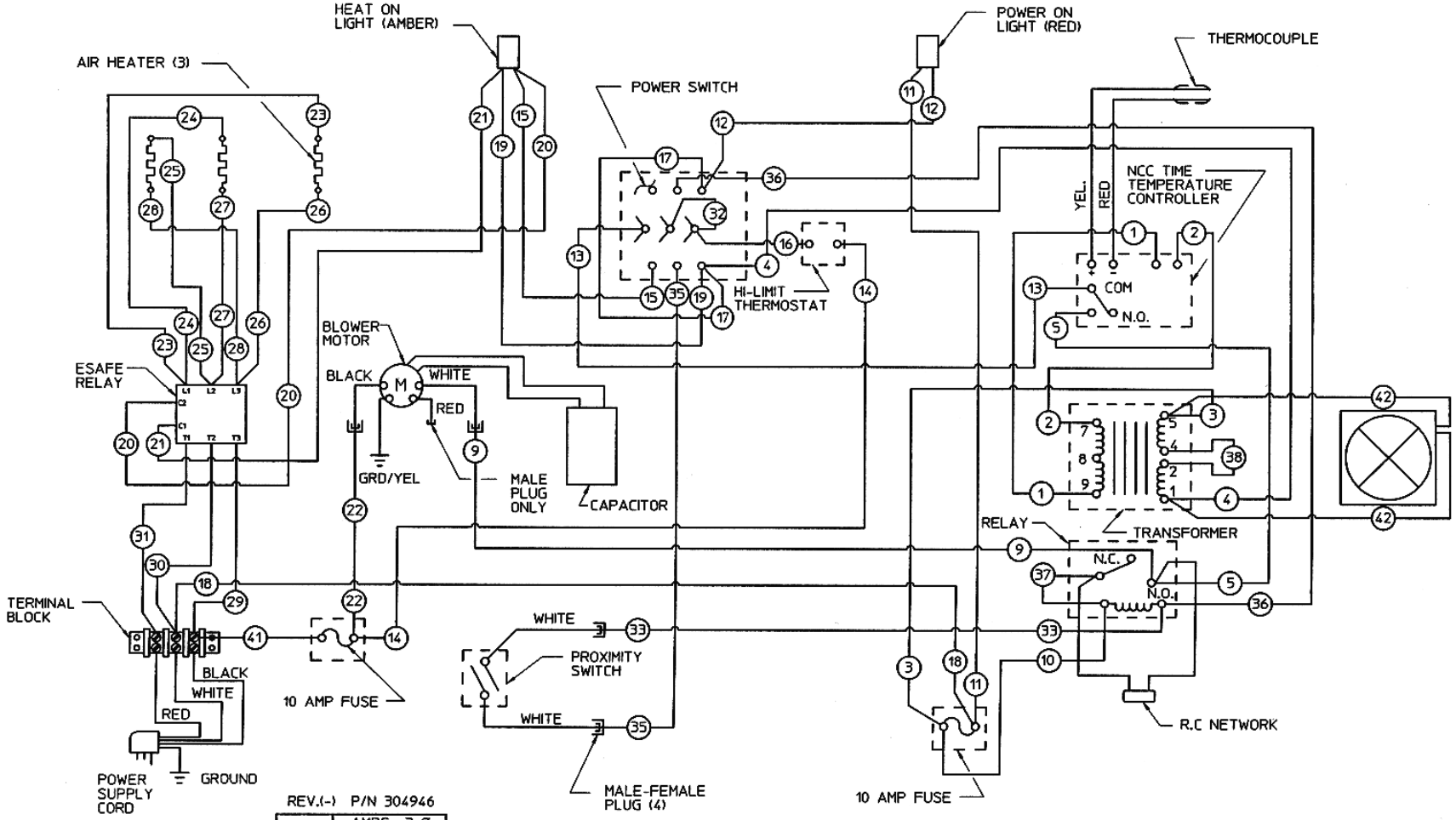

REV.(-) P/N 304946

VOLTS	AMPS 3 Ø		
	L1	L2	L3
208	21	21	21
240	21	21	21

50/60 HZ

PARTS & SERVICE

DESCRIPTION

PART NO.

CASTER SET, OVEN (set of 4)	21330
OVEN STACKING KIT	21342
CASTER, SWIVEL (set of 2)	21372
CASTER, LOCKING (set of 2)	21373
OVEN RACK, REPLACEMENT (ea.)	21376
PREP TOP	21445
WALL SPACER KIT	21717
LEG KIT, OVEN, S/S (set of 4)	22226

IMPORTANT: Use only factory authorized service parts and replacement filters.

For factory authorized service, or to order factory authorized replacement parts, contact your Wells authorized service agency, or call:

Wells Manufacturing Co.
 10 Sunnen Dr.
 St. Louis, MO 63143
 phone: (888) 356-5362
 fax: (314) 781-2714
 (Service Parts Dept.)

Service Parts Department can supply you with the name and telephone number of the WELLS AUTHORIZED SERVICE AGENCY nearest you.

CUSTOMER SERVICE DATA

please have this information available if calling for service

RESTAURANT _____	LOCATION _____
INSTALLATION DATE _____	TECHNICIAN _____
SERVICE COMPANY _____	
ADDRESS _____	STATE _____ ZIP _____
TELEPHONE NUMBER (____) _____ - _____	
EQUIPMENT MODEL NO. _____	
EQUIPMENT SERIAL NO. _____	
VOLTAGE: (check one)	208 480



Wells Bloomfield proudly supports CFESA
Commercial Food Equipment Service Association

SERVICE TRAINING - QUALITY SERVICE



CUSTOMER SATISFACTION

PREPARED FOR



BY



WELLS BLOOMFIELD, LLC
10 Sunnen Dr., St. Louis, MO 63143
telephone: 888-356-5362
fax: 314-781-2714
www.wells-mfg.com