

WELLS MANUFACTURING

265 Hobson Street, Smithville, Tennessee 37166
telephone: 314-781-2777
fax: 314-781-2714
www.wells-mfg.com

273

OWNER'S MANUAL

**HALF-SIZE
CONVECTION
OVEN**

MODELS

OC-1

**OC-4TC
with
HOTPLATE
COOKTOP**



OC-1

**Includes
INSTALLATION
USE & CARE
EXPLODED VIEW
PARTS LIST
WIRING DIAGRAM**

IMPORTANT: DO NOT DISCARD THIS MANUAL

This manual is considered to be part of the appliance and is to be given to the OWNER or MANAGER of the restaurant, or to the person responsible for TRAINING OPERATORS of this appliance. Additional manuals are available from your WELLS DEALER.

THIS MANUAL MUST BE READ AND UNDERSTOOD BY ALL PERSONS USING OR INSTALLING THIS APPLIANCE. Contact your WELLS DEALER if you have any questions concerning installation, operation or maintenance of this equipment.

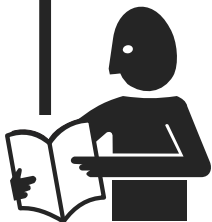

PRINTED IN UNITED STATES OF AMERICA

LIMITED EQUIPMENT WARRANTY

Wells Manufacturing warranties new products to be free from defects in material and/or workmanship for a period of one [1] year from the date of original installation, except as noted below. Defects that occur as a result of normal use, within the time period and limitations defined in this warranty, will at Wells' discretion have the parts replaced or repaired by Wells or a Wells-authorized service agency.

THIS WARRANTY IS SUBJECT TO ALL LISTED CONDITIONS.

Repairs performed under this warranty are to be performed by a Wells-authorized service agency. Wells will not be responsible for charges incurred or service performed by non-authorized repair agencies.

In all cases, the nearest Wells-authorized service agency must be used.

Wells will be responsible for normal labor charges incurred in the repair or replacement of a warrantied product within 50 miles (80.5 km) of an authorized service agency. Time and expense charges for anything beyond that distance will be the responsibility of the owner. All labor will need to be performed during regular service hours. Any overtime premium will be charged to the owner. For all shipments outside the U.S.A. and Canada, please see the International Warranty for specific details.

It is the responsibility of the owner to inspect and report any shipping damage claims, hidden or otherwise, promptly following delivery.

No mileage or travel charges will be honored on any equipment that is deemed portable. In general, equipment with a cord and plug weighing less than 50 lb. (22.7 kg) is considered portable and should be taken or shipped to the closest authorized service agency, transportation prepaid.

CONTACT

Should you require any assistance regarding the operation or maintenance of any Wells equipment; write, phone, fax or email our service department. In all correspondence mention the model number and the serial number of your unit, as well as the voltage or type of gas you are using.

Business hours are 8:00 a.m. to 4:30 p.m. Central Standard Time
 Telephone 314.678.6314
 Fax 314.781.2714
 Email customerservice@star-mfg.com
 www.wells-mfg.com

WARRANTY EXCLUSIONS

THE FOLLOWING WILL NOT BE COVERED UNDER WARRANTY.

- Any product which has not been installed, cleaned, maintained, or used in accordance with the directions published in the appropriate installation sheet and/or owner's manual as well as national and local codes, including incorrect gas or electrical connection. Wells is not liable for any unit which has been mishandled, abused, misapplied, subjected to chlorides, harsh chemicals, or caustic cleaners, damaged from exposure to hard water, modified by unauthorized personnel, damaged by flood, fire, or other acts of nature [or God], or which have an altered or missing serial number.
- Installation, labor, and job checkouts, calibration of heat controls, air and gas burner/bypass/pilot adjustments, gas or electrical system checks, voltage and phase conversions, cleaning of equipment, or seasoning of griddle surface.
- Replacement of fuses or resetting of circuit breakers, safety controls, or reset buttons.
- Replacement of broken or damaged glass components, quartz heating elements, and light bulbs.
- Labor charges for all removable parts in gas charbroilers and hotplates, including but not limited to burners, grates, and radiants.
- Any labor charges incurred by delays, waiting time, or operating restrictions that hinder a service technician's ability to perform service.
- Parts that fail or are damaged due to normal wear or labor for replacement of Items that can easily be replaced during a daily cleaning routine. such as but not limited to silicone belts, PTFE non-stick sheets, knobs, control labels, bulbs, fuses, quartz heating elements, baskets, racks, and grease drawers.
- Components that should be replaced when damaged or worn, but have been field-repaired instead [eg. field-welded fry pots].
- Any loss of business or profits.

ADDITIONAL WARRANTIES

Specialty/chain specific versions may also have additional and/or extended warranties.

PRODUCTS	PARTS	LABOR
universal ventless hoods	2 years	1 year
canopy hoods	2 years	1 year
"Cook'n Hold" equipment [HW10, HWSMP, LLSC7, LLSC7WA, LLSC11, and LLSC11WA]	2 years	1 year
cast iron grates, burners, and burner shields	1 year	
original Wells parts sold to repair Wells equipment	90 days	
Service First	1 year	

TABLE OF CONTENTS

WARRANTY	1
SPECIFICATIONS	1
FEATURES & OPERATING CONTROLS	2
PRECAUTIONS & GENERAL INFORMATION	4
INSTALLATION	5
AGENCY APPROVAL INFORMATION	5
OPERATION	8
COOKING SUGGESTIONS	10
CLEANING INSTRUCTIONS	11
TROUBLESHOOTING SUGGESTIONS	13
PREVENTATIVE MAINTENANCE	14
EXPLODED VIEW & PARTS LIST	16
WIRING DIAGRAM	21
PARTS & SERVICE	25
CUSTOMER SERVICE DATA	25

INTRODUCTION

Thank You for purchasing this Wells Bloomfield appliance.

Proper installation, professional operation and consistent maintenance of this appliance will ensure that it gives you the very best performance and a long, economical service life.

This manual contains the information needed to properly install this appliance, and to use and care for the appliance in a manner which will ensure its optimum performance.

SPECIFICATIONS

MODEL	VOLTS	WATTS			AMPS PE R LEG 3 ϕ			AMPS 1 ϕ	POWER SUPPLY CORD
		OVEN	HOT- PLATES	TOTAL	L1	L2	L3		
OC-1	208 1 ϕ	5000	NONE	5000				24.0	NEMA 6-30P
	240 1 ϕ	5600	NONE	5600				24.0	
OC-4HS OPEN COIL	208 3 ϕ	5000	8000	13000	36.8	36.8	34.8		NEMA 15-60P
	240 3 ϕ	5600	10400	16000	39.2	39.2	37.4		
	480 3 ϕ	5600	10400	16000	19.7	19.7	18.3		NONE / HARDWIRE
OC-4HF SOLID PLATE	208 3 ϕ	5000	6000	11000	32.7	32.7	26.2		NEMA 15-60P
	240 3 ϕ	5600	8000	13600	34.0	34.0	30.1		

DIMENSIONS

HEIGHT	WIDTH	DEPTH	DOOR SWING	REQUIRED CLEARANCES
30-1/4" (768mm) plus 6" (152mm) legs or casters	30-1/4" (768mm)	26-1/4" (641mm) plus 1-13/16" (46mm) handle	21" (635mm) radius	Bottom 6" (152mm) Front 21" (533mm) Top n/a Back 3" (76mm) Sides 3" (76mm)

NOTE: refer to appropriate General Layout Data sheet for complete specifications and dimensions.

FEATURES & OPERATING CONTROLS

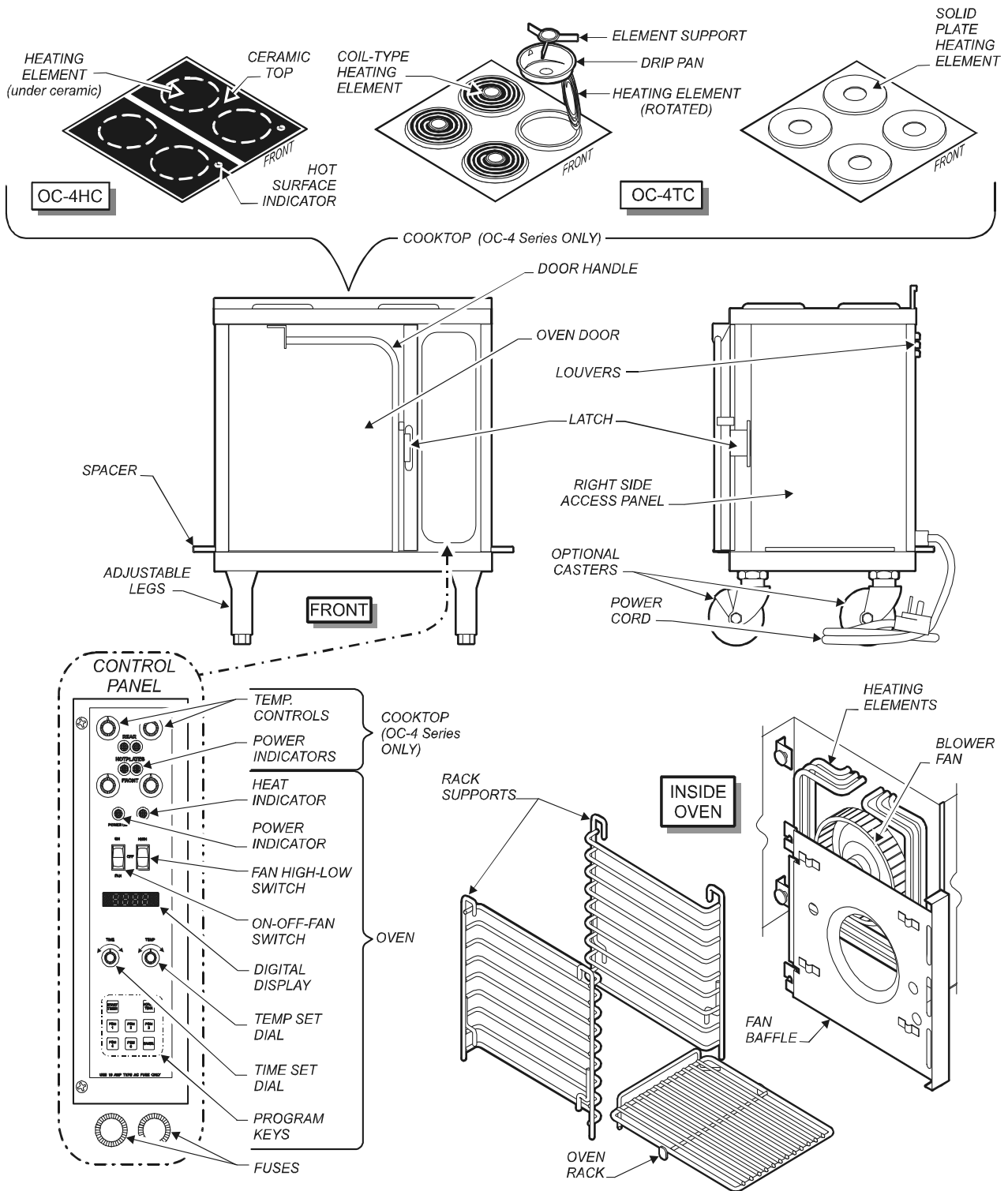

Fig. 1 Features & Operating Controls

M273 p/n 2M-303875 Owners Manual OC-1 & OC-4 Half-Size Convection Ovens

FEATURES & OPERATING CONTROLS (continued)

FEATURES & OPERATING CONTROLS

COOKTOP CONTROLS (OC-4 Series ONLY)

1. Four sections are controlled by individual infinite switch controls.
2. Associated power indicator will glow any time section is ON.

OVEN POWER SWITCH (ON-OFF-FAN):

1. ON position (with door closed). POWER ON indicator will glow, blower fan will come on and unit will start to heat.
NOTE: In the ON position, if the door is opened, blower fan is turned off and heating elements are de-energized.
2. FAN position. Blower fan will run (regardless of door position). Heating elements are not energized.
SUGGESTION: For faster cool-down, prop door open and place power switch in FAN position.
3. OFF position shuts off power and blower fan.

OVEN FAN SPEED SWITCH (HIGH-LOW):

1. HIGH for normal operation.
2. LOW for foods sensitive to air currents.
3. OFF position shuts off blower fan

TIME ADJUSTMENT KNOB:

Used to program menu times (See PROGRAM COOK MODE, page 7.)

TEMP ADJUSTMENT KNOB

Used to program menu temperatures (See PROGRAM COOK MODE, page 7.)

DIGITAL DISPLAY

1. Displays set temperature or set time.
2. Displays temperature inside oven when ACTUAL TEMP key is pressed.
3. Displays set time and temperature of individual menu items when the associated PGM key is pressed
4. Displays time and temperature settings in programming mode.

START TIMER KEY

Begins a cook cycle.

PROGRAM KEYS

Five different pre-set time/temperature combinations for preparing different menu items.

CANCEL KEY

1. Press at any time to cancel a cook cycle.
2. Press at the end of a cook cycle to silence the audible alarm.

OVEN RACKS:

1. Five oven racks are provided with the oven.
2. Racks may be inserted into any available slot in the rack supports.
3. Always cook on a rack for proper convection air circulation.
4. Racks are designed to hold half-size (13" x 18") bun pans.



CAUTION: HOT SURFACE

Exposed surfaces can be hot to the touch and may cause burns.

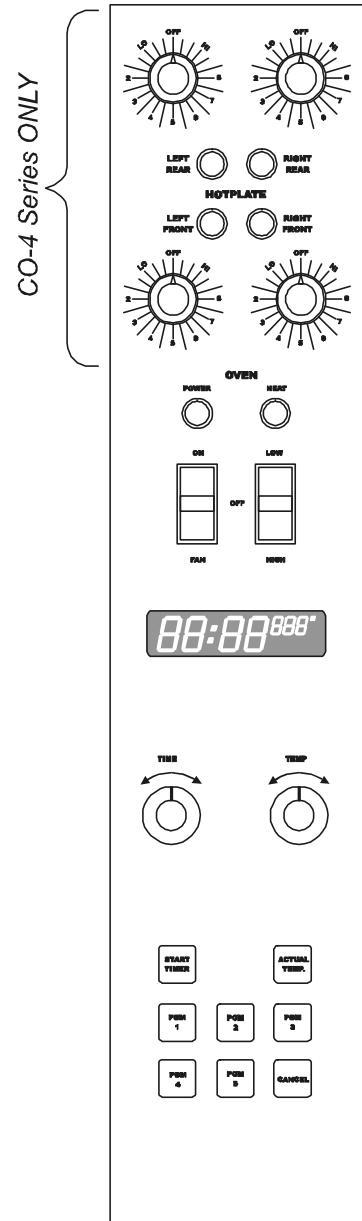

Fig. 2 Control Panel

PRECAUTIONS AND GENERAL INFORMATION



WARNING: ELECTRIC SHOCK HAZARD

All servicing requiring access to non-insulated electrical components must be performed by a factory authorized technician.
DO NOT open any access panel which requires the use of tools. Failure to follow this warning can result in severe electrical shock.



CAUTION: RISK OF DAMAGE

DO NOT connect or energize this appliance until all installation instructions are read and followed. Damage to the appliance will result if these instructions are not followed.



CAUTION: HOT SURFACE

Exposed surfaces can be hot to the touch and may cause burns.

This appliance is intended for use in commercial establishments only.

This appliance is intended to prepare food for human consumption. No other use is recommended or authorized by the manufacturer or its agents.

Operators of this appliance must be familiar with the appliance use, limitations and associated restrictions. Operating instructions must be read and understood by all persons using or installing this appliance.

Cleanliness of this appliance is essential to good sanitation. Read and follow all included cleaning instructions and schedules to ensure the safety of the food product.

Disconnect this appliance from electrical power before performing any maintenance or servicing.

DO NOT submerge this appliance in water. This appliance is not jet stream approved. Do not direct water jet or steam jet at this appliance, or at any control panel or wiring. Do not splash or pour water on, in or over any controls, control panel or wiring. Do not wash floor around this appliance with water or steam jet.

Exposed surfaces of this appliance can be hot to the touch and may cause burns.

Do not operate this appliance if the control panel is damaged. Do not operate this appliance if the keypad section of the control panel is torn or broken. Call your Authorized Wells Service Agent for service.

The technical content of this manual, including any wiring diagrams, schematics, parts breakdown illustrations and/or adjustment procedures, is intended for use by qualified technical personnel.

Any procedure which requires the use of tools must be performed by a qualified technician.

This manual is considered to be a permanent part of the appliance. This manual and all supplied instructions, diagrams, schematics, parts breakdown illustrations, notices and labels must remain with the appliance if it is sold or moved to another location.

This appliance is made in the USA. Unless otherwise noted, this appliance has American sizes on all hardware.

AGENCY LISTING INFORMATION



STD 4



E6070



E6070

This appliance conforms to NSF Standard 4 for sanitation only if installed in accordance with the supplied *Installation Instructions* and maintained according to the instructions in this manual.

This appliance is  Listed under UL File E6070.

This appliance is  Listed under UL File E6070 for 208V and 240V models only.

UNPACKING & INSPECTION

Carefully remove the appliance from the carton. Remove all protective plastic film, packing materials and accessories from the Appliance before connecting electrical power or otherwise performing any installation procedure.

Carefully read all instructions in this manual and the *Installation Instruction Sheet* packed with the appliance before starting any installation.

Read and understand all labels and diagrams attached to the appliance.

Carefully account for all components and accessories before discarding packing materials. Store all accessories in a convenient place for later use.

COMPONENTS

- 3 ea. OVEN RACKS
- 2 ea. RACK SUPPORTS
- 1 ea. FAN BAFFLE
- 1 ea. VENT DUCT ASSEMBLY

ACCESSORIES

- 1 ea. LITERATURE PACKAGE

OPTIONAL ACCESSORIES

- 22882 Stacking and Venting Kit

SERVICE TECHNICIAN INSTALLATION NOTES

1. Installation and start up should be performed by an authorized installation company. Installer must record installation particulars on the *CUSTOMER SERVICE DATA* form on page 15 of this manual.
2. Verify that this equipment installation is in compliance with the specifications listed in this manual and with local code requirements.

NOTE: DO NOT discard the carton or other packing materials until you have inspected the appliance for hidden damage and tested it for proper operation. Refer to *SHIPPING DAMAGE CLAIM PROCEDURE* on the inside front cover of this manual.



WARNING: RISK OF INJURY

Installation procedures must be performed by a qualified technician with full knowledge of all applicable electrical and plumbing codes. Failure can result in personal injury and property damage.

IMPORTANT:
It is the **RESPONSIBILITY OF THE INSTALLER** to check with the **AUTHORITY HAVING JURISDICTION**, in order to verify compliance with local codes and ordinances for **THIS SPECIFIC EQUIPMENT INSTALLATION**.

INSTALLATION (continued)



WARNING: **ELECTRIC** **SHOCK HAZARD**

All servicing requiring access to non-insulated electrical components must be performed by a factory authorized technician.

DO NOT open any access panel which requires the use of tools. Failure to follow this warning can result in severe electrical shock.

NOTE: Oven is shipped with biscuit baking adapter plate attached to rear panel. If oven is used exclusively for bread products (bread, pies, etc.), DO NOT remove adapter.

If oven is used for proteins, remove adapter and install external vent. Protein requires additional venting to decrease release of cooking vapors when opening the door.

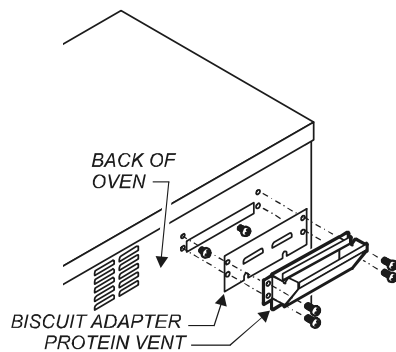

Fig. 3 Vent Duct Installation

EQUIPMENT SET-UP

1. IF CONVECTION OVEN IS TO BE USED FOR PROTEINS, INSTALL EXTERNAL DUCT
 - a. Remove two screws at each end of adapter plate on back of oven.
 - b. Loosen two screws at bottom of adapter plate. Remove adapter plate.
 - c. Slide bottom flange of vent duct over the two loosened screws.
 - d. Install four and tighten screws at ends of vent duct, then tighten bottom screws.
2. CURB or COUNTER MOUNTING
 - a. Setup the appliance only on a firm, level, non-combustible surface. Verify local codes for requirements. Concrete, tile, terrazzo or metal surfaces are recommended. Metal over combustible material may not meet code for non-combustible surfaces.
 - b. Appliance is approved for installation with zero clearance at bottom.
 - c. Recommend at least 3" clearance on sides and back to allow adequate air flow.
3. INSTALLING LEGS
 - a. Install adjustable legs, one on each corner of the appliance, in the holes provided.
 - b. Set up the appliance only on a firm, level, non-combustible surface. Verify local codes for requirements. Concrete, tile, terrazzo or metal surfaces are recommended. Metal over combustible material may not meet code for non-combustible surfaces.
 - c. **LEVELING:** Verify that the appliance sits firmly ON ALL FOUR LEGS. With a spirit level, check that the appliance is level front-to-back and side-to-side.
4. INSTALLING OPTIONAL CASTERS
 - a. Install casters, one on each corner of the appliance, in the holes provided. Locking casters must be installed on the FRONT of the appliance.
 - b. Set up the appliance only on a firm, level, non-combustible surface. Verify local codes for requirements. Concrete, tile, terrazzo or metal surfaces are recommended. Metal over combustible material may not meet code for non-combustible surfaces.
 - c. **LEVELING:** Verify that the appliance sits firmly on all four casters when in its normal operational position. With a spirit level, check that the appliance is level front-to-back and side-to-side.



DANGER: ELECTRICAL SHOCK HAZARD

ELECTRICAL CONNECTIONS MUST BE MADE BY A LICENSED ELECTRICIAN

Electrical shock will cause death or serious injury.

ELECTRICAL INSTALLATION

Refer to the nameplate on the front of the appliance.

- Verify the ELECTRICAL SERVICE POWER.
- Voltage and phase must match the nameplate specifications, and available electrical service amperage must meet or exceed the specifications listed on page 1.

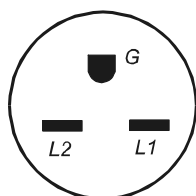

NEMA 6-30R

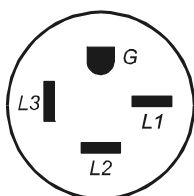

NEMA 15-60R

Fig. 4 Receptacle Configuration (not to scale)

208V and 240V OC-1 ovens are equipped with a NEMA 6-30P plug, which must be plugged into a matching NEMA 6-30R receptacle.

208V and 240V OC-4TC and OC-4HC ovens are equipped with a NEMA 15-60P plug, which must be plugged into a matching NEMA 15-60R receptacle.

The ground lug of the receptacle must be connected to a suitable building ground.

480V OC-4TC ovens must be wired directly to a 30 amp, 3 ϕ circuit breaker.

IMPORTANT:

OC-4 series ovens are shipped from the factory wired for 3-phase (3 ϕ) electrical service. OC-4 series ovens are not approved for 1 ϕ operation. Conversion of this appliance to single-phase operation will void the warranty.

IMPORTANT: Some jurisdictions require an electrical disconnect in close proximity to the appliance. It is the responsibility of the installer to meet this requirement.

PREPARATION

Prior to your first use of this appliance, clean the entire appliance by wiping all surfaces with a soft clean cloth moistened with warm clean water and mild detergent. Rinse by wiping with clean water. Wipe dry with a soft clean cloth.



CAUTION: RISK OF DAMAGE

DO NOT connect or energize this appliance until all installation instructions are read and followed. Damage to the appliance will result if these instructions are not followed.



CAUTION: ELECTRICAL SHOCK HAZARD

The ground prong of the power cord is part of a system designed to protect you from electric shock in the event of internal damage to the NEVER CUT OFF THE GROUND PRONG (large round prong). NEVER TWIST A PRONG TO FIT AN EXISTING RECEPTACLE. Contact a licensed electrician to install an electrical receptacle appropriate to the voltage and amperage requirements of the appliance. The ground lug of 480V appliances must be connected to a suitable building ground.

IMPORTANT:

Damage due to being connected to the wrong voltage or phase is NOT covered by warranty.

OPERATION



CAUTION: HOT SURFACE

Exposed surfaces can be hot to the touch and may cause burns.

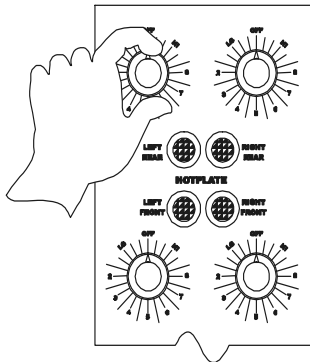

Fig. 5 Set Cooktop Temp.

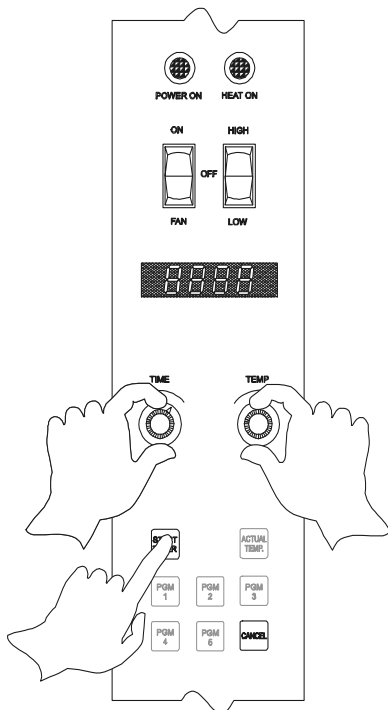

Fig. 6 Manual Cook Mode

MANUAL COOK MODE

On ovens equipped with optional casters, be sure casters are locked before turning power switch ON.

Configure oven racks as appropriate. Close the oven door.

Cooktop has four individually controllable hotplate sections. Turn appropriate hotplate TEMP knob to energize hotplate:

1. There are an infinite number of settings between LO and HI.
2. HI is a continuous ON position.
3. Corresponding indicator will glow when hotplate is ON.

Press oven power switch to ON. POWER ON indicator will glow.

Press fan switch to HIGH or LOW as required.

Rotate TEMP knob to the desired cooking temperature:

1. Range is 100°F to 500°F.
2. Turn clockwise to increase temperature, or counter-clockwise to decrease set temperature in 5°F intervals.
3. Digital display will show the set temperature, and will flash until the set temperature is reached.
4. Elements are energized as soon as the set temperature exceeds the actual temperature. HEAT ON indicator will glow.
SUGGESTION: The oven may be turned OFF without placing the power switch in the OFF position by rotating the TEMP knob counter-clockwise until the display shows zero degrees.

Rotate the TIME knob to the desired cooking time:

1. Range is 5 seconds (00:05) to 12 hours (12:00).
2. Turn clockwise to increase time, or counter-clockwise to decrease time in 5 second intervals.
3. Time display digits and colon will flash until timer is started.

When the HEAT ON indicator goes out, oven is up to temperature. Load product and close door.

Press START TIMER key.

1. Time display digits will stop flashing;
2. Time display colon will continue flashing for the duration of the timed cycle.
3. At the end of the timed cycle, an audible alarm will sound. Press CANCEL key to silence the audible alarm.

PROGRAM COOK MODE

Five programmable (PGM) keys are provided to allow presetting times and temperatures for commonly cooked menu items:

1. Press and hold the appropriate PGM key and turn the TEMP knob to the desired set temperature.
2. Continue to press and hold the appropriate PGM key and turn the TIME knob to the desired cook time.
3. When the PGM key is released, the current temperature and time settings are stored in memory.
4. The program for any PGM key may be displayed for momentarily pressing that PGM key.

On ovens equipped with optional casters, be sure casters are locked before turning power switch ON.

Configure oven racks as appropriate. Close the oven door.

Press power switch to ON. POWER ON indicator will glow.

Press fan switch to HIGH or LOW as required.

Preheat the oven in the manual cook mode.

Start a cook cycle by pressing the appropriate PGM key and START TIMER key:

1. Program keys and TEMP and TIME knobs are disabled during the cooking cycle to prevent accidental re-programming.
2. The actual oven temperature may be recalled by pressing the ACTUAL TEMP key.
3. At the end of the timed cycle, an audible alarm will sound. Press CANCEL key to silence the audible alarm.

TEMPERATURE OFFSET MODE

A user preference offset mode is provided should the displayed temperature seem too hot or cold. This mode is used to adjust the oven controlling temperature by plus or minus 35°F, in 5°F increments. This adjustment affects the entire cooking range:

1. Rotate the TIME knob to set the time digits to 00:00
2. Rotate the TEMP knob to adjust the set temperature between 400°F and 500°F.
3. Press and hold the START TIMER key for 5 seconds.
4. Turn either rotary knob until the desired offset is displayed.
5. Press the ACTUAL TEMP key to exit, and to store the offset in memory.



**CAUTION:
HOT SURFACE**

Exposed surfaces can be hot to the touch and may cause burns.

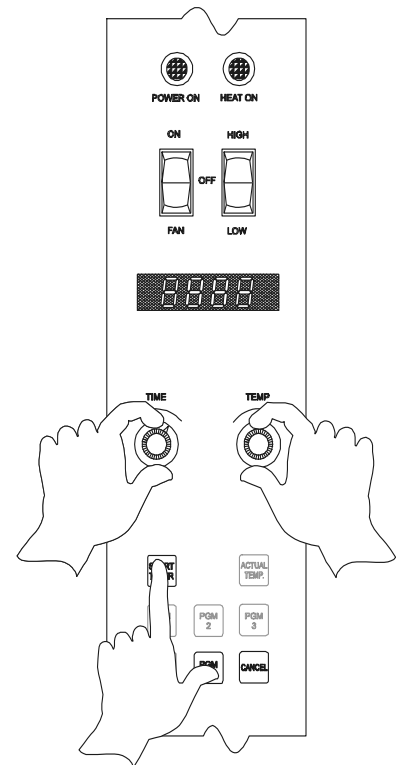

Fig. 7 Program Cook Mode

SUGGESTED TIMES & TEMPERATURES FOR BAKING AND ROASTING

PRODUCT	TEMP °F	TIME (MINUTES)	NO. OF RACKS
BREAD PRODUCTS			
Hamburger Rolls	300	15	5
Bread— 1 pound loaves	325	34	3 (12 loaves)
Rolls	300	16	5 (60 rolls)
Baking Soda Biscuits	400	7	3
Pizza	450	7	3
PASTRIES			
Sheet Cake (2-1/2 lbs per pan)	300	17	5
Frozen Fruit Pies (46 oz.)	350	50	5 (10 pies)
Frozen Fruit Pies (26 oz— 8" dia.)	350	40	5 (15 pies)
Sugar Cookies	300	15	5
Danish Rolls	350	12	5
Fruit Cakes	275	75	3
Cake— 1 pound	300	19	5 (10 cakes)
FISH			
Fish Sticks	350	15	5
Lobster Tails	450	9	5
Halibut Steaks (Frozen 5 oz.)	350	20	5
Baked Shrimp (Stuffed)	400	7	5
FOWL			
Turkey, Rolled (18 lb. Rolls)	310	225 (3-3/4 hrs)	1
Chicken (2-1/2 lb. Quartered)	350	30— 35	5
Chicken (Breasts)	350	30	5
OTHER			
Melted Cheese Sandwich	400	8	5
Idaho Potatoes (120)	450	40	5
Beef Pot Pies	400	30— 35	5
Macaroni & Cheese	350	30	5
Turkey Pot Pies	400	30— 35	5
TV Dinners	450	25	5

NOTE: These cooking times and temperatures are suggestions only. Your own experience with your equipment and menu items will be your best guide.

NOTE: HIGH fan speed provides the fastest cooking times. Use LOW fan speed for menu items that are sensitive to air currents (e.g. meringues and soufflés).

CLEANING INSTRUCTIONS

PREPARATION	Allow oven to cool to 150°F or less
FREQUENCY	Daily
TOOLS	Fiber Brush, Plastic Scouring Pad, Plastic Scraper Mild Detergent, Conventional Oven Cleaner, Non-Abrasive Cleanser Clean Soft Cloth / Sponge Solution: 4 parts vinegar to 10 parts warm water

CLEANING

1. Turn POWER SWITCH to *FAN*. With the door held open, allow the oven to cool. When the oven interior has cooled to 150°F or less, turn the POWER SWITCH to *OFF*.
2. Remove racks and rack supports. Remove fan baffle.
3. Brush the fan wheel and wipe it with a moist cloth. Sponge out all loose particles.
4. Scrub entire interior of convection oven with a plastic scouring pad and non-abrasive cleanser.
5. For baked-on food spills, sparingly use a conventional oven cleaner. Close the oven door, place the ON/OFF/FAN switch in the OFF position. Let stand for 10 minutes. Carefully wipe all cleaner and food residue from all interior surfaces. Wipe the area with vinegar solution to neutralize the oven cleaner.
6. Wipe down the entire interior using a clean cloth or sponge moistened with hot water and a mild detergent. Rinse by wiping with a cloth or sponge moistened with clean water.
IMPORTANT: Always wipe or rub in the direction of the polish lines or grain of the metal.
7. Clean oven racks and rack supports in a sink or dishwasher.
8. Reinstall the fan baffle, paying particular attention that the lip on the right side of the fan baffle is fully seated in the slot in the edge of the oven cavity. Reinstall rack supports and racks.
9. Turn power switch to *FAN*. Verify that fan runs smoothly and does not contact fan baffle. Turn power switch to *OFF*. Reposition fan baffle if necessary.
10. Replace rack supports and oven racks. Leave the door open overnight.

Cleaning Instructions continued on page 12.

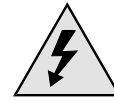

CAUTION:
ELECTRIC SHOCK
HAZARD

Disconnect appliance from electric power before cleaning.



CAUTION:
BURN HAZARD

Allow appliance to cool completely before cleaning. Do not attempt to clean the oven until it has cooled to 150°F or less. It can burn you. Hand protection is required.



CAUTION:
CUT HAZARD

FAN BLADES ARE SHARP. Use due care when cleaning and/or wiping.

IMPORTANT:

Take care to avoid damage to fan blades when reinstalling fan baffle.

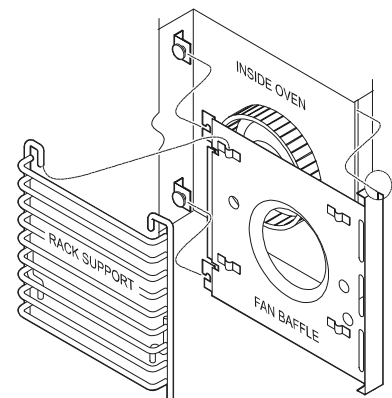

Fig. 8 Baffle & Rack Support

CLEANING INSTRUCTIONS (continued)



IMPORTANT: DO NOT spill or pour water into controls, control panel or wiring.

Damage to internal components from water damage is **not** covered by warranty.

IMPORTANT: DO NOT use metal implements or steel wool to clean coil-type elements or solid plate elements.

IMPORTANT: Use only the provided scraper to remove baked-on food debris from the ceramic cooktop. DO NOT use metal implements or steel wool.

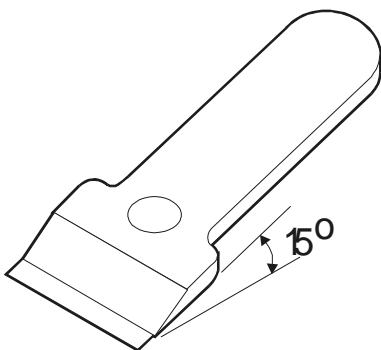

Fig. 9 Razor Scraper

11. Clean cooktop:

For coil-type elements:

- Rotate elements up. Remove drip pans and element supports.
- Wash drip pans and element supports with warm water and mild detergent. A plastic scouring pad may be used to remove baked-on food particles.
- Rinse with clean water and allow to air dry before reinstalling drip pans and element supports.
- Gently lower elements into place.

For solid plate elements:

- Note: Solid plate elements are not removable. Wash with a cloth or sponge moistened with warm water and mild detergent. A plastic scouring pad may be used to remove baked-on food particles.
- Rinse by wiping with a cloth or sponge moistened with clean water.

For ceramic cooktop:

- Wash with a cloth or sponge moistened with warm water and mild detergent.
- The supplied razor scraper must be used to remove baked-on food particles. Hold the blade at 15° to the surface. Avoid scratching the ceramic surface.
- Restore and protect the surface by wiping with cleaning crème for ceramic hotplates.

- Wipe down exterior of the oven using a soft cloth moistened with clean water and a mild detergent. A plastic scouring pad may be used to removed baked-on food debris. Rinse by wiping with a cloth or sponge moistened with clean water.

IMPORTANT: Always wipe or rub in the direction of the polish lines or grain of the metal.

PROCEDURE IS COMPLETE

TROUBLESHOOTING SUGGESTIONS

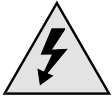

CAUTION: ELECTRICAL SHOCK HAZARD

Removal of any cabinet panel will result in exposed electrical circuits. Any procedure requiring the removal of any cabinet panel must be performed by a qualified technician only.

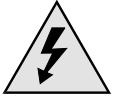

CAUTION: ELECTRICAL SHOCK HAZARD

Fuse replacement may expose dangerous voltages. Fuse replacement must be performed by a qualified technician.

SYMPTOM	POSSIBLE CAUSE	SUGGESTED REMEDY
No power to appliance	Circuit breaker off or tripped	Reset circuit breaker
	Power cord unplugged or damaged	Check power cord Plug in or repair as required
	Fuse blown or loose	Check power fuses. If blown, correct problem and replace fuses
Oven will not heat	Power switch turned to OFF or FAN	Turn power switch ON
	Temperature control not set	Set to desired temperature
	Oven door not closed	Be sure door is closed and latched
	Hi-limit control tripped on excessive oven temperature	Allow oven to cool Hi-limit will reset
	Damaged controller	Contact Authorized Wells Service Agency for repairs
Blower fan will not run	Fan switch OFF	Turn fan switch to HIGH or LOW
	Damage to internal components	Contact Authorized Wells Service Agency for repairs
Door pops open during cook cycle	Latch out of adjustment	Adjust latch
Section of cooktop won't heat or not hot enough	Control not turned ON	Set control
	Damage to internal component	Contact Authorized Wells Service Agency for repairs

NOTE: There are no user serviceable components in the appliance. In all cases of damage or component malfunction, contact your Authorized Wells Service Agency for repairs.

PREVENTATIVE MAINTENANCE



CAUTION: BURN HAZARD

Allow appliance to cool completely before adjusting.

HINGE ADJUSTMENT

PRECAUTIONS: None

FREQUENCY: Monthly, at a Minimum; or, As Needed

TOOLS: Phillips (+) Screwdriver
7/16" Nut Driver
7/8" and 1-1/8" Wrenches

THE FOLLOWING PROCEDURE IS TO BE PERFORMED BY QUALIFIED PERSONNEL ONLY

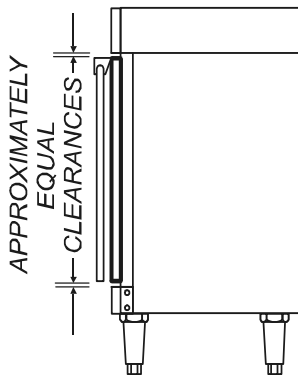
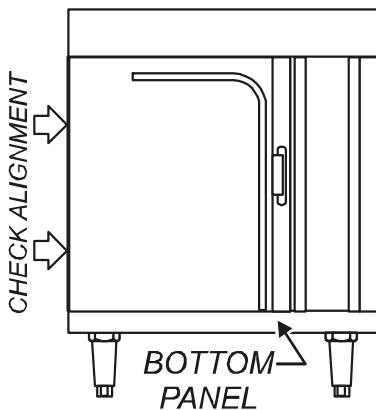

Hinge Adjustment

1. Remove bottom panel to access pivot.

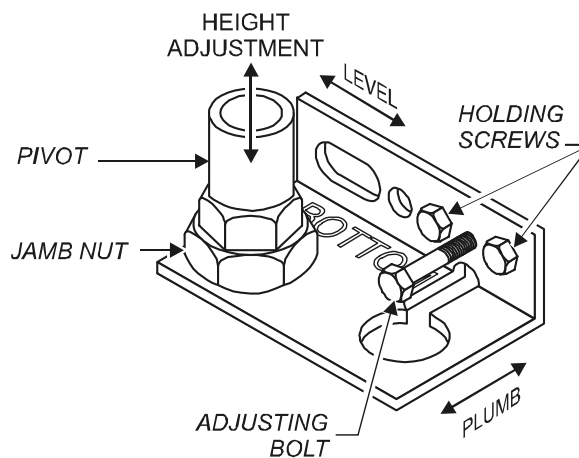

2. Gap between top of door and frame, and between bottom of door and frame must be approximately equal

Adjust height of door by loosening jamb nut, then turning pivot on its screw mounting. Clockwise lowers the door height. Re-tighten jamb nut.

3. Gap between left side of door and frame must be the same from top to bottom

Adjust door for plumb by loosening holding screws. Turn adjusting bolt to increase or decrease gap at bottom. Clockwise increases gap. Re-tighten holding screws.

4. Gap between top of door and frame must be the same from side to side

Adjust door for level by loosening holding screws, then raising or lowering latch-end of door until it is level. Re-tighten holding screws.

5. Reinstall bottom panel.

Procedure is complete



**CAUTION:
BURN HAZARD**

Allow appliance to cool completely before adjusting.

HINGE ADJUSTMENT

- PRECAUTIONS:** None
- FREQUENCY:** Monthly, at a Minimum; or, As Needed
- TOOLS:** Phillips (+) Screwdriver
7/16" Nut Driver
7/8" and 1-1/8" Wrenches

THE FOLLOWING PROCEDURE IS TO BE PERFORMED BY QUALIFIED PERSONNEL ONLY

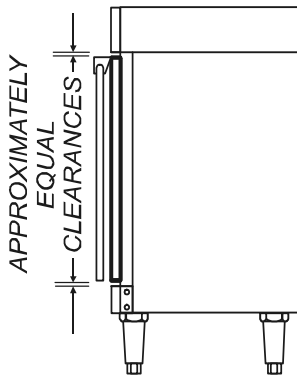
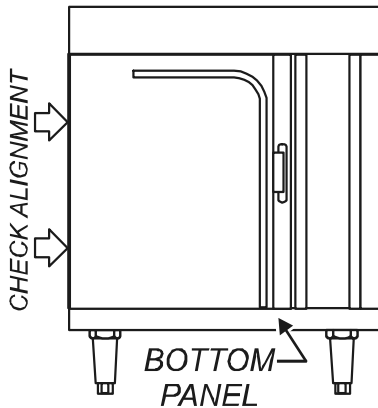

Hinge Adjustment

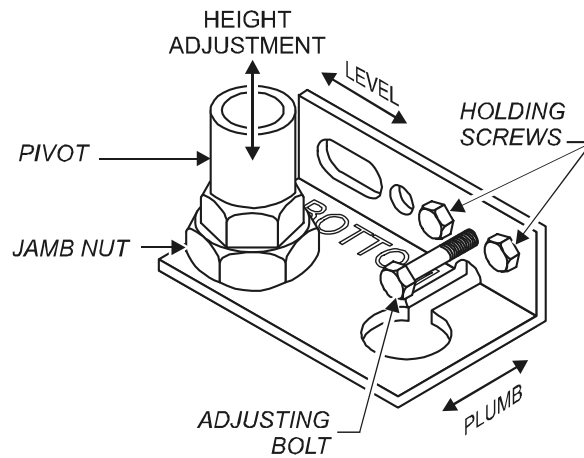

1. Remove bottom panel to access pivot.
 2. Gap between top of door and frame , and between bottom of door and frame must be approximately equal
Adjust height of door by loosening jamb nut, then turning pivot on its screw mounting. Clockwise lowers the door height. Re-tighten jamb nut .
 3. Gap between left side of door and frame must be the same from top to bottom
Adjust door for plumb by loosening holding screws. Turn adjusting bolt to increase or decrease gap at bottom. Clockwise increases gap. Re-tighten holding screws.
 4. Gap between top of door and frame must be the same from side to side
Adjust door for level by loosening holding screws, then raising or lowering latch-end of door until it is level. Re-tighten holding screws.
 5. Reinstall bottom panel.
- Procedure is complete

EXPLODED VIEW & PARTS LIST

OC-1 CABINET COMPONENTS

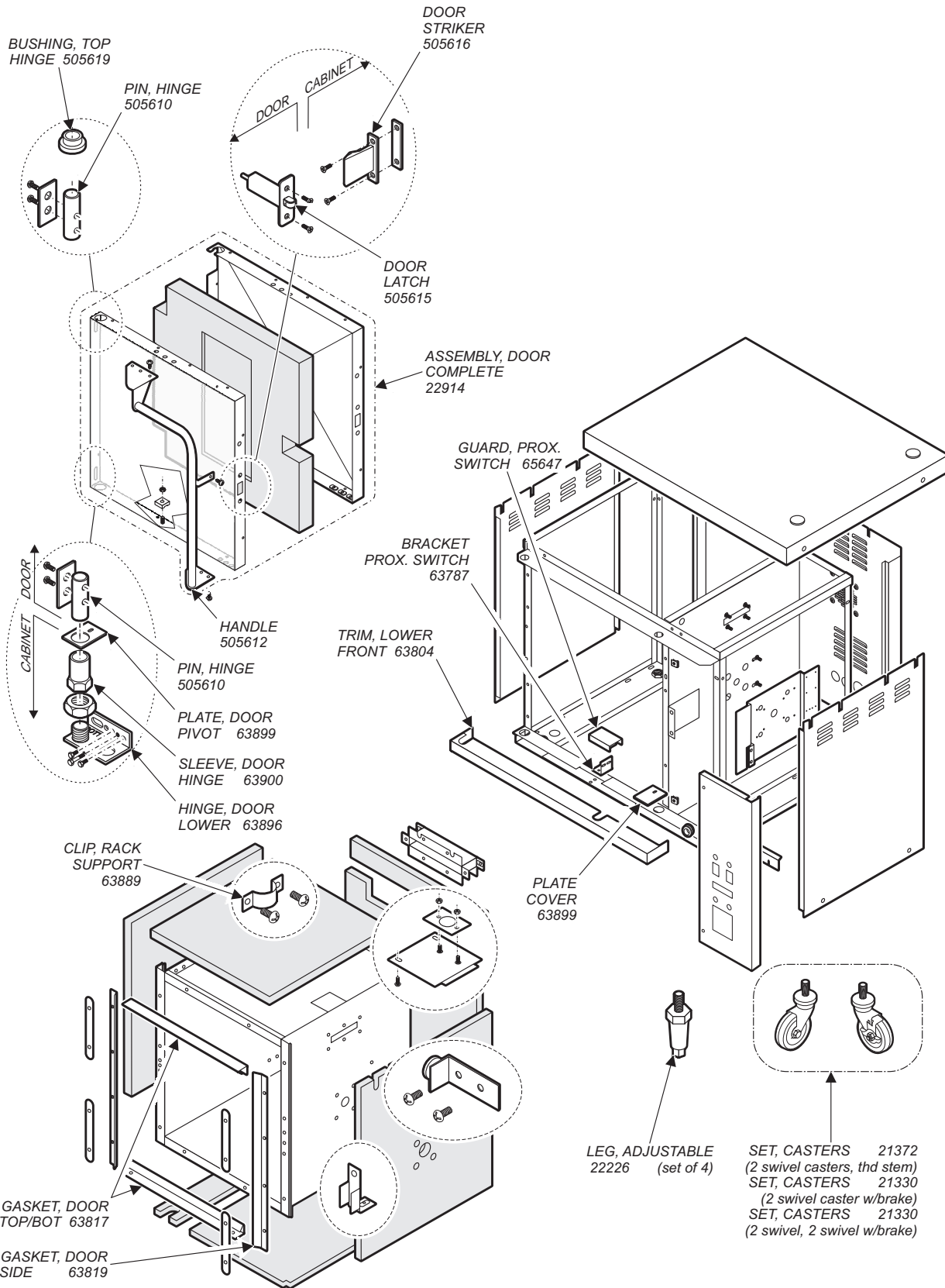

M273 p/n 2M-303875 Owners Manual OC-1 & OC-4 Half-Size Convection Ovens

EXPLODED VIEW & PARTS LIST

OC-1 ELECTRICAL COMPONENTS

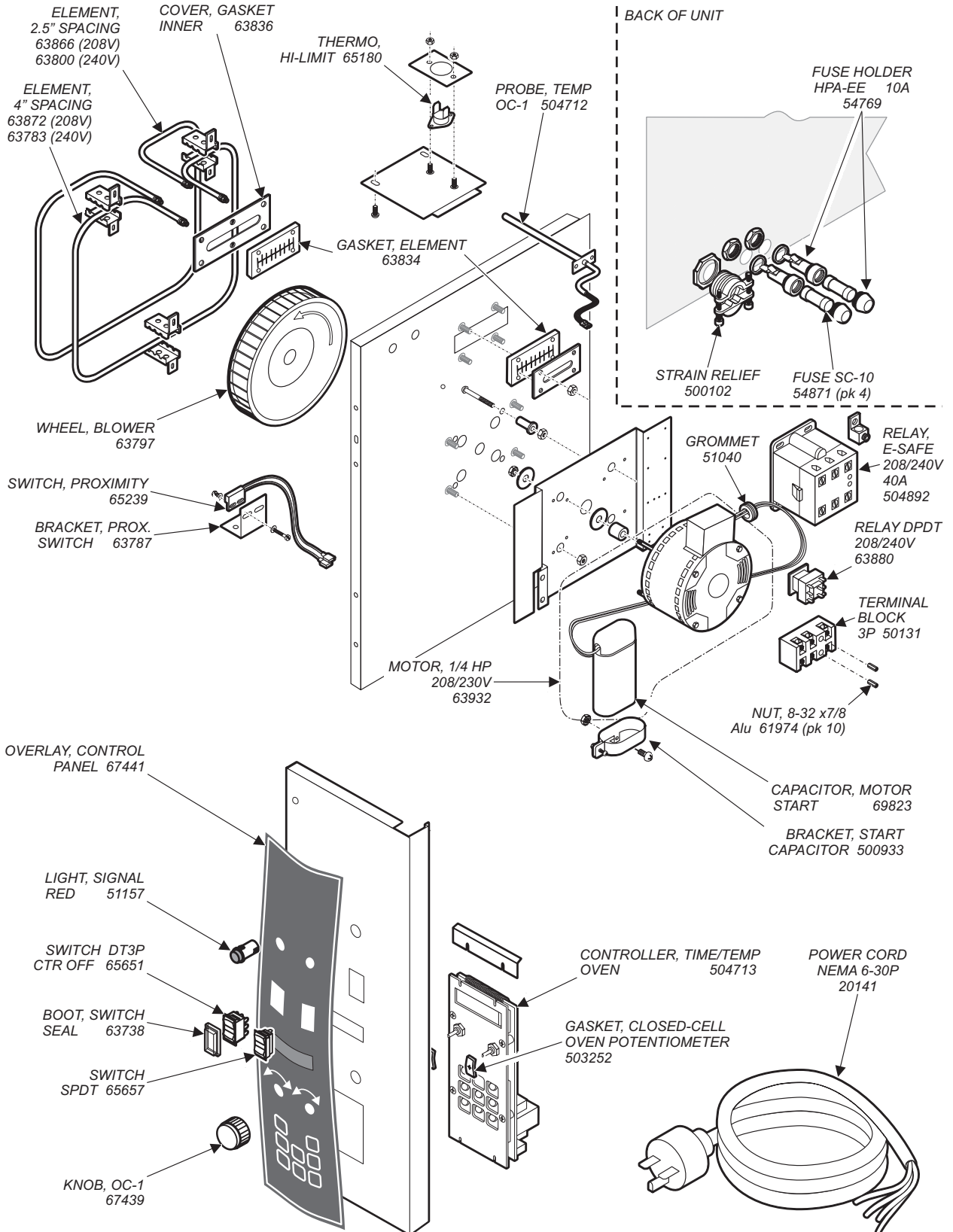

M273 p/n 2M-303875 Owners Manual OC-1 & OC-4 Half-Size Convection Ovens

EXPLODED VIEW & PARTS LIST

OC-4 CABINET COMPONENTS

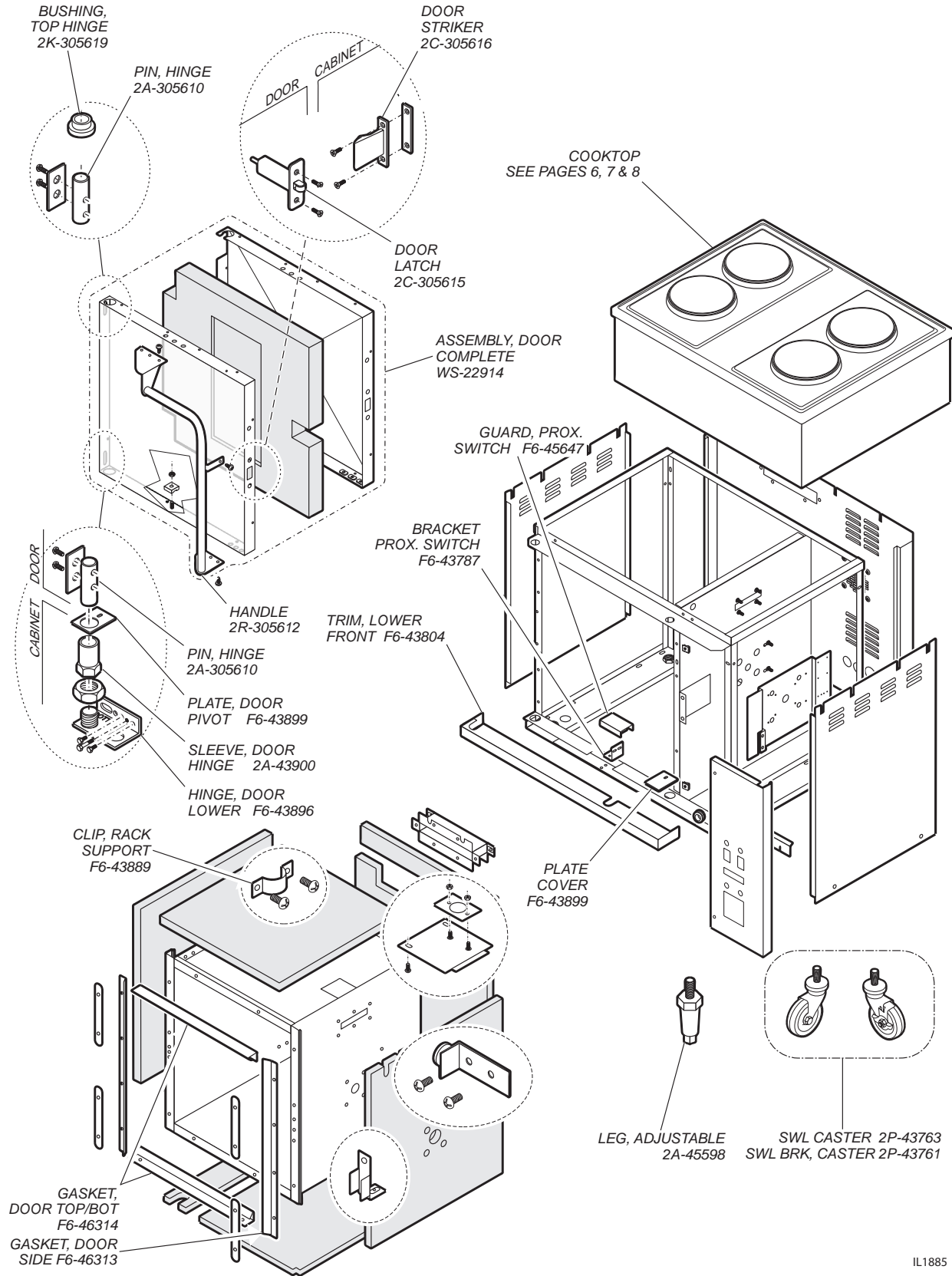

M273 p/n 2M-303875 Owners Manual OC-1 & OC-4 Half-Size Convection Ovens

IL1885

EXPLODED VIEW & PARTS LIST

OC-4 ELECTRICAL COMPONENTS

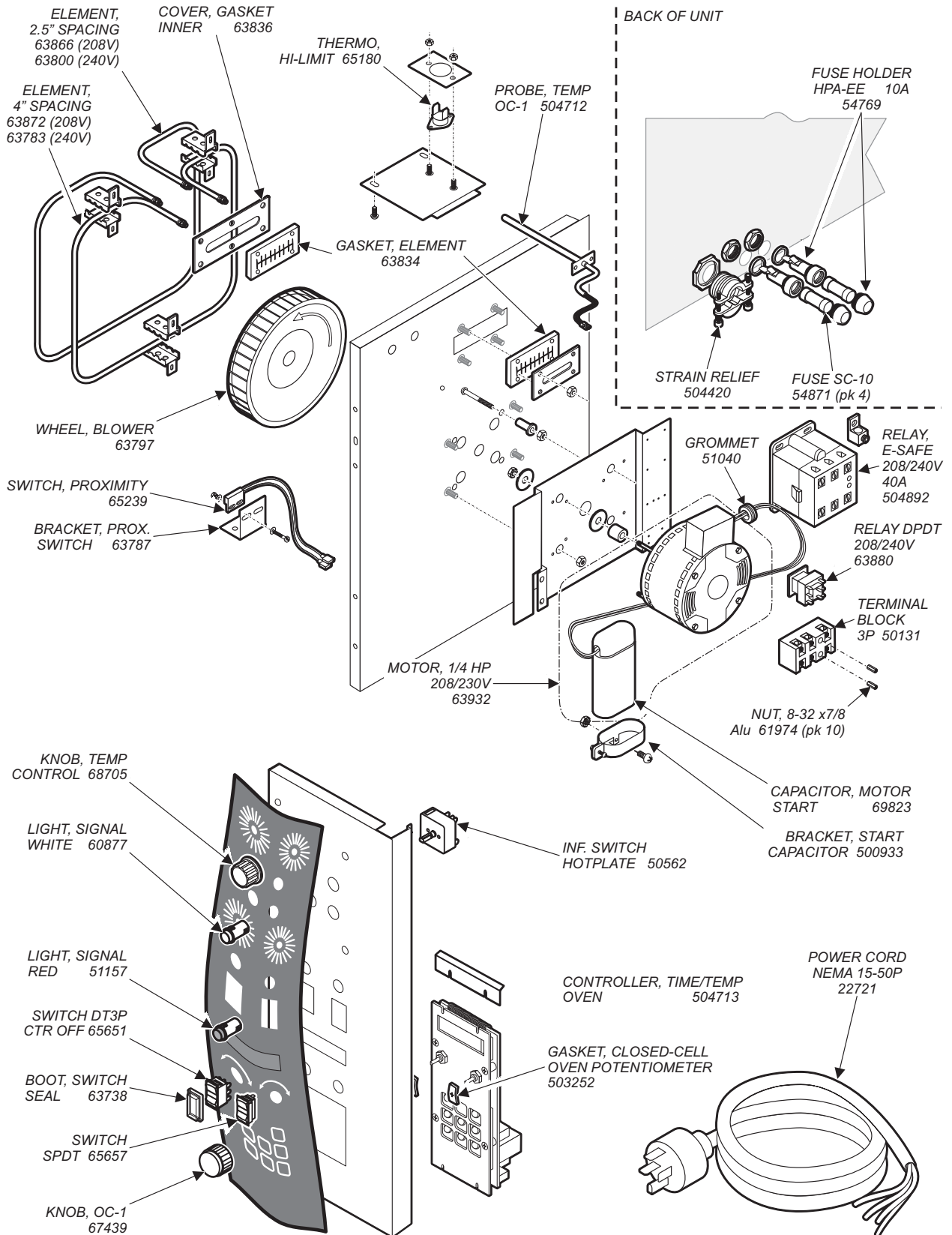

M273 p/n 2M-303875 Owners Manual OC-1 & OC-4 Half-Size Convection Ovens

EXPLODED VIEW & PARTS LIST

OC-4 TC COOKTOP COMPONENTS

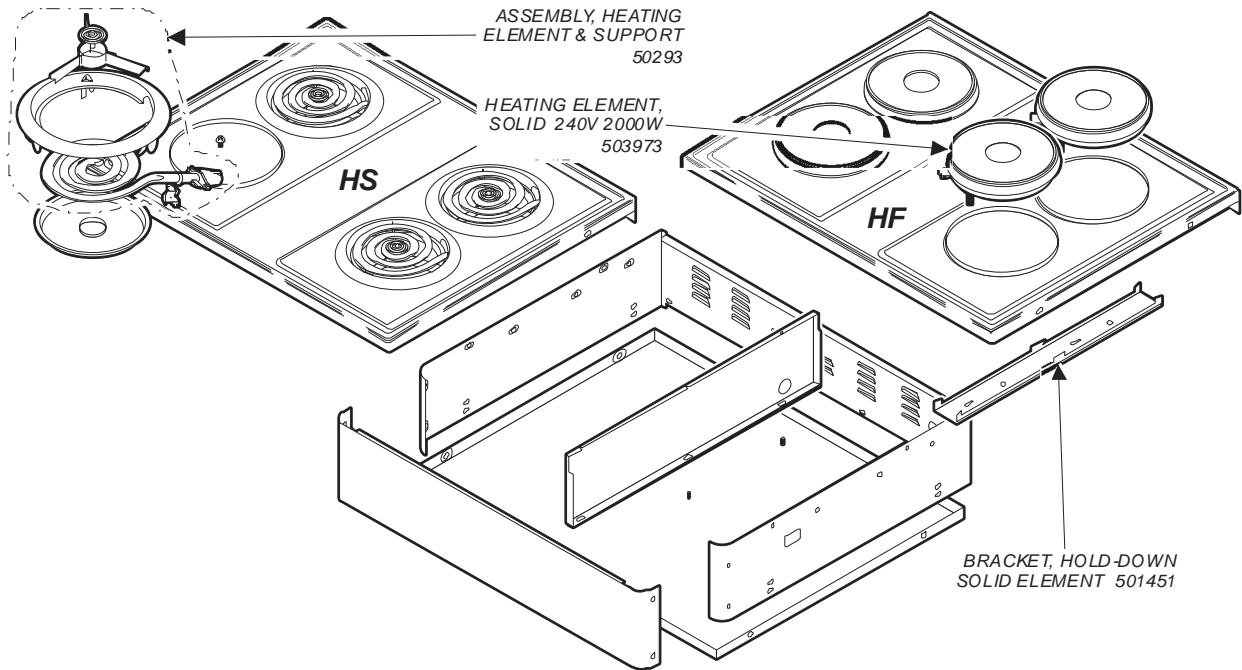

OC-1 & OC-4 REMOVABLE COMPONENTS

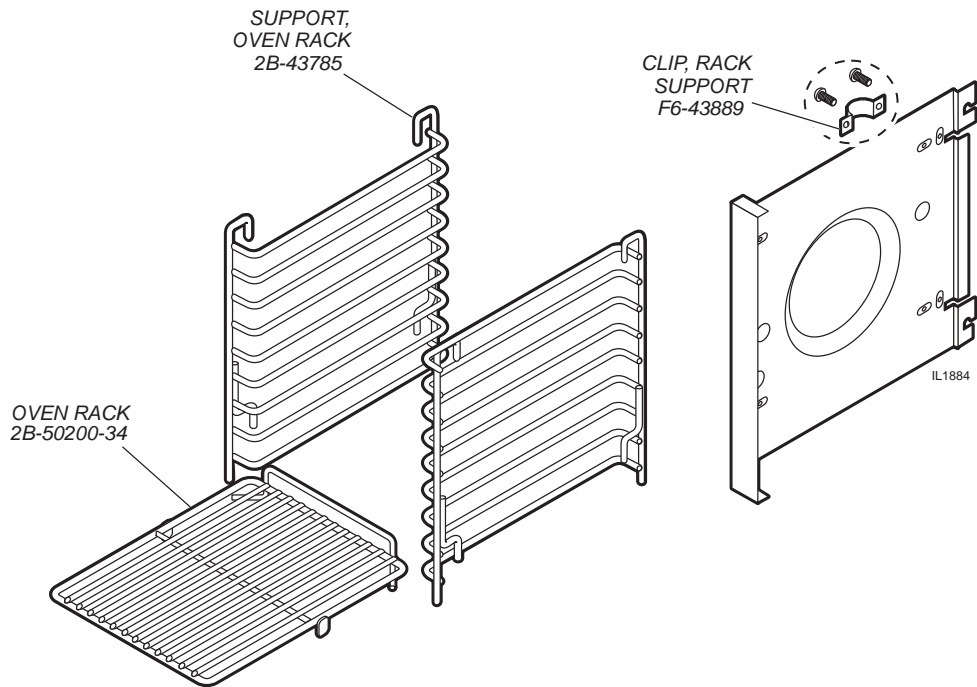

WIRING DIAGRAM
ROBERTSHAW OVEN CONTROL

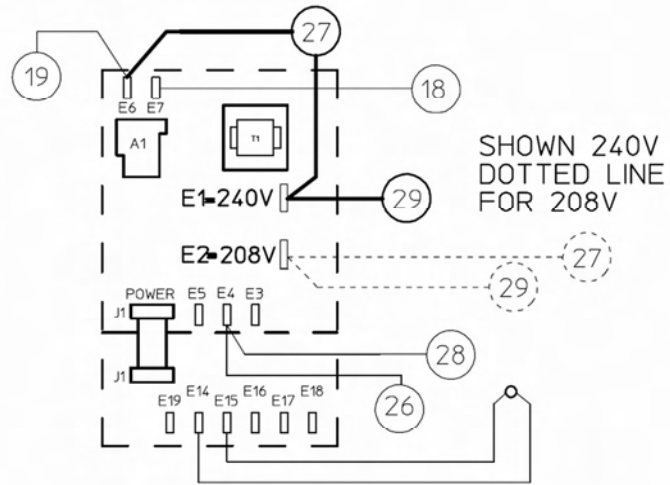

WIRING DIAGRAM
NCC OVEN CONTROL

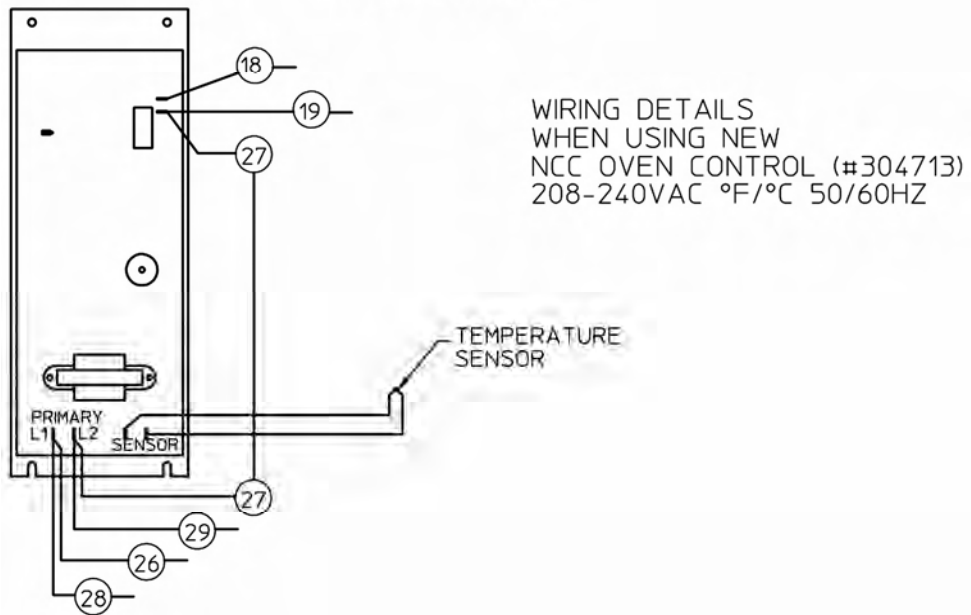

M273 p/n 2M-303875 Owners Manual OC-1 & OC-4 Half-Size Convection Ovens

WIRING DIAGRAM

WIRING DIAGRAM FOR OC-1 W/ROBERTSHAW CONTROL
SINGLE PHASE 208 OR 240V

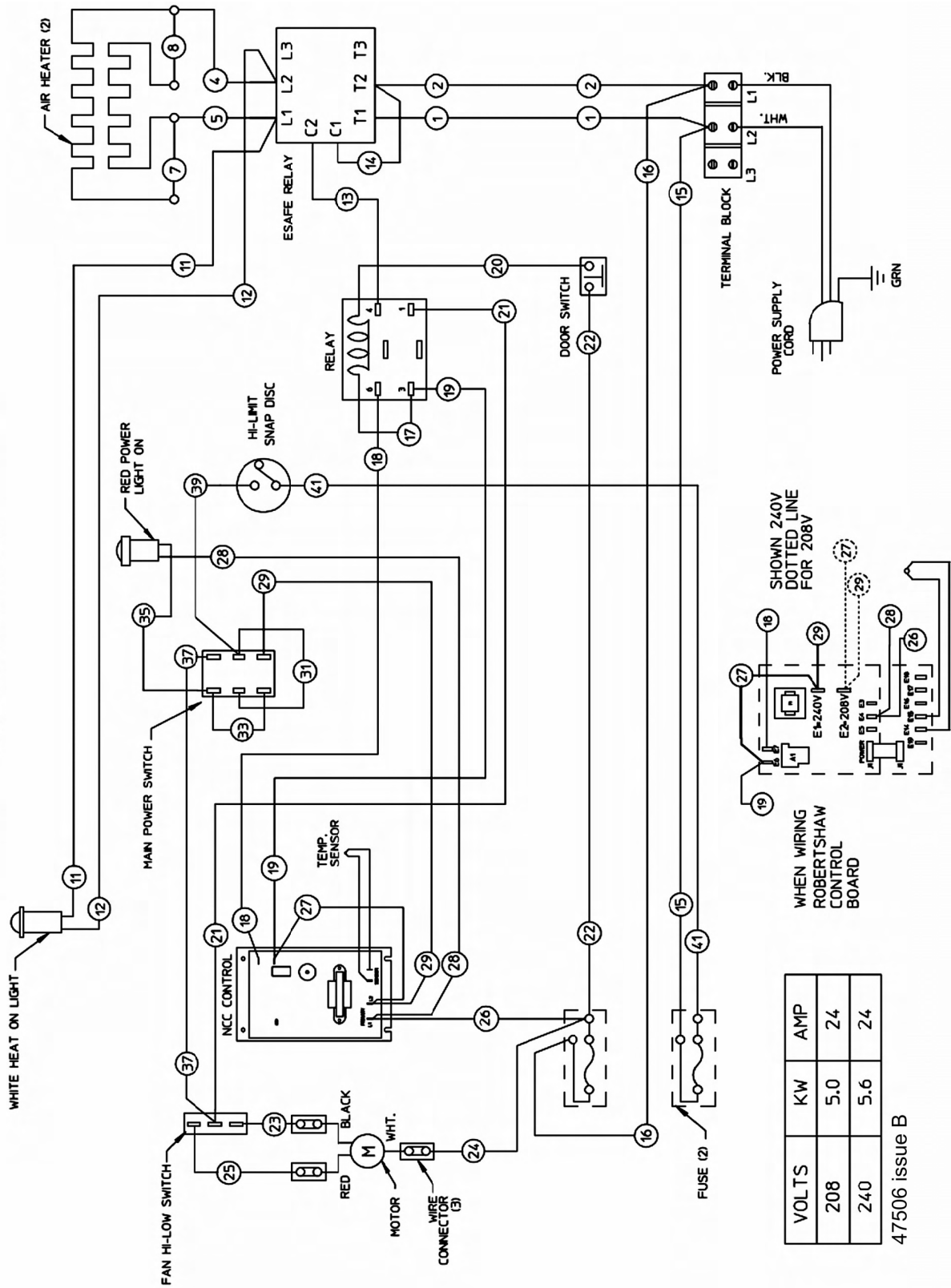

WIRING DIAGRAM

WIRING DIAGRAM FOR OC-4HC OVEN
208 OR 240V VOLT, THREE PHASE

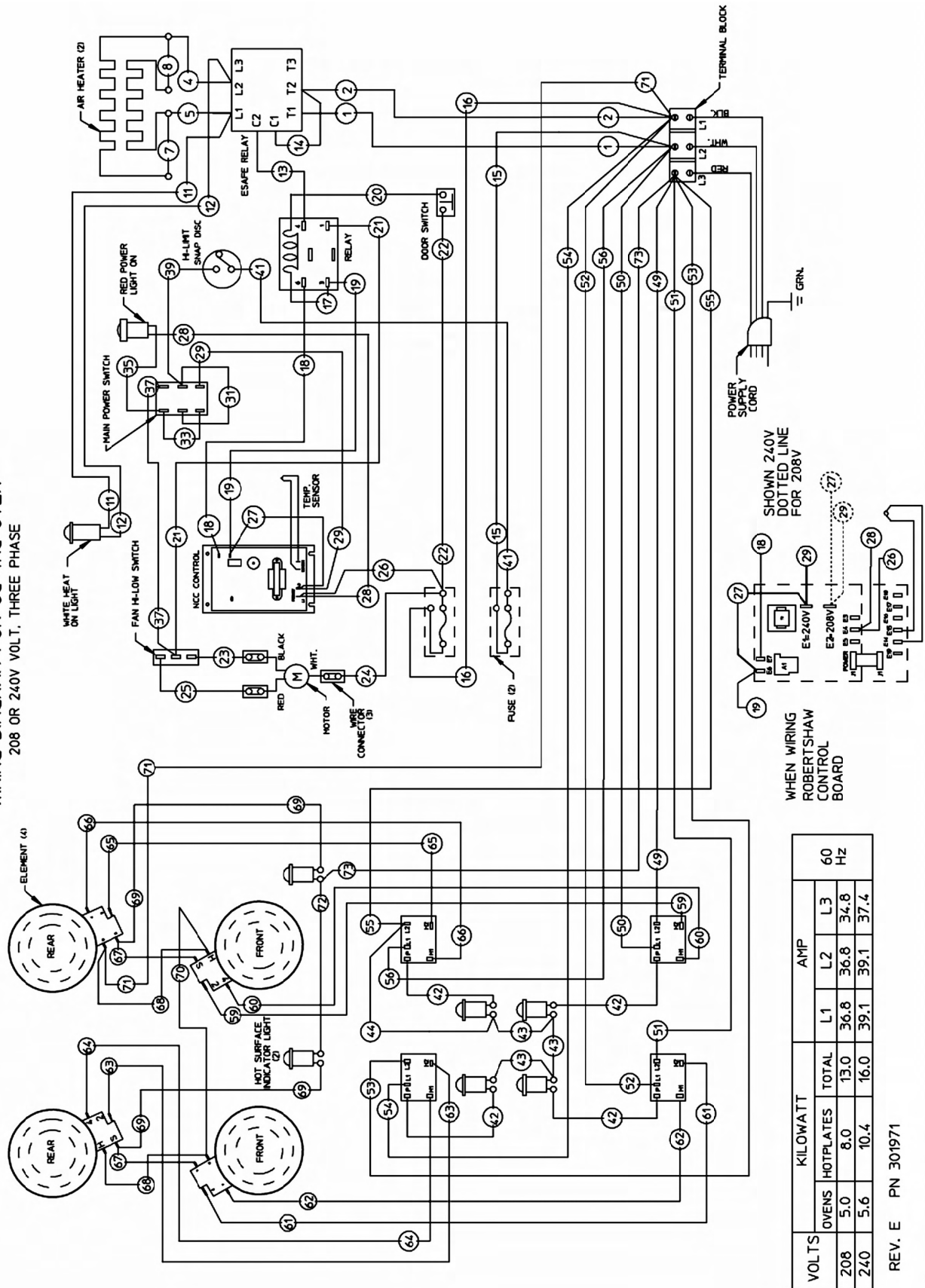

VOLTS	KILOWATT			AMP		
	OVENS	HOTPLATES	TOTAL	L1	L2	L3
208	5.0	8.0	13.0	36.8	36.8	34.8
240	5.6	10.4	16.0	39.1	39.1	37.4

REV. E PN 301971

WIRING DIAGRAM COOKTOP SECTION of OC-4HS
208/240 VOLT 3 ϕ

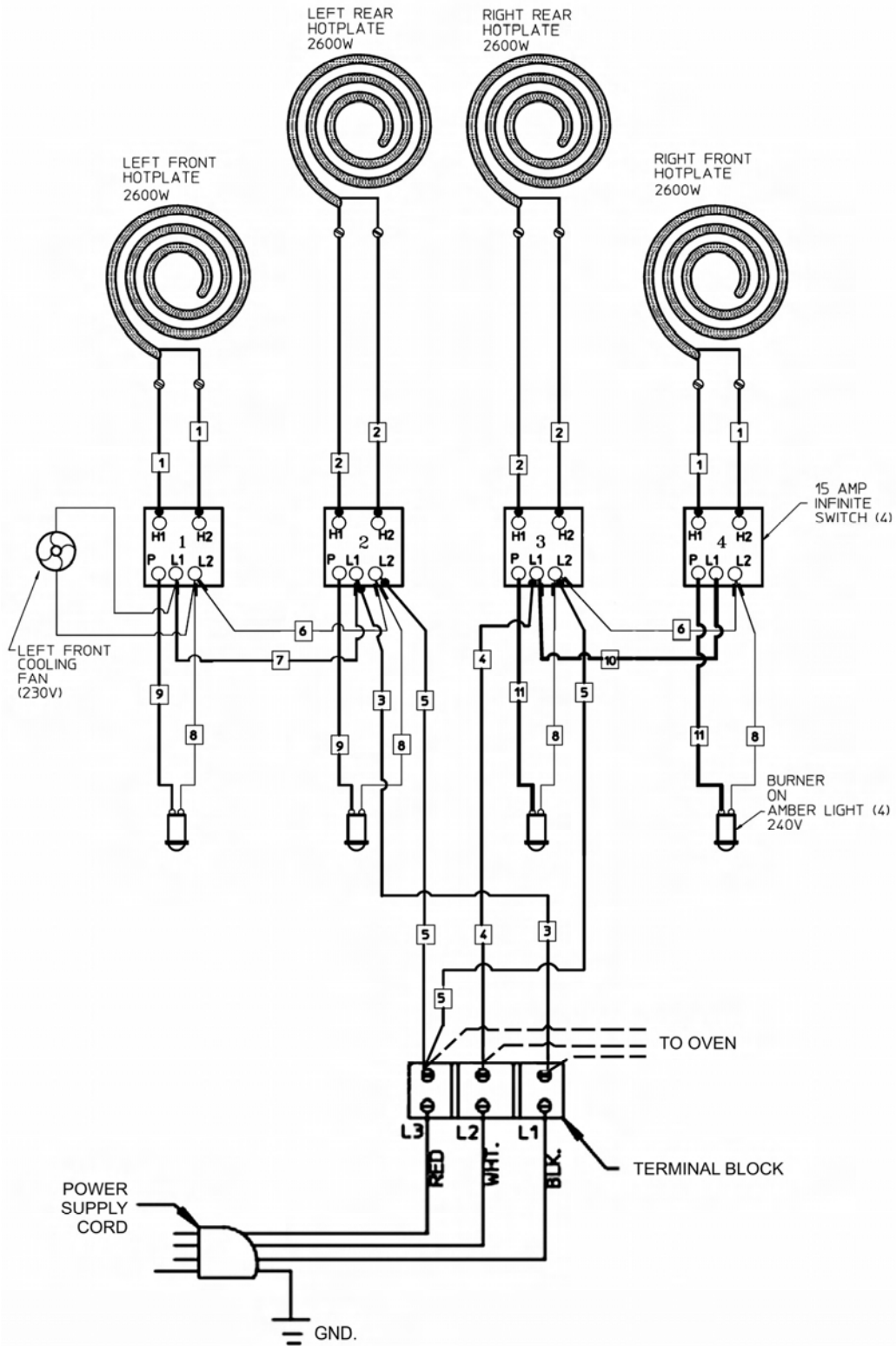

PARTS & SERVICE

DESCRIPTION

PART NO.

CASTERS (Set of 4 casters)	5F-21330
OVEN RACK Replacement	5F-21376
PREP TOP KIT	5F-21445
DRIP TRAY, COIL-TYPE ELEMENT	5I-21705
LEGS, 6" Stainless Steel (Set of 4 legs)	2A-22226
ELEMENT SUPPORT, COIL-TYPE ELEMENT	DD-500039

IMPORTANT: Use only factory authorized service parts and replacement filters.

For factory authorized service, or to order factory authorized replacement parts, contact your Wells authorized service agency, or call:

Wells Manufacturing
265 Hobson Street
Smithville, Tennessee 37166 U.S.A.

Service Dept.
phone: (800) 807-9054
fax: (314) 781-2714

Service Parts Department can supply you with the name and telephone number of the **WELLS AUTHORIZED SERVICE AGENCY** nearest you.

CUSTOMER SERVICE DATA

please have this information available if calling for service

RESTAURANT _____ LOCATION _____
INSTALLATION DATE _____ TECHNICIAN _____
SERVICE COMPANY _____
ADDRESS _____ STATE _____ ZIP _____
TELEPHONE NUMBER (_____) _____ - _____

EQUIPMENT MODEL NO. _____
EQUIPMENT SERIAL NO. _____

VOLTAGE: (check one) 208 240 480



SERVICE TRAINING - QUALITY SERVICE



CUSTOMER SATISFACTION



WELLS MANUFACTURING

265 Hobson Street, Smithville, Tennessee 37166

telephone: 314-781-2777

fax: 314-781-2714

www.wells-mfg.com