

**WELLS MANUFACTURING**

265 Hobson Street, Smithville, Tennessee 37166

telephone: 314-678-6314

fax: 314-781-2714

[www.wells-mfg.com](http://www.wells-mfg.com)

042



*Model RW26HD*



*Model RWN26*

**OWNERS MANUAL**

**BUILT-IN DRAWER  
WARMERS  
with THERMOSTATIC  
CONTROL**

**MODELS  
RW16HD  
RW26HD  
RW36HD  
RW176HD**

**RWN16  
RWN26  
RWN36**

**Includes  
INSTALLATION  
USE & CARE  
EXPLODED VIEW  
PARTS LIST  
WIRING DIAGRAM**

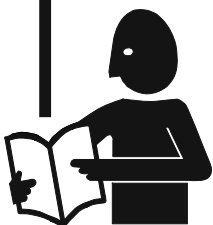

**IMPORTANT: DO NOT DISCARD THIS MANUAL**

This manual is considered to be part of the appliance and is to be given to the OWNER or MANAGER of the restaurant, or to the person responsible for TRAINING OPERATORS of this appliance. Additional manuals are available from your WELLS DEALER.

**THIS MANUAL MUST BE READ AND UNDERSTOOD BY ALL PERSONS USING OR INSTALLING THIS APPLIANCE.** Contact your WELLS DEALER if you have any questions concerning installation, operation or maintenance of this equipment.

## LIMITED EQUIPMENT WARRANTY

Wells Manufacturing warranties new products to be free from defects in material and/or workmanship for a period of one [1] year from the date of original installation, except as noted below. Defects that occur as a result of normal use, within the time period and limitations defined in this warranty, will at Wells' discretion have the parts replaced or repaired by Wells or a Wells-authorized service agency.

### THIS WARRANTY IS SUBJECT TO ALL LISTED CONDITIONS.

Repairs performed under this warranty are to be performed by a Wells-authorized service agency. Wells will not be responsible for charges incurred or service performed by non-authorized repair agencies.

In all cases, the nearest Wells-authorized service agency must be used.

Wells will be responsible for normal labor charges incurred in the repair or replacement of a warrantied product within 50 miles (80.5 km) of an authorized service agency. Time and expense charges for anything beyond that distance will be the responsibility of the owner. All labor will need to be performed during regular service hours. Any overtime premium will be charged to the owner. For all shipments outside the U.S.A. and Canada, please see the International Warranty for specific details.

It is the responsibility of the owner to inspect and report any shipping damage claims, hidden or otherwise, promptly following delivery.

No mileage or travel charges will be honored on any equipment that is deemed portable. In general, equipment with a cord and plug weighing less than 50 lb. (22.7 kg) is considered portable and should be taken or shipped to the closest authorized service agency, transportation prepaid.

### CONTACT

Should you require any assistance regarding the operation or maintenance of any Wells equipment; write, phone, fax or email our service department. In all correspondence mention the model number and the serial number of your unit, as well as the voltage or type of gas you are using.

Business hours are 8:00 a.m. to 4:30 p.m. Central Standard Time  
 Telephone 314.678.6314  
 Fax 314.781.2714  
 Email customerservice@star-mfg.com  
 www.wells-mfg.com

## WARRANTY EXCLUSIONS

THE FOLLOWING WILL NOT BE COVERED UNDER WARRANTY.

- Any product which has not been installed, cleaned, maintained, or used in accordance with the directions published in the appropriate installation sheet and/or owner's manual as well as national and local codes, including incorrect gas or electrical connection. Wells is not liable for any unit which has been mishandled, abused, misapplied, subjected to chlorides, harsh chemicals, or caustic cleaners, damaged from exposure to hard water, modified by unauthorized personnel, damaged by flood, fire, or other acts of nature [or God], or which have an altered or missing serial number.
- Installation, labor, and job checkouts, calibration of heat controls, air and gas burner/bypass/pilot adjustments, gas or electrical system checks, voltage and phase conversions, cleaning of equipment, or seasoning of griddle surface.
- Replacement of fuses or resetting of circuit breakers, safety controls, or reset buttons.
- Replacement of broken or damaged glass components, quartz heating elements, and light bulbs.
- Labor charges for all removable parts in gas charbroilers and hotplates, including but not limited to burners, grates, and radiants.
- Any labor charges incurred by delays, waiting time, or operating restrictions that hinder a service technician's ability to perform service.
- Parts that fail or are damaged due to normal wear or labor for replacement of Items that can easily be replaced during a daily cleaning routine. such as but not limited to silicone belts, PTFE non-stick sheets, knobs, control labels, bulbs, fuses, quartz heating elements, baskets, racks, and grease drawers.
- Components that should be replaced when damaged or worn, but have been field-repaired instead [eg. field-welded fry pots].
- Any loss of business or profits.

### ADDITIONAL WARRANTIES

Specialty/chain specific versions may also have additional and/or extended warranties.

PRODUCTS	PARTS	LABOR
universal ventless hoods	2 years	1 year
canopy hoods	2 years	1 year
"Cook'n Hold" equipment [HW10, HWSMP, LLSC7, LLSC7WA, LLSC11, and LLSC11WA]	2 years	1 year
cast iron grates, burners, and burner shields	1 year	
original Wells parts sold to repair Wells equipment	90 days	
Service First	1 year	

## TABLE OF CONTENTS

WARRANTY	1
SPECIFICATIONS	2
FEATURES & OPERATING CONTROLS	3
PRECAUTIONS & GENERAL INFORMATION	3
AGENCY LISTING INFORMATION	3
INSTALLATION	4
OPERATION	6
CLEANING INSTRUCTIONS	8
TROUBLESHOOTING SUGGESTIONS	9
MAINTENANCE INSTRUCTIONS	10
NOTES	11
EXPLODED VIEW & PARTS LIST	12—13
WIRING	14
PARTS & SERVICE	17
CUSTOMER SERVICE DATA	14

## INTRODUCTION

Thank You for purchasing this Wells Bloomfield appliance.

Proper installation, professional operation and consistent maintenance of this appliance will ensure that it gives you the very best performance and a long, economical service life.

This manual contains the information needed to properly install this appliance, and to use and care for the appliance in a manner which will ensure its optimum performance.

## SPECIFICATIONS

MODELS	VOLTS 50/60 Hz 1Ø	WATTS	AMPS	POWER SUPPLY WIRING REQUIRED
RW16HD, RWN16	120 VAC	450 W	3.8	120 VAC (L1, Neut., Gnd.)
	208/240 VAC	338/450 W	1.6/1.9	208 or 240VAC (L1, L2, Gnd.)
RW26HD, RWN26	120 VAC	900 W	7.5	120 VAC (L1, Neut., Gnd.)
	208/240 VAC	676/900 W	3.3/3.8	208 or 240VAC (L1, L2, Gnd.)
RW36HD, RWN36	120 VAC	1350 W	11.3	120 VAC (L1, Neut., Gnd.)
	208/240 VAC	1014/1350 W	4.9/5.6	208 or 240VAC (L1, L2, Gnd.)

# FEATURES & OPERATING CONTROLS

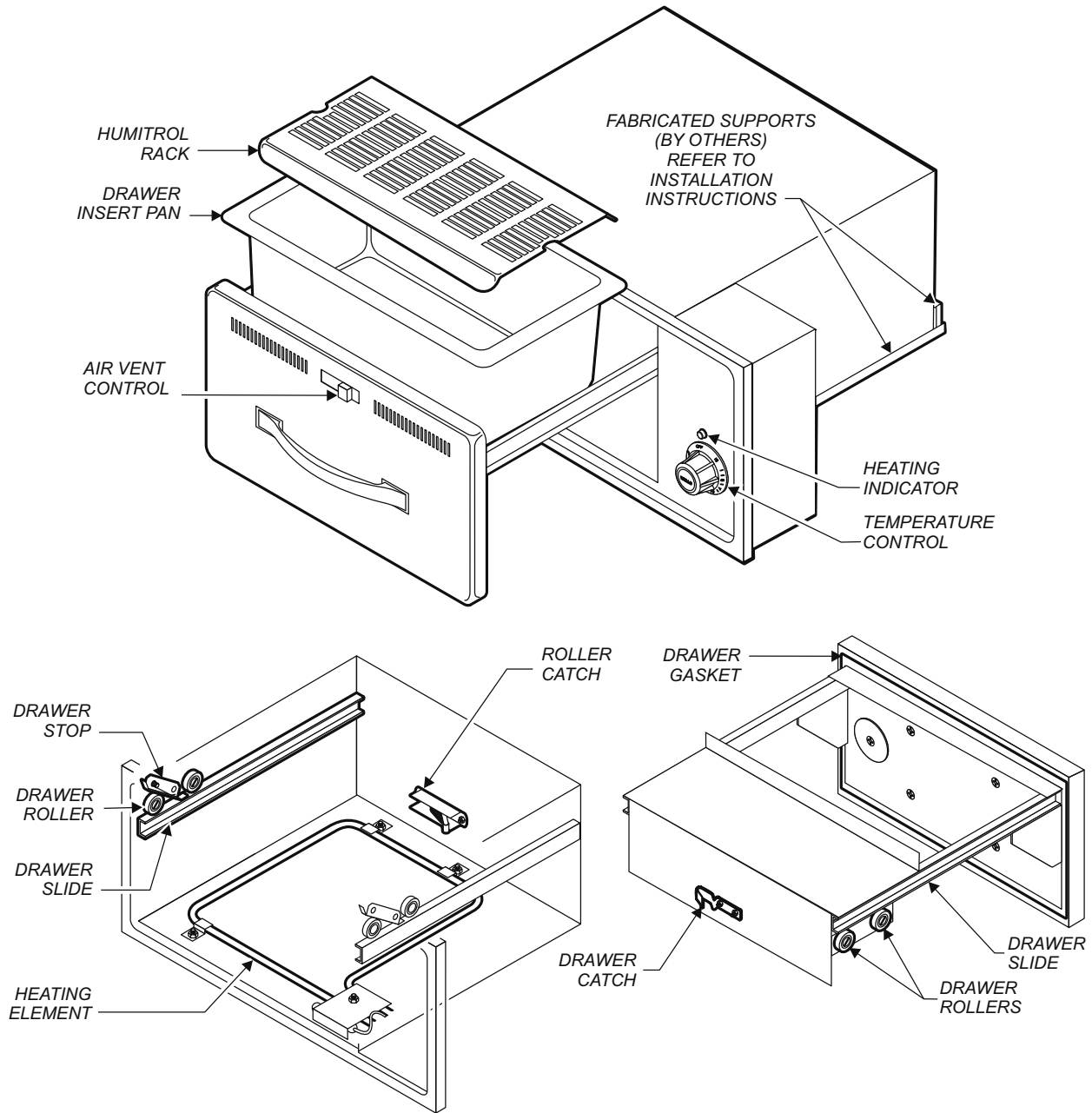

M042 p/n 214-303334 Owners Manual Built-In Drawer Warmer

## PRECAUTIONS AND GENERAL INFORMATION

This appliance is intended for use in commercial establishments only.

This appliance is intended to prepare food for human consumption. No other use is recommended or authorized by the manufacturer or its agents.

Operators of this appliance must be familiar with the appliance use, limitations and associated restrictions. Operating instructions must be read and understood by all persons using or installing this appliance.

Cleanliness of this appliance is essential to good sanitation. Read and follow all included cleaning instructions and schedules to ensure the safety of the food product.

Disconnect this appliance from electrical power before performing any maintenance or servicing.

**DO NOT** submerge this appliance in water. This appliance is not jet stream approved. Do not direct water jet or steam jet at this appliance, or at any control panel or wiring. Do not splash or pour water on, in or over any controls, control panel or wiring. Do not wash floor around this appliance with water or steam jet.

Exposed surfaces of this appliance can be hot to the touch and may cause burns.

Heating element will be very hot when in use. Contact may cause serious burns.

The technical content of this manual, including any wiring diagrams, schematics, parts breakdown illustrations and/or adjustment procedures, is intended for use by qualified technical personnel.

Any procedure which requires the use of tools must be performed by a qualified technician.

This manual is considered to be a permanent part of the appliance. This manual and all supplied instructions, diagrams, schematics, parts breakdown illustrations, notices and labels must remain with the appliance if it is sold or moved to another location.

This appliance is made in the USA. Unless otherwise noted, this appliance has American sizes on all hardware.



### WARNING: SHOCK HAZARD

All servicing requiring access to non-insulated electrical components must be performed by a factory authorized technician. DO NOT open any access panel which requires the use of tools. Failure to follow this warning can result in severe electrical shock.



### CAUTION: RISK OF DAMAGE

DO NOT connect or energize this appliance until all installation instructions are read and followed. Damage to the appliance will result if these instructions are not followed.



### CAUTION: HOT SURFACE



Exposed surfaces can be hot to the touch and may cause burns.

## AGENCY LISTING INFORMATION

This appliance conforms to NSF Standard 4 for sanitation only if installed in accordance with the supplied *Installation Instructions* and maintained according to the instructions in this manual.

### IMPORTANT:

RW- models are **NOT** NSF approved for potentially hazardous foods.

This appliance is  and  Listed under UL File E6070 for 120V, 208V and 240V.



STD 4



E6070



E6070

## INSTALLATION

**NOTE: DO NOT** discard the carton or other packing materials until you have inspected the appliance for hidden damage and tested it for proper operation.

Refer to *SHIPPING DAMAGE CLAIM PROCEDURE* on the inside front cover of this manual.



### **WARNING: RISK OF INJURY**

Installation procedures must be performed by a qualified technician with full knowledge of all applicable electrical and plumbing codes. Failure can result in personal injury and property damage.



### **WARNING: SHOCK HAZARD**

All servicing requiring access to non-insulated electrical components must be performed by a factory authorized technician. **DO NOT** open any access panel which requires the use of tools. Failure to follow this warning can result in severe electrical shock.

## UNPACKING & INSPECTION

Carefully remove the appliance from the carton. Remove all protective plastic film, packing materials and accessories from the Appliance before connecting electrical power or otherwise performing any installation procedure.

Carefully read all instructions in this manual and the *Installation Instruction Sheet* packed with the appliance before starting any installation.

Read and understand all labels and diagrams attached to the appliance.

Carefully account for all components and accessories before discarding packing materials. Store all accessories in a convenient place for later use.

## COMPONENTS

- 1 - 3 ea. DRAWERS (qty. depends on model)
- 1 - 3 ea. HUMITROL RACKS (if ordered with unit)

## FABRICATION

Refer to *INSTALLATION INSTRUCTIONS* for cutout dimensions and support fabrication information.

1. Layout front panel cutout dimensions. Cut hole in counter front panel.
2. Position supplied mounting flange in hole to determine hole location. Drill hole using #34 drill.
3. Attach flange to front panel using the provided #6 screws.
4. Fabricate rails and rear support as shown in instructions.

## INSTALLATION

Refer to electrical specifications on page 1. Circuit must meet or exceed the amperage and wattage requirements listed.

1. For ease of installation, remove drawer from unit.
2. Slide unit through front panel opening until rear of unit rests on the rear support.
3. Remove TEMPERATURE CONTROL KNOB and CONTROL PANEL.
4. Install provided #8-32 speednuts on mounting flange. Secure mounting flange to the front panel and secure unit to mounting flange using the provided #8-32 flathead screws.
5. Connect power leads (including ground lead). Wiring or conduit must be secured to the warmer with a suitable strain relief (provided by electrical installer).
6. Reinstall CONTROL PANEL and TEMPERATURE CONTROL KNOB.

## INSTALLATION (continued)

7. Reinstall drawer(s) in unit:
  - a. Check the roller catch inside the cabinet. The spring-loaded roller arm must be extended.
  - b. With the front of the drawer assembly tipped downward, engage the roller on the drawer with the cabinet drawer slide.
  - c. Raise the drawer to the horizontal position until the drawer-mounted slide engages the dual roller assembly on the cabinet.
  - d. Slide the drawer in until the catch engages. The drawer should remain tightly closed.
  - e. Slide the drawer out. The drawer stop should prevent the drawer from coming all of the way out.
  - f. Install drawer insert pans.

Avoid storing flammable or combustible materials in, on or near the appliance.



### **WARNING: SHOCK HAZARD**

All servicing requiring access to non-insulated electrical components must be performed by a factory authorized technician. DO NOT open any access panel which requires the use of tools. Failure to follow this warning can result in severe electrical shock.



### **CAUTION: RISK OF DAMAGE**

DO NOT connect or energize this appliance until all installation instructions are read and followed. Damage to the appliance will result if these instructions are not followed.

### **IMPORTANT:**

Contact a licensed electrician to install and connect electrical power to the appliance.

### **IMPORTANT:**

Damage due to being connected to the wrong voltage or phase is NOT covered by warranty.

## OPERATION



### CAUTION: HOT SURFACE

Exposed surfaces can be hot to the touch and may cause burns.

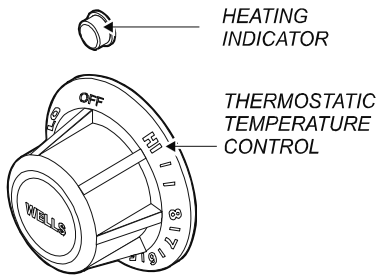

### NOTE:

The chart below is intended as a guide ONLY. Your own experience with this appliance, type of foods and method of operation will enable you to determine the temperature control and air vent settings best suited to your operation.

## HEATING OPTIONS

1. Moist heat with Humitrol Rack:
  - a. MOIST operation prevents food from drying out as heat is applied to the warming chamber.
  - b. To set for MOIST operation, remove the Humitrol Rack from bottom of drawer insert pan and carefully pour approximately 2 quarts of water ( $\frac{1}{2}$ " depth) into the pan. Reinstall rack.
  - c. When the drawer is closed, the Humitrol Rack allows water vapor to rise through the stored product in the drawer. The Humitrol Rack also decreases the sloshing effect of the water in the pan when the drawer is opened.
  - d. Place the food directly on the rack. The rack is designed to support the food off of the steam vents, where water droplets may form.
  - e. Check the water level in the pan periodically, and add water when necessary.
  - f. Set the front air vent between fully closed and half-open. Actual setting will depend upon the type and amount of product stored in the drawer, the temperature setting, and the frequency with which the drawer is opened.
2. Moist heat with pans:
  - a. This Wells warmer is designed to accommodate any combination of standard-size, steam table pans.
  - b. Place a small amount of water in drawer pan. Place the steam table pans in the drawer pan.
  - c. Check the water level in the pan periodically, and add water when necessary.
3. Dry heat:
  - a. For some applications, you may want to store previously prepared foods in a dry-heat environment. To do so, place the food directly into the empty (i.e. no water) drawer pan.

## OPERATING CHART FOR DRAWER WARMERS

PRODUCT TYPE	RECOMMENDED STORAGE TEMP.	TYPE OF HEAT	CONTROL SETTING	AIR VENT SETTING
Hard Rolls	160-185°F	Dry	7-8	Full Open
Soft Rolls	150-175°F	Moist	6-7	Open - $\frac{1}{2}$
Vegetables	175-185°F	Moist	7-8	Open - $\frac{1}{2}$
Meats	165-185°F	Dry	6-8	Full Open
Fish	165-185°F	Moist	6-8	Closed
Casseroles	150-175°F	Dry	6-7	Full Open
Pies, Desserts	160-185°F	Dry	6-7	Full Open
Taco Shells	150-170°F	Dry	4-6	Full Open
Corn Chips	150-170°F	Dry	4-6	Full Open

do not put water in the pan



**OPERATION**

1. Determine the type of food to be warmed.
2. Refer to the chart on page 6 to determine the type of heat required.
3. Set the air vent control for the type of heat, and rotate the thermostat knob to the temperature setting desired.
4. Allow warmer to pre-heat for approximately 30 minutes before use.

**DO'S and DON'TS**

1. **DO** Always use a drawer pan.  
**DO NOT** Place food directly into the warmer cavity.
2. **DO** Check water level in moist-operation warmer frequently during use.  
**DO** Use a Humitrol Rack or Insets to hold food for moist operation.
3. **DO** Use warm water to add to the pan during moist operation.  
**DO NOT** Put ice into a warmer pan. Ice in the pan will cause condensation on the inside of the warmer cavity.



**CAUTION:  
HOT SURFACE**

Exposed surfaces can be hot to the touch and may cause burns.

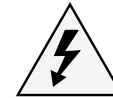

**CAUTION:  
SHOCK HAZARD**

**DO NOT** splash or pour water onto control panel or wiring.

**IMPORTANT:**

**DO NOT** place food directly into the warmer cavity. Always use a drawer pan.

**IMPORTANT:**

**DO NOT** put ice into a warmer pan. Ice in the pan will cause condensation on the inside of the warmer cavity. Damage caused by this type of condensation is **NOT** covered by warranty.

## CLEANING INSTRUCTIONS

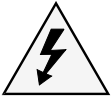

### CAUTION: SHOCK HAZARD

Disconnect appliance from electric power before cleaning.



### CAUTION: HOT SURFACE

Exposed surfaces can be hot to the touch and may cause burns. Allow appliance to cool before cleaning.

**PRECAUTIONS:** Turn control knob to OFF.  
Allow drawers to cool before proceeding.  
Remove drawer pans and Humitrol racks.

**FREQUENCY:** Minimum -Daily

**TOOLS:** Warm water and mild detergent  
Clean cloth or sponge

1. Remove drawers from warmer:
  - a. Pull warmer drawer out until fully extended.
  - b. Slide finger along left and right slide rail until you reach the latches (located at the front end of the cabinet-mounted rails). Press down on both left and right latch.
  - c. Pull drawer away from warmer.

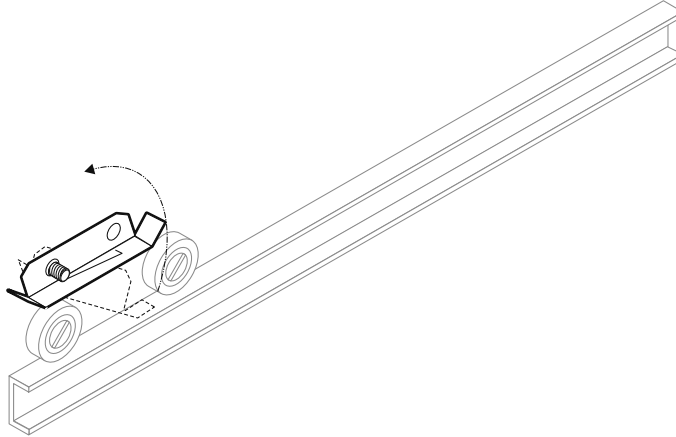

2. Clean drawers, drawer pans, Humitrol Racks and/or insets with warm water and mild detergent. Rinse all components thoroughly with clear water. Dry all components prior to reinstalling them in warmer.
3. Sweep crumbs and other debris from warmer cavity.
4. Clean the outside of the unit by wiping with a clean cloth or sponge, warm water and mild detergent. Dry with a clean cloth, then wipe with a polish formulated for stainless steel.
5. It is important to keep the slide rails clear and free from debris. Periodic cleaning of the slide rails and other adjoining parts is necessary to assure smooth drawer operation.
6. Check drawer rollers. Be sure they roll freely and that the slide rails are free from debris.
7. Be sure cabinet-mounted drawer catch roller is "up", then re-install drawers.

## TROUBLESHOOTING SUGGESTIONS

SYMPTOM	POSSIBLE CAUSE	SUGGESTED REMEDY
No lights or heat (all drawers)	Warmer unplugged	Plug warmer into appropriate receptacle
	Circuit breaker off or tripped	Reset circuit breaker
	Internal damage	Contact an Authorized Wells Service Agency for repairs.
No heat (one drawer)	Temperature control not set	Set for desired temperature.
	Internal damage	Contact an Authorized Wells Service Agency for repairs.
Food dries out	Humidity control (air vent) not set	OPEN air vent for dry operation. CLOSE air vent for moist operation.
	Water in pan evaporated or low	Add water to pan.
Food gets soggy	Food contacting water	Use a Humitrol Rack
	Water level too high	Water should be no more than 1/2" deep
	Humidity control (air vent) not set	OPEN air vent for dry operation. CLOSE air vent for moist operation.
Drawer falls open	Catch roller not extended before closing drawer	Be sure catch roller is extended before installing drawer.
	Drawer catch damaged	Contact an Authorized Wells Service Agency for repairs.
Drawer falls out when opened	Drawer stop dirty	Clean and lubricate drawer stop
	Drawer stop damaged	Contact an Authorized Wells Service Agency for repairs.

## MAINTENANCE INSTRUCTIONS (continued)



### CAUTION: SHOCK HAZARD

Disconnect appliance from electric power before cleaning.



### CAUTION: HOT SURFACE

Exposed surfaces can be hot to the touch and may cause burns. Allow appliance to cool before servicing.

## ADJUSTMENTS AND LUBRICATION

**PRECAUTIONS:** Turn control knob to OFF. Unplug warmer. Allow drawers to cool before proceeding. Remove drawer pans and Humitrol racks.

**FREQUENCY:** Minimum - monthly. Every 2 weeks recommended.

**TOOLS:** Screwdrivers, Phillips (+) and flat blade (-). Nut drivers, 3/8" and 7/16". Food-grade lubricant.

1. Check slides on cabinet and drawers for cleanliness.
2. Check all rollers on cabinet and drawers for cleanliness and tightness. Lubricate.
3. Check cabinet drawer stops for operation. Stops must "snap" down positively. Clean and adjust as required.
4. Check cabinet heating element fasteners for tightness.
5. Check all cabinet drawer catches for tightness and operation. Lubricate. Be certain roller is "out" before attempting to install drawer.
6. Check thermostat thermobulb and capillary tube for condition. Thermobulb must be securely mounted in the appropriate holder. Arrange repairs for damaged thermobulb or capillary tube.
7. Check drawer faceplate and handle fasteners for tightness.
8. Check drawer catch clip for tightness.
9. For drawers equipped with gaskets, examine condition of gasket. Arrange repairs for torn or damaged gaskets.
10. Reinstall drawers and check for proper operation.

Procedure is complete.

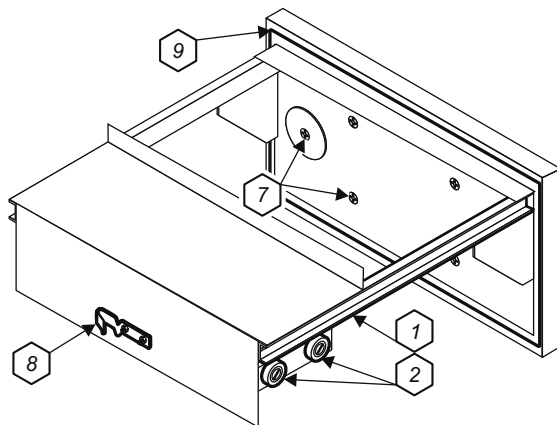
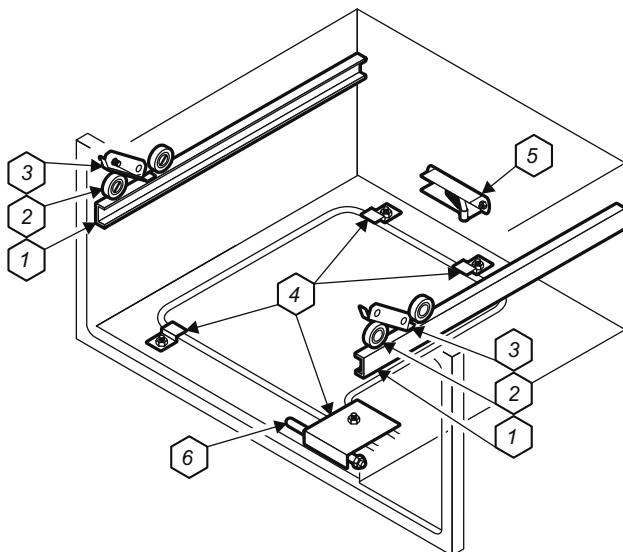

NOTES:

**EXPLODED VIEW: RW16HD—RW36HD, RWN16—RWN36, RW176HD**

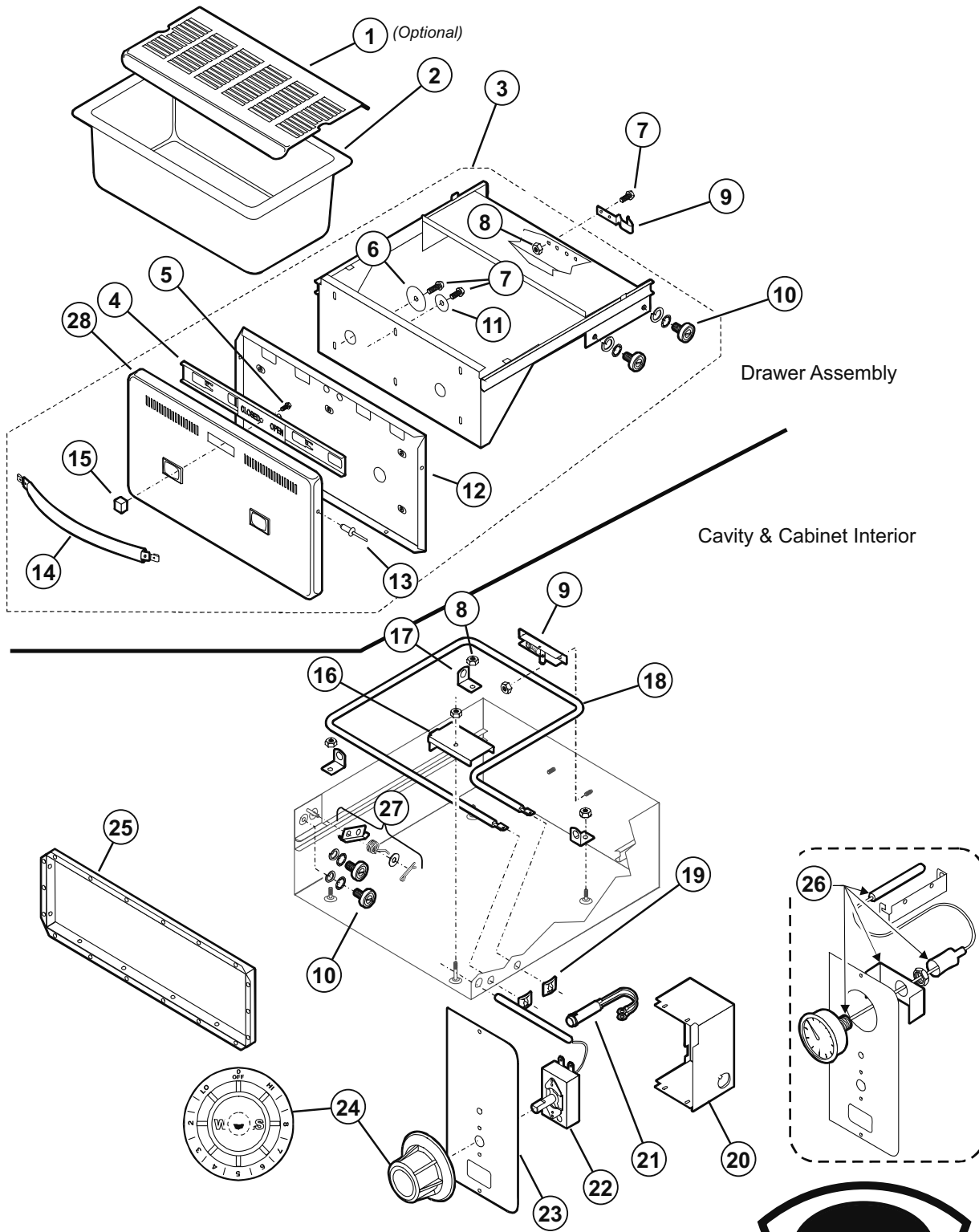

**Model:** RW16HD - RW36HD, RWN16 - RWN36, RW176HD  
**Built-In Drawer Warmer**  
**Cabinet & Electrical 120V/208/240/480V**  
 PL042



IL1762 Rev. C 4/23/14

M042 p/n 214-303334 Owners Manual Built-In Drawer Warmer

**PARTS LIST: RW16HD - RW36HD, RWN16—RWN36, RW176HD**

<b>BUILT-IN DRAWER WARMER</b>		<b>Applications</b>		
<b>Fig No</b>	<b>Description</b>	<b>RW16/26/36H D</b>	<b>RW176HD</b>	<b>RWN16/26/36</b>
1	RACK HUMITROL RWS	WS-20624	DD-300659	WS-20624
2	PAN INSERT DRAWER RWHD	C8-46840		C8-49252
3	DRAWER ASY KIT RWHD	WS-67096	DD-506374	WS-69244
4	SLIDE VENT ASSY RWN	C8-49251	C8-35726	C8-49251
5	SCREW 8-32X3/8PH RD	2C-35530		
6	WASHER 2 1/4" DRWR BACK	2C-35565		
7	SCREW 8-32X5/16 PH TR HD	2C-35487		
8	NUT 8-32 HEX MS SS	2C-35455		
9	CATCH IVES MACH	2C-30471		
10	BEARING ROLLER TRACK	2P-30483		
11	WASHER FLAT SS 1/4X 1 1/4	2C-41791		
12	PANEL BACK DRWR RW	C8-44291		
13	RIVET POP 1/8X.265 SS	2C-49395		
14	HANDLE R W DRAWER	C8-32112		C8-49248
15	KNOB SQR ROLL WARMER VENT	WS-51796		
16	SHIELD BULB RWS	C8-35683		
17	BRKT ELEM MTG RW	C8-35677		
18	ELEM 120V	2N-30519UL	DD-300449	2N-49255UL
	ELEM 208/220/240V (CE)	2N-30482UL	2N-300951UL	2N-49475UL
19	CLIP RETAINER PILOT LIGHT	2C-43271		
20	BOX OUTLET RW RW350	C8-307569		
21	LIGHT SIGNAL GLO DOT	2J-35687		
22	THERMO CTRL RW W/O AUX	WS-58936		
23	PANEL CONTROL RW RW324	C8-31801	C8-Z12394	
	PANEL CONTROL LOWER	C8-33565		
24	KNOB CONTROL ASSY WARM	2R-30372		
25	FLANGE ATTACH ASSY	C8-40447		
26	THERMOMETER RW 2IN DIAL	2T-44475		
27	KIT REPAIR DWR STOP	WS-65923	WS-65923	
-	PIN COTTER S/S 1/16 X 3/8	2C-40019	2C-40019	
-	STOP ASSY DRAWER	C9-45447	C9-45447	
-	SPRING DRAWER RT	2P-45448	2P-45448	
-	SPRING DRAWER LT	2P-45449	2P-45449	
-	WASHER FLAT .235 X .5 X .48	2C-45610	2C-45610	
-	SPRING DRAWER STOP RT	2P-307827	2P-307827	
-	SPRING DRAWER STOP LT	2P-307828	2P-307828	
28	PANEL FRONT DRW RW	C8-43191	C8-49249	

M042 p/n 2M-303334 Owners Manual Built-In Drawer Warmer

# WIRING DIAGRAM

## WIRING DIAGRAM

FREE STANDING AND BUILT-IN  
Model RW-Series with Cap & bulb thermostat

VOLTS	AMPERES			HZ
	1-DWR	2-DWR	3-DWR	
120	3.8	7.5	11.3	50
208	1.6	3.3	4.9	/ 60
230	1.8	3.6	5.4	
240	1.9	3.8	5.6	

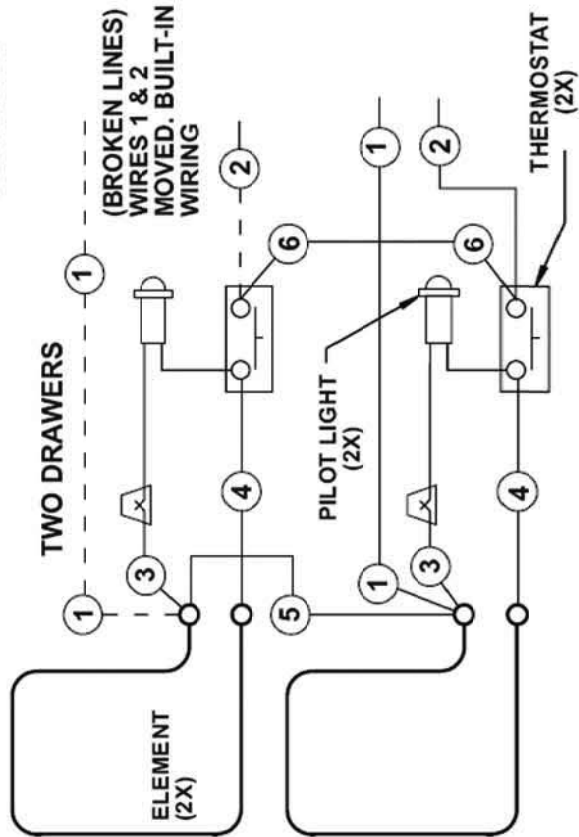
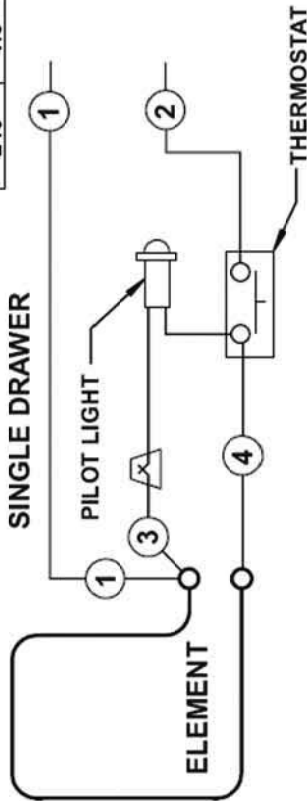

POWER CORD STANDARD ON COUNTER-TOP MODELS  
POWER CORD OPTIONAL ON BUILT-IN MODELS

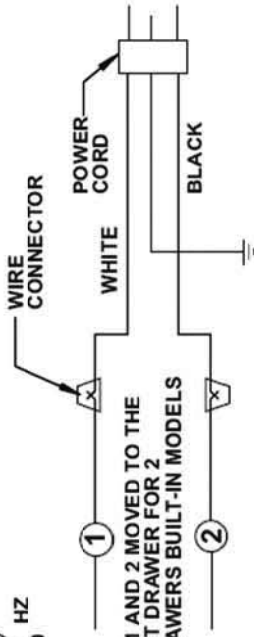

NOTE:  
WIRES #1 AND 2 MOVED TO THE  
TOPMOST DRAWER FOR 2  
OR 3 DRAWERS BUILT-IN MODELS

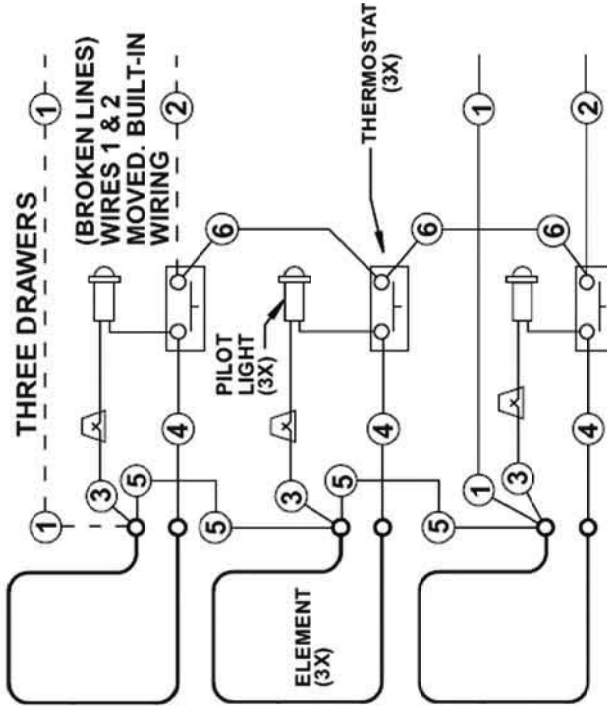

307640 (A)





**NOTES**

## PARTS & SERVICE

### DESCRIPTION

HUMITROL RACK  
PAN, STAINLESS (ALL EXCEPT RWN)  
PAN, STAINLESS (RWN ONLY)

### PART NO.

WS-20624  
C8-46840  
C8-49252

**IMPORTANT: Use only factory authorized service parts and replacement filters.**

For factory authorized service, or to order factory authorized replacement parts, contact your Wells authorized service agency, or call:

### Wells Manufacturing

265 Hobson Street  
Smithville, Tennessee U.S.A.

Service Dept.

phone: (314) 678-6314

fax: (314) 781-2714

Service Parts Department can supply you with the name and telephone number of the WELLS AUTHORIZED SERVICE AGENCY nearest you.

### CUSTOMER SERVICE DATA

please have this information available if calling for service

RESTAURANT \_\_\_\_\_ LOCATION \_\_\_\_\_  
INSTALLATION DATE \_\_\_\_\_ TECHNICIAN \_\_\_\_\_  
SERVICE COMPANY \_\_\_\_\_  
ADDRESS \_\_\_\_\_ STATE \_\_\_\_\_ ZIP \_\_\_\_\_  
TELEPHONE NUMBER (\_\_\_\_) \_\_\_\_\_ - \_\_\_\_\_

EQUIPMENT MODEL NO. \_\_\_\_\_

EQUIPMENT SERIAL NO. \_\_\_\_\_

VOLTAGE: (check one)  120  208  240



Wells Bloomfield proudly supports CFESA  
Commercial Food Equipment Service Association

**SERVICE TRAINING - QUALITY SERVICE**



**CUSTOMER SATISFACTION**



**WELLS MANUFACTURING**  
265 Hobson Street, Smithville, Tennessee 37166  
telephone: 314-678-6314  
fax: 314-781-2714  
[www.wells-mfg.com](http://www.wells-mfg.com)