

WELLS MANUFACTURING

265 Hobson Street, Smithville, Tennessee 37166
telephone: 314-678-6314
fax: 314-781-2714
www.wells-mfg.com

361



WFAE-30F

OWNERS MANUAL

ELECTRIC
OPEN-FRYPOT
30# FRYER
with AUTO-LIFT

MODELS

WFAE-30F

with or without
Optional Filter Wand

WVAE-30F

(FRYER SECTION ONLY)

with or without
Optional Filter Wand

Includes
INSTALLATION
USE & CARE
EXPLODED VIEW
PARTS LIST
WIRING DIAGRAM

WARNING:

Improper installation, adjustment, alteration, service or maintenance can cause property damage, injury or death. Read the installation and operating instructions thoroughly before installing, using or servicing this equipment.

IMPORTANT: DO NOT DISCARD THIS MANUAL

This manual is considered to be part of the appliance and is to be given to the OWNER or MANAGER of the restaurant, or to the person responsible for TRAINING OPERATORS of this appliance. Additional manuals are available from your WELLS DEALER.

THIS MANUAL MUST BE READ AND UNDERSTOOD BY ALL PERSONS USING OR INSTALLING THIS APPLIANCE. Contact your WELLS DEALER if you have any questions concerning installation, operation or maintenance of this equipment.

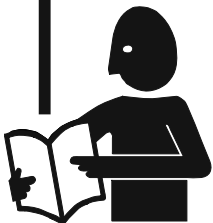

LIMITED EQUIPMENT WARRANTY

Wells Manufacturing warranties new products to be free from defects in material and/or workmanship for a period of one [1] year from the date of original installation, except as noted below. Defects that occur as a result of normal use, within the time period and limitations defined in this warranty, will at Wells' discretion have the parts replaced or repaired by Wells or a Wells-authorized service agency.

THIS WARRANTY IS SUBJECT TO ALL LISTED CONDITIONS.

Repairs performed under this warranty are to be performed by a Wells-authorized service agency. Wells will not be responsible for charges incurred or service performed by non-authorized repair agencies.

In all cases, the nearest Wells-authorized service agency must be used.

Wells will be responsible for normal labor charges incurred in the repair or replacement of a warrantied product within 50 miles (80.5 km) of an authorized service agency. Time and expense charges for anything beyond that distance will be the responsibility of the owner. All labor will need to be performed during regular service hours. Any overtime premium will be charged to the owner. For all shipments outside the U.S.A. and Canada, please see the International Warranty for specific details.

It is the responsibility of the owner to inspect and report any shipping damage claims, hidden or otherwise, promptly following delivery.

No mileage or travel charges will be honored on any equipment that is deemed portable. In general, equipment with a cord and plug weighing less than 50 lb. (22.7 kg) is considered portable and should be taken or shipped to the closest authorized service agency, transportation prepaid.

CONTACT

Should you require any assistance regarding the operation or maintenance of any Wells equipment; write, phone, fax or email our service department. In all correspondence mention the model number and the serial number of your unit, as well as the voltage or type of gas you are using.

Business hours are 8:00 a.m. to 4:30 p.m. Central Standard Time
 Telephone 314.678.6314
 Fax 314.781.2714
 Email customerservice@star-mfg.com
 www.wells-mfg.com

WARRANTY EXCLUSIONS

THE FOLLOWING WILL NOT BE COVERED UNDER WARRANTY.

- Any product which has not been installed, cleaned, maintained, or used in accordance with the directions published in the appropriate installation sheet and/or owner's manual as well as national and local codes, including incorrect gas or electrical connection. Wells is not liable for any unit which has been mishandled, abused, misapplied, subjected to chlorides, harsh chemicals, or caustic cleaners, damaged from exposure to hard water, modified by unauthorized personnel, damaged by flood, fire, or other acts of nature [or God], or which have an altered or missing serial number.
- Installation, labor, and job checkouts, calibration of heat controls, air and gas burner/bypass/pilot adjustments, gas or electrical system checks, voltage and phase conversions, cleaning of equipment, or seasoning of griddle surface.
- Replacement of fuses or resetting of circuit breakers, safety controls, or reset buttons.
- Replacement of broken or damaged glass components, quartz heating elements, and light bulbs.
- Labor charges for all removable parts in gas charbroilers and hotplates, including but not limited to burners, grates, and radiants.
- Any labor charges incurred by delays, waiting time, or operating restrictions that hinder a service technician's ability to perform service.
- Parts that fail or are damaged due to normal wear or labor for replacement of Items that can easily be replaced during a daily cleaning routine. such as but not limited to silicone belts, PTFE non-stick sheets, knobs, control labels, bulbs, fuses, quartz heating elements, baskets, racks, and grease drawers.
- Components that should be replaced when damaged or worn, but have been field-repaired instead [eg. field-welded fry pots].
- Any loss of business or profits.

ADDITIONAL WARRANTIES

Specialty/chain specific versions may also have additional and/or extended warranties.

PRODUCTS	PARTS	LABOR
universal ventless hoods	2 years	1 year
canopy hoods	2 years	1 year
"Cook'n Hold" equipment [HW10, HWSMP, LLSC7, LLSC7WA, LLSC11, and LLSC11WA]	2 years	1 year
cast iron grates, burners, and burner shields	1 year	
original Wells parts sold to repair Wells equipment	90 days	
Service First	1 year	

TABLE OF CONTENTS

WARRANTY	1
SPECIFICATIONS	1
FEATURES & OPERATING CONTROLS	2
OPTIONAL FILTER WAND	3
PRECAUTIONS & GENERAL INFORMATION	5
AGENCY LISTING INFORMATION	5
INSTALLATION	6
PREPARATION PRIOR TO OPERATION	8
OPERATION	11
MAINTENANCE INSTRUCTIONS	
FILTER OPERATION	12
DISCARDING USED OIL	15
OPTIONAL FILTER WAND	17
CLEANING	18
TROUBLESHOOTING SUGGESTIONS	20
EXPLODED VIEW & PARTS LIST	21
WIRING DIAGRAM	24
PARTS & SERVICE	25
CUSTOMER SERVICE DATA	25

INTRODUCTION

Thank You for purchasing this Wells Manufacturing appliance.

Proper installation, professional operation and consistent maintenance of this appliance will ensure that it gives you the very best performance and a long, economical service life.

This manual contains the information needed to properly install this appliance, and to use and care for the appliance in a manner which will ensure its optimum performance.

SPECIFICATIONS

DIMENSIONS	Wide	Deep	High
		15.62"	33.25"
CAPACITIES	Cooking Oil (Liquid Shortening Only)	Lbs.	Kg.
		30	14
	Chicken (Fresh)	14	6
	Chicken (Frozen)	12	5
ELECTRICAL SPECIFICATIONS			
VOLTAGE REQUIREMENTS	DOMESTIC		EXPORT (EU)
	208 VAC	240VAC	380-415V 3NAC
	NOTE: Shipped from factory 3Ø, field convertible to 1Ø		
POWER CONSUMPTION	9,000 watts	9,000 watts	9.300 watts
AMPERAGE	43.3 amps (1 Ø) 25.0 amps per leg (3Ø)	37.5 amps (1 Ø) 21.7 amps per leg (3Ø)	L1 = 14,3 amps L2 = 13,0 amps L3 = 13,0 amps N = 2,7 amps

FEATURES & OPERATING CONTROLS

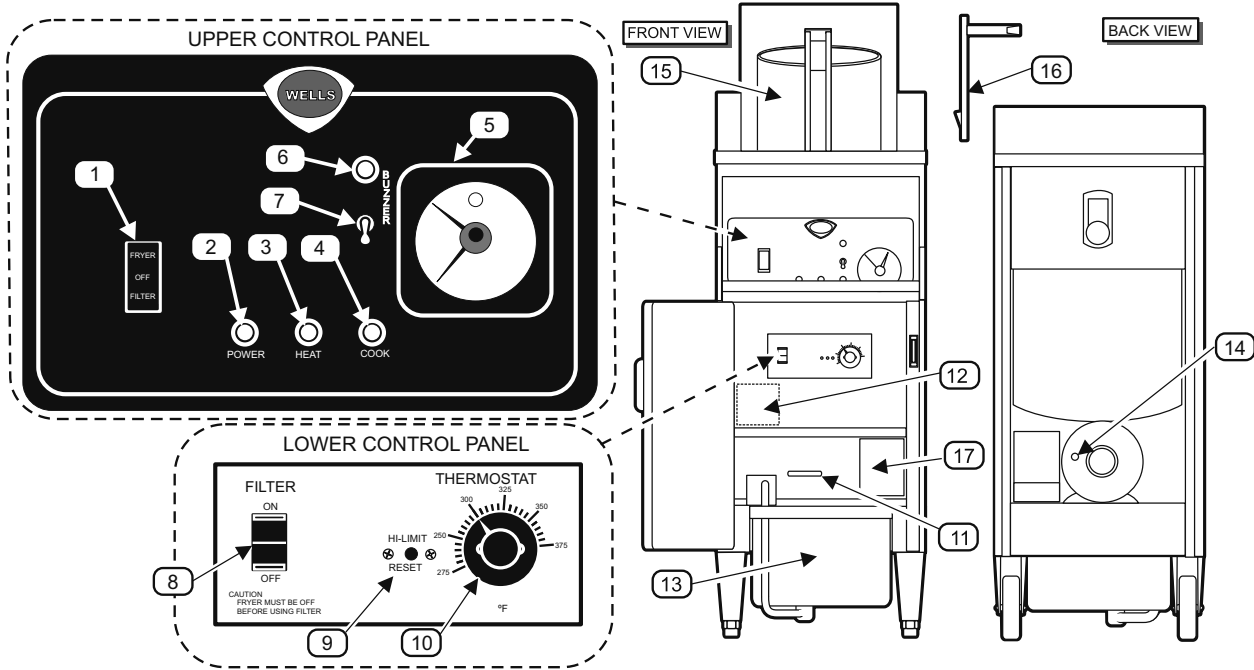

Fig. 1 WFAE-30F Features & Operating Controls

1	POWER SWITCH (FRYER-OFF-FILTER)	FRYER position energizes the FRYER and POWER LIGHT; de-energizes FILTER PUMP. HEATING ELEMENTS energized and regulate to setting on CONTROL THERMOSTAT (8).
		OFF position de-energized FRYER and FILTER PUMP.
		FILTER position de-energizes FRYER; energizes FILTER PUMP SWITCH (6).
2	POWER LIGHT (amber)	Glows to indicate FRYER is energized.
3	HEAT LIGHT (amber)	Glows to indicate HEATING ELEMENT energized; Off when oil temperature reaches setting on CONTROL THERMOSTAT (8).
4	COOK LIGHT (amber)	Glows to indicate COOK LEVER in cook position.
5	TIMER	Controls LIFT CRADLE AND BUZZER. Start TIMER by pressing red button at center of knob. Lift CRADLE will lower. Pointer indicates time remaining. When time reaches "0" BUZZER sounds and LIFT CRADLE raises.
6	BUZZER LIGHT (amber)	When lit, indicates BUZZER SWITCH (item 7) is turned ON and BUZZER CIRCUIT is active
7	BUZZER SWITCH	Activates BUZZER CIRCUIT. When ON will sound BUZZER anytime TIMER is at "0". Turn switch OFF or activate timer to silence buzzer.

FEATURES & OPERATING CONTROLS (continued)



WARNING: FIRE HAZARD / HOT OIL

The HI-LIMIT THERMOSTAT is a FIRE PROTECTION DEVICE. If tripping persists, clean debris from the space between the hi-limit bulb and the element to enhance oil flow and facilitate reset. Otherwise, contact your authorized Wells Service Agent for repairs. **DO NOT ATTEMPT TO BYPASS OR HOLD IN THE BUTTON OF THE HI-LIMIT THERMOSTAT. A SERIOUS FIRE MAY RESULT.**

8	FILTER PUMP SWITCH (ON-OFF)	ON position energizes FILTER PUMP and causes oil in RESERVOIR (10) to be pumped back into frypot.
		OFF position de-energizes FILTER PUMP.
		NOTE: POWER SWITCH (1) must be in <i>FILTER</i> position for FILTER PUMP to operate.
9	HI-LIMIT THERMOSTAT	Provides over-temperature protection by de-energizing HEATING ELEMENTS should oil temperature exceed factory pre-set limits.
10	TEMPERATURE CONTROL THERMOSTAT	Controls oil temperature. Range: 250°F (121°C) 375°F (191°C)
11	DRAIN VALVE LEVER	Opens and closes the DRAIN VALVE: Turn counterclockwise (vertical) to <i>OPEN</i> Turn clockwise (horizontal) to <i>CLOSE</i>
12	POWER OUTLET BOX	Electrical service connection TERMINAL BLOCK located here.
13	OIL FILTER RESERVOIR	Collects oil from FRYPOT for filtering or disposal. Holds filter screen, filter paper & filter paper holder.
14	FILTER PUMP MOTOR RESET BUTTON (located at rear of motor)	FILTER PUMP MOTOR is equipped with an overheating protection device. RESET must be performed manually. Allow motor to cool for approx. 30 min, then firmly press the red button.
15	FRY BASKET	Holds product to be cooked.
16	BASKET HANDLE	Used to manually raise and lower FRY BASKET into and out of FRYPOT. REMOVE FROM BASKET BEFORE ACTIVATING TIMER!
17	DRIP PAN	Collects liquids that accumulate on top of fryer.
NOT SHOWN	LIFT CRADLE (see page 8)	Lowers fry basket into frypot during cook cycle. Automatically raises from frypot at end of cook cycle
	FRYPOT COVER (see front cover)	Hinged cover. When tilted forward, rises and lowers with cradle lift. When tilted back, remains open during cook cycle
	(OPTIONAL) FILTER WAND	Wash sides of frypot, or transfer oil to disposal container. See page 4.

FEATURES & OPERATING CONTROLS (continued)

OPTIONAL FILTER WAND

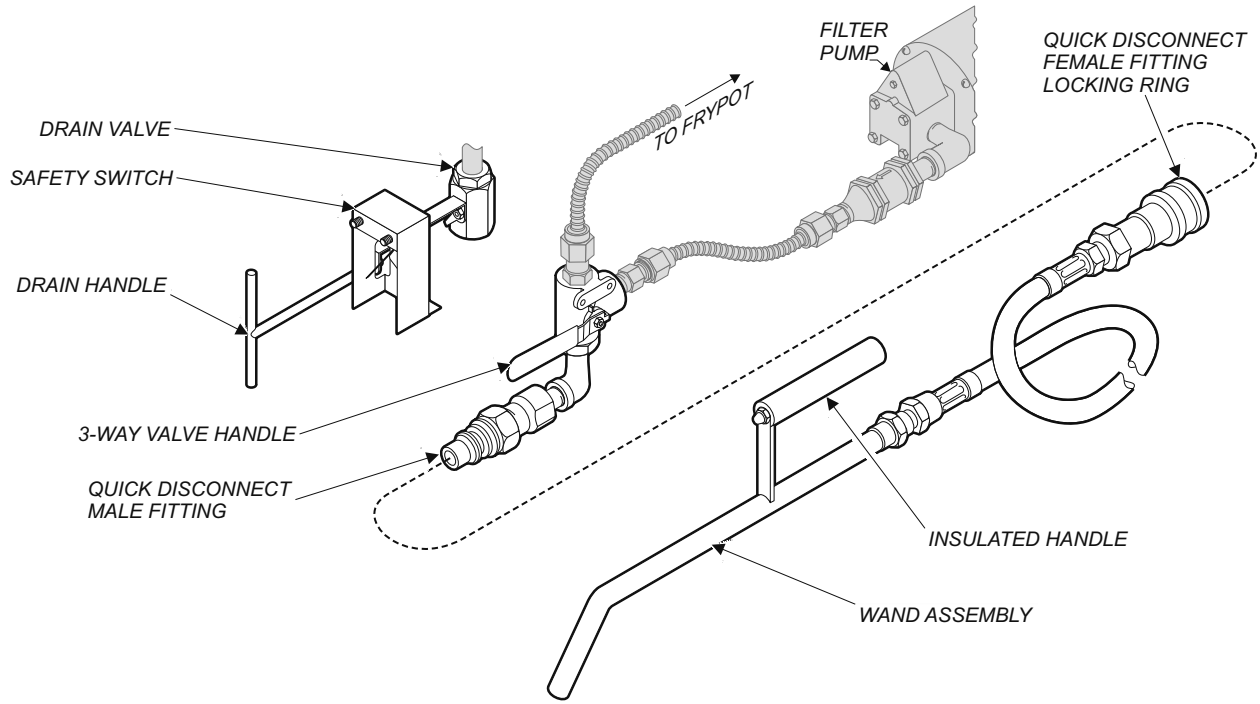

NOTE: Wand option must be ordered at time of initial build.

PRECAUTIONS AND GENERAL INFORMATION

This fryer is intended for use in commercial establishments only.

This appliance is intended to prepare food for human consumption. No other use is recommended or authorized by the manufacturer or its agents.

DO NOT open any panel that requires the use of tools for access. Live electric circuits may be exposed by opening such panels. Opening access panels must be performed by an Authorized Service Agent only. Any procedure that requires the use of tools must be performed by a qualified technician.

This appliance is equipped with an oil filtration system designed to filter hot liquid shortening only. Water, cleaning agents and/or other liquids will contaminate the oil and may damage the filter pump.

Operators of this appliance must be familiar with the appliance use, limitations and associated restrictions. Operating instructions must be read and understood by all persons using or installing this appliance.

Cleanliness of this appliance is essential to good sanitation. Read and follow all included cleaning instructions and schedules to ensure the safety of the food product.

DO NOT submerge any part of this appliance in water unless specifically instructed to do so. This appliance is not jet stream approved. DO NOT direct water jet or steam jet at this appliance, nor at any control. DO NOT splash or pour water on, in or over any controls. DO NOT wash area around this appliance with water jet. Any part which has become wet must be thoroughly dried before use.

Cooking oil will be very hot when in use. Contact will cause severe injury, and can cause blindness or death. Wear appropriate heat-protective clothing when operating or servicing this appliance.

This appliance must be operated with the supplied legs and casters properly installed.

The technical content of this manual, including any parts breakdown illustrations and/or adjustment procedures, is intended for use by qualified technical personnel only.

This manual is considered to be a permanent part of the appliance. This manual and all supplied instructions, diagrams, schematics, parts breakdown illustrations, notices and labels must remain with the appliance if it is sold or moved to another location.



**DANGER:
BURN HAZARD**

Cooking oil in this appliance operates at very high temperatures. Contact with hot oil can cause severe injury or death. Wear appropriate heat-protective clothing when operating or servicing this appliance.



**WARNING:
BURN HAZARD**

DO NOT allow water or ice to contact hot oil. DO NOT attempt to cool the oil with water or ice. The water will boil violently. Contact with splattering or foaming hot oil will cause severe burns.



**WARNING:
SLIP AND FALL
HAZARD**

Spilled cooking oil is very slippery and can cause falls. Clean up oil spills promptly.



**CAUTION:
BURN HAZARD**

Exposed surfaces can be hot to the touch and may cause burns.



**CAUTION:
HEALTH HAZARD**

Old cooking oil can be a breeding ground for bacteria. Clean and sanitize exterior surfaces of fryer regularly.

AGENCY LISTING INFORMATION

This appliance conforms to NSF Standard 4 for sanitation only if installed in accordance with the supplied *Installation Instructions* and maintained according to the instructions in this manual.

Domestic fryers are  and  listed under UL File E6070 for 208V and 240V.

Export (European) fryers comply with  standards for 380-415V 3NAC.



STD 4



E6070



INSTALLATION

NOTE: DO NOT discard the carton or other packing materials until you have inspected the appliance for hidden damage and tested it for proper operation. Refer to *SHIPPING DAMAGE CLAIM PROCEDURE* on the inside front cover of this manual.



WARNING: FIRE HAZARD

Do not store gasoline or any other flammable or combustible material near this appliance. The area where the fryer is installed must be kept clear of combustibles and flammables. This includes mops, rags, grease, wrapping paper and electric cords.

Installation and startup must be performed by a Wells Manufacturing Authorized Service Agency.

IMPORTANT:

Certain jurisdictions require fryers to be restrained with a TETHER or other approved restraint device. It is the responsibility of the installer to check with the **AUTHORITY HAVING JURISDICTION** in order to ascertain the applicability of this requirement to **THIS SPECIFIC INSTALLATION**.

Installer must complete the **WARRANTY REGISTRATION** and **FRYER CHECKOUT** form, and record the details of the particular installation on the **CUSTOMER SERVICE DATA** form in this manual.

UNPACKING & INSPECTION

Carefully remove the appliance from the carton. Remove all protective plastic film, packing materials and accessories from the appliance before connecting performing any installation procedure.

Carefully read all instructions in this manual and the *Installation Instruction Sheet* packed with the appliance before starting any installation.

Read and understand all labels and diagrams attached to the appliance.

Carefully account for all components and accessories before discarding packing materials. Store all accessories in a convenient place for later use.

COMPONENTS

- 1 ea. FILTER RESERVOIR
- 1 ea. FILTER SCREEN
- 1 ea. FILTER PAPER HOLDER
- 4 ea. OIL FILTER SUCTION TUBE O-RINGS
- 1 ea. LIFT CRADLE
- 1 ea. FRY BASKET
- 1 ea. BASKET LIFTING HANDLE
- 1 ea. WAND ASSEMBLY (if optioned)

ACCESSORIES

- 1 ea. LITERATURE PACKAGE
- 1 pk. FILTER PAPER
- 1 pk. FILTER POWDER
- 1 ea. HIGH TEMPERATURE BRUSHES
- 1 ea. CLEANOUT DOWEL (wood rod)

SETUP

It is the responsibility of the installer to verify that this fryer installation is in compliance with local code authorities and with the specifications listed in this manual.

Certain local or state codes require fryers to be restrained with a tether or other approved restraint device. It is the responsibility of the installer to check with the authority having jurisdiction, in order to ascertain the applicability of this requirement to this specific fryer installation.

Setup the fryer only on a firm, level, non-combustible surface. Verify local codes for requirements. Concrete, tile, terrazzo or metal surfaces are recommended. Metal or tile over combustible material may not meet code for non-combustible surfaces.

Verify that the unit sits firmly **ON BOTH CASTERS AND BOTH LEGS**. With the adjustable legs, adjust as required to level the appliance. Both legs and both casters must be adjusted to firmly contact the floor in order to prevent tipping.

Refer to the *Installation Instruction Sheet* for required clearances. Maintain required clearances between the appliance and adjacent combustible surfaces.

INSTALLATION (continued)

ELECTRICAL INSTALLATION

Refer to the nameplate on the front of the fryer and to the specifications listed on page 1 of this manual. Verify that electric service voltage, phase and amperage capacity meet or exceed these specifications.

US and Canadian Units Only:

Field wiring must be no less than 12 ga. Solid copper wire, rated for at least 75°C.

EU Units Only:

- Supply cords shall be oil-resistant, sheathed flexible cable not lighter than ordinary polychloroprene or other equivalent synthetic elastomer-sheathed cord (code designation 245 IEC 57) or approved metal conduit connection.
- Supply power wire must not exceed 2 m between the point where cord or cord guard enters the appliance and the entry to the plug.
- Minimum cross-sectional area of conductors shall not be less than 2.5 mm².

Fryers are shipped from the factory wired for 3Ø. Verify that field wiring conforms to the *Three-Phase Wiring Diagram* included with the fryer.

NOTE: Fryers are FIELD-CONVERTIBLE TO 1Ø. For single-phase operation refer to the *3-phase to 1-phase Instructions* included with the fryer. Verify that both internal wiring and field wiring conforms to the *Single-Phase Wiring Diagram* included with the fryer.

NOTE: Supplied strain relief is intended for use with metallic conduit. For flexible power cords, electrical installer must supply an appropriate approved strain relief fitting.

INSTRUCTIONS

1. Using a screwdriver, remove terminal block access panel located behind front door marked "NOTICE - REMOVE THIS PANEL FOR TERMINAL BLOCK".
2. Knock out the appropriate hole plug located on enclosure panel, and connect conduit strain relief.
3. Thread supply leads through strain relief. Connect power leads to terminals marked "L1", "L2", "L3". On EU units, connect neutral lead to terminal marked "N".
4. Connect green-with-yellow-trace lead to ground lug marked .
5. Secure all connections and reinstall terminal access cover.

IMPORTANT:

Field wiring must be routed and secured away from the FRYPOT, TUBING and FILTER PUMP MOTOR. Field wiring must be configured to allow access to the rear of fryer for cleaning and access to the filter pump motor RESET BUTTON.

6. **On EU units:** Equal potential grounding screw is located at rear of frame assembly, marked .

Remove screw and secure an appropriate grounding wire with terminal.

IMPORTANT:

Electric installation of this appliance must be performed by a licensed electrician. Installation must conform to the requirements of local codes and ordinances, as well as to the requirements of the National Electrical Code.

IMPORTANT:

This installation instruction has been prepared for personnel authorized, qualified, certified or licensed to install electrical equipment, who should perform the initial start-up and adjustments covered in this manual.

IMPORTANT:

Verify the incoming voltage matches unit nameplate specifications. Wiring this appliance to voltage other than as specified can cause severe damage to the appliance, or will result in degraded performance.

IMPORTANT (EU only):

An approved all-pole power disconnect switch with at least 3mm contact gap, must be supplied and installed in the fixed wiring in an accessible location (close proximity to the appliance) by a licensed electrician.

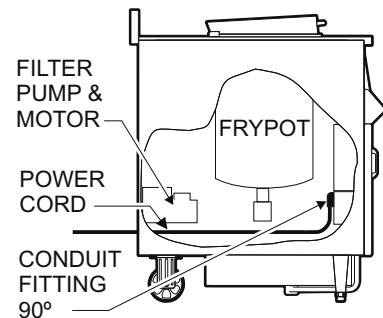

Fig. 2 Field Wiring

PREPARATION PRIOR TO OPERATION



WARNING: BURN HAZARD

TURN THERMOSTAT TO LOWEST TEMPERATURE SETTING
(FULLY COUNTERCLOCKWISE)

USE ONLY LOW-FOAMING COMMERCIAL FRYER CLEANSER.
CAREFULLY FOLLOW CLEANSER INSTRUCTIONS AND WARNINGS.

DO NOT LEAVE FRYER UNATTENDED
WHILE BOILING OUT FRYPOT.

WHEN WATER BEGINS FOAMING,
BE PREPARED TO TURN POWER SWITCH OFF.

Boiling water and splatter can result in moderate to serious injury.

Prior to leaving the factory, each fryer is tested for proper operation. Oil residue must be cleaned from the frypot before filling it with fresh oil.

IMPORTANT:

Use a LOW-FOAMING COMMERCIAL fryer cleanser only.

PRE-CLEANING PROCEDURE

Press POWER SWITCH OFF.

Close DRAIN VALVE (lever horizontal).
Fill FRYPOT with 4 gallons of cold water.

Press POWER SWITCH to *FRYER*.

When water comes to a full boil, press POWER SWITCH OFF. When boiling ceases, slowly add and stir in the *LOW FOAMING COMMERCIAL FRYER CLEANSER*. Using the *HIGH TEMPERATURE BRUSH* supplied with the fryer, stir until the cleanser is completely dissolved.

Press POWER SWITCH to *FRYER*. When the water begins to boil, press POWER SWITCH OFF. When the boiling subsides, again press POWER SWITCH to *FRYER*. Repeat this procedure continuously for five (5) minutes.

Press POWER SWITCH OFF. Allow the solution to cool to 120°F or less.

Place a suitable METAL container under the DRAIN VALVE. Open DRAIN VALVE (lever vertical) to drain the cleaning solution. **NOTE:** Drain no more than 4" at a time into the container to prevent splashing and spilling. Dispose of used solution as required by local ordinances.

Rinse frypot with clean water. Dry with a soft clean cloth.

Wash LIFT CRADLE in a dishwasher. Be sure cradle is completely dry, then install LIFT CRADLE onto CRADLE LIFT ROD.

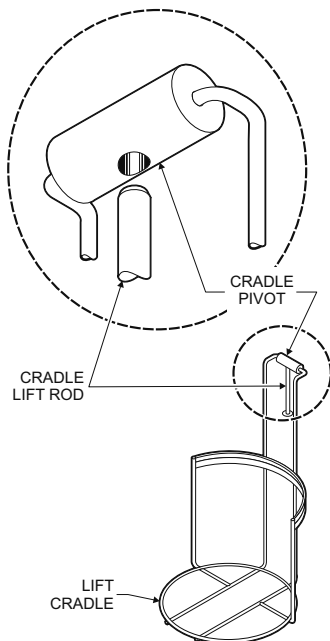

PREPARATION PRIOR TO OPERATION (continued)

PREPARE FILTER RESERVOIR

Install SUCTION TUBE O-RINGS, FILTER PAPER and FILTER PAPER HOLDER into RESERVOIR.

Install assembled FILTER RESERVOIR in place at bottom of FRYER.

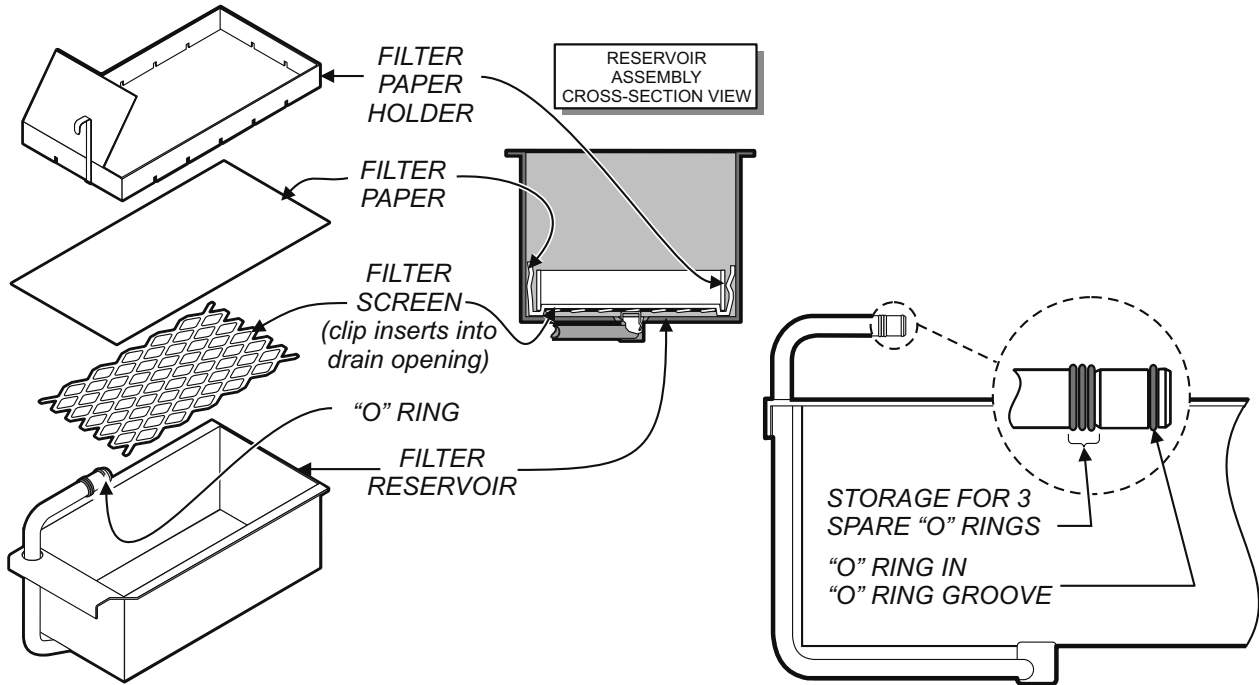

WARNING: SLIP/FALL HAZARD

DO NOT OPERATE UNLESS DRIP PAN IS INSTALLED.

Oil will drip on the floor and slips/falls will result.
Death or serious injury may result from slipping and falling in spilled oil.

Install DRIP PAN (item 17) into mounting bracket behind fryer door.



WARNING: SLIP/FALL HAZARD

CLOSE DRAIN VALVE BEFORE FILLING WITH OIL.

Unless drain valve is closed, oil poured into kettle will drain into reservoir or onto the floor. Oil spill may occur.
Death or serious injury may result from slipping and falling in spilled oil.

Close DRAIN VALVE (item 11) by turning lever to horizontal position.

PREPARATION PRIOR TO OPERATION (continued)

NOTE:

Fill frypot with 30 lbs of LIQUID SHORTENING ONLY.

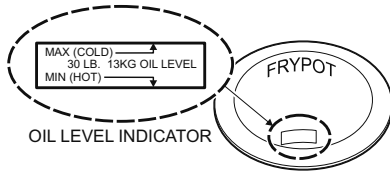

Fill the FRYPOT to the *COLD (MAX)* line on OIL LEVEL INDICATOR with room temperature commercial-quality LIQUID SHORTENING. This requires 30lbs. of oil.

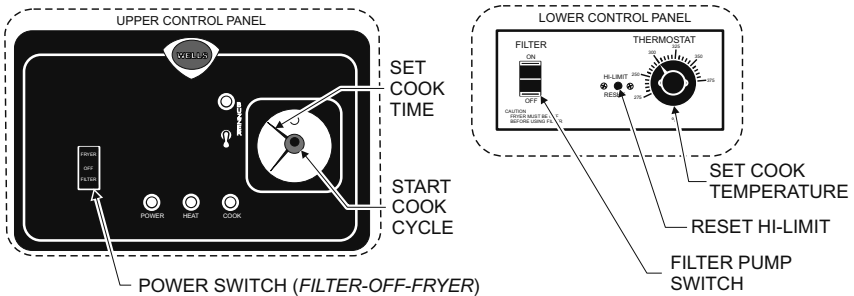

DO NOT USE

- SOLID SHORTENING
- LARD

Solid shortening will solidify in the filter reservoir and filter pump rendering the filtration system inoperable.

Damage caused the use of anything other than liquid shortening is **NOT COVERED BY WARRANTY.**

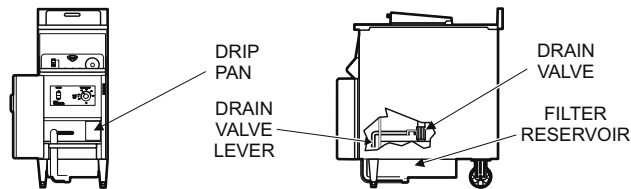

Check operation of FRYER and all CONTROLS.



WARNING: OIL SPLATTER HAZARD

The weight of product that can safely be cooked in this pressure fryer will vary with oil level, product moisture content and oil temperature.

**FAILURE TO DETERMINE THE SAFE WEIGHT OF PRODUCT WILL RESULT IN HOT OIL RELEASE FROM THE FRYER
HOT OIL WILL CAUSE SEVERE BURNS ON CONTACT**

Death or serious injury may result from slipping and falling in spilled oil.

IMPORTANT:

For operational safety it is important to determine the maximum load weight for the specific operation:

- Start with small loads
- Gradually increase load size
- Determine the largest load that will allow a full cook cycle without oil foaming out of the frypot.
- Post the maximum load in a conspicuous spot near the fryer.

DETERMINE MAXIMUM LOAD WEIGHT:

For operational safety, it is very important to determine the maximum load weight for the specific operation. This can be accomplished by starting out with small loads and *gradually increasing to the largest load size that will allow a cook cycle to be completed without oil foaming out of the FRYPOT.*

PRE-HEATING FRYER

Make sure FRYPOT is filled with *30 LB. of cooking oil.*

Open door and set THERMOSTAT (item 10) to desired cooking temperature. **CLOSE THE DOOR.**

Set POWER SWITCH (item 1) to *FRYER*. POWER LIGHT (item 2) and HEAT LIGHT (item 3) will glow. HEAT LIGHT will cycle on and off with the HEATING ELEMENTS. When HEAT LIGHT first goes off, fryer is ready to cook the product.

SET COOK TIMER AND LOAD PRODUCT

Set TIMER (item 5) to desired cooking time.

FROZEN PRODUCT:

Load frozen product into BASKET. Using the BASKET HANDLE (item 16) set BASKET on LIFT CRADLE.

IMPORTANT: REMOVE HANDLE.

Press RED BUTTON on TIMER to lower BASKET into FRYPOT.

FRESH PRODUCT:

Using BASKET HANDLE, set BASKET on LIFT CRADLE.

IMPORTANT: REMOVE THE HANDLE.

Press the red button on TIMER to lower BASKET into FRYPOT.

Manually drop each piece of fresh product into hot oil, just above the oil level to minimize splattering.

ALWAYS USE PROTECTIVE EQUIPMENT, SUCH AS INSULATED GLOVES, TO PROTECT AGAINST HOT OIL BURNS

COOK CYCLE AND BUZZER

When an audible alarm is desired at end of cook cycle, turn BUZZER SWITCH (item 7) *ON* after TIMER has been started. BUZZER LIGHT (item 6) will glow.

Note: If BUZZER SWITCH is turned *ON* before BASKET is lowered, BUZZER will sound until BASKET has fully lowered.

At end of cook cycle, BASKET will raise and BUZZER will sound until BUZZER SWITCH is turned *OFF*, or until the next cook cycle is started.

Use BASKET HANDLE (item 16) to remove basket of cooked product from LIFT CRADLE. Serve or dispense cooked product as required.



CAUTION: BURN HAZARD

Hot oil can cause serious burns on contact. Wear appropriate protective clothing when using this fryer.

IMPORTANT:

Always remove basket handle from basket before lowering lift cradle.

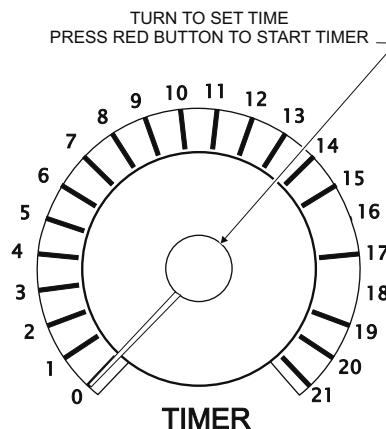

MAINTENANCE - FILTER OPERATION



WARNING: BURN HAZARD

HOT OIL SPILL OR SPLATTER

DO NOT REMOVE FILTER RESERVOIR WHEN IT CONTAINS HOT OIL
HOT OIL WILL CAUSE SEVERE BURNS ON CONTACT
PROTECTIVE CLOTHING AND GLOVES MUST BE WORN
DURING THE FILTERING PROCESS

Death or serious injury may result from contact with, or slipping and falling in, spilled oil.



WARNING: BURN HAZARD

DO NOT REMOVE FILTER RESERVOIR IF IT IS HOT
WEAR PROTECTIVE GLOVES OR
ALLOW RESERVOIR TO COOL BEFORE REMOVING

Oil will rapidly heat the reservoir. Serious burns can result from touching the filter reservoir with bare hands.

IMPORTANT:

Replace filter paper after each day's filtration, or as needed to return oil promptly to kettle.

IMPORTANT:

Crumbs and other debris left in the filter reservoir can prevent filter paper from sealing to bottom of reservoir completely. This will cause incomplete filtration.

FILTER PAPER INSTALLATION

1. Open FRYER DOOR and remove FILTER RESERVOIR.
2. Remove FILTER PAPER HOLDER, used FILTER PAPER and FILTER SCREEN. Discard used filter paper and make sure filter reservoir, filter screen and filter paper holder are clean and dry.
3. Install FILTER SCREEN in reservoir with spring clip on screen pressed firmly into drain hole, and aligned parallel to sides of reservoir. See diagram, page 9.
4. Place a NEW SHEET of filter paper on reservoir, with edges of the paper evenly overhanging reservoir flanges.
5. Center FILTER PAPER HOLDER over filter paper, then press firmly into reservoir. Make sure filter paper holder rests firmly on reservoir bottom, with paper protruding evenly up all sides.
6. Inspect O-RING on FILTER SUCTION TUBE for damage. Replace o-ring if it is scuffed, cut or cracked. Spare o-rings are stored midway on the top portion of the suction tube.
7. Install filter reservoir assembly into fryer. Make sure o-ring closest to end of suction tube is firmly seated in SUCTION LINE RECEPTACLE.

MAINTENANCE - FILTER OPERATION (continued)

FILTERING OIL

NOTE: For operation of optional filter wand, see page 16.

NOTE:

Oil should be at least 300°F (149°C) DO NOT attempt to filter cold oil. DO NOT attempt to pump oil when less than 300°F. Cold oil will not pass through the filter paper. Filtering cold oil will result in the premature failure of the filter pump. Damage as a result of pumping cold oil IS NOT COVERED BY WARRANTY.

NOTE:

DO NOT store oil in the reservoir for any extended period, including overnight.

IMPORTANT:

The filtration system in your Wells Fryer is designed to filter hot liquid shortening ONLY. Water, cleaning agents or other liquids will damage the filter pump and may contaminate the food product

1. Press POWER SWITCH (item 1) to *FILTER*. Pump controls will be energized and heating elements are de-energized.
2. Remove and examine filter reservoir:
 - Verify that a serviceable sheet of filter paper is properly installed.
 - Verify that an o-ring is in place and in good condition. Reinstall reservoir, making sure the SUCTION TUBE is firmly seated in the SUCTION RECEPTACLE.
3. Press FILTER PUMP SWITCH (item 8) to *ON* to start filter pump.
4. Slowly rotate DRAIN VALVE LEVER (item 11) to the vertical position. Oil will drain from the frypot and into the reservoir. The filter pump will draw oil through the filter paper and return it to the frypot.

IMPORTANT:

DO NOT leave the fryer unattended during the filtering process. Continuously monitor oil level in the reservoir to avoid overflowing the reservoir and spilling oil on the floor. Be prepared to turn the drain valve lever clockwise to stop or regulate the flow of oil to the reservoir.

5. Carefully and slowly add the contents of one package of FILTER POWDER to the oil in the frypot. Sprinkle the filter powder onto the surface of the oil at the point where it is being drawn down the drain and into the filter reservoir.

(CONTINUED ON PAGE 14)



CAUTION
BURN HAZARD

Protective clothing and gloves must be worn during the filtering process



CAUTION
BURN HAZARD

Filter reservoir may be hot. Wear insulated gloves, or allow reservoir to cool, before touching it.

IMPORTANT:

Filtering cooking oil helps to ensure the quality of the food product. Careful observation of the finished food product will help you determine the optimal filtering frequency. (Example: Filter the oil after each six loads of fresh breaded chicken)

FILTER POWDER absorbs acids and many other contaminants in the cooking oil, allowing the oil to be used longer before it must be replaced. Wells Flavor Saver Oil Filter Powder is available from your Wells Equipment Dealer or Authorized Service Agent in a case of 45 packages (p/n 22410).

NOTE: On fryers equipped with optional FILTER WAND, oil stream from the wand may be directed at the sides of the frypot to wash down crumbs and cooking debris. See page 16.

MAINTENANCE - FILTER OPERATION (continued)



WARNING: BURN HAZARD

WEAR PROTECTIVE CLOTHING AND INSULATED GLOVES WHEN CLEANING FRYPOT WITH HI-TEMP BRUSH AND WHEN CLEARING DRAIN WITH WOOD CLEANOUT DOWEL.

Frypot and oil will be hot. Hot oil may splatter. Contact with hot oil can cause serious injury

NOTE:

Use the provided WOOD DOWEL to clear clogs in the frypot drain. Push dowel down through drain hole in the front center of the frypot..

IMPORTANT:

Verify that all oil has been returned to frypot at end of filtering cycle.

IMPORTANT:

Crumbs and other debris left in the filter reservoir can prevent filter paper from sealing to bottom of reservoir completely. This will cause incomplete filtration.

IMPORTANT:

Avoid contaminating the oil or food product by verifying that all components of filter reservoir assembly are completely dry before reassembling.

(CONTINUED FROM PAGE 13)

6. Brush down sides and bottom of frypot using provided hi-temperature brush. Loosen crumbs and other debris to flush them into filter reservoir.
7. Rotate DRAIN VALVE LEVER (item 11) to the horizontal position when filtering is complete,
8. Observe the oil returning to frypot. When bubbles appear, wait approximately 15 seconds, then press FILTER PUMP SWITCH to *OFF*.
9. Press POWER SWITCH to either:
 - a. *FRYER* position to resume cooking; or,
 - b. *OFF* position to service filter or shut-down fryer.

FILTER SERVICE - REPLACE FILTER PAPER

IMPORTANT:

Service filter and replace filter paper after each day's filtration, or as needed to promptly return oil to frypot.

1. Allow FILTER RESERVOIR to cool. Remove reservoir from fryer and disassemble.
2. Dispose of used filter paper as required by local ordinances.
3. Clean FILTER RESERVOIR, FILTER SCREEN and FILTER PAPER HOLDER in the dishwasher, or use warm water with a mild detergent. Be sure all components are thoroughly dry, then reassemble reservoir using a fresh sheet of filter paper.

MAINTENANCE - DISCARDING USED OIL



WARNING: BURN HAZARD

OIL MUST COOL TO BELOW 120°F (49°C)
BEFORE DRAINING OIL FROM FRYER FOR DISPOSAL
Normal operating temperature of the fryer is 375°F (191°C)
Contact with hot oil can cause serious injury



WARNING: SLIP AND FALL HAZARD

DO NOT USE FILTER RESERVOIR TO DISCARD OIL
USE A METAL CONTAINER TO COLLECT OIL FOR DISPOSAL
DO NOT FILL DISPOSAL CONTAINER MORE THAN ½ FULL
Do not leave fryer unattended when draining oil
Oil spills may occur

Death or serious injury may result from contact with, or slipping and falling in, spilled oil.



WARNING: BURN HAZARD

DO NOT REMOVE FILTER RESERVOIR IF IT IS HOT
WEAR PROTECTIVE GLOVES OR
ALLOW RESERVOIR TO COOL BEFORE REMOVING
Oil will rapidly heat the reservoir. Serious burns can result
from touching the filter reservoir with bare hands.

DISCARDING USED OIL

NOTE: To use optional wand for discarding used oil, see page 16.

1. Press POWER SWITCH to OFF. Allow oil to cool to 120°F (49°C) or less before attempting to drain oil from fryer.
2. Remove FILTER RESERVOIR ASSEMBLY. With a suitable METAL container under DRAIN VALVE, slowly rotate DRAIN VALVE LEVER to the vertical position. Fill the container no more than 4" (100mm) deep.
3. Move the DRAIN VALVE LEVER to the horizontal position.
4. Carefully remove container from under fryer. Dump used oil into your WASTE OIL CONTAINER. Repeat steps 2 & 3 until frypot is empty.
5. Be sure DRAIN VALVE LEVER is in the CLOSED (horizontal) position when finished.
6. Service FILTER RESERVOIR ASSEMBLY and reinstall .

IMPORTANT NOTE:

These instructions for discarding used oil may be disregarded if you are using WELLS MOBILE OIL CADDY WOC-1 (p/n 22470).

The WAOC-1 is a manual oil pump/removal system that allows you to pump used oil directly into the caddy, and then to pump the used oil into your oil disposal container simply by reversing pump direction.

REMEMBER:

Always follow the directions provided with the caddy. WAOC-1 is designed to handle COLD oil. Always, and without fail, allow the oil to cool to 120°F or less prior to pumping. **HOT OIL WILL BURN YOU!**

MAINTENANCE - OPTIONAL FILTER WAND OPERATION

DANGER

DANGER: BURN HAZARD

Contact with hot oil will cause severe burns.

Always wear protective clothing and heat resistant gloves when using the oil wand.

IMPORTANT:

Be sure the wand is properly installed, and that the discharge nozzle of the oil wand is directed either:

into the frypot, or
into the disposal container, before pressing the FRYER-OFF-FILTER switch to the FILTER position.



CAUTION: BURN HAZARD

Contact with hot oil may cause burns. DO NOT fill fryer beyond MAX OIL line on frypot.

For disposal of oil use only a container specifically designed for the disposal of hot oil.

DO NOT fill hot oil disposal container beyond MAX OIL line.

NOTE:

If the discharge from the nozzle is not a steady stream, the filter is clogged with breading and/or filter powder:

- Close the frypot drain valve by turning the drain valve handle to the *horizontal* position. When all oil is returned to the frypot, press the FRYER-OFF-FILTER to *OFF*.
- Allow the filter reservoir to cool. Refer to the Operation Manual for instructions on cleaning the filter and filter reservoir.

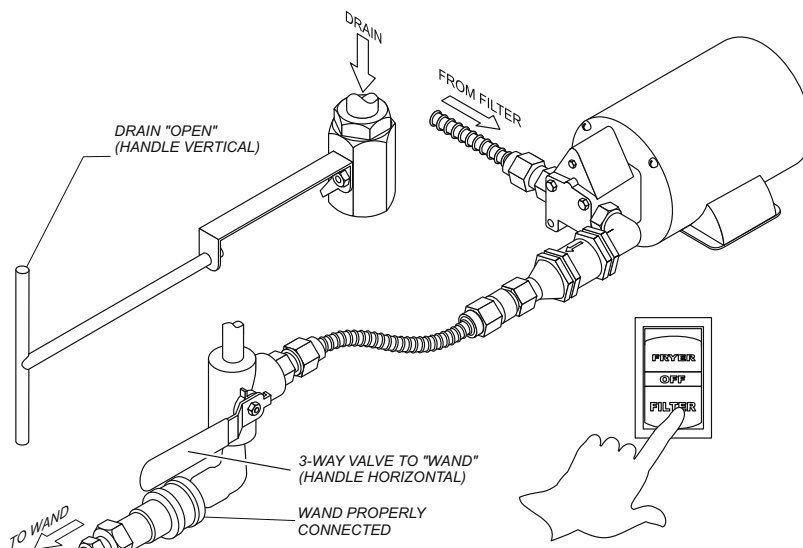

OPTIONAL OIL WAND WASH OUT FRYPOT or DISCARD OIL

- If discarding oil, be sure a suitable hot oil disposal container is available. Otherwise, prepare filter reservoir pan for filtering (see page 12).
- Turn DRAIN VALVE HANDLE *vertical* to open the drain and fill filter reservoir.
- Connect wand (female) fitting to the fryer (male) fitting:
 - Slide locking ring of wand female fitting fully toward the hose.
 - Seat wand fitting fully onto fryer fitting.
 - Allow locking ring to return to its original position.
 - Check to verify that wand fitting is held securely by pulling on the hose. It must NOT "pop" off of fitting.
- Turn 3-WAY VALVE HANDLE to *horizontal* position to direct the pump output to wand.
- Direct discharge nozzle of wand into the frypot, or into a suitable hot oil disposal container. DO NOT fill beyond the MAX OIL line.
- Press FRYER-OFF-FILTER switch to *FILTER* position.
- Wand may be used to wash down sides of the frypot during filtering, or to pump oil into a container for disposal.

MAINTENANCE - OPTIONAL FILTER WAND OPERATION (continued)

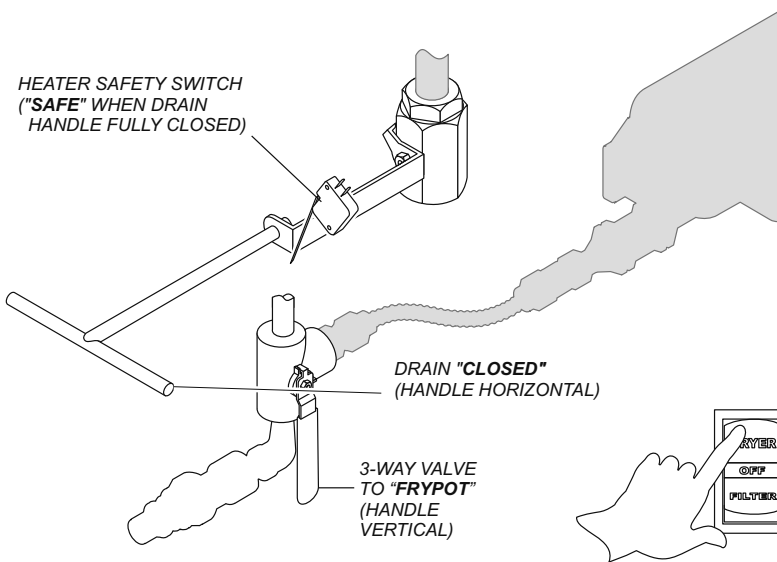

OPTIONAL OIL WAND RETURN FRYER TO NORMAL OPERATION

1. After washing down frypot, turn DRAIN VALVE HANDLE *horizontal* to close the frypot drain.
IMPORTANT: Drain handle must be fully closed in order to activate HEATER SAFETY SWITCH. Drain handle must be horizontal before for fryer heating element can be energized.
2. At conclusion of use, press FRYER-OFF-FILTER switch to *OFF* position, disconnect wand from fryer fitting and return handle of the 3-WAY VALVE to the vertical position.
3. Drain any remaining oil in wand by pointing discharge nozzle of wand down into frypot or disposal container.
4. Be sure 3-WAY VALVE HANDLE is *vertical*. Press FRYER-OFF-FILTER switch to *FILTER* position. When all oil has been returned to frypot, press FRYER-OFF-FILTER switch to *FRYER* position to resume operation, or to *OFF* position to shut down.

DANGER

DANGER: BURN HAZARD

Contact with hot oil will cause severe burns. Always wear protective clothing and heat resistant gloves when operating the fryer.



CAUTION: BURN HAZARD

Overflow of hot oil may cause burns. DO NOT fill fryer beyond MAX OIL line on frypot.

IMPORTANT:

When refilling the frypot, be sure the 3-way valve handle is *vertical*, and the drain valve handle is *horizontal* before pressing FRYER-OFF-FILTER switch to the *FILTER* position.

MAINTENANCE - CLEANING INSTRUCTIONS

DANGER

DANGER: BURN HAZARD

Contact with hot oil will cause severe burns. Allow the fryer to cool before cleaning. Always wear protective clothing and heat resistant gloves when cleaning the fryer.



CAUTION: ELECTRIC SHOCK HAZARD

Disconnect fryer from electric power before cleaning.



CAUTION: BURN HAZARD

Allow fryer to cool completely before cleaning.

IMPORTANT: DO NOT spill or pour water into controls, control panel or wiring.

IMPORTANT: DO NOT use steel wool or abrasive cleansers for cleaning the fryer cabinet or frypot.

PREPARATION

Press POWER SWITCH to *OFF*
Allow fryer to cool completely before cleaning
Disconnect fryer from electric power before cleaning

FREQUENCY

Daily, or as needed

TOOLS

Mild Detergent, Non-abrasive cleanser
Soft Cloth or Sponge, Plastic Scouring Pad

DAILY CLEANING

1. Press POWER SWITCH to *OFF*.
2. Remove FRY BASKET, LIFT CRADLE and FILTER RESERVOIR ASSEMBLY.

IMPORTANT: Clean reservoir only when empty.

3. Allow the oil to cool to a safe temperature (120°F or less).
4. Fry basket and lift cradle may be washed in a dishwasher, or with warm water and mild detergent. Rinse thoroughly and dry completely.
5. Clean FILTER RESERVOIR, FILTER SCREEN and FILTER PAPER HOLDER in the dishwasher, or use warm water with a mild detergent. Be sure all components are thoroughly dry, then reassemble reservoir using a fresh sheet of filter paper.

IMPORTANT: Be sure inside of RESERVOIR SUCTION TUBE is completely dry.

6. Keep all exterior surfaces free from splashed grease by wiping with a clean cloth dampened with warm water and mild detergent.
 - Clean both exterior and interior of FRYPOT COVER.
 - Clean side, front and accessible interior areas of cabinet.
 - A non-abrasive detergent and plastic scouring pad may be used for stubborn deposits.
 - Dry with a soft clean cloth.

IMPORTANT: DO NOT use steel wool or abrasive cleansers as these will damage the surface finish.

IMPORTANT: DO NOT spill or pour water into controls, control panel or wiring. Damage to internal components will occur.

7. Reinstall FRY BASKET, LIFT CRADLE and FILTER RESERVOIR ASSEMBLY.

Procedure is complete.

MAINTENANCE - CLEANING INSTRUCTIONS (continued)



WARNING: BURN HAZARD

TURN THERMOSTAT TO LOWEST TEMPERATURE SETTING
(FULLY COUNTERCLOCKWISE)

USE ONLY LOW-FOAMING COMMERCIAL FRYER CLEANSER.
CAREFULLY FOLLOW CLEANSER INSTRUCTIONS AND WARNINGS.

DO NOT LEAVE FRYER UNATTENDED
WHILE BOILING OUT FRYPOT.

WHEN WATER BEGINS FOAMING,
BE PREPARED TO TURN POWER SWITCH OFF.

Boiling water and splatter can result in moderate to serious injury.

PREPARATION Drain oil from fryer before cleaning

FREQUENCY Monthly, or as needed

TOOLS Low-foaming commercial fryer cleanser
Metal disposal container

IMPORTANT:

Use a LOW-FOAMING
COMMERCIAL fryer cleanser
only.

IMPORTANT:

DO NOT press FILTER PUMP
SWITCH to ON with anything
other than shortening in the
filter reservoir. Water and/or
cleaning chemicals can:

- cause severe oil splatter
- damage the filter pump
- contaminate cooking oil
and food product.

FRYPOT CLEANING - HOT BOILOUT PROCEDURE

Raise FRYPOT COVER (if closed). Press POWER SWITCH OFF.

Close DRAIN VALVE (lever horizontal). Fill FRYPOT with 4 gallons of cold water.

Press POWER SWITCH to FRYER.

When water comes to a full boil, press POWER SWITCH OFF. When boiling ceases, slowly add and stir in the LOW FOAMING COMMERCIAL FRYER CLEANSER. Using the HIGH TEMPERATURE BRUSH supplied with the fryer, stir until the cleanser is completely dissolved.

Press POWER SWITCH to FRYER. When the water begins to boil, press POWER SWITCH OFF. When the boiling subsides, again press POWER SWITCH to FRYER. Repeat this procedure continuously for five (5) minutes.

Press POWER SWITCH OFF. Allow the solution to set for thirty (30) minutes.

Allow solution to cool to 120°F (49°C) or less before draining.

Place a suitable METAL container under the DRAIN VALVE. Open DRAIN VALVE (lever vertical) to drain the cleaning solution.

NOTE: Drain no more than 4" at a time into the container to prevent splashing and spilling. Dispose of used solution as required by local ordinances.

Rinse frypot with clean water. Dry with a soft clean cloth.

TROUBLESHOOTING

SYMPTOM	POSSIBLE CAUSE	SUGGESTED REMEDY
Fryer will not heat	Unit disconnected from electric power	Reconnect to power Check/reset circuit breaker
	Temp control thermostat (item 10) not set	Set thermostat to desired temperature
	Hi-Limit thermostat (item 9) tripped	Allow unit to cool, reset hi-limit See page 3
	Fryer safety switch not made (fryer with optional wand only)	Be sure drain lever is horizontal
	Internal damage	Contact your Authorized Wells Service Agency for repairs
Lift cradle will not lower	Timer not set or not activated	Set timer to other than "0", press red button to lower cradle.
	Internal damage or mis-adjustment	Contact your Authorized Wells Service Agency for repairs
Lift cradle will not raise	Lift cradle not properly assembled to lift rod	Properly assemble cradle pivot to lift rod
	Internal damage or mis-adjustment	Contact your Authorized Wells Service Agency for repairs
Filter pump will not run or pump overload trips frequently	Switches not set for filtering	Press power switch (item 1) to <i>FILTER</i> Press pump filter switch (item 6) to <i>ON</i>
	Pump overload (item 9) tripped	Reset overload. Press red button until it "clicks" and stays locked in
	(Fryer with optional wand only) 3-way valve not in "frypot" position	Be sure valve is in "frypot" position, or that valve is in "wand" position with wand fully seated in quick disconnect fitting.
	Internal damage (pump overload trips frequently)	Contact your Authorized Wells Service Agency for repairs
Filter reservoir overflows during filter cycle	Drain valve (item 11) not properly set	Oil level in reservoir must be manually monitored at all times while filtering. Adjust flow by opening or closing drain valve
	Filter paper surface clogged with crumbs or other cooking debris	Turn drain valve <i>OFF</i> . When bubbles begin appearing in frypot turn filter pump switch <i>OFF</i> . Carefully slide reservoir out 6" and clear surface of filter paper with hi-temp brush or wooden dowel. Reinstall reservoir and resume filtering.
Filter pump won't pump, or pumps air when filtering	Suction tube not seated, allowing air to enter system	When inserting filter reservoir be sure suction tube is fully seated in suction line receptacle.
	Suction tube o-ring damaged	Replace o-ring
	Internal damage	Contact your Authorized Wells Service Agency for repairs

NOTE: There are no user serviceable components in the fryer. In all cases of damage or malfunction, contact your Authorized Wells Service Agency for repairs.

EXPLODED VIEW & PARTS LIST

WFAE-30F CABINET COMPONENTS

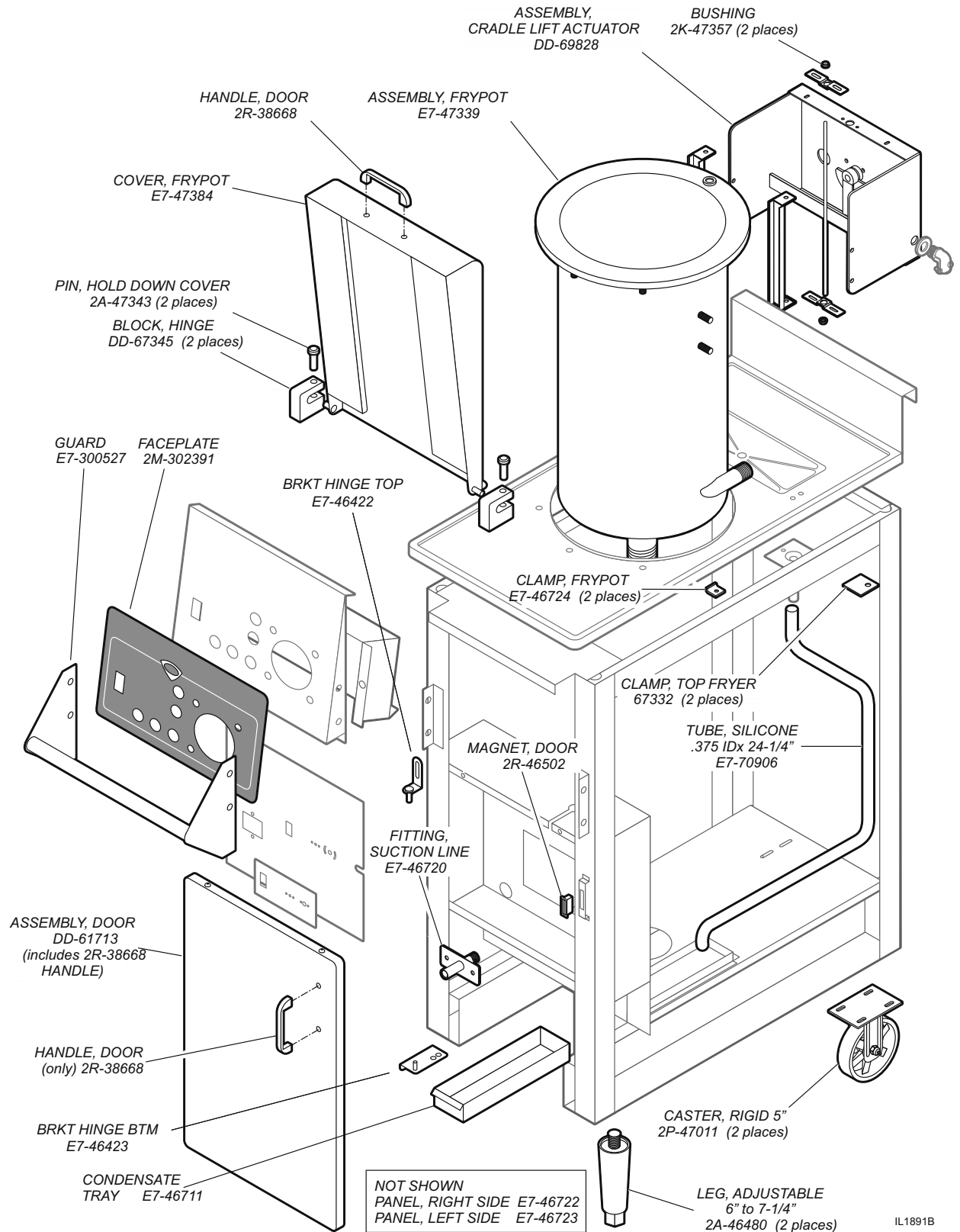

361 2M-301669 Owners Manual WFAE-30F Free-Standing 30# Electric Fryer

IL1891B

EXPLODED VIEW & PARTS LIST

LIFT ACTUATOR & MOTOR ASSEMBLY & HEATING ELEMENTS & ELECTRICAL CONTROL COMPONENTS

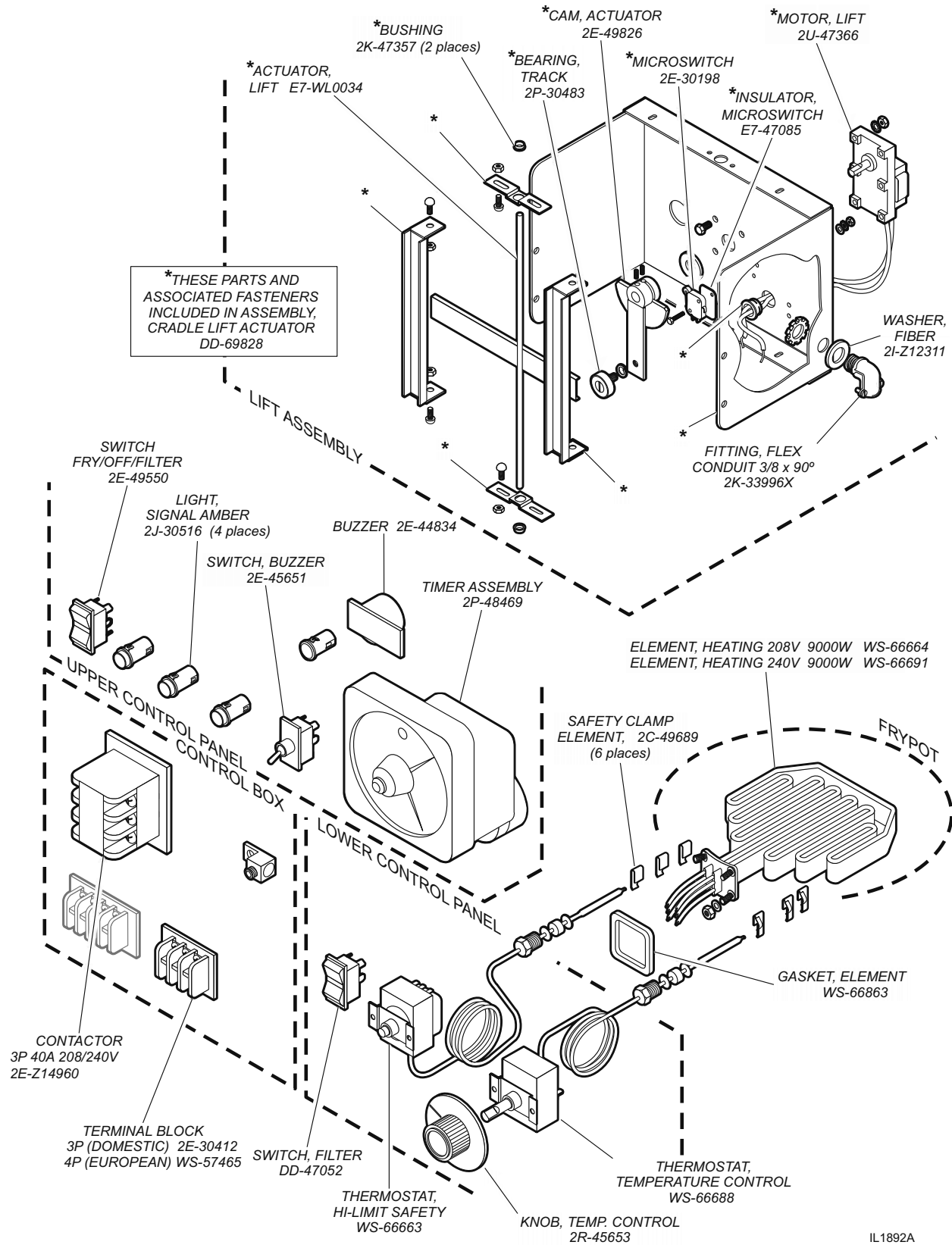

361 2M-301669 Owners Manual WFAE-30F Free-Standing 30# Electric Fryer

IL1892A

EXPLODED VIEW & PARTS LIST

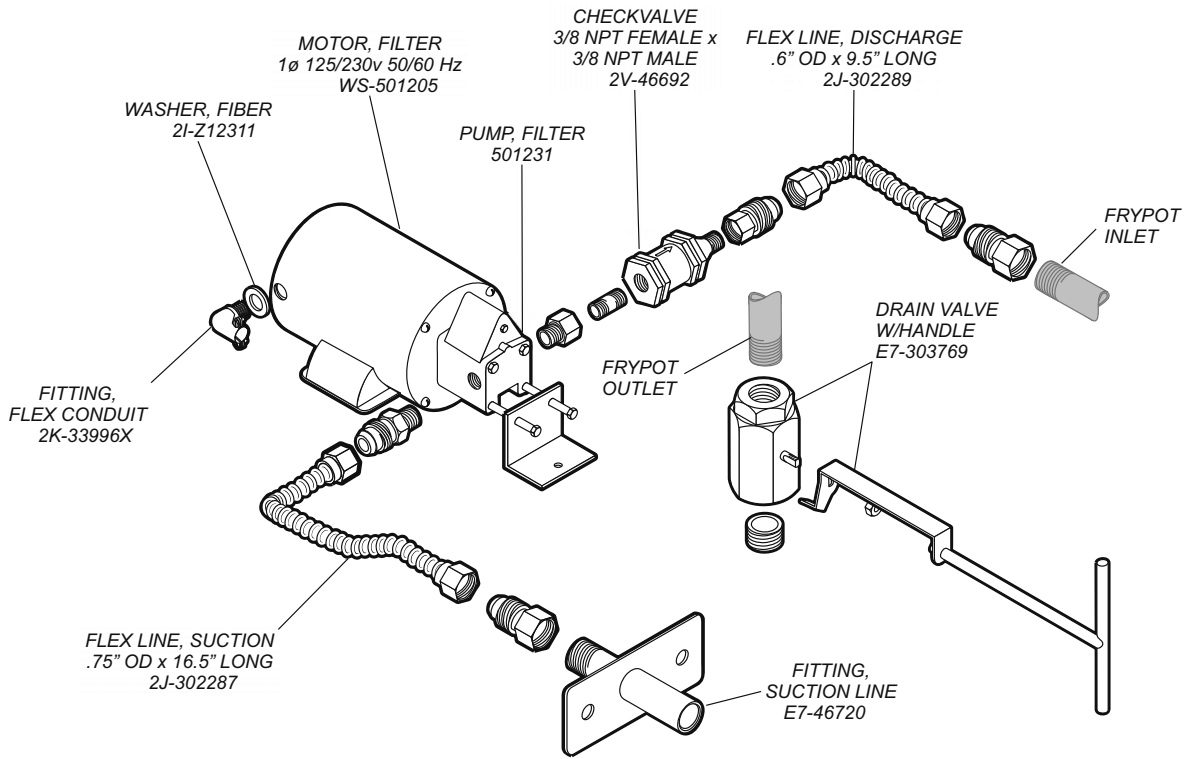

STANDARD FRYER

FRYER W/ OPTIONAL OIL WAND & DRAIN SAFETY SWITCH

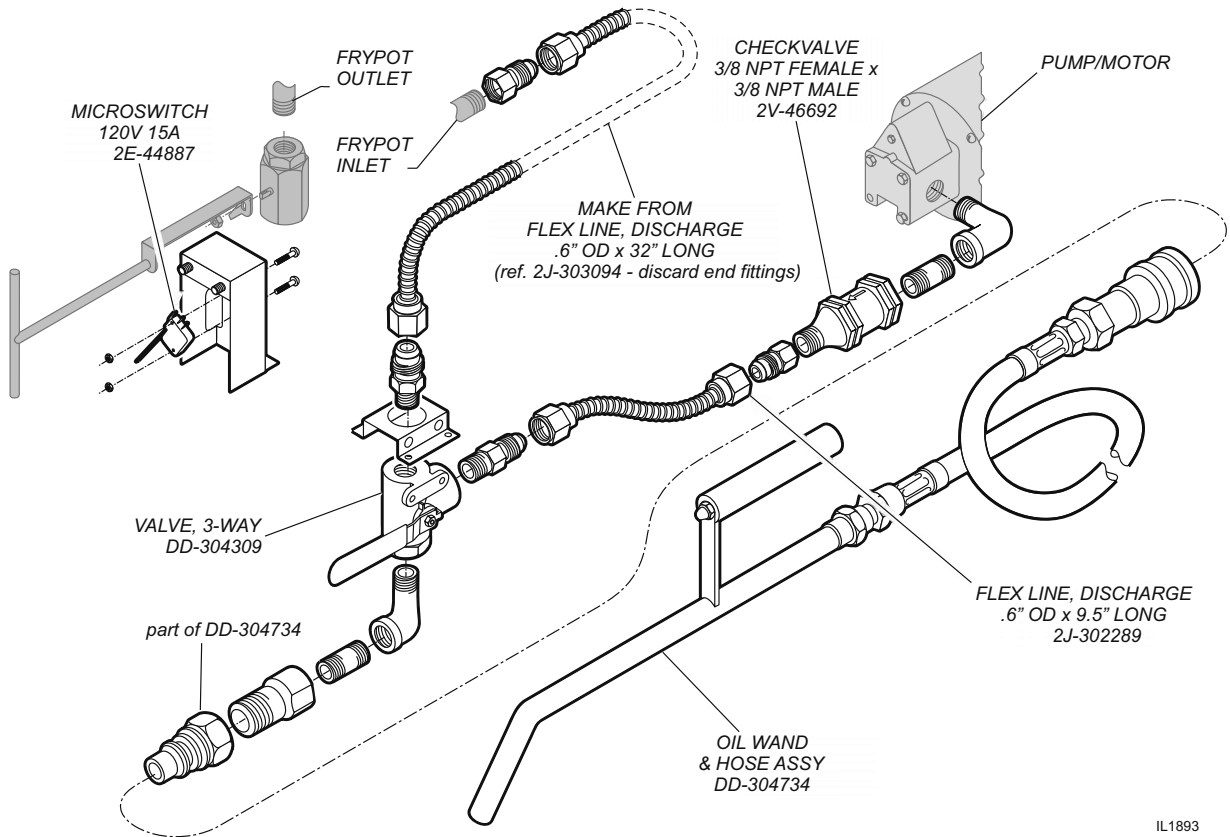

361 2M-301669 Owners Manual WFAE-30F Free-Standing 30# Electric Fryer

IL1893

EXPLODED VIEW & PARTS LIST

WFAE-30F ACCESSORIES & REMOVEABLE COMPONENTS

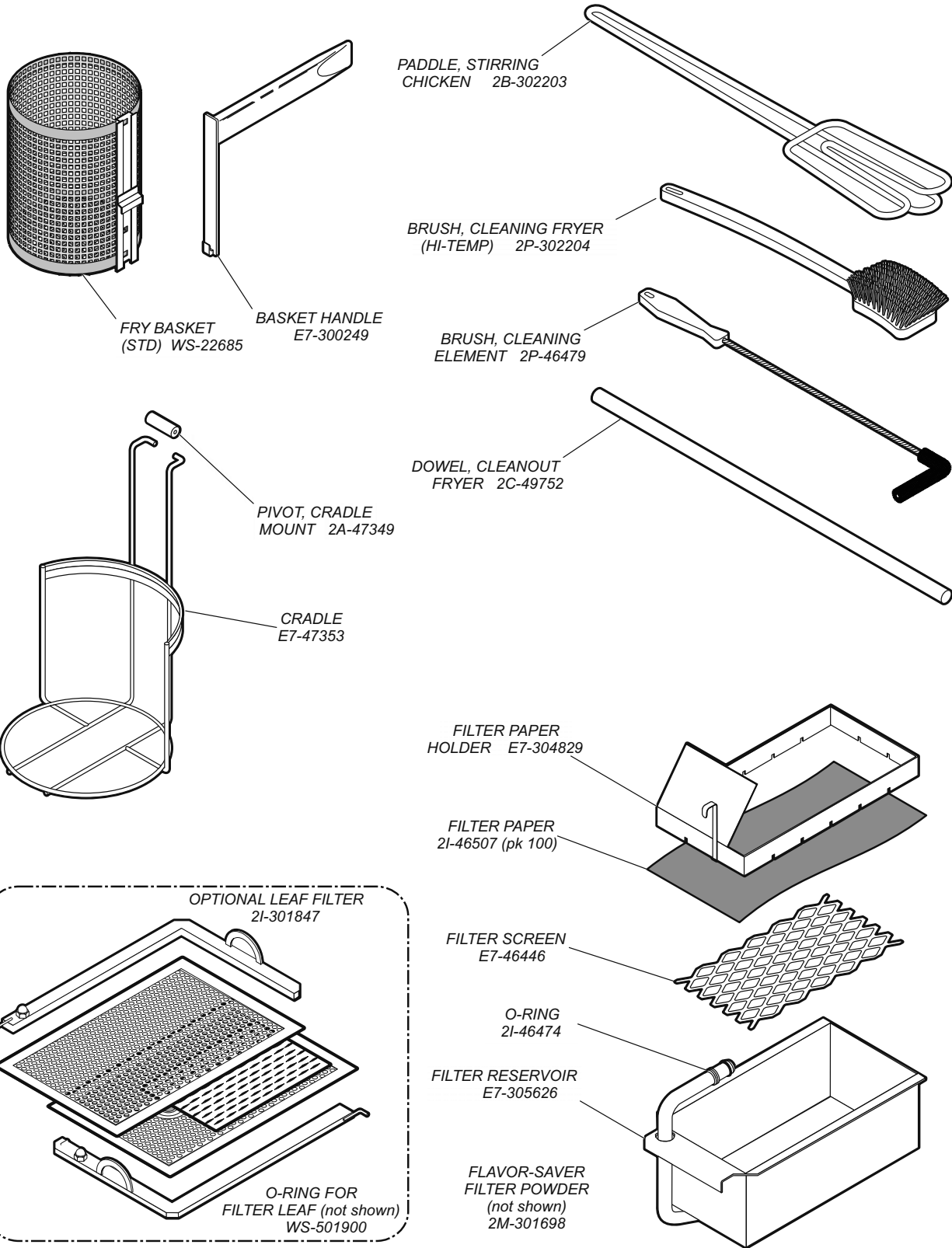

361 2M-301699 Owners Manual WFAE-30F Free-Standing 30# Electric Fryer

WIRING DIAGRAM

361 2M-301669 Owners Manual WFAE-30F Free-Standing 30# Electric Fryer

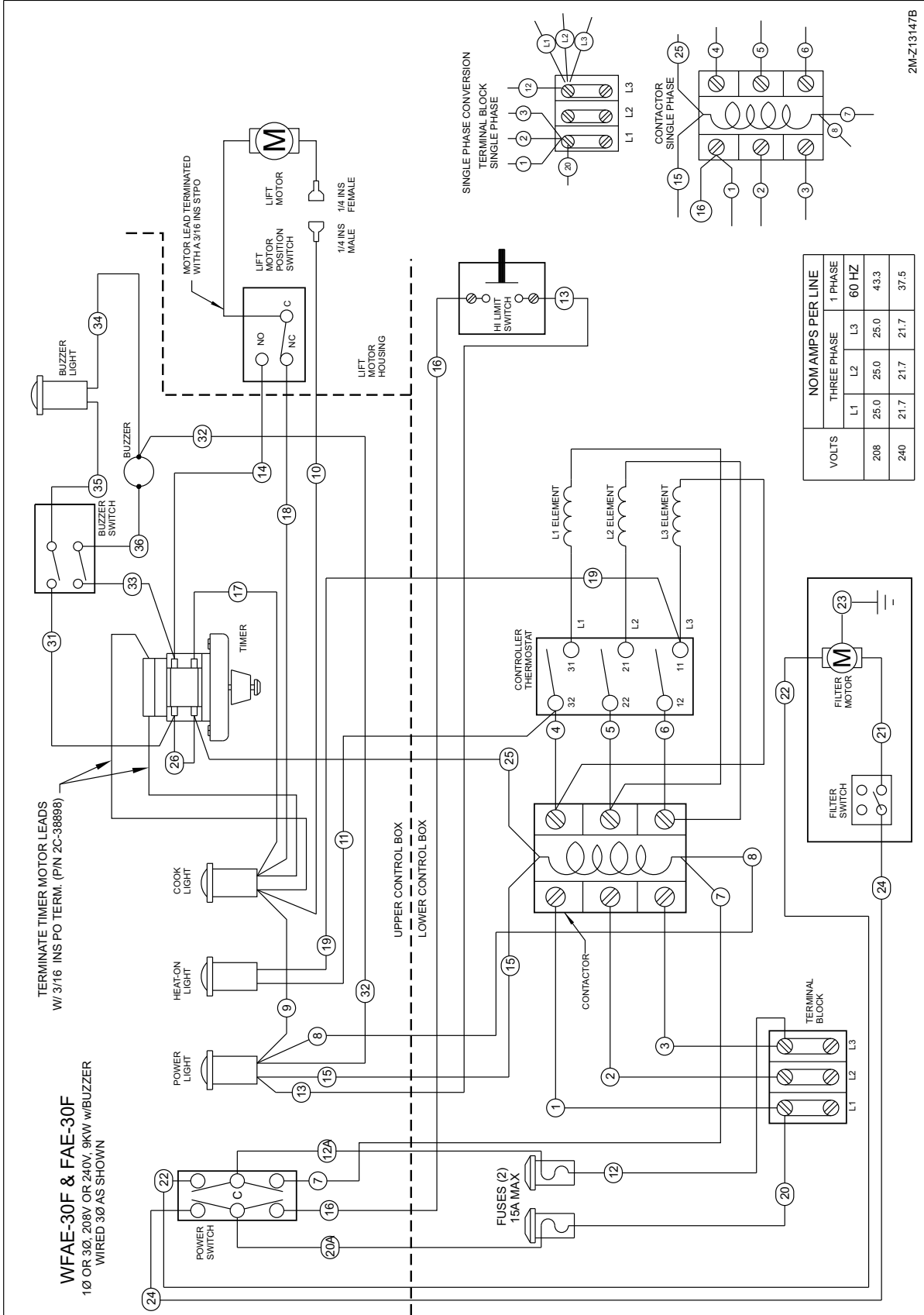

2M-Z13147B

NOTE

NOTE

NOTES

PARTS & SERVICE

DESCRIPTION

PART NO.

BRUSH, CLEANING HEATING ELEMENT	2P-46479
FILTER PAPER, 30-SERIES FRYER (pk100)	2I-46507
FLAVOR-SAVER OIL FILTER POWDER (pk45)	5E-22410
PADDLE, STIRRING CHICKEN	2B-302203
BRUSH, CLEANING FRYPOT	2P-302204
*FILTER WAND ASSY	DD-304734

IMPORTANT: Use only factory authorized service parts and replacement filters.

For factory authorized service, or to order factory authorized replacement parts, contact your Wells authorized service agency, or call:

Wells Manufacturing

265 Hobson Street
Smithville, Tennessee 37166 U.S.A.

Service Dept.

phone: (314) 678-6314

fax: (314) 781-2714

***NOTE:** The filter wand assembly involves a different plumbing arrangement than standard fryer. This option must be ordered at time of initial build and cannot be economically retrofitted to existing fryers.

Service Parts Department can supply you with the name and telephone number of the **WELLS AUTHORIZED SERVICE AGENCY** nearest you.

CUSTOMER SERVICE DATA

please have this information available if calling for service

RESTAURANT _____	LOCATION _____
INSTALLATION DATE _____	TECHNICIAN _____
SERVICE COMPANY _____	
ADDRESS _____	STATE _____ ZIP _____
TELEPHONE NUMBER (____) _____ - _____	
EQUIPMENT MODEL NO. _____	
EQUIPMENT SERIAL NO. _____	
FUEL (check one) <input type="checkbox"/> 208VAC <input type="checkbox"/> 240VAC <input type="checkbox"/> 380-415 3NAC	



Wells Bloomfield proudly supports CFESA
Commercial Food Equipment Service Association

SERVICE TRAINING - QUALITY SERVICE



CUSTOMER SATISFACTION



WELLS MANUFACTURING

265 Hobson Street, Smithville, Tennessee 37166

phone: 314-678-6314

fax: 314-781-2714

www.wells-mfg.com