

EXPLODED VIEW & PARTS LIST

WFAE-30F CABINET COMPONENTS

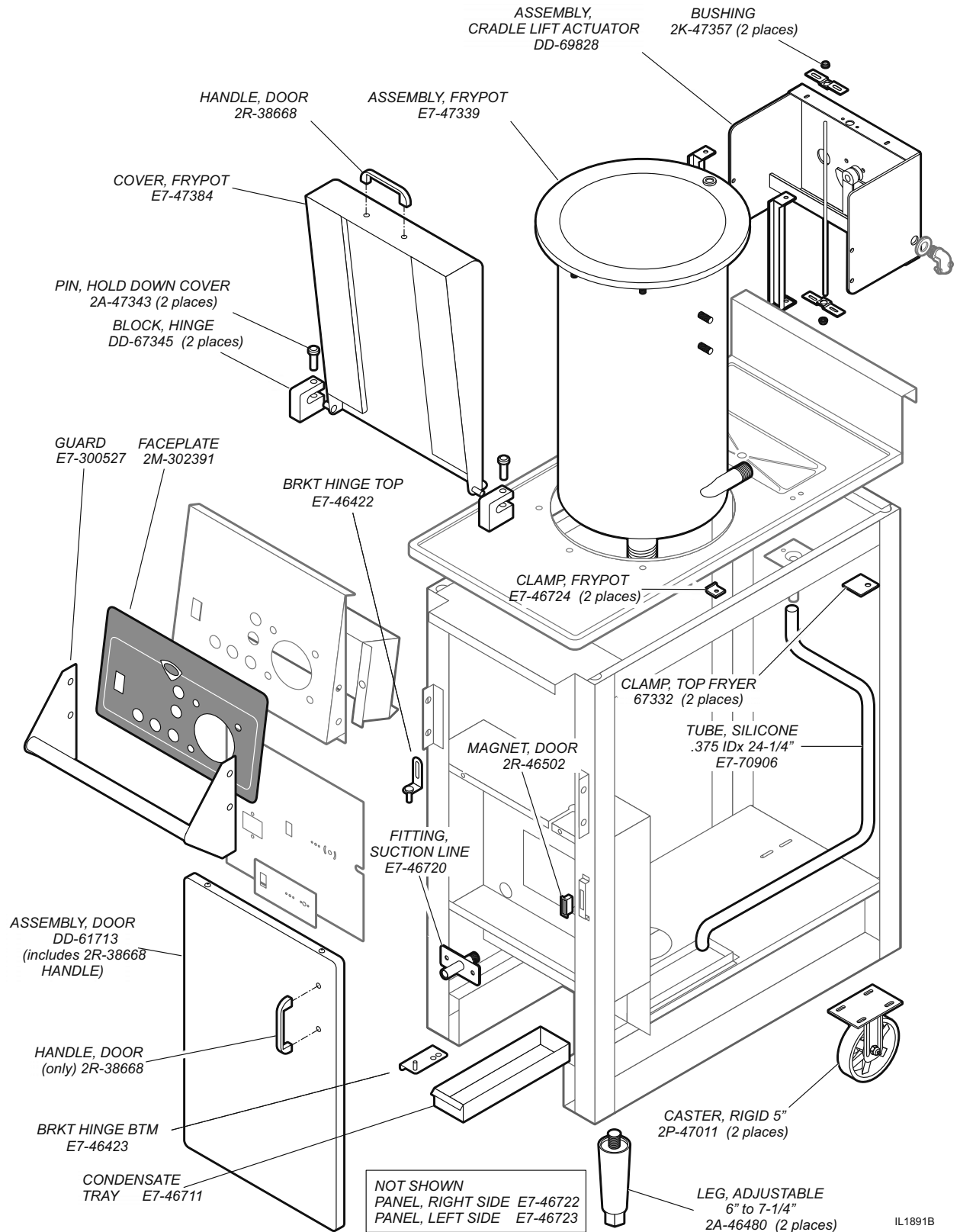

361 2M-301669 Owners Manual WFAE-30F Free-Standing 30# Electric Fryer

IL1891B

EXPLODED VIEW & PARTS LIST

LIFT ACTUATOR & MOTOR ASSEMBLY & HEATING ELEMENTS & ELECTRICAL CONTROL COMPONENTS

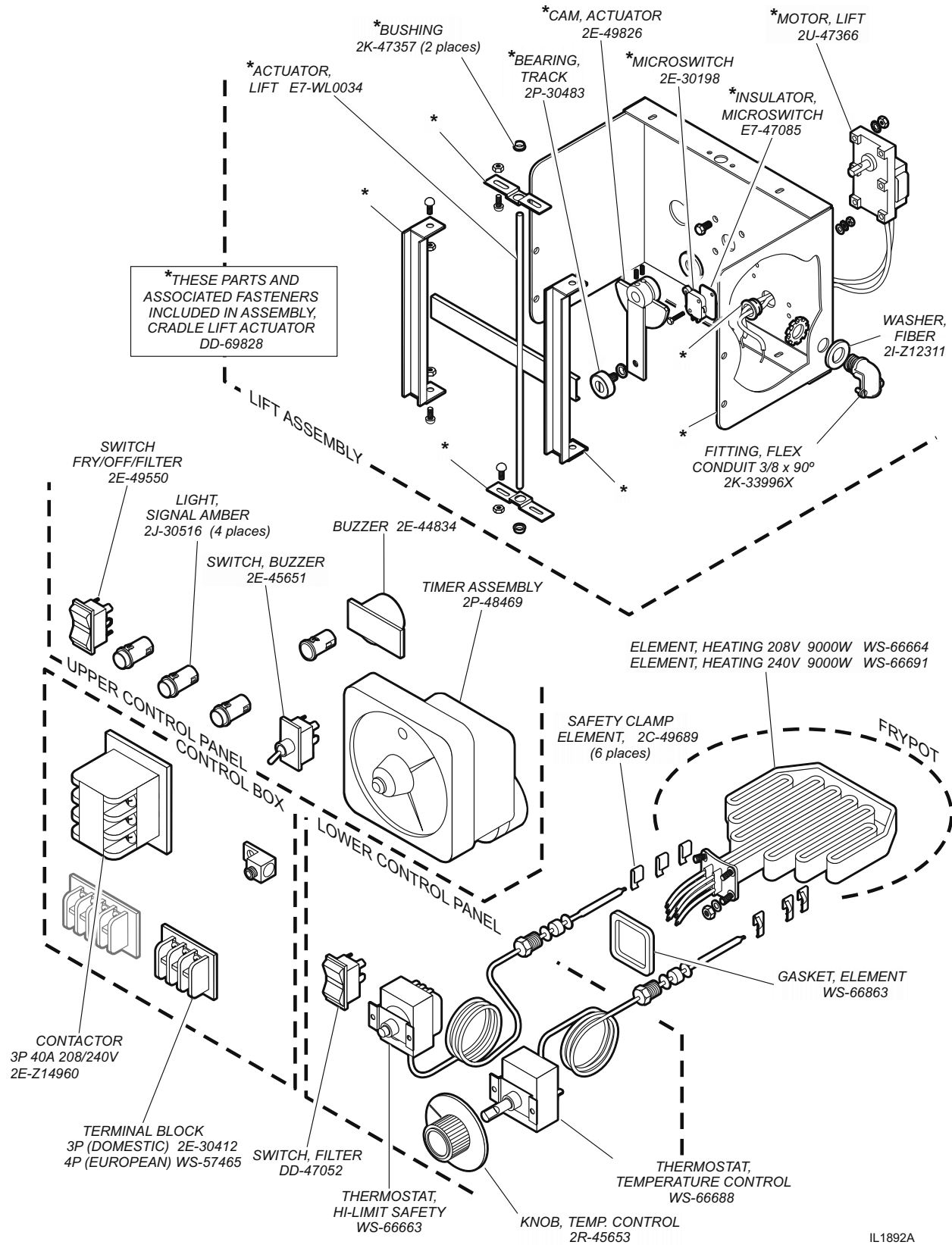

361 2M-301669 Owners Manual WFAE-30F Free-Standing 30# Electric Fryer

IL1892A

EXPLODED VIEW & PARTS LIST

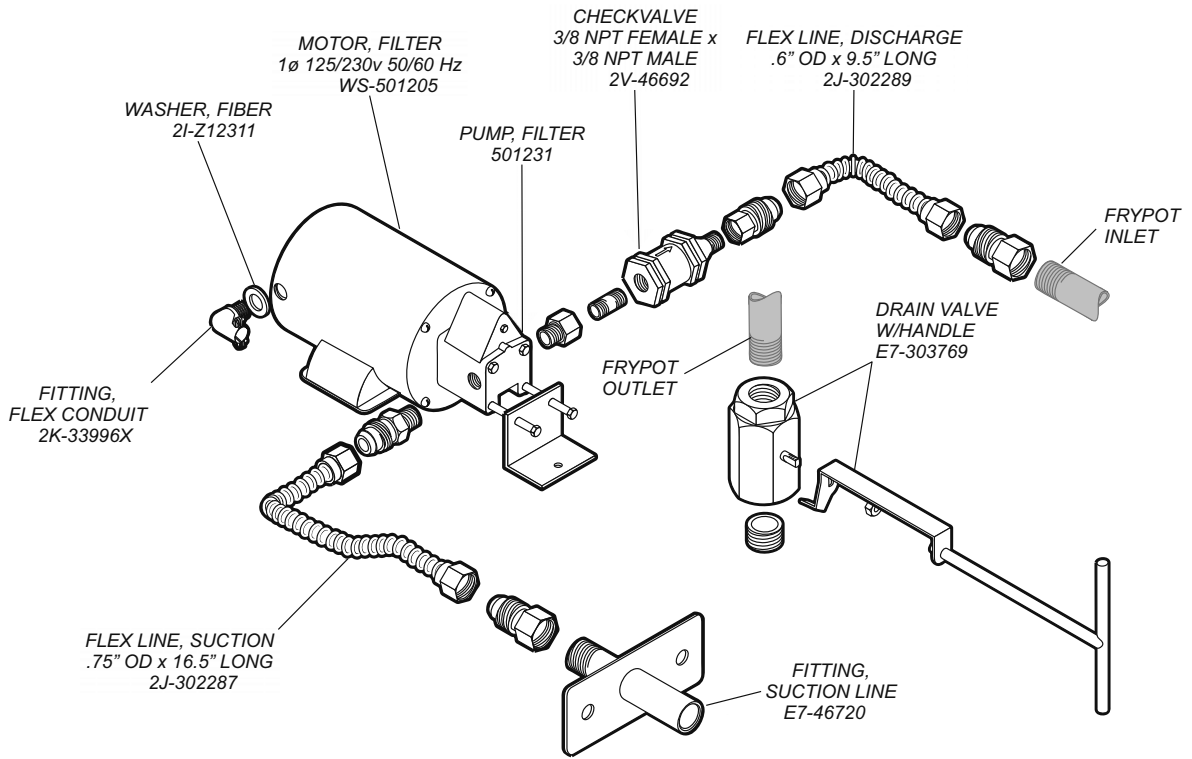

STANDARD FRYER

FRYER W/ OPTIONAL OIL WAND & DRAIN SAFETY SWITCH

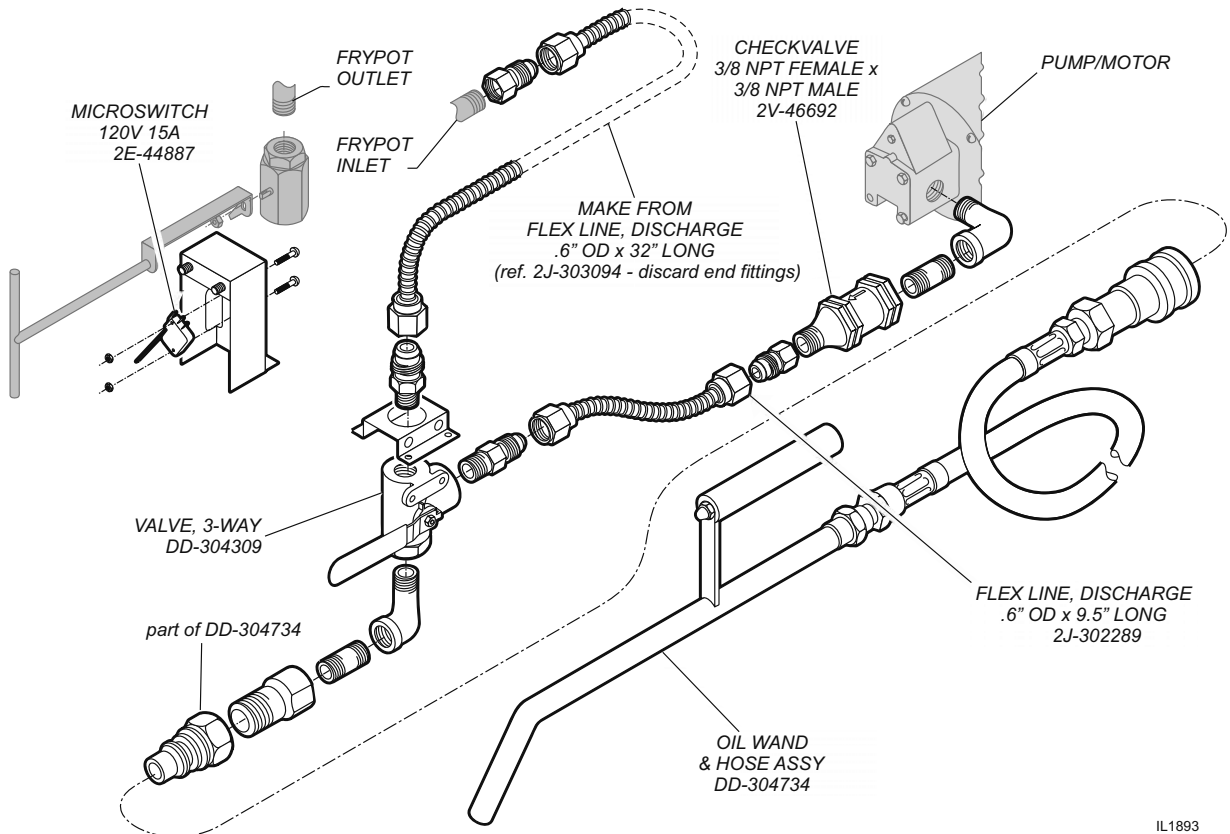

361 2M-301669 Owners Manual WFAE-30F Free-Standing 30# Electric Fryer

IL1893

EXPLODED VIEW & PARTS LIST

WFAE-30F ACCESSORIES & REMOVEABLE COMPONENTS

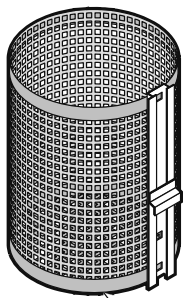

FRY BASKET
(STD) WS-22685

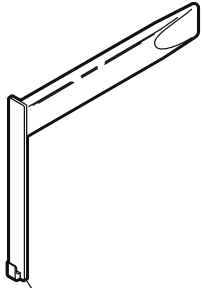

BASKET HANDLE
E7-300249

PADDLE, STIRRING
CHICKEN 2B-302203

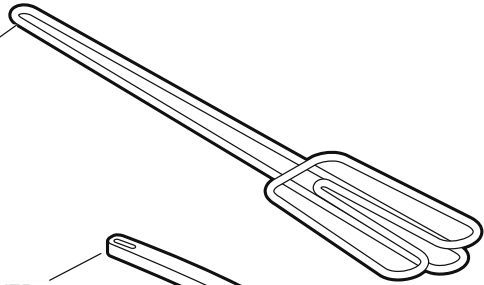

BRUSH, CLEANING FRYER
(HI-TEMP) 2P-302204

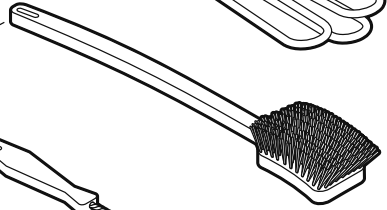

BRUSH, CLEANING
ELEMENT 2P-46479

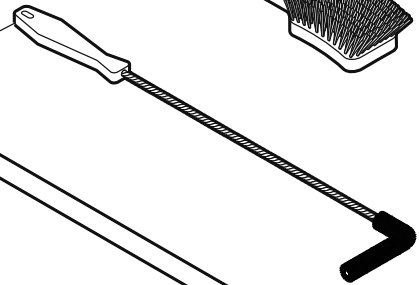

DOWEL, CLEANOUT
FRYER 2C-49752

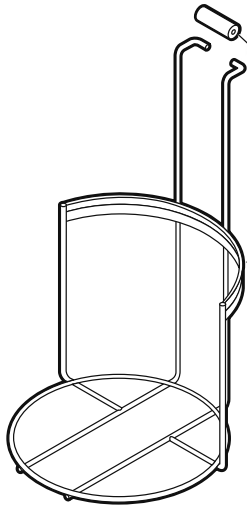
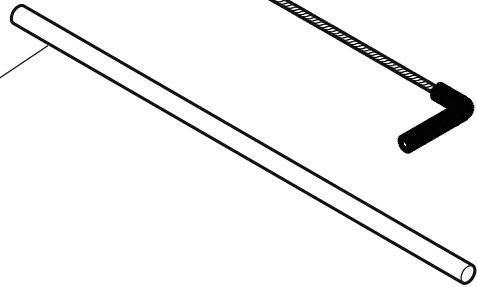

PIVOT, CRADLE
MOUNT 2A-47349

CRADLE
E7-47353

FILTER PAPER
HOLDER E7-304829

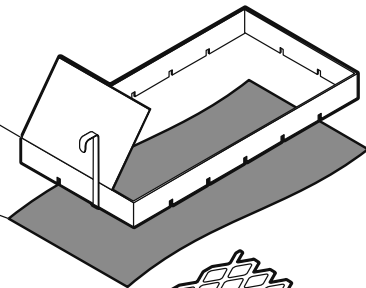

FILTER PAPER
2I-46507 (pk 100)

FILTER SCREEN
E7-46446

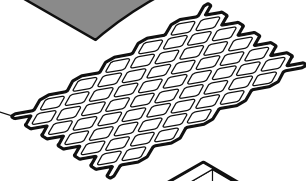

O-RING
2I-46474

FILTER RESERVOIR
E7-305626

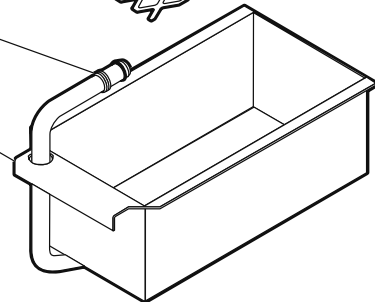

FLAVOR-SAVER
FILTER POWDER
(not shown)
2M-301698

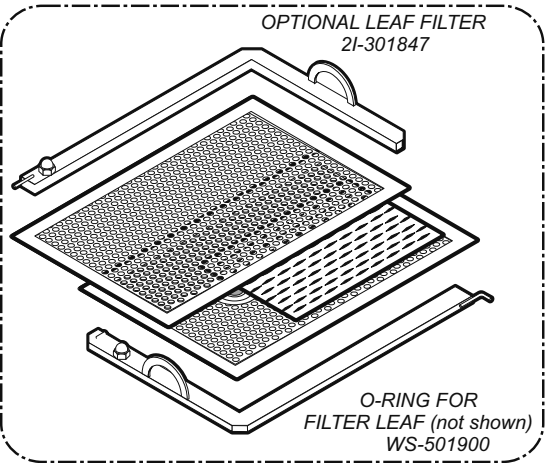

OPTIONAL LEAF FILTER
2I-301847

O-RING FOR
FILTER LEAF (not shown)
WS-501900