



WELLS BLOOMFIELD, LLC
10 Sunnen Dr., St. Louis, MO 63143
telephone: 314-678-6314
fax: 314-781-2714
www.wellsbloomfield.com

363



WFAE55F

OWNERS MANUAL

ELECTRIC
OPEN FRYPOT
55# FRYER
with AUTO-LIFT

MODEL

WFAE55F

WVAE55F

(FRYER SECTION ONLY)

WFAE55FS

WVAE55FS

(FRYER SECTION ONLY)

WITH OR WITHOUT
OPTIONAL FILTER WAND

Includes
INSTALLATION
USE & CARE
EXPLODED VIEW
PARTS LIST
WIRING DIAGRAM

WARNING:

Improper installation, adjustment, alteration, service or maintenance can cause property damage, injury or death. Read the installation and operating instructions thoroughly before installing, using or servicing this equipment.

IMPORTANT: DO NOT DISCARD THIS MANUAL

This manual is considered to be part of the appliance and is to be given to the OWNER or MANAGER of the restaurant, or to the person responsible for TRAINING OPERATORS of this appliance. Additional manuals are available from your WELLS DEALER.

THIS MANUAL MUST BE READ AND UNDERSTOOD BY ALL PERSONS USING OR INSTALLING THIS APPLIANCE. Contact your WELLS DEALER if you have any questions concerning installation, operation or maintenance of this equipment.

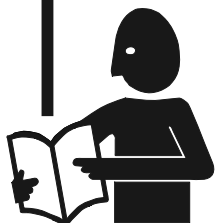

LIMITED WARRANTY STATEMENT

Unless otherwise specified, all commercial cooking equipment manufactured by WELLS BLOOMFIELD, LLC is warranted against defects in materials and workmanship for a period of one year from the date of original installation or 18 months from the date of shipment from our factory, whichever comes first, and is for the benefit of the original purchaser only.

THIS WARRANTY IS THE COMPLETE AND ONLY WARRANTY, EXPRESSED OR IMPLIED IN LAW OR IN FACT, INCLUDING BUT NOT LIMITED TO, WARRANTIES OF MERCHANTABILITY OR FITNESS FOR ANY PARTICULAR PURPOSE, AND/OR FOR DIRECT, INDIRECT OR CONSEQUENTIAL DAMAGES IN CONNECTION WITH WELLS BLOOMFIELD PRODUCTS. This warranty is void if it is determined that, upon inspection by an authorized service agency, the equipment has been modified, misused, misapplied, improperly installed, or damaged in transit or by fire, flood or act of God. It also does not apply if the serial nameplate has been removed, or if service is performed by unauthorized personnel. The prices charged by Wells Bloomfield for its products are

based upon the limitations in this warranty. Seller's obligation under this warranty is limited to the repair of defects without charge by a Wells Bloomfield factory authorized service agency or one of its sub-service agencies. This service will be provided on customer's premises for non-portable models. Portable models (a device with a cord and plug) must be taken or shipped to the closest authorized service agency, transportation charges prepaid, for service. In addition to restrictions contained in this warranty, specific limitations are shown in the Service Policy and Procedure Guide. Wells Bloomfield authorized service agencies are located in principal cities. This warranty is valid in the United States and Canada and void elsewhere. Please consult your classified telephone directory, your foodservice equipment dealer or contact:

Wells Bloomfield, LLC
10 Sunnen Dr., St. Louis MO 63143 USA
phone (314) 678-6314 or fax (314) 781-2714

for information and other details concerning warranty.

SERVICE POLICY AND PROCEDURE GUIDE and ADDITIONAL WARRANTY EXCLUSIONS

1. Resetting of safety thermostats, circuit breakers, over load protectors, and/or fuse replacements are **not** covered by this warranty unless warranted conditions are the cause.
2. All problems due to operation at **voltages or phase other than specified on equipment nameplates** are **not** covered by this warranty. Conversion to correct voltage and/or phase must be the customer's responsibility.
3. All problems due to **electrical connections not made in accordance with electrical code requirements and wiring diagrams** supplied with the equipment are **not** covered by this warranty.
4. Replacement of items **subject to normal wear**, to include such items as knobs, light bulbs; and, normal maintenance functions including adjustments of thermostats, adjustment of micro switches and replacement of fuses and indicating lights are **not** covered by warranty.
5. Damage to electrical cords and/or plug due to exposure to excessive heat are **not** covered by this warranty.
6. Full use, care, and maintenance instructions supplied with each machine. Noted maintenance and preventative maintenance items, such as servicing and cleaning schedules, are customer responsibility. Those miscellaneous adjustments noted are customer responsibility. Proper attention to preventative maintenance and scheduled maintenance procedures will prolong the life of the appliance.
7. Travel mileage is limited to **sixty (60) miles** from an Authorized Service Agency or one of its sub-service agencies.
8. All labor shall be performed during regular working hours. Overtime premium will be charged to the buyer.
9. All genuine Wells replacement parts are warranted for ninety (90) days from date of purchase on non-warranty equipment. This parts warranty is limited only to replacement of the defective part(s). **Any use of non-genuine Wells parts completely voids any warranty.**
10. Installation, labor, and job check-outs are **not** considered warranty and are thus **not** covered by this warranty.
11. Charges incurred by delays, waiting time or operating restrictions that hinder the service technician's ability to perform service are **not** covered by warranty. This includes institutional and correctional facilities.

SHIPPING DAMAGE CLAIM PROCEDURE

NOTE: For your protection, please note that equipment in this shipment was carefully inspected and packaged by skilled personnel before leaving the factory. Upon acceptance of this shipment, the transportation company assumes full responsibility for its safe delivery.

IF SHIPMENT ARRIVES DAMAGED:

1. **VISIBLE LOSS OR DAMAGE:** Be certain that any visible loss or damage is noted on the freight bill or express receipt, and that the note of loss or damage is signed by the delivery person.
2. **FILE CLAIM FOR DAMAGE IMMEDIATELY:** Regardless of the extent of the damage.

3. **CONCEALED LOSS OR DAMAGE:** if damage is unnoticed until the merchandise is unpacked, notify the transportation company or carrier immediately, and file "CONCEALED DAMAGE" claim with them. This should be done within fifteen (15) days from the date the delivery was made to you. Be sure to retain the container for inspection.

Wells Bloomfield cannot assume liability for damage or loss incurred in transit. We will, however, at your request, supply you with the necessary documents to support your claim.

TABLE OF CONTENTS

WARRANTY	xi
SPECIFICATIONS	1
WFAE-55F FEATURES & OPERATING CONTROLS	2
WFAE-55FS FEATURES & OPERATING CONTROLS	4
PRECAUTIONS & GENERAL INFORMATION	6
AGENCY LISTING INFORMATION	7
INSTALLATION	8
PREPARATION PRIOR TO OPERATION	10
OPERATION	
WFAE-55F (MANUAL CONTROLS)	15
WFAE-55FS (SOLID STATE CONTROLS)	16
OPTIONAL FILTER WAND	20
CLEANING	22
MAINTENANCE INSTRUCTIONS	
FILTER SYSTEM	25
DISCARDING USED OIL	28
CRADLE LIFT & ROLLERS	30
TROUBLESHOOTING SUGGESTIONS	31
EXPLODED VIEW & PARTS LIST	34 - 45
WIRING DIAGRAM	46
PARTS & SERVICE	48
CUSTOMER SERVICE DATA	48

INTRODUCTION

Thank You for purchasing this Wells Bloomfield appliance.

Proper installation, professional operation and consistent maintenance of this appliance will ensure that it gives you the very best performance and a long, economical service life.

This manual contains the information needed to properly install this appliance, and to use and care for the appliance in a manner which will ensure its optimum performance.

SPECIFICATIONS

DIMENSIONS	Wide	Deep	High
	15.70"	37.38"	48.94"

CAPACITIES	Cooking Oil (Liquid Shortening Only)	Lbs.	Kg.
		55	25
	Chicken (Fresh)	30	13
	Chicken (Frozen)	25	11

ELECTRICAL SPECIFICATIONS

VOLTAGE REQUIREMENTS	DOMESTIC		EXPORT (EU)
	208 VAC	240VAC	380-415V 3NAC
NOTE: Shipped from factory 3Ø. THIS FRYER IS NOT APPROVED FOR CONVERSION TO 1Ø			
POWER CONSUMPTION	9,000 watts	9,000 watts	9.300 watts
AMPERAGE	47.8 amps per leg (3Ø)	43.0 amps per leg (3Ø)	L1 = 27.0 amps L2 = 26.5 amps L3 = 26.5 amps N = 0.5 amps

FEATURES & OPERATING CONTROLS

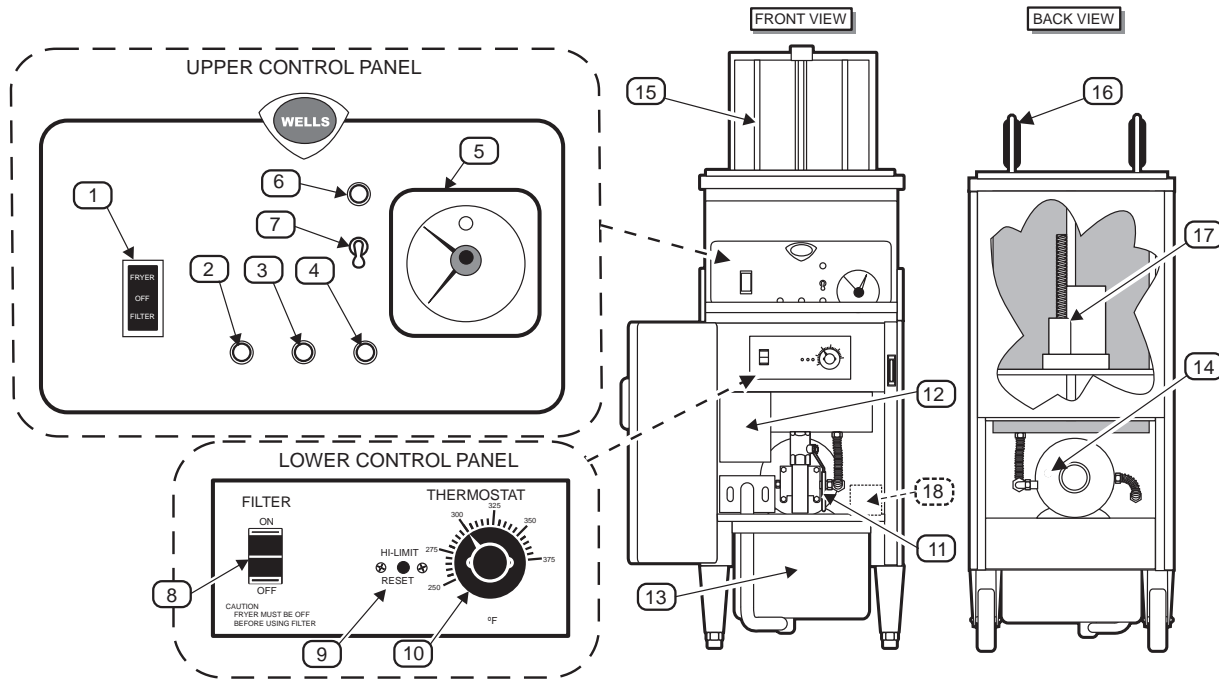

Fig. 1 WFAE-55F Features & Operating Controls

1	POWER SWITCH (FRYER-OFF-FILTER)	FRYER position energizes the FRYER and POWER LIGHT; de-energizes FILTER PUMP. HEATING ELEMENTS energized and regulate to setting on CONTROL THERMOSTAT (8).
		OFF position de-energized FRYER and FILTER PUMP.
		FILTER position de-energizes FRYER; energizes FILTER PUMP SWITCH (6).
2	POWER LIGHT (amber)	Glows to indicate FRYER is energized.
3	HEAT LIGHT (amber)	Glows to indicate HEATING ELEMENT energized; Off when oil temperature reaches setting on CONTROL THERMOSTAT (8).
4	COOK LIGHT (amber)	Glows to indicate COOK LEVER in <i>cook</i> position.
5	TIMER	Controls LIFT CRADLE AND BUZZER. Start TIMER by pressing red button at center of knob. Lift CRADLE will lower. Pointer indicates time remaining. When time reaches "0" BUZZER sounds and LIFT CRADLE raises.
6	BUZZER LIGHT (amber)	When lit, indicates BUZZER SWITCH (item 7) is turned ON and BUZZER CIRCUIT is active
7	BUZZER SWITCH	Activates BUZZER CIRCUIT. When ON will sound BUZZER anytime TIMER is at "0". Turn switch OFF or activate timer to silence buzzer.
8	FILTER PUMP SWITCH (ON-OFF)	ON position energizes FILTER PUMP and causes oil in RESERVOIR (10) to be pumped back into frypot.
		OFF position de-energizes FILTER PUMP.
		NOTE: POWER SWITCH (1) must be in <i>FILTER</i> position for FILTER PUMP to operate.

FEATURES & OPERATING CONTROLS (continued)



WARNING: FIRE HAZARD / HOT OIL

The HI-LIMIT THERMOSTAT is a FIRE PROTECTION DEVICE. If tripping persists, clean debris from the space between the hi-limit bulb and the element to enhance oil flow and facilitate reset. Otherwise, contact your authorized Wells Service Agent for repairs. **DO NOT ATTEMPT TO BYPASS OR HOLD IN THE BUTTON OF THE HI-LIMIT THERMOSTAT. A SERIOUS FIRE MAY RESULT.**

9	HI-LIMIT THERMOSTAT	Provides over-temperature protection by de-energizing HEATING ELEMENTS should oil temperature exceed factory pre-set limits.
10	TEMPERATURE CONTROL THERMOSTAT	Controls oil temperature. Range: 250°F (121°C) 375°F (191°C)
11	DRAIN VALVE LEVER	Opens and closes the DRAIN VALVE: Turn counterclockwise (vertical) to <i>OPEN</i> Turn clockwise (horizontal) to <i>CLOSE</i>
12	POWER OUTLET BOX	Electrical service connection TERMINAL BLOCK located here.
13	OIL FILTER RESERVOIR	Collects oil from FRYPOT for filtering or disposal. Holds filter screen, filter paper & filter paper holder.
14	FILTER PUMP MOTOR RESET BUTTON (located at rear of motor)	FILTER PUMP MOTOR is equipped with an overheating protection device. RESET must be performed manually. Allow motor to cool for approx. 30 min, then firmly press the red button.
15	LIFT CRADLE	Lowers fry basket into frypot during cook cycle. Automatically raises from frypot at end of cook cycle
16	FRY BASKET	Holds product to be cooked.
17	LIFT MOTOR	Raises/lowers LIFT CRADLE. Accessible for lubrication thru access plate in rear panel.
18	DRIP PAN	Collects liquids that accumulate on top of fryer section of Ventilator Hood models (WVAE-...).

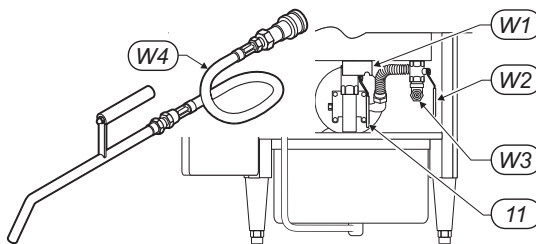

For units equipped with OPTIONAL FILTER WAND

W1	HEATER INTERLOCK SWITCH	Disables heating element any time drain valve is not closed.
W2	3-WAY VALVE HANDLE	HORIZONTAL directs output of filter pump to filter wand. VERTICAL directs output of filter pump to frypot.
W3	QUICK DISCONNECT MALE FITTING	Filter wand connects to this fitting.
W4	FILTER WAND	Used to wash down sides of frypot, or to direct oil to disposal container.

FEATURES & OPERATING CONTROLS

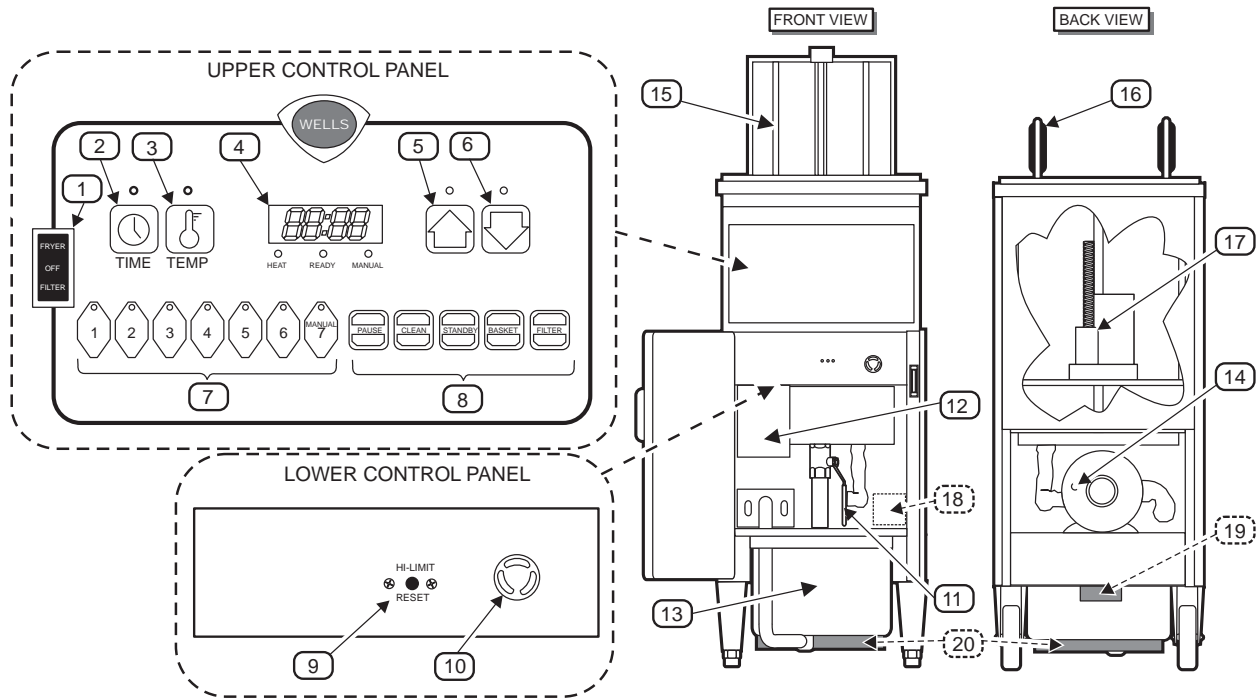

Fig. 1 WFAE-55FS Features & Operating Controls

1	POWER SWITCH (FRYER-OFF-FILTER)	FRYER position energizes the FRYER and POWER LIGHT; de-energizes FILTER PUMP. HEATING ELEMENTS energized and regulate to setting on CONTROL THERMOSTAT (8).
		OFF position de-energized FRYER and FILTER PUMP.
		FILTER position de-energizes FRYER; energizes FILTER PUMP SWITCH (6).
2	TIME KEY	Used to check and set menu times
3	TEMP KEY	Used to check and set cooking temperature
4	DIGITAL READOUT	LED display of various data and functions
5	UP ARROW KEY	Used to raise FRY BASKET and to increase program settings
6	DOWN ARROW KEY	Used to lower FRY BASKET and to decrease program settings
7	MENU KEYS	Used to start a menu time/temp cook cycle Keys 1 thru 6 are programmable for time and temperature Key 7 is available for individually set time/temp cook cycles
8	FUNCTION KEYS	Used to perform the functions of: PAUSE CLEAN STANDBY BASKET (raise/lower when used with up arrow & down arrow) FILTER (acknowledgement warning signal)

FEATURES & OPERATING CONTROLS (continued)



WARNING: FIRE HAZARD / HOT OIL

The HI-LIMIT THERMOSTAT is a FIRE PROTECTION DEVICE. If tripping persists, clean debris from the space between the hi-limit bulb and the element to enhance oil flow and facilitate reset. Otherwise, contact your authorized Wells Service Agent for repairs. **DO NOT ATTEMPT TO BYPASS OR HOLD IN THE BUTTON OF THE HI-LIMIT THERMOSTAT. A SERIOUS FIRE MAY RESULT.**

9	HI-LIMIT THERMOSTAT	Provides over-temperature protection by de-energizing HEATING ELEMENTS should oil temperature exceed factory pre-set limits.
10	SONALERT	Audible alarm to signal end of cook cycle and other programmed functions
11	DRAIN VALVE LEVER	Opens and closes the DRAIN VALVE: Turn counterclockwise (vertical) to <i>OPEN</i> Turn clockwise (horizontal) to <i>CLOSE</i>
12	POWER OUTLET BOX	Electrical service connection TERMINAL BLOCK located here.
13	OIL FILTER RESERVOIR	Collects oil from FRYPOT for filtering or disposal. Holds filter screen, filter paper & filter paper holder.
14	FILTER PUMP MOTOR RESET BUTTON (located at rear of motor)	FILTER PUMP MOTOR is equipped with an overheating protection device. RESET must be performed manually. Allow motor to cool for approx. 30 min, then firmly press the red button.
15	LIFT CRADLE	Lowers fry basket into frypot during cook cycle. Automatically raises from frypot at end of cook cycle
16	FRY BASKET	Holds product to be cooked.
17	LIFT MOTOR	Raises/lowers LIFT CRADLE. Accessible for lubrication thru access plate in rear panel.
18	DRIP PAN	Collects liquids that accumulate on top of fryer section of Ventilator Hood models (WVAE-...).
FOR UNITS WITH SOLID SHORTENING MELT OPTION		
19	CONTACT BLOCK	Low voltage electric connection for FILTER RESERVOIR HEATER
20	FILTER RESERVOIR HEATER	Keeps shortening in FILTER RESERVOIR in a liquid state. IMPORTANT: Filter pump will not pump shortening unless it is in the liquid state. FILTER PUMP, OIL SUCTION LINE and OIL RETURN LINE are heated at all times fryer is connected to electric power so that shortening will not solidify. Heater circuit is low voltage.

PRECAUTIONS AND GENERAL INFORMATION

DANGER

DANGER: BURN HAZARD

Cooking oil in this appliance operates at very high temperatures. Contact with hot oil can cause severe injury or death. Wear appropriate heat-protective clothing when operating or servicing this appliance.



WARNING: BURN HAZARD

DO NOT allow water or ice to contact hot oil. DO NOT attempt to cool the oil with water or ice. The water will boil violently, causing hot oil to foam and splatter. Contact with splattering or foaming hot oil will cause severe burns.



WARNING: SLIP AND FALL HAZARD

Spilled cooking oil is very slippery and can cause falls. Clean up oil spills promptly.



CAUTION: BURN HAZARD

Exposed surfaces can be hot to the touch and may cause burns.



CAUTION: HEALTH HAZARD

Old cooking oil can be a breeding ground for bacteria. Clean and sanitize exterior surfaces of fryer regularly.

This appliance is intended for use in commercial establishments only.

This appliance is intended to prepare food for human consumption. No other use is recommended or authorized by the manufacturer or its agents.

DO NOT open any panel that requires the use of tools for access. Live electric circuits may be exposed by opening such panels. Opening access panels must be performed by an Authorized Service Agent only.

This appliance is equipped with an oil filtration system designed to filter hot liquid shortening only. Water, cleaning agents and/or other liquids will contaminate the oil and may damage the filter pump.

Operators of this appliance must be familiar with the appliance use, limitations and associated restrictions. Operating instructions must be read and understood by all persons using or installing this appliance.

Cleanliness of this appliance is essential to good sanitation. Read and follow all included cleaning instructions and schedules to ensure the safety of the food product.

DO NOT submerge any part of this appliance in water unless specifically instructed to do so. This appliance is not jet stream approved. DO NOT direct water jet or steam jet at this appliance, nor at any control. DO NOT splash or pour water on, in or over any controls. DO NOT wash area around this appliance with water jet. Any part which has become wet must be thoroughly dried before use.

Cooking oil will be very hot when in use. Contact will cause severe injury, and can cause blindness or death. Wear appropriate heat-protective clothing when operating or servicing this appliance.

This appliance must be operated with the supplied legs and casters properly installed

The technical content of this manual, including any parts breakdown illustrations and/or adjustment procedures, is intended for use by qualified technical personnel only.

Any procedure which requires the use of tools must be performed by a qualified technician.

This manual is considered to be a permanent part of the appliance. This manual and all supplied instructions, diagrams, schematics, parts breakdown illustrations, notices and labels must remain with the appliance if it is sold or moved to another location.

AGENCY LISTING INFORMATION

This appliance conforms to NSF Standard 4 for sanitation only if installed in accordance with the supplied *Installation Instructions* and maintained according to the instructions in this manual.

Domestic fryers are  and  listed under UL File E6070 for 208V and 240V.

Export (European) fryers comply with  standards for 380-415V 3NAC.



STD 4



E6070



E6070



INSTALLATION

NOTE: DO NOT discard the carton or other packing materials until you have inspected the appliance for hidden damage and tested it for proper operation. Refer to *SHIPPING DAMAGE CLAIM PROCEDURE* on the inside front cover of this manual.



WARNING: FIRE HAZARD

Do not store gasoline or any other flammable or combustible material near this appliance. The area where the fryer is installed must be kept clear of combustibles and flammables. This includes mops, rags, grease, wrapping paper and electric cords.

Installation and startup must be performed by a Wells Manufacturing Authorized Service Agency.

IMPORTANT:

Certain jurisdictions require fryers to be restrained with a TETHER or other approved restraint device. It is the responsibility of the installer to check with the AUTHORITY HAVING JURISDICTION in order to ascertain the applicability of this requirement to THIS SPECIFIC INSTALLATION.

Installer must complete the WARRANTY REGISTRATION and FRYER CHECKOUT form, and record the details of the particular installation on the CUSTOMER SERVICE DATA form in this manual.

UNPACKING & INSPECTION

Carefully remove the appliance from the carton. Remove all protective plastic film, packing materials and accessories from the appliance before connecting performing any installation procedure.

Carefully read all instructions in this manual and the *Installation Instruction Sheet* packed with the appliance before starting any installation.

Read and understand all labels and diagrams attached to the appliance.

Carefully account for all components and accessories before discarding packing materials. Store all accessories in a convenient place for later use.

COMPONENTS

- 1 ea. FILTER RESERVOIR
- 1 ea. FILTER LEAF
- 4 ea. OIL FILTER SUCTION TUBE O-RINGS
- 1 ea. LIFT CRADLE
- 1 ea. FRY BASKET
- 1 ea. FRYPOT COVER

ACCESSORIES

- 1 ea. LITERATURE PACKAGE
- 1 pk. FILTER POWDER
- 2 ea. HIGH TEMPERATURE BRUSHES
- 1 ea. CLEANOUT DOWEL (wood rod)
- 1 ea. 1-1/4 NPT STREET ELBOW
- 1 ea. 1-1/4 NPT x 12" DRAIN PIPE

SETUP

It is the responsibility of the installer to verify that this fryer installation is in compliance with local code authorities and with the specifications listed in this manual.

Certain local or state codes require fryers to be restrained with a tether or other approved restraint device. It is the responsibility of the installer to check with the authority having jurisdiction, in order to ascertain the applicability of this requirement to this specific fryer installation.

Setup the fryer only on a firm, level, non-combustible surface. Verify local codes for requirements. Concrete, tile, terrazzo or metal surfaces are recommended. Metal or tile over combustible material may not meet code for non-combustible surfaces.

Verify that the unit sits firmly ON BOTH CASTERS AND BOTH LEGS. With the adjustable legs, adjust as required to level the appliance. Both legs and both casters must be adjusted to firmly contact the floor in order to prevent tipping.

Refer to the *Installation Instruction Sheet* for required clearances. Maintain required clearances between the appliance and adjacent combustible surfaces.

INSTALLATION (continued)

ELECTRICAL INSTALLATION

Refer to the nameplate on the front of the fryer and to the specifications listed on page 1 of this manual. Verify that electric service voltage, phase and amperage capacity meet or exceed these specifications.

Field wiring must be no less than 4 ga. solid copper wire, rated for at least 90°C.

Fryers are shipped from the factory wired for 3Ø. Fryer is not approved for conversion to single phase.

IMPORTANT:

Field wiring must be routed and secured away from the FRYPOT, TUBING and FILTER PUMP MOTOR. Field wiring must be configured to allow access to the rear of fryer for cleaning and access to the filter pump motor RESET BUTTON.

IMPORTANT:

Electric installation of this appliance must be performed by a licensed electrician. Installation must conform to the requirements of local codes and ordinances, and to the requirements of the National Electrical Code.

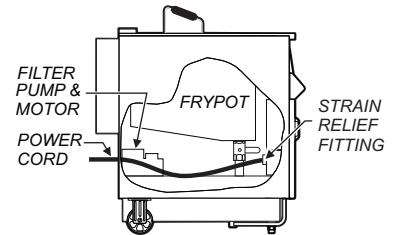

Fig. 2 Field Wiring

IMPORTANT:

This appliance is rated for 3Ø electric service only, and is not UL approved for single phase operation. DO NOT convert this appliance to single phase. Doing so will void the warranty and invalidate the UL listing.

PREPARATION PRIOR TO OPERATION

WVAE-55F PRE-CLEANING PROCEDURE



WARNING: BURN HAZARD

TURN THERMOSTAT TO LOWEST TEMPERATURE SETTING
(FULLY COUNTERCLOCKWISE)
USE ONLY LOW-FOAMING COMMERCIAL FRYER CLEANSER.
CAREFULLY FOLLOW CLEANSER INSTRUCTIONS AND WARNINGS.
DO NOT LEAVE FRYER UNATTENDED
WHILE BOILING OUT FRYPOT.
WHEN WATER BEGINS FOAMING,
BE PREPARED TO TURN POWER SWITCH OFF.
Boiling water and splatter can result in moderate to serious injury.

Prior to leaving the factory, each fryer is tested for proper operation. Oil residue must be cleaned from the frypot before filling it with fresh oil.

IMPORTANT:
Use a **LOW-FOAMING COMMERCIAL** fryer cleanser only.

Press **POWER SWITCH OFF**.

Close **DRAIN VALVE** (lever horizontal).
Fill **FRYPOT** with 4 gallons of cold water.

Press **POWER SWITCH** to **FRYER**.

When water comes to a full boil, press **POWER SWITCH OFF**.
When boiling ceases, slowly add and stir in the **LOW FOAMING COMMERCIAL FRYER CLEANSER**. Using the **HIGH TEMPERATURE BRUSH** supplied with the fryer, stir until the cleanser is completely dissolved.

Press **POWER SWITCH** to **FRYER**. When the water begins to boil, press **POWER SWITCH OFF**. When the boiling subsides, again press **POWER SWITCH** to **FRYER**. Repeat this procedure continuously for five (5) minutes.

Press **POWER SWITCH OFF**. Allow the solution to cool to 120°F or less.

Place a suitable **METAL** container under the **DRAIN VALVE**. Open **DRAIN VALVE** (lever vertical) to drain the cleaning solution.

NOTE: Drain no more than 4" at a time into the container to prevent splashing and spilling. Dispose of used solution as required by local ordinances.

Rinse frypot with clean water. Dry with a soft clean cloth.

PREPARATION PRIOR TO OPERATION (continued)

WVAE-55FS PRE-CLEANING PROCEDURE



WARNING: BURN HAZARD

USE THE **CLEAN** BUTTON ONLY

USE ONLY LOW-FOAMING COMMERCIAL FRYER CLEANSER.
CAREFULLY FOLLOW CLEANSER
CLEANING INSTRUCTIONS AND WARNINGS

DO NOT LEAVE FRYER UNATTENDED WHILE BOILING OUT FRYPOT.

BE PREPARED TO TURN POWER SWITCH OFF SHOULD WATER BEGIN FOAMING
Boiling water can splatter and may cause serious injury

Press POWER SWITCH OFF.

Close DRAIN VALVE (lever horizontal).
Fill FRYPOT with 4 gallons of cold water.

Press POWER SWITCH to FRYER.

Wait 10 seconds, then press and hold CLEAN button for six seconds.
A beep will sound and readout will display "BOIL".

Slowly add and stir in the *LOW FOAMING COMMERCIAL FRYER CLEANSER*. Using the HIGH TEMPERATURE BRUSH supplied with the fryer, stir until the cleanser is completely dissolved.

Time displayed is elapsed time. When display reads "1:30", press POWER SWITCH OFF. Allow the solution to cool to 120°F or less.

Place a suitable METAL container under the DRAIN VALVE. Open DRAIN VALVE (lever vertical) to drain the cleaning solution.

NOTE: Drain no more than 4" at a time into the container to prevent splashing and spilling. Dispose of used solution as required by local ordinances.

Rinse frypot with clean water. Dry with a soft clean cloth.

IMPORTANT:

Use a LOW-FOAMING
COMMERCIAL fryer cleanser
only.



PREPARATION PRIOR TO OPERATION (continued)

IMPORTANT:

Serious damage to the frypot will result if the rollers are missing or do not rotate freely.

Examine the CRADLE ROLLERS. Adjust or tighten as required. Lubricate the rollers with vegetable oil.

DO NOT operate the fryer unless CRADLE ROLLERS are in place and rotating freely.

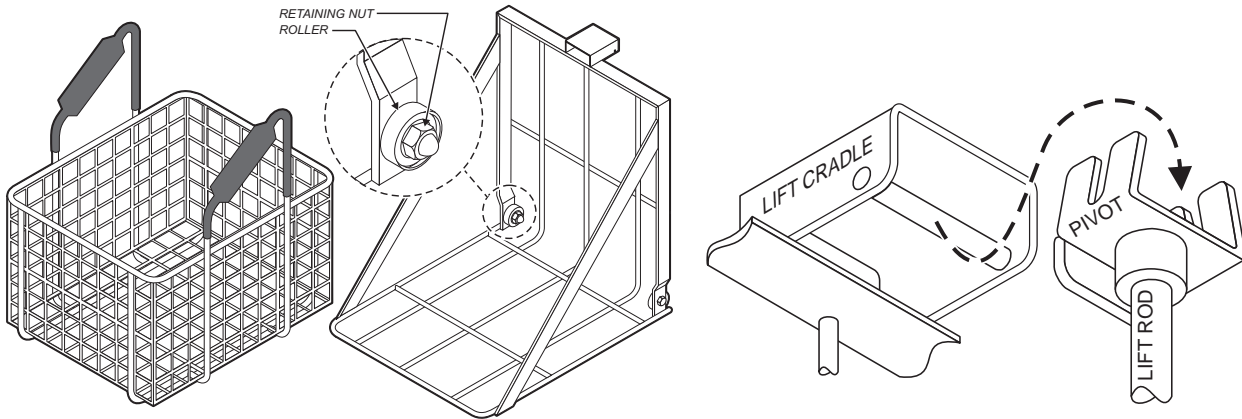

Install LIFT CRADLE onto CRADLE PIVOT. Set FRY BASKET on LIFT CRADLE.

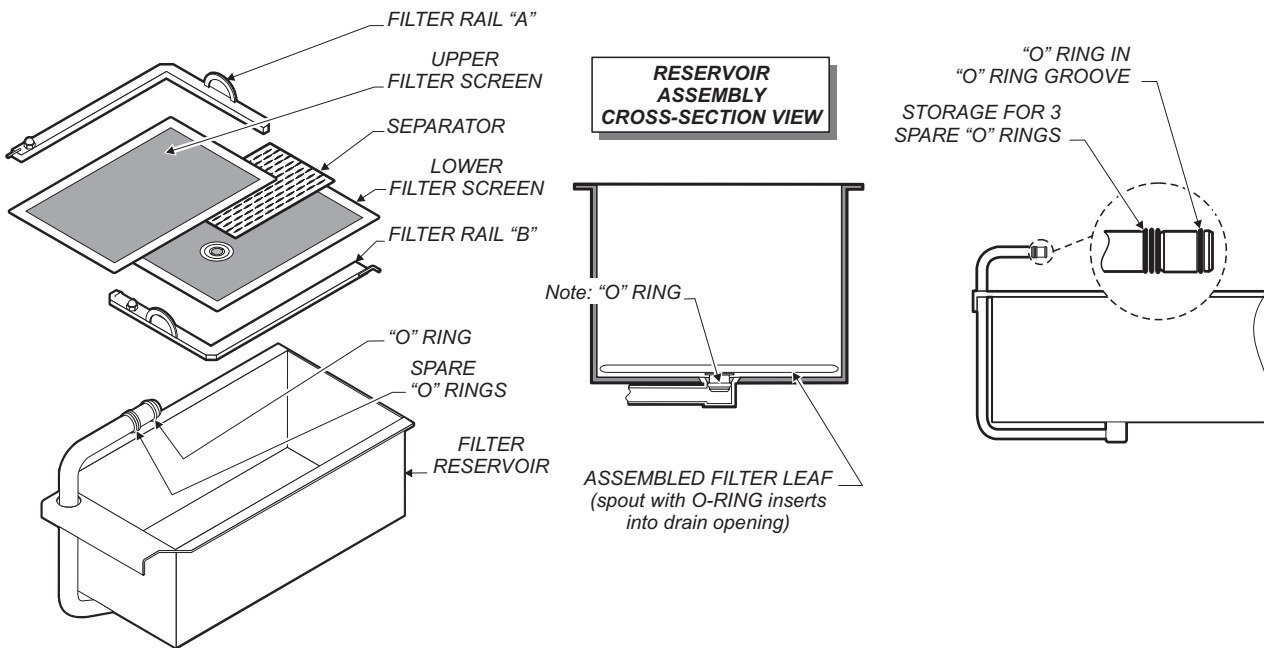

Install FILTER LEAF into FILTER RESERVOIR.

SUCTION TUBE O-RINGS are shipped from the factory installed on SUCTION TUBE; Examine to verify one O-RING is in the groove closest to the end of the tube.

Install assembled FILTER RESERVOIR into fryer. O-RING for the filter reservoir suction tube, and up to three spare O-RINGS, are stored as shown above.

PREPARATION PRIOR TO OPERATION (continued)



WARNING: SLIP/FALL HAZARD

DO NOT OPERATE UNLESS DRIP PAN IS INSTALLED.

Oil will drip on the floor and slips/falls will result. Death or serious injury may result from slipping and falling in spilled oil.

FOR FRYERS WITH VENT HOOD (WVAE-55.....)

For Ventilator Hood models (i.e. WVAE-55 FS), install DRIP PAN (item 18) into mounting bracket behind fryer door at lower right front of fryer.

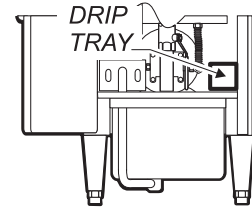

WARNING: SLIP/FALL HAZARD

CLOSE DRAIN VALVE BEFORE FILLING WITH OIL.

Unless drain valve is closed, oil poured into kettle will drain into reservoir or onto the floor. Oil spill may occur. Death or serious injury may result from slipping and falling in spilled oil.

Close DRAIN VALVE LEVER (item 11) by turning the lever up to the horizontal (*CLOSED*) position.

IMPORTANT: Remember to fill the fryer to the *COLD OIL LINE* with fresh shortening prior to turning the POWER SWITCH to the FRYER position. Energizing the fryer without oil covering the elements will cause serious damage. Damage caused by operating the fryer without oil covering the elements is **not covered by warranty**. Fill FRYPOT to the *COLD OIL LINE* in the FRYPOT with room

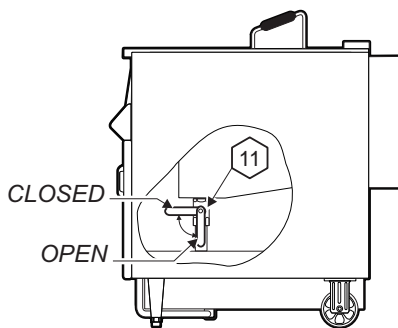

FILL TO THIS LINE WITH ROOM TEMPERATURE LIQUID SHORTENING



IMPORTANT:

Unless equipped with the factory-installed **SOLID SHORTENING MELT OPTION**, this fryer is designed for **LIQUID SHORTENING ONLY**. **DO NOT USE SOLID SHORTENING UNLESS THE FRYER IS EQUIPPED WITH THE SOLID SHORTENING MELT OPTION. DO NOT USE LARD.**

Solid shortening will solidify in the **FILTER RESERVOIR** and **FILTER PUMP**. This condition will render the filter system inoperable. Do not attempt to pump shortening unless it is liquid shortening or shortening melted to the liquid state. Damage caused to attempts to pump anything other than shortening in the liquid state is **not covered under warranty**.

temperature commercial-quality **LIQUID SHORTENING**. This requires 55lbs. of liquid shortening for non-solid shortening melt optioned fryers, and either 55 lb. of liquid or solid shortening for fryers with **SOLID SHORTENING MELT OPTION**. Solid shortening should be packed around elements.

PREPARATION PRIOR TO OPERATION (continued)

Check operation of FRYER and all CONTROLS.

WFAE-55F: See page 15

WFAE-55FS: See page 16

WFAE-55FS w/solid shortening melt option: See page zzzz



WARNING: OIL SPLATTER HAZARD

The weight of product that can safely be cooked in this pressure fryer will vary with oil level, product moisture content and oil temperature.

**FAILURE TO DETERMINE THE SAFE WEIGHT OF PRODUCT
WILL RESULT IN HOT OIL RELEASE FROM THE FRYER
HOT OIL WILL CAUSE SEVERE BURNS ON CONTACT**

Death or serious injury may result from slipping and falling in spilled oil.

IMPORTANT:

For operational safety it is important to determine the maximum load weight for the specific operation:

- Start with small loads
- Gradually increase load size
- Determine the largest load that will allow a full cook cycle without oil foaming out of the frypot.
- Post the maximum load in a conspicuous spot near the fryer.

DETERMINE MAXIMUM LOAD WEIGHT:

For operational safety, it is very important to determine the maximum load weight for the specific operation. This can be accomplished by starting out with small loads and *gradually increasing to the largest load size that will allow a cook cycle to be completed without oil foaming out of the FRYPOT.*

OPERATION - WFAE-55F (MANUAL CONTROLS)

PRE-HEATING FRYER

Make sure FRYPOT is filled with 55 LB. of cooking oil.

Open door and set THERMOSTAT (item 10) to desired cooking temperature. CLOSE THE DOOR.

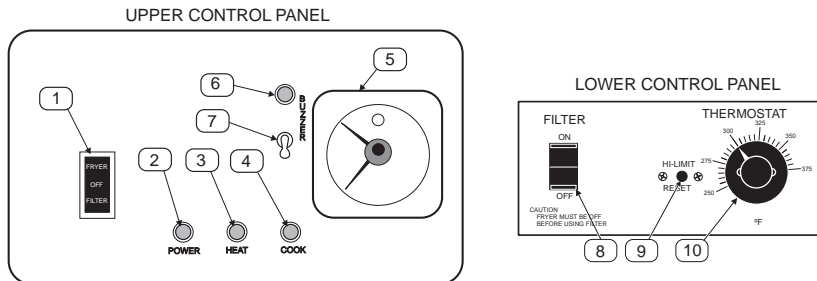

Set POWER SWITCH (item 1) to *FRYER*. POWER LIGHT (item 2) and HEAT LIGHT (item 3) will glow. HEAT LIGHT will cycle on and off with the HEATING ELEMENTS. When HEAT LIGHT first goes off, fryer is ready to cook the product.

SET COOK TIMER AND LOAD PRODUCT

Set TIMER (item 5) to desired cooking time.

FROZEN PRODUCT:

Load frozen product into BASKET. Set BASKET on LIFT CRADLE.

Press RED BUTTON on TIMER to lower BASKET into FRYPOT.

FRESH PRODUCT:

Set BASKET on LIFT CRADLE.

Press RED BUTTON on TIMER to lower BASKET into FRYPOT. Manually drop each piece of fresh product into hot oil, just above the oil level to minimize splattering.

ALWAYS USE PROTECTIVE EQUIPMENT, SUCH AS INSULATED GLOVES, TO PROTECT AGAINST HOT OIL BURNS

COOK CYCLE AND BUZZER

When an audible alarm is desired at end of cook cycle, turn BUZZER SWITCH (item 7) *ON* after TIMER has been started. BUZZER LIGHT (item 6) will glow.

Note: If BUZZER SWITCH is turned *ON* before BASKET is lowered, BUZZER will sound until BASKET has fully lowered.

At end of cook cycle, BASKET will raise. BUZZER will sound until BUZZER SWITCH is turned *OFF*, or until the next cook cycle is started.

Use plastic-coated handles on fry basket to remove basket of cooked product from LIFT CRADLE. Serve or dispense cooked product as required.



CAUTION:
BURN HAZARD

Hot oil can cause serious burns on contact. Wear appropriate protective clothing when using this fryer.

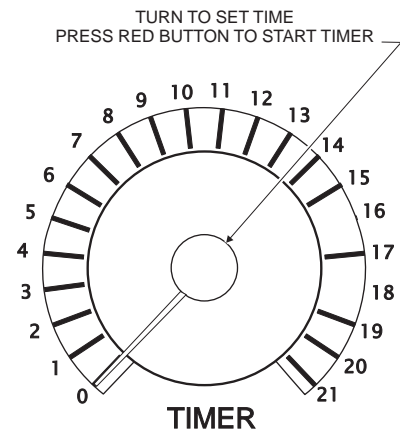

OPERATION - WFAE-55FS (SOLID STATE CONTROLS)



CAUTION: BURN HAZARD

Hot oil can cause serious burns on contact. Wear appropriate protective clothing when using this fryer.

Controller operation for solid shortening melt optioned fryers is essentially identical to the operation of the standard solid state controller. Important differences are noted in the text.

PROGRAMMING KEY FUNCTIONS

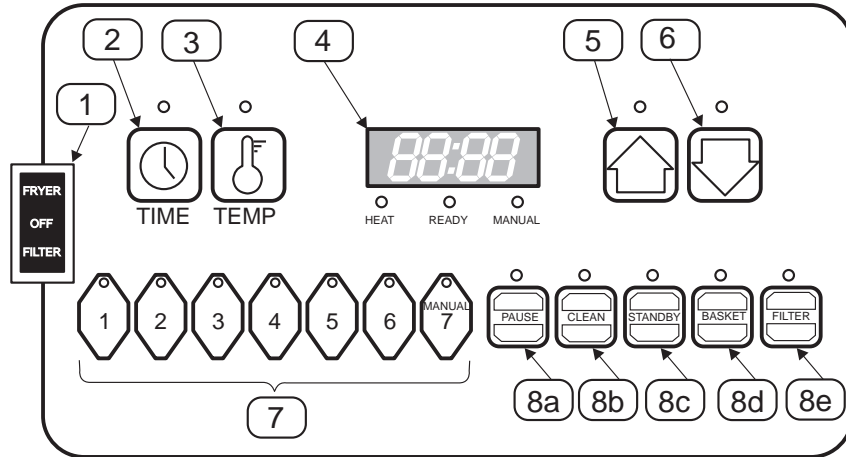

As each control panel key is pressed, a “beep” will sound. Illuminated indicator light for each key will light whenever that key is pressed, and any time the function associated with that key is active.

FRYER - OFF - FILTER switch (item 1) allows the fryer to be placed in a normal cook mode (*FRYER*), an oil-filtering mode (*FILTER*) or turned *OFF*.



TIME key (item 2) controls time functions.

TEMP key (item 3) controls temperature functions. Data can be read on the solid state READOUT (item 4).

HEAT indicator is lit whenever the burners are energized; READY indicator is lit when cooking oil is at programmed temperature. MANUAL indicator is lit whenever MENU key 7 is selected.



Arrow keys (item 5 & 6) control the basket lift (after pressing BASKET key), and are used to scroll through program settings.



MENU keys (item 7) allow a choice of six (or seven) pre-programmed time / temp settings.

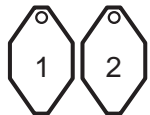

Suggestion: MENU keys 1 and 2 incorporate a feature that will inform the operator when to “drop” wings and drumsticks during cook cycle. “Drop” feature will allow you to cook breasts and thighs longer than wings and drumsticks by sounding a beep, and displaying “DrOP” on readout (item 4). **Your fryer installer can program this feature into your controller upon request.**

Any selected MENU key can be cancelled by pressing and holding for 3 seconds.



MENU key 7 is unprogrammed so that special or one-of-a-kind product may be programmed any time:

With fryer is *ON*, press and hold TIME key and MENU 7 key at the same time.

Press the UP or DOWN arrow key until the desired time is displayed.



If this MANUAL feature is not desired, MENU key 7 may be programmed in the identical fashion to MENU keys 1 thru 6.





PROGRAM MENU TIMES AND TEMPERATURES





For **solid shortening melt optioned fryers**, make sure elements are packed with 55 pounds of solid shortening. For **all other fryers**, make sure FRYPOT is filled with room temperature liquid shortening to the *COLD OIL LEVEL* line inscribed on inside of FRYPOT. Do not over-fill or under-fill frypot. (See page 13.)

Set the POWER SWITCH (item 1) to *FRYER*. After 10 seconds, readout will display "ML^t" (during melt cycle of solid shortening melt optioned fryers only) then "Pre-" "HEAt", followed by the number of the menu currently selected (indicator of selected menu key will be lit). Press  to verify the programmed temperature setting of that menu.

Press any MENU key to change to that menu.

Enter PROGRAMMING mode by pressing and holding  +  for three seconds, until a beep sounds and readout displays "Pro9".



Program MENU key 1 for the pre-determined *cook time* by pressing and holding  +  at the same time. Scroll to the desired time by pressing  or  until desired time is displayed on readout.

Program MENU key 1 for the pre-determined *cook temperature* by pressing and holding  +  at the same time. Scroll to desired temp by pressing  or  until desired temperature is displayed on readout. Range is 200°F - 375°F (93°C - 191°C).

Program MENU keys 2 thru 6 in the same manner.

 can be programmed, or left as a MANUAL menu key.

NOTE: Only  can be programmed while another MENU is cooking.

Exit PROGRAMMING MODE by pressing and holding  +  for one second. Readout will display "00:00" or "PrE-" "HEAt".

IMPORTANT:

To program the controller for cooking your product you must first determine the cooking time and temperature required to cook the product. Each MENU key may be programmed for a different time and temperature, depending upon the requirements of each menu item.

It is the sole responsibility of the end user to determine the time and temperature requirements of each menu item, and to program each MENU key to the determined time and temperature in order to insure completely and safely cooked product.

IMPORTANT:

Be sure to record which MENU key corresponds to which menu item or product to be cooked.

OPERATION - WFAE-55FS (continued)

USING FUNCTION KEYS



PAUSE Halts time countdown while any menu is running and readout displays time remaining.



+



- **Purpose:** Allows the user to raise fry basket to inspect product in the middle of a cook cycle. Time remaining is frozen until PAUSE key is pressed again.
- **To use:** While a menu is running, press and hold PAUSE key for five seconds, until a beep sounds and red indicator near key lights. Raise the basket to inspect product by pressing the BASKET key and UP arrow key. Resume cooking product by pressing BASKET key and DOWN arrow key. Resume time countdown by pressing PAUSE key again.



+



- **To change the time remaining while in pause:**
 - (a) This option uses the near-instant programming feature of MENU 7 (MANUAL) key. Press and hold TIME key plus the MENU 7 key at the same time.
 - (b) Scroll in a new time remaining with the UP or DOWN arrow keys. Release all keys. Press and hold the lit MENU key for three seconds. Remaining time will cancel and display will read "00:00". Lower fry basket by pressing BASKET key followed by DOWN arrow key. Press the MANUAL (MENU 7) key. Time will now countdown from new time programmed into key 7. Basket will rise at end of new time, display reads "00:00".

If the original menu time or temperature must be adjusted, see programming procedure, page 17.



CLEAN puts the fryer into the cleaning mode by setting the temperature to approximately 200°F (94°C) (i.e. just below the boiling point of water).

To Use: See *CLEANING INSTRUCTIONS*, page 27



STANDBY puts fryer into "sleep" mode for off-peak periods.

- **Purpose:** This economy function allows the oil temperature to cool to 275°F (135°C) when the fryer is not in use, but it is not desirable to turn the fryer off.
- **To use:** While no menu is running and the display reads "00:00", press and hold STANDBY key until a "beep" sounds and the red indicator lights. To resume cooking after being in standby mode: Press and hold STANDBY until a "beep" sounds. Heating elements will be energized. Fryer is ready for use when READY light is lit.



BASKET allows UP and DOWN arrow keys to raise or lower fry basket.

- **To Use:** Press and release BASKET key. Red indicators over the basket key and UP arrow and DOWN arrow keys will light. Press and release either arrow key. Selected arrow key indicator will light. All keys will be inactive for ten seconds during the raise/lower cycle. Active only in pre-heat and pause modes, or when display reads "00:00".



FILTER acknowledges filter alarm. The filter alarm is programmed to sound after a pre-set number of cook cycles. **This is factory pre-set to zero cycles. Your fryer installer can alter the number of cycles upon request.**

- **To Use:** When the cycle count reaches the pre-set number, a "beep" will sound. Press and release FILTER key to cancel alarm and reset filter load counter to "zero". See *FILTERING OIL*, page 22.

OPERATION - WFAE-55F (MANUAL CONTROLS)



PRE-HEAT THE FRYER



Press any MENU key. If oil temperature has not reached programmed temperature, readout will display “Pre-” “HEAT”, followed by the menu key #, and HEAT indicator will light. When oil has reached programmed temperature, READY indicator will light, a “beep” will sound five times and readout will display “00:00”. Readout will normally display *time remaining*. To display *oil temperature* of lit menu item, press .

TO COOK PRODUCT

Press a MENU key  for desired menu item.

When oil reaches programmed temperature for that MENU key, READY light will glow, HEAT light will go dark and five “beeps” will sound.

FROZEN PRODUCT: Set FRY BASKET on LIFT CRADLE in the raised position. Load frozen product into BASKET. Lower BASKET by pressing , then . When basket is fully down, start timed cycle by pressing appropriate MENU key. At the end of the timed cycle, basket will raise automatically (and 10 second buzzer will sound).

FRESH PRODUCT: Set empty BASKET on LIFT CRADLE in the raised position. Lower BASKET by pressing , then . Manually drop each piece of fresh product into the hot oil just above oil level to minimize splattering. *ALWAYS USE PROTECTIVE EQUIPMENT, SUCH AS INSULATED GLOVES, TO PROTECT AGAINST BURNS FROM CONTACT WITH HOT OIL.* For chicken, drop thighs and breasts first, followed by drumsticks, then wings. Start a timed cycle by pressing appropriate MENU key.

SUGGESTION: MENU keys 1 and 2 incorporate a feature that will inform the operator when to “drop” the wings and drumsticks during the cooking cycle. DROP feature will allow you to cook breasts and thighs longer than wings and drumsticks by audibly beeping, and displaying “DrOP” on the readout. **Your fryer installer can program this feature into your controller upon request.**



**CAUTION:
BURN HAZARD**

Hot oil can cause serious burns on contact. Wear appropriate protective clothing when using this fryer.

IMPORTANT:

Use the plastic-coated HANDLES of the fry basket to remove basket of cooked product from LIFT CRADLE.

OPERATION - OPTIONAL FILTER WAND

DANGER

DANGER: BURN HAZARD

Contact with hot oil will cause severe burns.

Always wear protective clothing and heat resistant gloves when using the oil wand.

IMPORTANT:

Be sure the wand is properly installed, and that the discharge nozzle of the oil wand is directed either:
into the frypot, or
into the disposal container, before pressing the FRYER-OFF-FILTER switch to the FILTER position.



CAUTION: BURN HAZARD

Contact with hot oil may cause burns. DO NOT fill fryer beyond MAX OIL line on frypot.

For disposal of oil use only a container specifically designed for the disposal of hot oil. DO NOT fill hot oil disposal container beyond MAX OIL line.

NOTE:

If the discharge from the nozzle is not a steady stream, the filter is clogged with breading and/or filter powder:

- Close the frypot drain valve by turning the drain valve handle to the *horizontal* position. When all oil is returned to the frypot, press the FRYER-OFF-FILTER to *OFF*.
- Allow the filter reservoir to cool. Refer to the Operation Manual for instructions on cleaning the filter and filter reservoir.

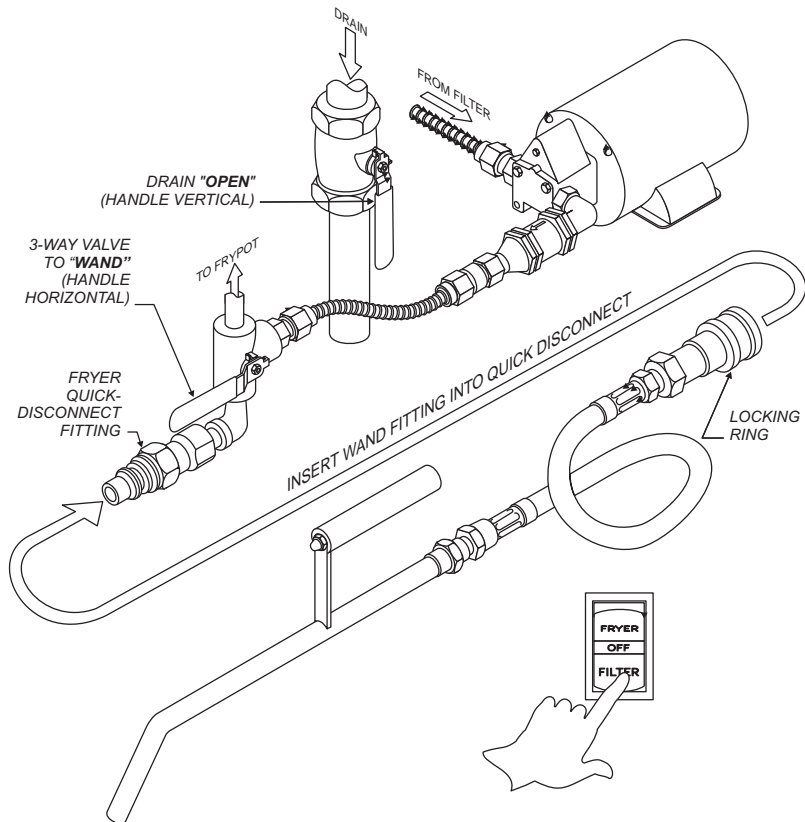

OPTIONAL OIL WAND WASH OUT FRYPOT or DISCARD OIL

- If discarding oil, be sure a suitable hot oil disposal container is available. Otherwise, prepare filter reservoir pan for filtering (see page 25).
- Turn DRAIN VALVE HANDLE *vertical* to open the drain and fill filter reservoir.
- Connect wand (female) fitting to the fryer (male) fitting:
 - Slide locking ring of wand female fitting fully toward the hose.
 - Seat wand fitting fully onto fryer fitting.
 - Allow locking ring to return to its original position.
 - Check to verify that wand fitting is held securely by pulling on the hose. It must NOT "pop" off of fitting.
- Turn 3-WAY VALVE HANDLE to *horizontal* position to direct the pump output to wand.
- Direct discharge nozzle of wand into the frypot, or into a suitable hot oil disposal container. DO NOT fill beyond the MAX OIL line.
- Press FRYER-OFF-FILTER switch to *FILTER* position.
- Wand may be used to wash down sides of the frypot during filtering, or to pump oil into a container for disposal.

OPERATION - OPTIONAL FILTER WAND (continued)

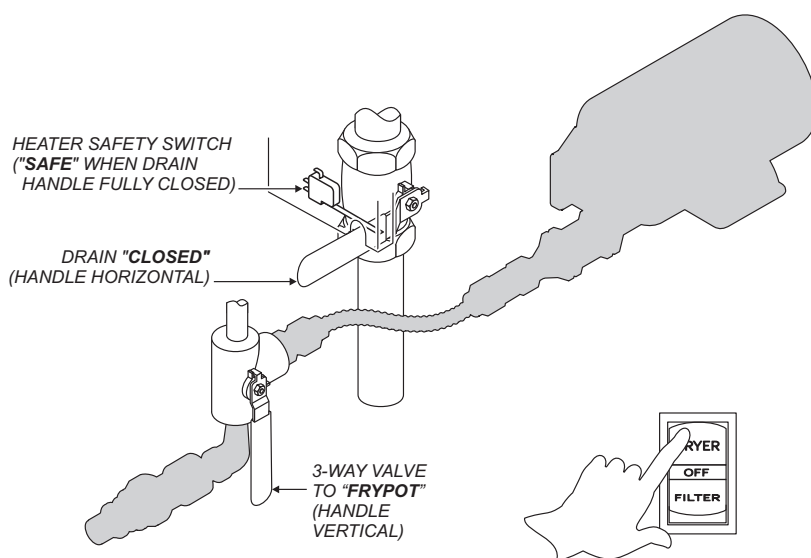

DANGER

DANGER: BURN HAZARD

Contact with hot oil will cause severe burns. Always wear protective clothing and heat resistant gloves when operating the fryer.



CAUTION: BURN HAZARD

Overflow of hot oil may cause burns. DO NOT fill fryer beyond MAX OIL line on frypot.

OPTIONAL OIL WAND RETURN FRYER TO NORMAL OPERATION

1. After washing down frypot, turn DRAIN VALVE HANDLE *horizontal* to close the frypot drain.

IMPORTANT: Drain handle must be fully closed in order to activate HEATER SAFETY SWITCH. Drain handle must be horizontal before for fryer heating element can be energized.

2. At conclusion of use, press FRYER-OFF-FILTER switch to *OFF* position, disconnect wand from fryer fitting and return handle of the 3-WAY VALVE to the vertical position.
3. Drain any remaining oil in wand by pointing discharge nozzle of wand down into frypot or disposal container.
4. Be sure 3-WAY VALVE HANDLE is *vertical*. Press FRYER-OFF-FILTER switch to *FILTER* position. When all oil has been returned to frypot, press FRYER-OFF-FILTER switch to *FRYER* position to resume operation, or to *OFF* position to shut down.

IMPORTANT:

When refilling the frypot, be sure the 3-way valve handle is *vertical*, and the drain valve handle is *horizontal* before pressing FRYER-OFF-FILTER switch to the *FILTER* position.

CLEANING INSTRUCTIONS

DANGER

DANGER: BURN HAZARD

Contact with hot oil will cause severe burns. Allow the fryer to cool before cleaning. Always wear protective clothing and heat resistant gloves when cleaning the fryer.



CAUTION: ELECTRIC SHOCK HAZARD

Disconnect fryer from electric power before cleaning.



CAUTION: BURN HAZARD

Allow fryer to cool completely before cleaning.

IMPORTANT: DO NOT spill or pour water into controls, control panel or wiring.

IMPORTANT: DO NOT use steel wool or abrasive cleansers for cleaning the fryer cabinet or frypot.

PREPARATION

Press POWER SWITCH to *OFF*
Allow fryer to cool completely before cleaning
Disconnect fryer from electric power before cleaning

FREQUENCY

Daily, or as needed

TOOLS

Mild Detergent, Non-abrasive cleanser
Soft Cloth or Sponge, Plastic Scouring Pad

DAILY CLEANING

1. Press POWER SWITCH to *OFF*.
2. Remove FRY BASKET, LIFT CRADLE and FILTER RESERVOIR ASSEMBLY.
IMPORTANT: Clean reservoir only when empty.
3. Allow the oil to cool to a safe temperature (120°F or less).
4. Fry basket and lift cradle may be washed in a dishwasher, or with warm water and mild detergent. Rinse thoroughly and dry completely.
5. Clean FILTER RESERVOIR, FILTER LEAF in the dishwasher, or use warm water with a mild detergent. Be sure all components are thoroughly dry, then reassemble
IMPORTANT: Be sure FILTER LEAF and inside of RESERVOIR SUCTION TUBE are completely dry.
6. Keep all exterior surfaces free from splashed grease by wiping with a clean cloth dampened with warm water and mild detergent.
 - Clean both sides of FRYPOT COVER.
 - Clean side, front and accessible interior areas of cabinet.
 - A non-abrasive detergent and plastic scouring pad may be used for stubborn deposits.
 - Dry with a soft clean cloth.**IMPORTANT:** DO NOT use steel wool or abrasive cleansers as these will damage the surface finish.
IMPORTANT: DO NOT spill or pour water into controls, control panel or wiring. Damage to internal components will occur.
7. Reinstall LIFT CRADLE, FRY BASKET and FILTER RESERVOIR ASSEMBLY.

Procedure is complete.

CLEANING INSTRUCTIONS (continued)

WFAE-55F (Manual Controls) HOT BOIL-OUT PROCEDURE



WARNING: BURN HAZARD

TURN THERMOSTAT TO LOWEST TEMPERATURE SETTING
(FULLY COUNTERCLOCKWISE)

USE ONLY LOW-FOAMING COMMERCIAL FRYER CLEANSER.
CAREFULLY FOLLOW CLEANSER INSTRUCTIONS AND WARNINGS.

DO NOT LEAVE FRYER UNATTENDED
WHILE BOILING OUT FRYPOT.

WHEN WATER BEGINS FOAMING,
BE PREPARED TO TURN POWER SWITCH OFF.

Boiling water and splatter can result in moderate to serious injury.

PREPARATION	Drain oil from fryer before cleaning
FREQUENCY	Monthly, or as needed
TOOLS	Low-foaming commercial fryer cleanser Metal disposal container

IMPORTANT:
Use a LOW-FOAMING
COMMERCIAL fryer cleanser
only.

IMPORTANT:
DO NOT press FRYER-OFF-
FILTER SWITCH to *FILTER*
with anything other than
shortening in the filter
reservoir. Water and/or
cleaning chemicals can:

- cause severe oil splatter
- damage the filter pump
- contaminate cooking oil
and food product.

Press POWER SWITCH OFF.

Close DRAIN VALVE (lever horizontal). Fill FRYPOT with 4 gallons of cold water.

Press POWER SWITCH to *FRYER*.

When water comes to a full boil, press POWER SWITCH OFF. When boiling ceases, slowly add and stir in the *LOW FOAMING COMMERCIAL FRYER CLEANSER*. Using the HIGH TEMPERATURE BRUSH supplied with the fryer, stir until the cleanser is completely dissolved.

Press POWER SWITCH to *FRYER*. When the water begins to boil, press POWER SWITCH OFF. When the boiling subsides, again press POWER SWITCH to *FRYER*. Repeat this procedure continuously for five (5) minutes.

Press POWER SWITCH OFF. Allow the solution to set for thirty (30) minutes.

Allow solution to cool to 120°F (49°C) or less before draining.

Place a suitable METAL container under the DRAIN VALVE. Open DRAIN VALVE (lever vertical) to drain the cleaning solution.

NOTE: Drain no more than 4" at a time into the container to prevent splashing and spilling. Dispose of used solution as required by local ordinances.

Rinse frypot with clean water. Dry with a soft clean cloth.

CLEANING INSTRUCTIONS (continued)

WFAE-55FS (Solid-State Controls) HOT BOIL-OUT PROCEDURE



WARNING: BURN HAZARD

USE THE **CLEAN** BUTTON ONLY

USE ONLY LOW-FOAMING COMMERCIAL FRYER CLEANSER.
CAREFULLY FOLLOW CLEANSER
CLEANING INSTRUCTIONS AND WARNINGS

DO NOT LEAVE FRYER UNATTENDED WHILE BOILING OUT FRYPOT.

BE PREPARED TO TURN POWER SWITCH OFF SHOULD WATER BEGIN FOAMING
Boiling water can splatter and may cause serious injury

IMPORTANT:

Use a LOW-FOAMING COMMERCIAL fryer cleanser only.

IMPORTANT:

DO NOT press FRYER-OFF-FILTER SWITCH to *FILTER* with anything other than shortening in the filter reservoir. Water and/or cleaning chemicals can:

- cause severe oil splatter
- damage the filter pump
- contaminate cooking oil and food product.



PREPARATION

Drain oil from fryer before cleaning

FREQUENCY

Monthly, or as needed

TOOLS

Low-foaming commercial fryer cleanser
Metal disposal container

Press POWER SWITCH *OFF*.

Close DRAIN VALVE (lever horizontal).
Fill FRYPOT with 4 gallons of cold water.

Press POWER SWITCH to *FRYER*.

Wait 10 seconds, then press and hold *CLEAN* button for six seconds. A beep will sound and readout will display "BOIL".

Slowly add and stir in the *LOW FOAMING COMMERCIAL FRYER CLEANSER*. Using the HIGH TEMPERATURE BRUSH supplied with the fryer, stir until the cleanser is completely dissolved.

Time displayed is elapsed time. When display reads "1:30", press POWER SWITCH *OFF*. Allow the solution to cool to 120°F or less.

Place a suitable METAL container under the DRAIN VALVE. Open DRAIN VALVE (lever vertical) to drain the cleaning solution.

NOTE: Drain no more than 4" at a time into the container to prevent splashing and spilling. Dispose of used solution as required by local ordinances.

Rinse frypot with clean water. Dry with a soft clean cloth.

MAINTENANCE INSTRUCTIONS - FILTER SYSTEM

FILTER LEAF ASSEMBLY



WARNING: BURN HAZARD

HOT OIL SPILL OR SPLATTER

DO NOT REMOVE FILTER RESERVOIR WHEN IT CONTAINS HOT OIL
HOT OIL WILL CAUSE SEVERE BURNS ON CONTACT
PROTECTIVE CLOTHING AND GLOVES MUST BE WORN
DURING THE FILTERING PROCESS

Death or serious injury may result from contact with, or slipping and falling in, spilled oil.



WARNING: BURN HAZARD

DO NOT REMOVE FILTER RESERVOIR IF IT IS HOT.
WEAR INSULATED GLOVES OR ALLOW IT TO COOL.

Hot oil quickly heats reservoir. Touching hot reservoir with bare hands can causing serious injury

Clean FILTER LEAF after each day's filtration, or as needed to return oil promptly to the kettle.

Open FRYER DOOR and slide the FILTER RESERVOIR forward to remove it. Remove FILTER LEAF from reservoir.

Disassemble FILTER LEAF by separating the two side rails at the joint with the straight pin. Clean all components in a sink with warm water and mild detergent, or in a dishwasher.

Assemble SCREEN with the SEPARATOR installed between the two screens. Verify that O-RING is in place on the suction tube on BOTTOM SCREEN.

Slide screens into SIDE RAIL "B" (L-shaped pin). Hook SIDE RAIL "A" over the pin on SIDERAIL "B" and work the screens into SIDE RAIL "A" until straight pin on "A" is held by the "bump" on "B".

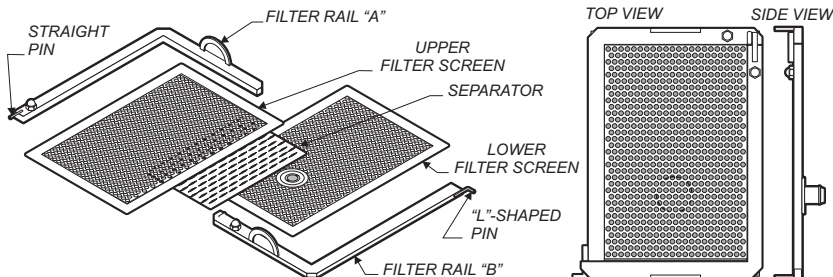

Install FILTER LEAF in RESERVOIR with suction tube firmly into filter drain hole.

Install filter reservoir into the fryer. Make sure the "O" ring closest to end of SUCTION TUBE is firmly seated in SUCTION LINE RECEPTACLE.

IMPORTANT: Make sure all oil is pumped into FRYPOT before removing reservoir.

NOTE:

When properly assembled, handle will point away from suction tube on BOTTOM SCREEN.

NOTE:

Inspect the "O" RING on FILTER SUCTION TUBE for damage. Replace "O" ring if it is cut, cracked or scuffed using one of the spare o-rings in the suction tube groove.

IMPORTANT:

Avoid contaminating the oil or food product by verifying that all components of filter reservoir assembly are completely dry before reassembling.

MAINTENANCE - FILTER SYSTEM (continued)

FILTERING OIL



WARNING: BURN HAZARD

BE ABSOLUTELY CERTAIN THAT NO WATER REMAINS
IN RESERVOIR OR SUCTION TUBE

WATER WILL BOIL VIOLENTLY IN CONTACT WITH HOT OIL
Boiling water can splatter hot oil and may cause serious injury

NOTE:

Oil should be at least 300°F (149°C) DO NOT attempt to filter cold oil. DO NOT attempt to pump oil when less than 300°F. Cold oil will not pass through the filter paper. Filtering cold oil will result in the premature failure of the filter pump. Damage as a result of pumping cold oil IS NOT COVERED BY WARRANTY.

NOTE:

DO NOT store oil in the reservoir for any extended period, including overnight.

IMPORTANT:

The filtration system in your Wells Fryer is designed to filter hot liquid shortening ONLY. Water, cleaning agents or other liquids will damage the filter pump and may contaminate the food product

Press POWER SWITCH (item 1) to *FILTER*. Pump motor will be energized and heating elements are de-energized.

Remove and examine filter reservoir:

- Verify that filter leaf is clean and properly installed.
- Verify that suction tube o-ring is in place and in good condition.
- Make absolutely certain that no water remains in bottom of reservoir or in suction tube.

Reinstall reservoir, making sure the SUCTION TUBE is firmly seated in the SUCTION RECEPTACLE.

Press FILTER PUMP SWITCH (item 8) to *ON* to start filter pump.

Slowly rotate DRAIN VALVE LEVER (item 11) to the vertical position. Oil will drain from the frypot and into the reservoir. Filter pump will draw oil through the filter leaf and return it to the frypot.



CAUTION BURN HAZARD

Protective clothing and gloves must be worn during the filtering process



CAUTION BURN HAZARD

Filter reservoir may be hot. Wear insulated gloves, or allow reservoir to cool, before touching it.

IMPORTANT:

Filtering cooking oil helps to ensure the quality of the food product. Careful observation of the finished food product will help you determine the optimal filtering frequency. (Example: Filter the oil after each six loads of fresh breaded chicken)

FILTER POWDER absorbs acids and many other contaminants in the cooking oil, allowing the oil to be used longer before it must be replaced. Wells Flavor Saver Oil Filter Powder is available from your Wells Equipment Dealer or Authorized Service Agent in a case of 45 packages (p/n 22410).



WARNING: BURN HAZARD

WEAR PROTECTIVE CLOTHING AND INSULATED GLOVES WHEN CLEANING FRYPOT WITH HI-TEMP BRUSH AND WHEN CLEARING DRAIN WITH WOOD CLEANOUT DOWEL.

Frypot and oil will be hot. Hot oil may splatter. Contact with hot oil can cause serious injury

Carefully and slowly add the contents of one package of FILTER POWDER to the oil in the frypot. Sprinkle filter powder onto surface of the oil at point where it is being drawn down the drain.

Brush down sides and bottom of frypot using provided hi-temperature brush. Loosen crumbs and other debris to flush them into reservoir.

Use the provided WOOD DOWEL to clear clogs in the frypot drain. Push dowel down through drain hole in the front center of the frypot..

Rotate DRAIN VALVE LEVER (item 11) to the horizontal position when filtering is complete,

Observe the oil returning to frypot. When bubbles appear, wait approximately 15 seconds, then press FILTER PUMP SWITCH OFF.

Verify that all oil has been returned to frypot at end of filtering cycle. Then, press POWER SWITCH to either:

- a. *FRYER* position to resume cooking; or,
- b. *OFF* position to service filter or shut-down fryer.

IMPORTANT:

DO NOT leave the fryer unattended during the filtering process. Continuously monitor oil level in the reservoir to avoid overflowing reservoir and spilling oil on the floor. Be prepared to turn the drain valve lever clockwise to stop or regulate the flow of oil.

IMPORTANT:

Verify that all oil has been returned to frypot at end of filtering cycle.

IMPORTANT:

Crumbs and other debris left in the filter reservoir can prevent filter leaf from sealing completely. This will cause incomplete filtration.

MAINTENANCE - DISCARDING USED OIL



WARNING: BURN HAZARD

OIL MUST COOL TO BELOW 120°F (49°C)
BEFORE DRAINING OIL FROM FRYER FOR DISPOSAL
Normal operating temperature of the fryer is 375°F (191°C)
Contact with hot oil can cause serious injury



WARNING: SLIP AND FALL HAZARD

DO NOT USE FILTER RESERVOIR TO DISCARD OIL
USE A METAL CONTAINER TO COLLECT OIL FOR DISPOSAL
DO NOT FILL DISPOSAL CONTAINER MORE THAN ½ FULL
Do not leave fryer unattended when draining oil
Oil spills may occur

Death or serious injury may result from contact with, or slipping and falling in, spilled oil.



WARNING: BURN HAZARD

DO NOT REMOVE FILTER RESERVOIR IF IT IS HOT.
WEAR INSULATED GLOVES OR ALLOW IT TO COOL.

Hot oil quickly heats reservoir. Touching hot reservoir
with bare hands can causing serious injury

IMPORTANT NOTE:

These instructions for discarding used oil may be disregarded if you are using WELLS MOBILE OIL CADDY WOC-1 (p/n 22470).

The WAOC-1 is a manual oil pump/removal system that allows you to pump used oil directly into the caddy, and then to pump the used oil into your oil disposal container simply by reversing pump direction.

REMEMBER:

Always follow the directions provided with the caddy. WAOC-1 is designed to handle COLD oil. Always, and without fail, allow the oil to cool to 120°F or less prior to pumping. **HOT OIL WILL BURN YOU!**

Press POWER SWITCH to OFF. Allow oil to cool to 120°F (49°C) or less before attempting to drain oil from fryer.

Using suitable gloves, remove 1-1/4 NPT x 5-7/8" DRAIN PIPE from DRAIN VALVE. Store this item in a convenient place.

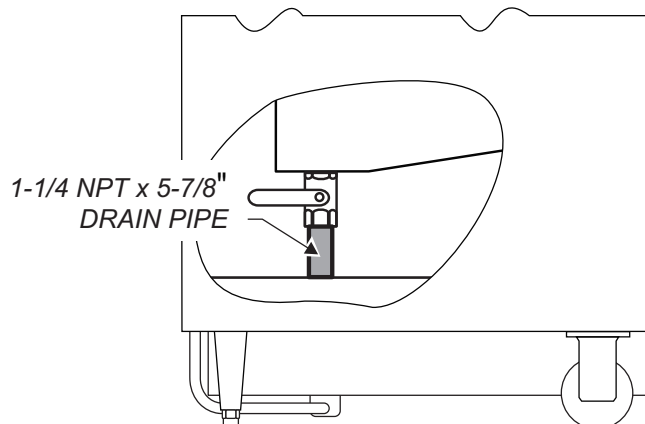

MAINTENANCE - DISCARDING USED OIL (continued)

Screw provided 1-1/4 NPT STREET ELBOW into DRAIN VALVE.
Position female end to point forward.

Screw provided 1-1/4 NPT x 12" DRAIN PIPE into elbow. Hand tight is sufficient.

Place a suitable METAL OIL DISPOSAL CONTAINER under DRAIN PIPE.

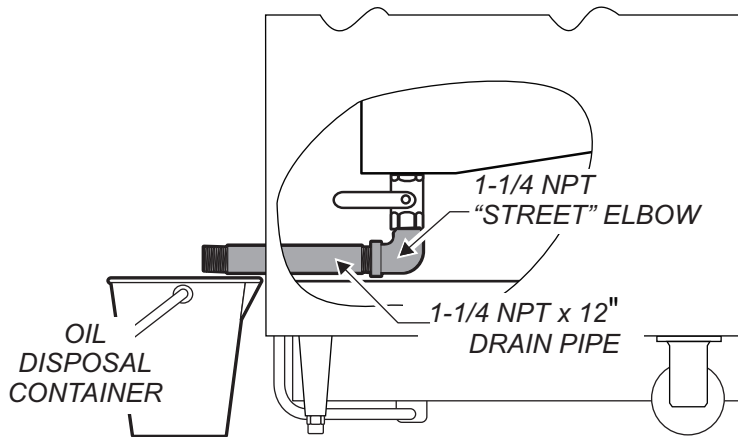

Slowly turn DRAIN VALVE LEVER down toward the OPEN (vertical) position. Fill the container no more than 1/2 full.

Close the DRAIN VALVE and allow oil to finish draining from pipe before removing container. Dump used oil into your WASTE OIL CONTAINER. Continue this process until frypot is empty.

Close the DRAIN VALVE by rotating DRAIN VALVE LEVER up to the CLOSED (horizontal) position.

Using suitable gloves, unscrew 1-1/4 NPT x 12" DRAIN PIPE from ELBOW. Unscrew ELBOW from DRAIN VALVE. Store these items in a convenient place.

Reinstall the 1-1/4 NPT x 5-7/8" DRAIN PIPE into the DRAIN VALVE.

Clean up any spilled oil.

IMPORTANT:

Remember to fill frypot to the COLD OIL LINE with fresh liquid shortening prior to turning POWER SWITCH to *FRYER*. Energizing the fryer without oil covering the elements will cause serious damage. Damage due to operating fryer without oil covering elements is NOT covered by warranty.

MAINTENANCE INSTRUCTIONS - CRADLE LIFT

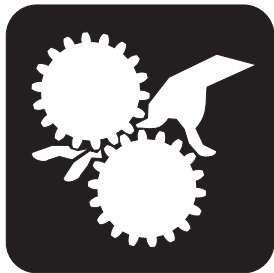

WARNING: PINCH HAZARD

DISCONNECT FRYER FROM ELECTRIC POWER BEFORE LUBRICATING CRADLE LIFT DRIVE SCREW

If power is not disconnected, lift motor may start unexpectedly, causing serious injury

NOTE:

Failure to keep the cradle lift screw properly lubricated will result in premature wear of the brass lift nut. Wear caused by lack of proper lubrication is NOT covered by warranty.

Recommended frequency is "as required", and, at a minimum, every six months. Lubricate cradle lift screw immediately if a grinding or rubbing noise is heard when basket is raising.

NOTE:

Smooth operation of the rollers is essential to the life of the frypot. If rollers do not turn freely during operation, they will soon wear grooves through the frypot wall.

IMPORTANT:

IF ROLLERS ARE FROZEN OR OTHERWISE FOUND TO NOT SPIN FREELY AFTER BEING THOROUGHLY CLEANED, REPLACE THEM IMMEDIATELY.

Wear to the FRYPOT caused by frozen rollers is not covered by warranty.

CRADLE LIFT LUBRICATION

Disconnect the fryer from electrical power.

Open rear access panel. Coat exposed threads of cradle lift screw with moly (molybdenum disulfide) grease.

Close access panel and restore electrical power.

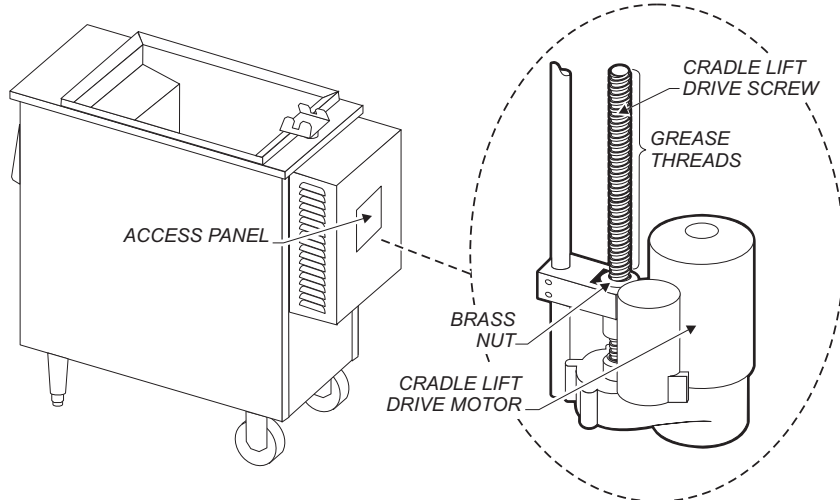

CRADLE ROLLER ASSEMBLIES

DAILY: Wash cradle in a dishwasher or in a sink with warm water and mild soap or detergent.

Thoroughly flush roller bearings with hot water (under a faucet or with a spray nozzle).

Rinse cradle thoroughly and dry completely.

Check rollers to be sure they roll freely.

Check the bearing nuts.
KEEP THEM TIGHT!

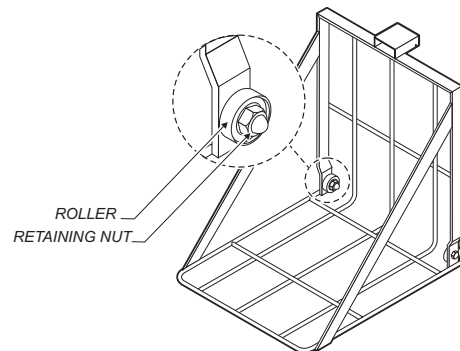

TROUBLESHOOTING - WFAE-55F (Manual Controls)

SYMPTOM	POSSIBLE CAUSE	SUGGESTED REMEDY
Fryer will not heat	Unit disconnected from electric power	Reconnect to power Check/reset circuit breaker
	Temp control thermostat (item 10) not set	Set thermostat to desired temperature
	Hi-Limit thermostat (item 9) tripped	Allow unit to cool, reset hi-limit See page 3
	Drain valve not closed (wand-equipped units only)	Be sure drain handle is fully horizontal
	Internal damage	Contact your Authorized Wells Service Agency for repairs
Lift cradle will not lower	Timer not set or not activated	Set timer to other than "0", press red button to lower cradle.
	Internal damage or mis-adjustment	Contact your Authorized Wells Service Agency for repairs
Lift cradle will not raise	Lift cradle not properly assembled to lift rod	Properly assemble cradle pivot to lift rod
	Internal damage or mis-adjustment	Contact your Authorized Wells Service Agency for repairs
Filter pump will not run	Switches not set for filtering	Press power switch (item 1) to <i>FILTER</i> Press pump filter switch (item 6) to <i>ON</i>
	Pump overload (item 9) tripped	Reset overload. Press red button until it "clicks" and stays locked in
	Internal damage (pump overload trips frequently)	Contact your Authorized Wells Service Agency for repairs
Filter reservoir overflows during filter cycle	Drain valve (item 11) not properly set	Oil level in reservoir must be monitored at all times while filtering. Adjust flow by opening or closing drain valve
	Filter leaf surface clogged with crumbs or other cooking debris	Turn drain valve <i>OFF</i> . When bubbles begin appearing in frypot turn filter pump switch <i>OFF</i> . Carefully slide reservoir out 12" and clear surface of filter leaf with hi-temp brush or wooden dowel. Reinstall reservoir and resume filtering.
Does not filter completely	Filter leaf not properly assembled or not properly installed	Reassemble filter leaf. Be sure o-ring is in place, o-ring receptacle is clean and filter leaf is properly installed in reservoir.
	Filter leaf screen damaged	Replace filter leaf
	Filter leaf o-ring damaged	Replace filter leaf o-ring
Filter pump won't pump, or pumps air when filtering	Suction tube not seated, allowing air to enter system	When inserting filter reservoir be sure suction tube is fully seated in suction line receptacle.
	Suction tube o-ring damaged	Replace suction tube o-ring
	Internal damage	Contact your Authorized Wells Service Agency for repairs

NOTE: There are no user serviceable components in the fryer. In all cases of damage or malfunction, contact your Authorized Wells Service Agency for repairs.

TROUBLESHOOTING - WFAE-55FS (Solid State Controls)

SYMPTOM	POSSIBLE CAUSE	SUGGESTED REMEDY
Fryer will not heat	Unit disconnected from electric power	Reconnect to power Check/reset circuit breaker
	Menu temp not programmed or set too low	Program menu key for desired temperature
	Hi-Limit thermostat (item 9) tripped	Allow unit to cool, reset hi-limit See page 3
	Internal damage	Contact your Authorized Wells Service Agency for repairs
Lift cradle will not lower	Menu key not programmed for time, or programmed to 00:00	Program menu key for desired time. Be sure to press <i>BASKET + DOWN</i> to lower basket.
	Internal damage or mis-adjustment	Contact your Authorized Wells Service Agency for repairs
	PAUSE pressed	Be sure to press <i>BASKET + DOWN</i> to lower basket. Press <i>PAUSE</i> when basket is down to resume
Lift cradle will not raise	Lift cradle not properly assembled to lift rod	Properly assemble cradle pivot to lift rod
	Internal damage or mis-adjustment	Contact your Authorized Wells Service Agency for repairs
Filter pump will not run	Switches not set for filtering	Press power switch (item 1) to <i>FILTER</i> Press pump filter switch (item 6) to <i>ON</i>
	Pump overload (item 9) tripped	Reset overload. Press red button until it "clicks" and stays locked in
	Internal damage (pump overload trips frequently)	Contact your Authorized Wells Service Agency for repairs
Filter reservoir overflows during filter cycle	Drain valve (item 11) not properly set	Oil level in reservoir must be monitored at all times while filtering. Adjust flow by opening or closing drain valve
	Filter leaf surface clogged with crumbs or other cooking debris	Turn drain valve <i>OFF</i> . When bubbles begin appearing in frypot turn filter pump switch <i>OFF</i> . Carefully slide reservoir out 12" and clear surface of filter leaf with hi-temp brush or wooden dowel. Reinstall reservoir and resume filtering.
Does not filter completely	Filter leaf not properly assembled or not properly installed	Reassemble filter leaf. Be sure o-ring is in place, o-ring receptacle is clean and filter leaf is properly installed in reservoir.
	Filter leaf screen damaged	Replace filter leaf
	Filter leaf o-ring damaged	Replace filter leaf o-ring
Filter pump won't pump, or pumps air when filtering	Suction tube not seated, allowing air to enter system	When inserting filter reservoir be sure suction tube is fully seated in suction line receptacle.
	Suction tube o-ring damaged	Replace suction tube o-ring
	Internal damage	Contact your Authorized Wells Service Agency for repairs

NOTE: There are no user serviceable components in the fryer. In all cases of damage or malfunction, contact your Authorized Wells Service Agency for repairs.

EXPLODED VIEW: WFAE55F/FS

WFAE-55F (MANUAL CONTROLS) ELECTRICAL COMPONENTS

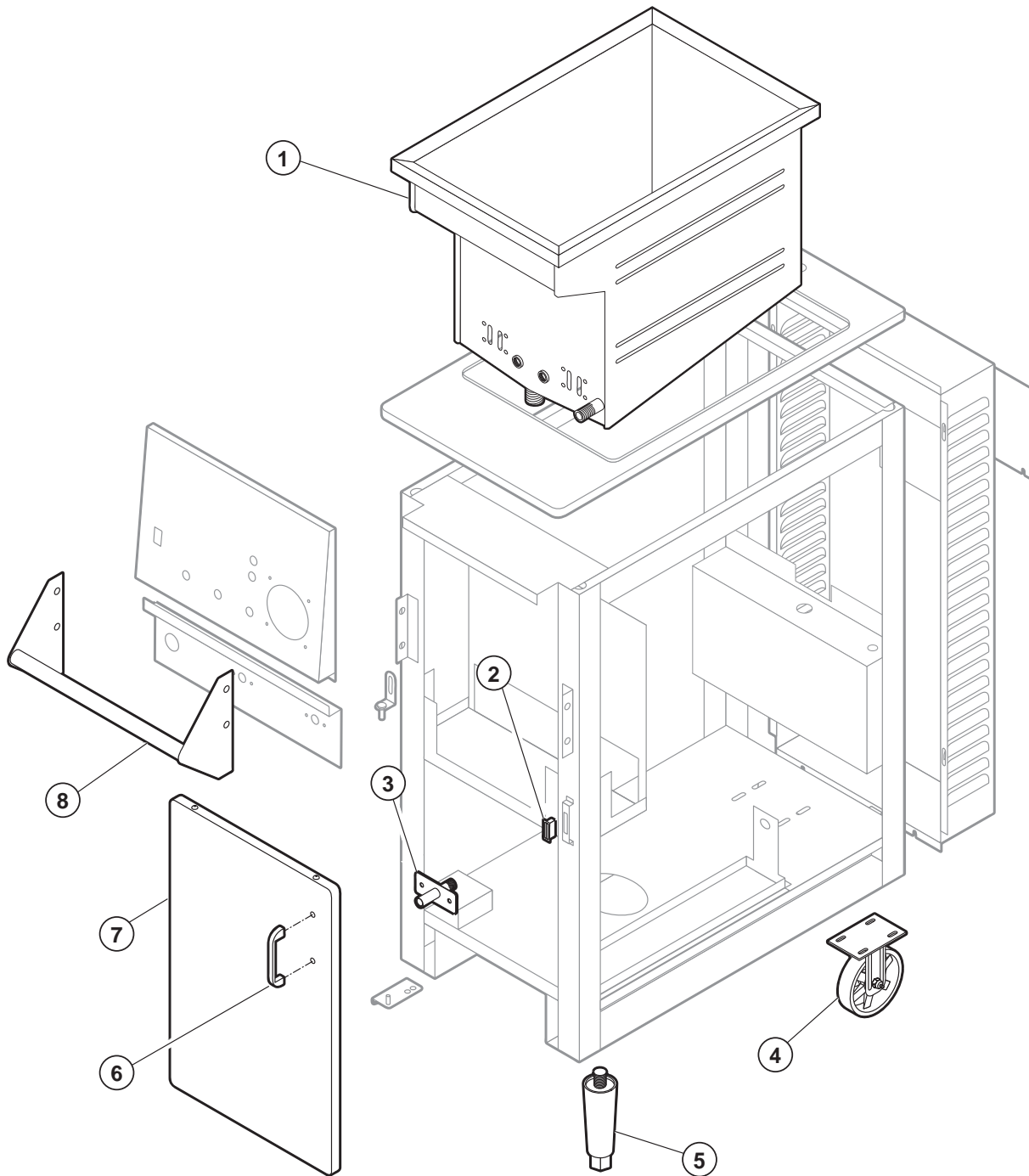

NOT SHOWN
PANEL, RIGHT SIDE E7-46722
PANEL, LEFT SIDE E7-46723

Model: WFAE55F/FS
Free Standing Electric Fryer
Cabinet Components
PL363



IL1764 Rev. A 5/7/09

363 2M-300007 Owners Manual WFAE-55F/FS Free-Standing Electric Fryer

**WFAE-55F/FS ELECTRIC OPEN FRYPOT
CABINET COMPONENTS**

Fig No	Part No	Qty	Description
1	E7-49729	1	KETTLE ASSY WFAE55
	M3-301462		KETTLE ASSY WVAE-55
2	2R-46502	1	MAGNET DOOR
3	E7-46720	1	SUCTION LINE FITTING ASSY
4	2P-47011	2	CASTER RIGID 5"
5	2A-46480	2	LEG 6-7 1/4" ADJUSTABLE
6	2R-38668	1	HANDLE DOOR
7	E7-41713	1	DOOR ASSY WFE WFAE30/WFPE
8	E7-300527	1	GUARD ROD ASSY WFAE55/30
NI	E7-46722	1	PANEL SIDE RT WFAE55/30
NI	E7-46723	1	PANEL SIDE LF WFAE55/30

EXPLODED VIEW: WFAE55F/FS

WFAE-55F (MANUAL CONTROLS) ELECTRICAL COMPONENTS

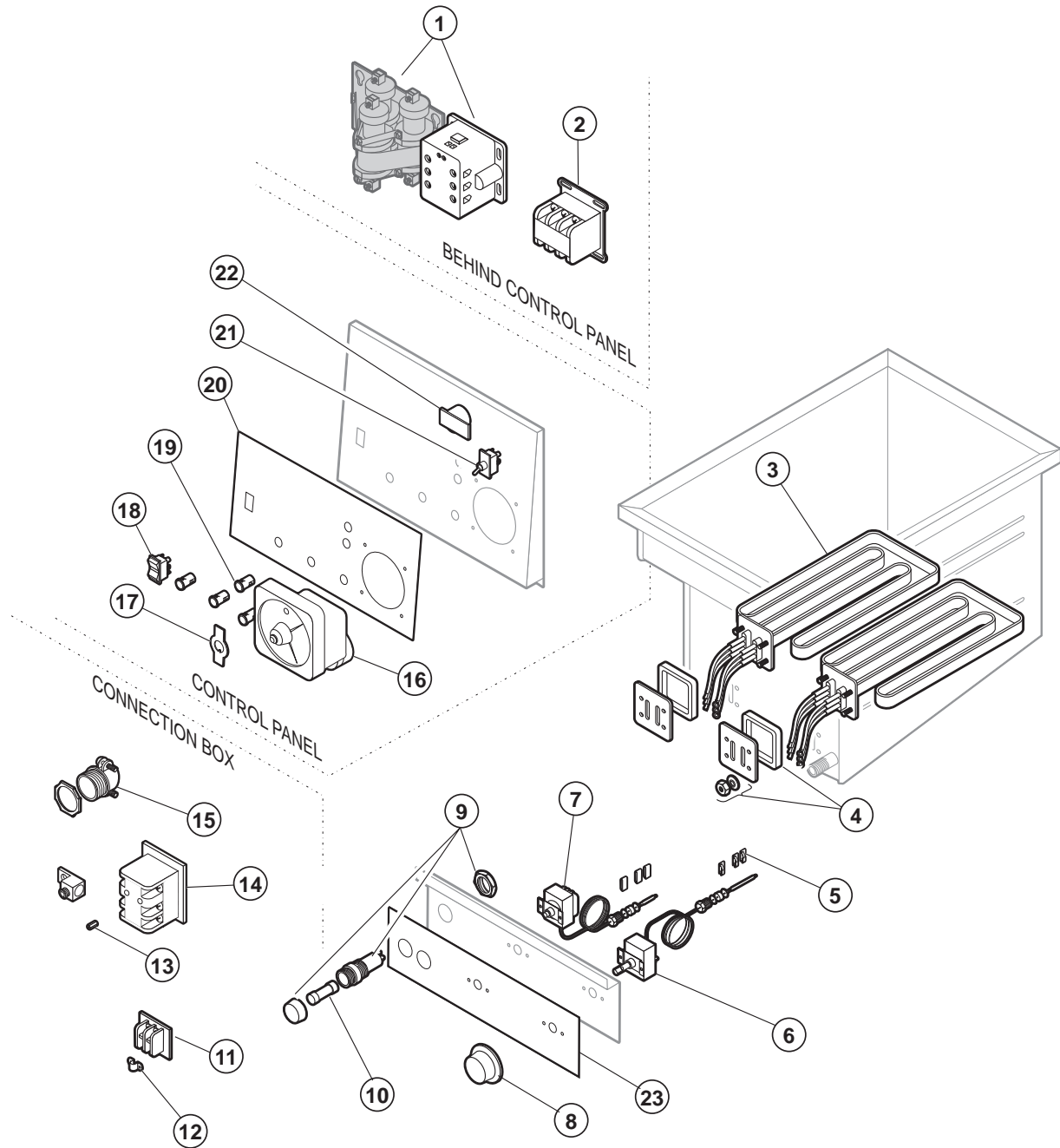

Model: WFAE55F/FS
Free Standing Electric Fryer
Electrical Components (Manual Controls)
PL363



IL1765 Rev. B 6/22/10

363 2M-300007 Owners Manual WFAE-55F/FS Free-Standing Electric Fryer

**WFAE-55F/FS ELECTRIC OPEN FRYPOT
ELECTRICAL COMPONENTS (MANUAL CONTROL)**

Fig No	Part No	Qty	Description
1	2E-306967B	1	RLY ESFEII, I/O 208/240V
2	WS-57779	1	CONTACTOR 3POLE 208V 40A
3	E7-300009	2	ELEM ASSY 208V 8.5KW
3	2N-300013	2	ELEM ASSY 240V 8.5KW
4	WS-66863	1	GASKET KIT ELEM
5	2C-49689	6	CLAMP BULB SS
6	WS-66688	1	THERMO TEMP CTRL
7	WS-66663	1	THERMO HIGH LIMIT
8	2R-45653	1	KNOB CONTROL 2.25 OD .25
9	2E-34769	2	FULEHLDR HPG-EE 10A 240V
10	2E-34768	2	FUSE SC-10 10A 300V
11	WS-53068	1	TERM BLOCK 2POLE
12	2E-34005	1	JUMPER FLAME SENSOR TERM
13	2C-41974	2	NUT 8-32 HEX 7/8 LONG ALU
14	WS-50131	1	TERM BLOCK KIT (RETRO)
15	2K-300102	1	STRAIN RELIEF INPT .375-1
16	2P-Z13854	1	TIMER 40MIN 240V DPST
17	2E-33192	1	PANEL, ON & OFF SWITCH
18	2E-49550	1	SWITCH ROCKER POWER
19	2J-30516	4	LIGHT SIGNAL AMBERR
20	2M-302391	1	FACEPLATE CONTROL WELLS
21	2E-44904	1	SWITCH TOGGLE W/SEAL
22	2J-44834	1	BUZZER 220V ROHS
23	2M-Z13237	1	GRAPHIC LOWER 55F

EXPLODED VIEW: WFAE55F/FS

WFAE-55FS (SOLID-STATE CONTROLLER) ELECTRICAL COMPONENTS

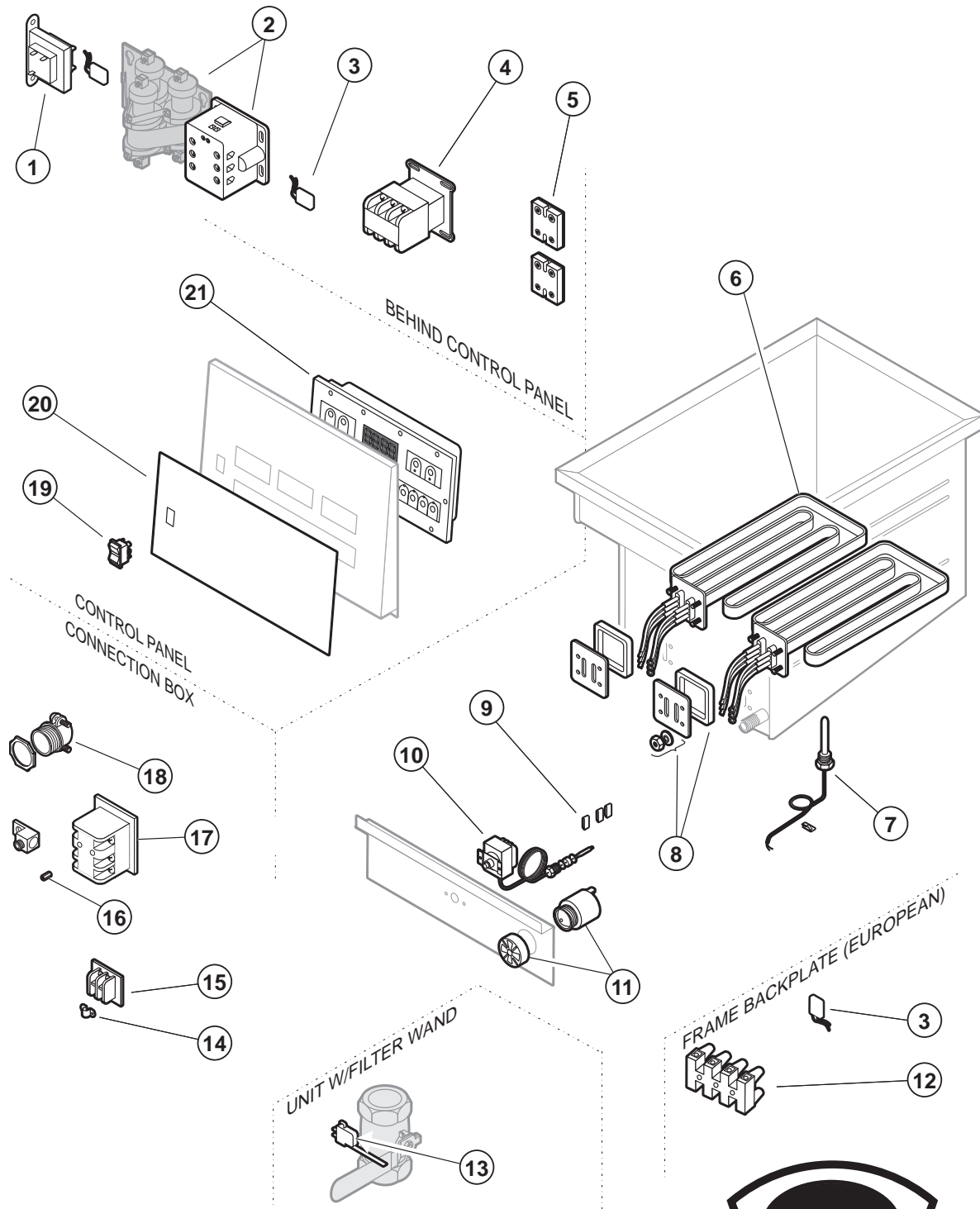

Model: WFAE55F/FS
 Free Standing Electric Fryer
 Electrical Components (Solid-State Controller)

PL363



IL1766 Rev. A 5/7/09

WFAE55F/FS ELECTRIC OPEN FRYPOT ELECTRICAL COMPONENTS (SOLID STATE CONTROL)			
Fig No	Part No	Qty	Description
1	2E-301454	1	TRANSFORMER 208/240V 24V
2	2E-306967B	1	RLY ESFEII, I/O 208/240-HV
3	2E-300688	1/3	SPARK QUENCHER
4	WS-57779	1	CONTACTOR 3POLE 208V 40A
	WS-57780		CONTACTOR 3POLE 240V 40A
5	2E-301200	2	RELAY SOLID STATE 240V
6	2N-306258UL	2	ELEM 208V 5.67KW WFAE, 1 PH
	E7-300009		ELEM ASSY 208V 8.5KW, 3 PH
	2N-306259UL		ELEM 240V 5.67KW WFAE, 1 PH
	2N-300013		ELEM ASSY 240V 8.5KW WFAE, 3PH
7	2J-301465	1	PROBE THERMOSTAT
8	WS-66863	2	GASKET KIT, ELEMENT
9	2C-49689	6	CLAMP BULB SS F49RT F58RT
10	WS-66663	1	THERMO HI-LIMIT
11	2E-300974	1	SOLALERT
12	2E-40310	1	TERM BLOCK 4POLE 75AMP
13	2E-44887	1	SWITCH MICRO 120V 15A
14	2E-34005	1	JUMPER FLAME SENSOR TERM
15	WS-53068	1	TERM BLOCK 2POLE
16	2C-41974	2	NUT 8-32 HEX 7/8 LONG ALU
17	WS-50131	1	TERM BLOCK KIT (RETRO)
18	2K-300102	1	STRAIN RELIEF 1NPT .375-1
19	2E-49550	1	SWITCH ROCKER POWER
20	2M-302417	1	FACEPLATE CONTROLLER FS
21	PS-WL0050*	1	SERV KIT-CONTROL WVAE55, 208/240V, 1PH
	2J-302968		CONTROLLER COOK NON-ROHS, 380V
	2J-307814		CONTROLLER COOK WFAE55, 208/240V, 1PH

* USE KIT IF UNIT HAS OLD MERC RELAY

EXPLODED VIEW: WFAE55F/FS

WFAE-55F/FS FILTER PUMP COMPONENTS

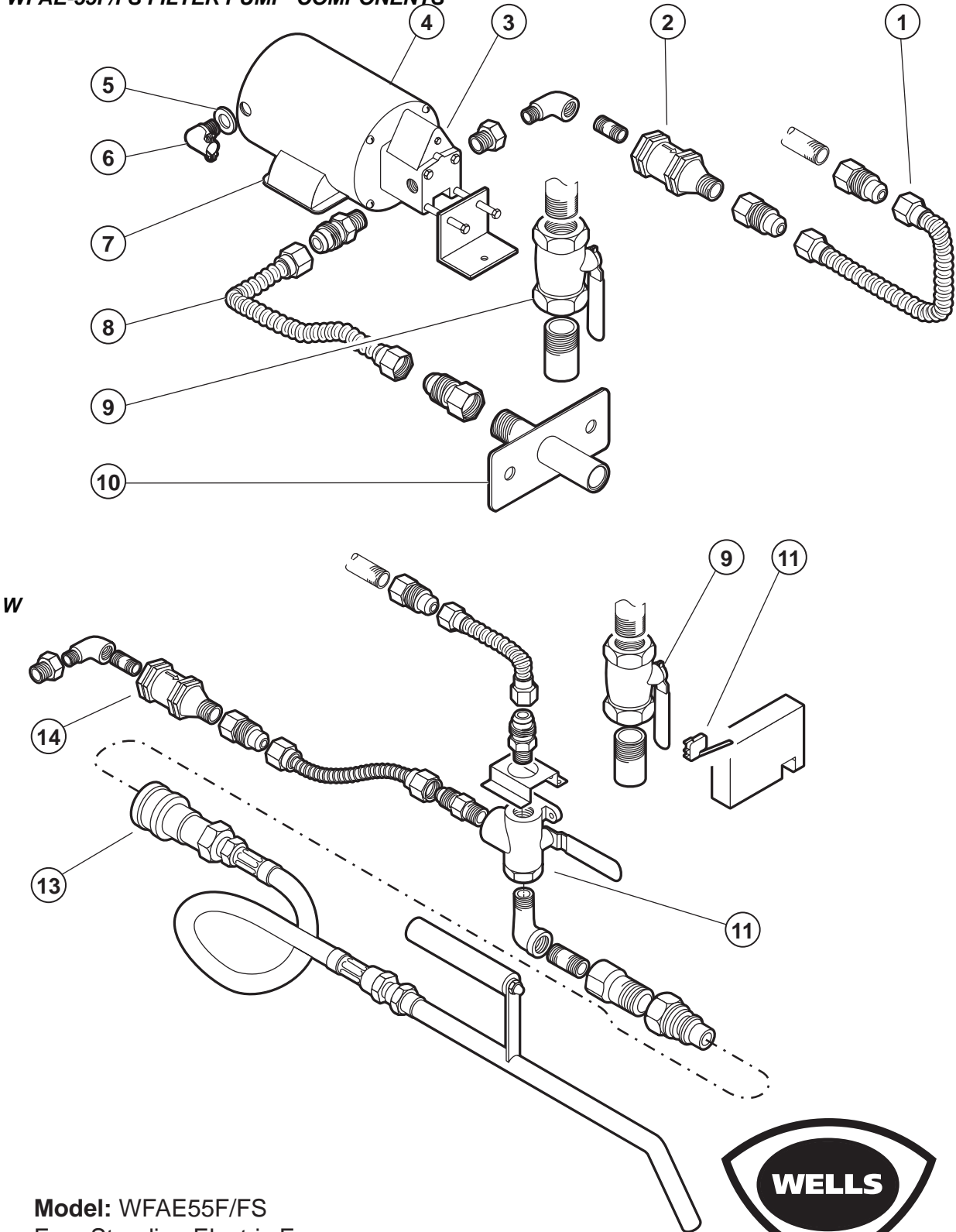

W

Model: WFAE55F/FS
 Free Standing Electric Fryer
 Wand & Filter Pump Components

PL363



IL1767 Rev. B 11/2/09

363 2M-300007 Owners Manual WFAE-55F/FS Free-Standing Electric Fryer

**WFAE-55F/FS ELECTRIC OPEN FRYPOT
WAND & FILTER PUMP COMPONENTS**

Fig No	Part No	Qty	Description
1	2J-302283	1	HOSE ASSY SS .6 OD X 14
2	2V-46692	1	VALVE CHECK 3/8 NPT WF/WVA
3	WS-501231	1	PUMP ASSY
4	WS-501205	1	MOTOR FILTER 1P 115/230V
5	2I-Z12311	1	GASKET-FIBER WASHER
6	2K-3396X	1	FTG FLEX CONDUIT 90X3/8
7	WS-501205	1	MOTOR FILTER 1P 115/230V
8	2J-302287	1	HOSE ASSY SS 3/4 OD X 16
9	2V-49816	1	VALVE BALL 1-1/4 1500PSIG
10	E7-46720	1	SUCTION LINE FTING ASSY
11	2E-44887	1	SWITCH MICRO 120V 15A
12	DD-304309	1	VALVE 3 WAYS SS
13	DD-304734	1	OIL WAND & HOSE ASSY
14	2V-46692	1	VALVE CHECK 3/8NPT WF/WVA

EXPLODED VIEW: WFAE55F/FS

WFAE-55F/FS AUTO-LIFT COMPONENTS

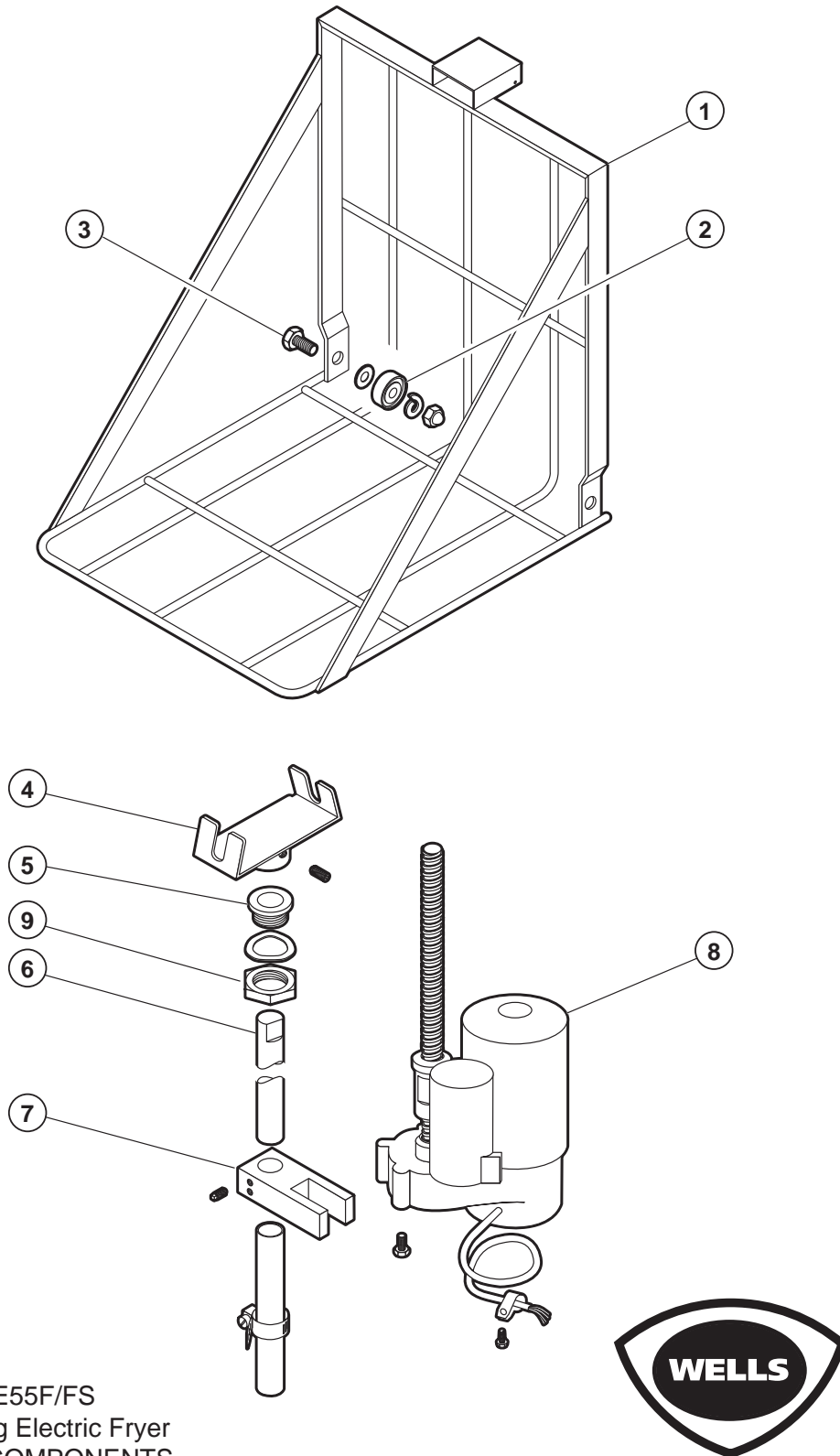

Model: WFAE55F/FS
Free Standing Electric Fryer
AUTO-LIFT COMPONENTS
PL363

IL1769 Rev. B 12/7/09

**WFAE-55F/FS ELECTRIC OPEN FRYPOT
AUTO-LIFT COMPONENTS**

Fig No	Part No	Qty	Description
1	E7-49961	1	CRADLE LIFT BASKET WFAE55
2	2P-300031	2	BEARING ROLLER .750D X .2
3	2C-41048	2	SCREW 1/4-20-3/4
4	DD-300037	1	PIVOT CRADLE WFAE55
5	2K-49972	1	BUSHING LIFT ROD WFAE55
6	2A-300542	1	ROD LIFT MOTOR WFAE55
7	2V-49812	1	YOKE ROD LIFT MOTOR WFAE55
8	2U-300513	1	MOTOR LIFT 1/10HP 230V 50
9	2C-49843	1	NUT 1-14 FINISH HEX JAM

EXPLODED VIEW: WFAE55F/FS

WFAE-55F/FS ACCESSORIES & REMOVABLE COMPONENTS

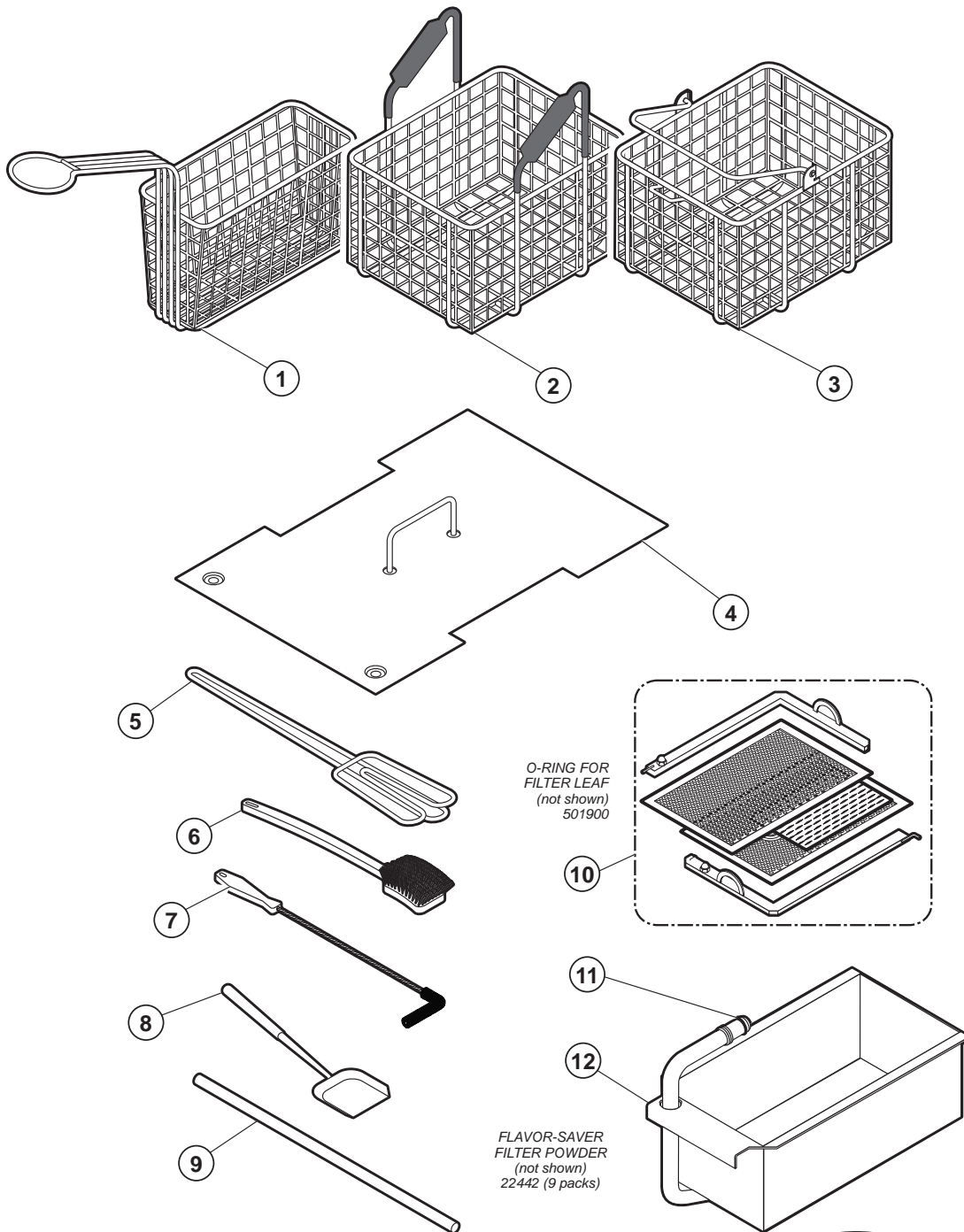

Model: WFAE55F/FS
Free Standing Electric Fryer
ACCESSORIES & REMOVABLE COMPONENTS

PL363



IL1768 Rev. A 5/7/09

363 2M-300007 Owners Manual WFAE-55F/FS Free-Standing Electric Fryer

**WFAE-55F/FS ELECTRIC OPEN FRYPOT
ACCESSORIES & REMOVABLE COMPONENTS**

Fig No	Part No	Qty	Description
1	2B-305097	2	BASKET WIRE TWIN WFAE55
2	2B-301667	1	BASKET FRYER WFA55
3	2B-306245	1	BASKET FRYER WFAE WVAE
4	E7-300235	1	COVER KETTLE WFAE55
5	2B-302203	1	PADDLE STIRRING CHICKEN
6	2P-302204	1	BRUSH CLEANING FRYERS
7	2P-46479	1	BRUSH CLEANING ELEMENT
8	2R-301901	1	SHOVEL STAINLESS STEEL
9	2C-49752	1	DOWEL CLEANOUT DRAIN
10	2I-301847	1	FILTER LEAF
11	2I-46474	5	O-RING .5 ID X .63 OD VIT
12	E7-301845	1	RESERVOIR ASSY WFAE55
NI	WS-501900	1	O-RING FILTER LEAF
NI	2M-301698	1	POWDER FILTER 9 PACK WFAE

WIRING DIAGRAM

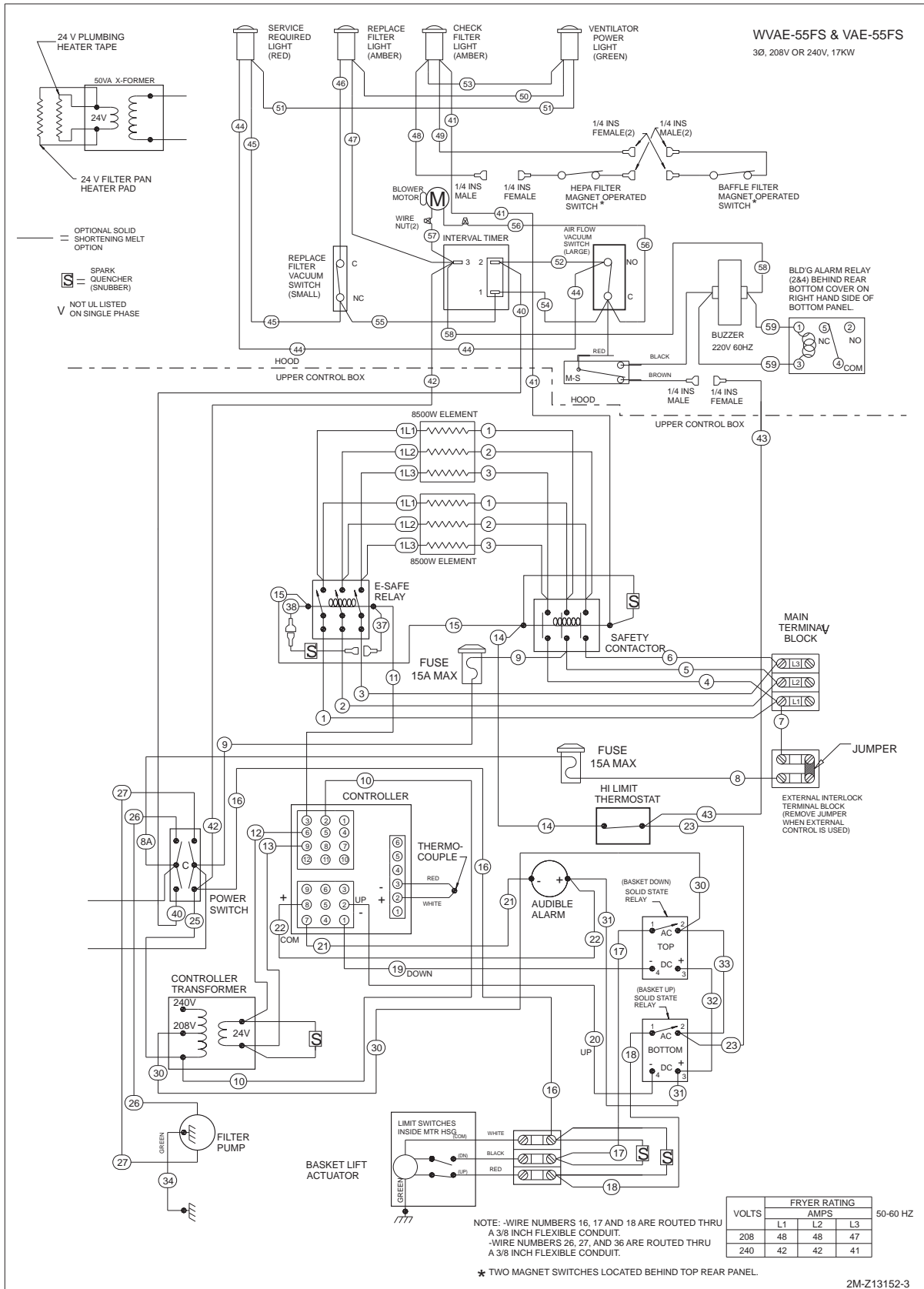

363 2M-300007 Owners Manual WVAE-55FS/VAE-55FS Free-Standing Electric Fryer

WIRING DIAGRAM

WVAE-55F & VAE-55F
30, 208V OR 240V, 17KW

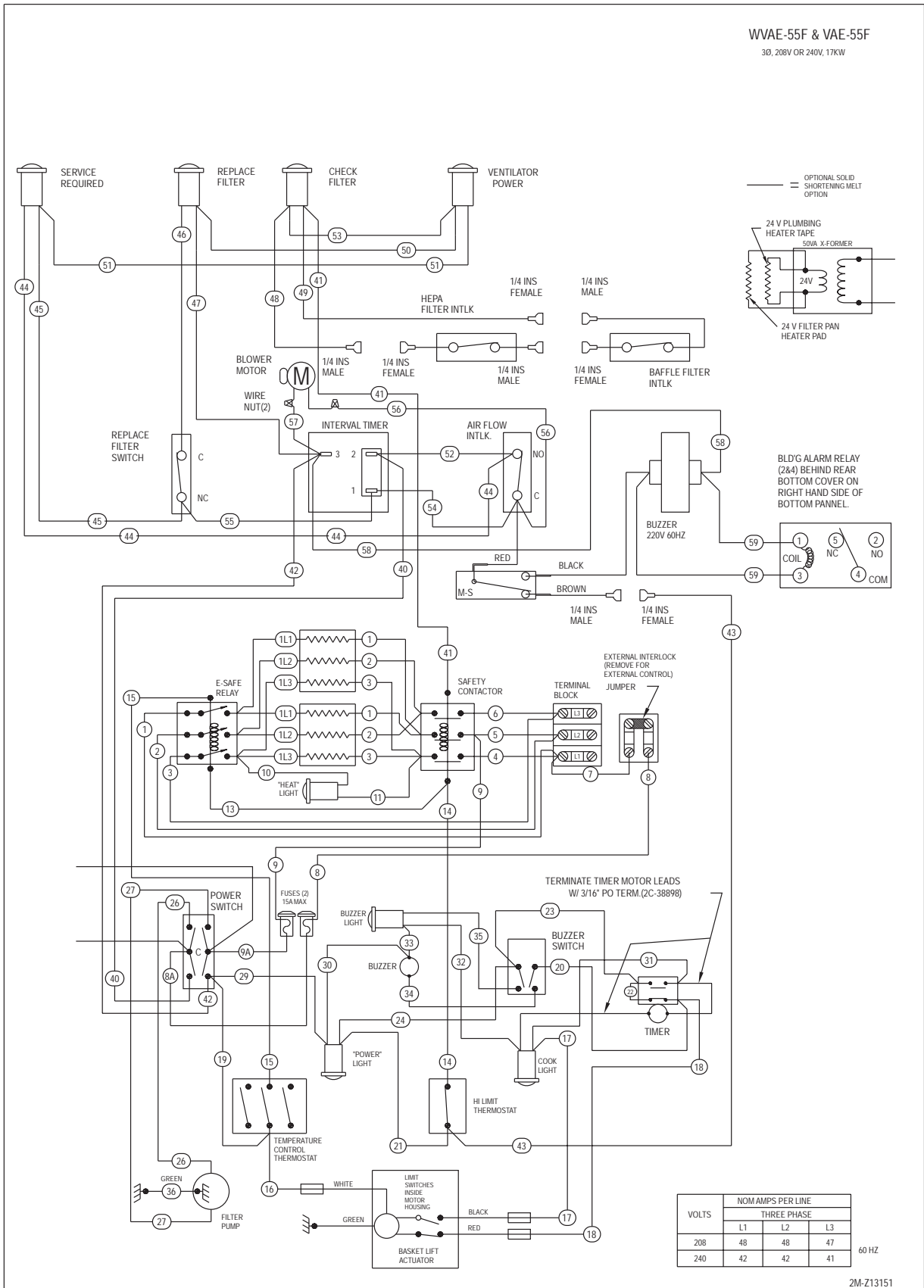

VOLTS	NOM AMPS PER LINE		
	L1	L2	L3
208	48	48	47
240	42	42	41

60 HZ

2M-Z13151

PARTS & SERVICE

DESCRIPTION

PART NO.

BRUSH, CLEANING HEATING ELEMENT	2P-46479
FLAVOR-SAVER OIL FILTER POWDER (pk45)	WS-22410
WAOC-1 MOBILE OIL DISPOSAL CADDY	5E-WAOC1
PADDLE, STIRRING CHICKEN	2B-302203
BRUSH, CLEANING FRYPOT	2B-302204
*FILTER WAND ASSY	DD-304734

IMPORTANT: Use only factory authorized service parts and replacement filters.

For factory authorized service, or to order factory authorized replacement parts, contact your Wells authorized service agency, or call:

MOLYDISULFIDE LUBE

(LOCAL PURCHASE)

***NOTE:** The filter wand assembly involves a different plumbing arrangement than standard fryer. This option must be ordered at time of initial build and cannot be economically retrofitted to existing fryers.

Wells Bloomfield, LLC

10 Sunnen Dr.,
St. Louis MO 63143 USA

Service Dept.

phone: (314) 678-6314
fax: (314) 781-2714

Service Parts Department can supply you with the name and telephone number of the WELLS AUTHORIZED SERVICE AGENCY nearest you.

CUSTOMER SERVICE DATA

please have this information available if calling for service

RESTAURANT _____ LOCATION _____
INSTALLATION DATE _____ TECHNICIAN _____
SERVICE COMPANY _____
ADDRESS _____ STATE _____ ZIP _____
TELEPHONE NUMBER (____) _____ - _____

EQUIPMENT MODEL NO. _____
EQUIPMENT SERIAL NO. _____

FUEL (check one) 08VAC 10VAC 38 415 3NAC



Wells Bloomfield proudly supports CFESA
Commercial Food Equipment Service Association

SERVICE TRAINING - QUALITY SERVICE



CUSTOMER SATISFACTION

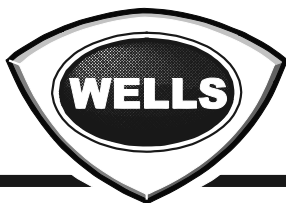

WELLS BLOOMFIELD, LLC
10 Sunnen Dr., St. Louis, MO 63143
telephone: 314-678-6314
fax: 314-781-2714
www.wellsbloomfield.com