

EXPLODED VIEW PARTS LIST

CABINET AND HOOD SECTION COMPONENTS

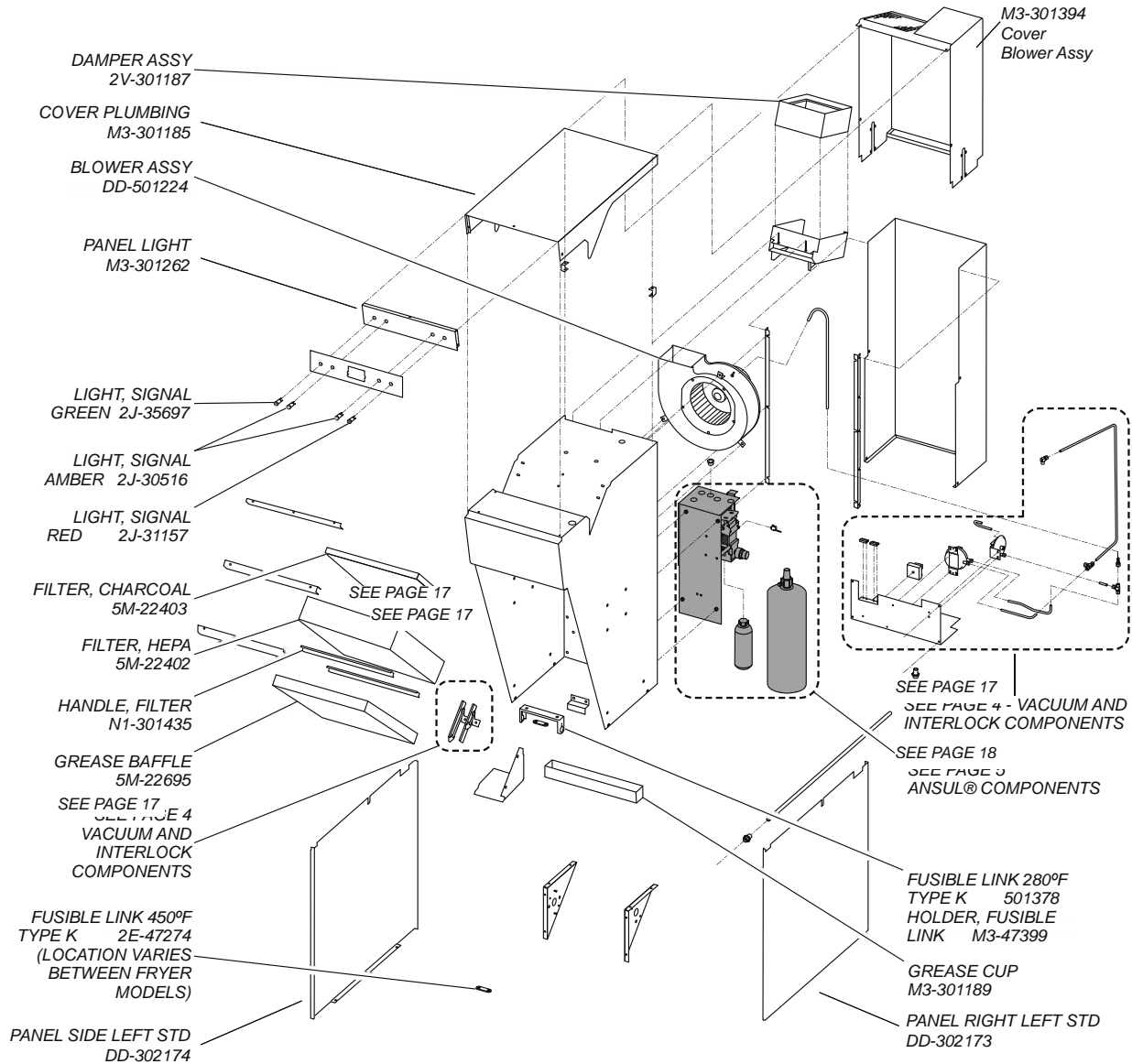

IL2114B

EXPLODED VIEW PARTS LIST

VACUUM AND INTERLOCK SYSTEM COMPONENTS

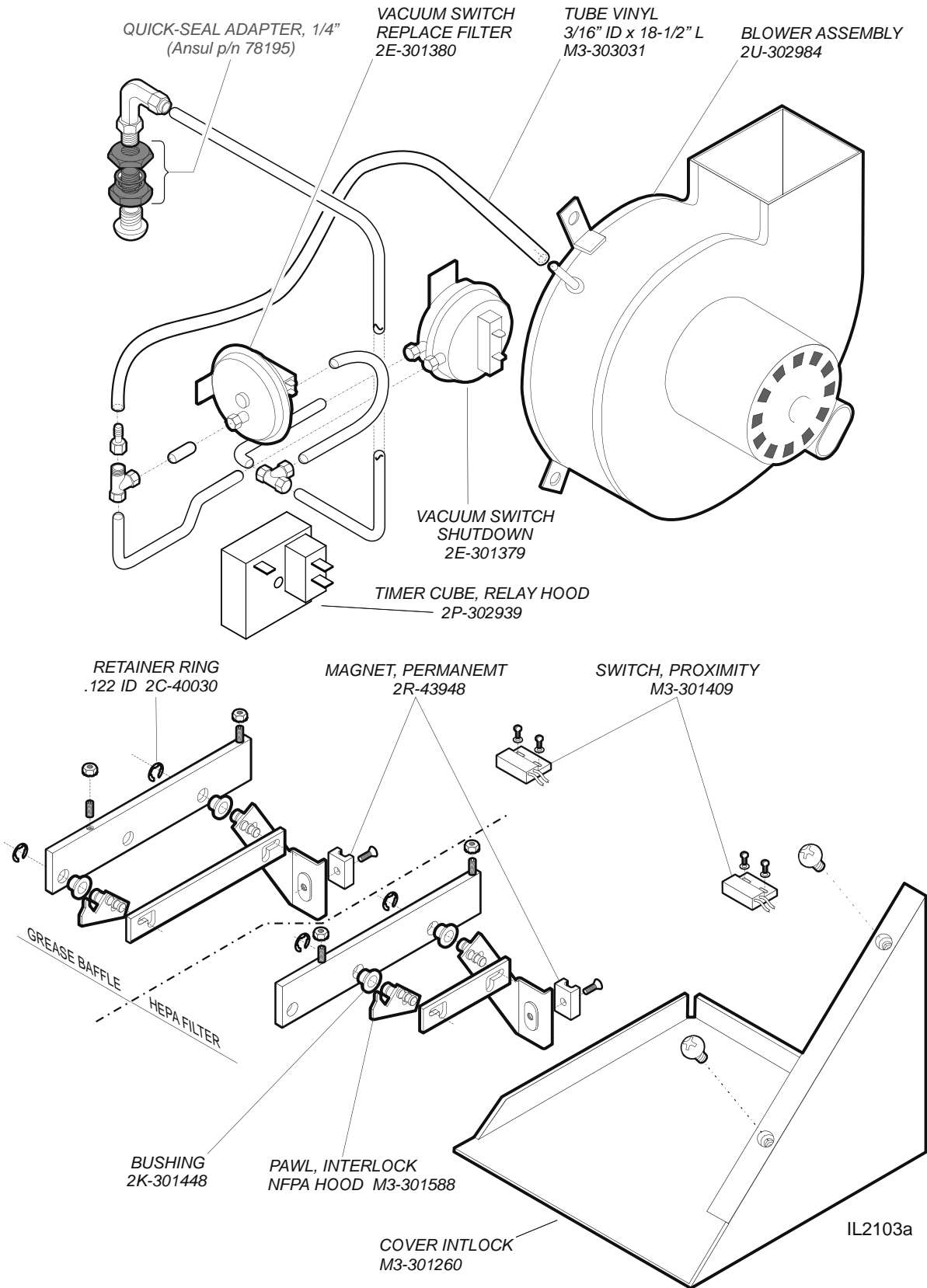

EXPLODED VIEW PARTS LIST

FIRE DETECTION AND SUPPRESSION SYSTEM COMPONENTS

**FOR USE ONLY BY AUTHORIZED
ANSUL® SERVICE PERSONNEL**

Refer to Ansul® part no. 418078-05
R-102 Restaurant Fire Suppression
System Design, Installation,
Recharge and Maintenance

