

# PARTS BREAKDOWN for ANSUL® COMPONENTS

**FOR USE ONLY BY AUTHORIZED ANSUL® SERVICE PERSONNEL**

Refer to Ansul® part no. 418078-05 R-102 Restaurant Fire Suppression System Design, Installation, Recharge and Maintenance

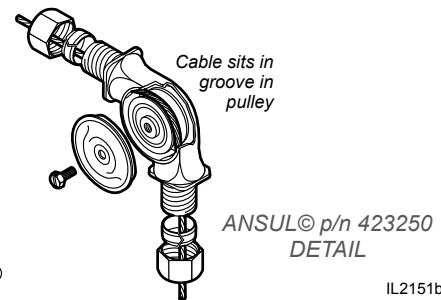
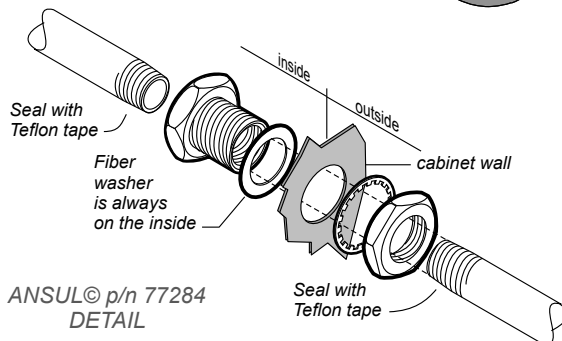
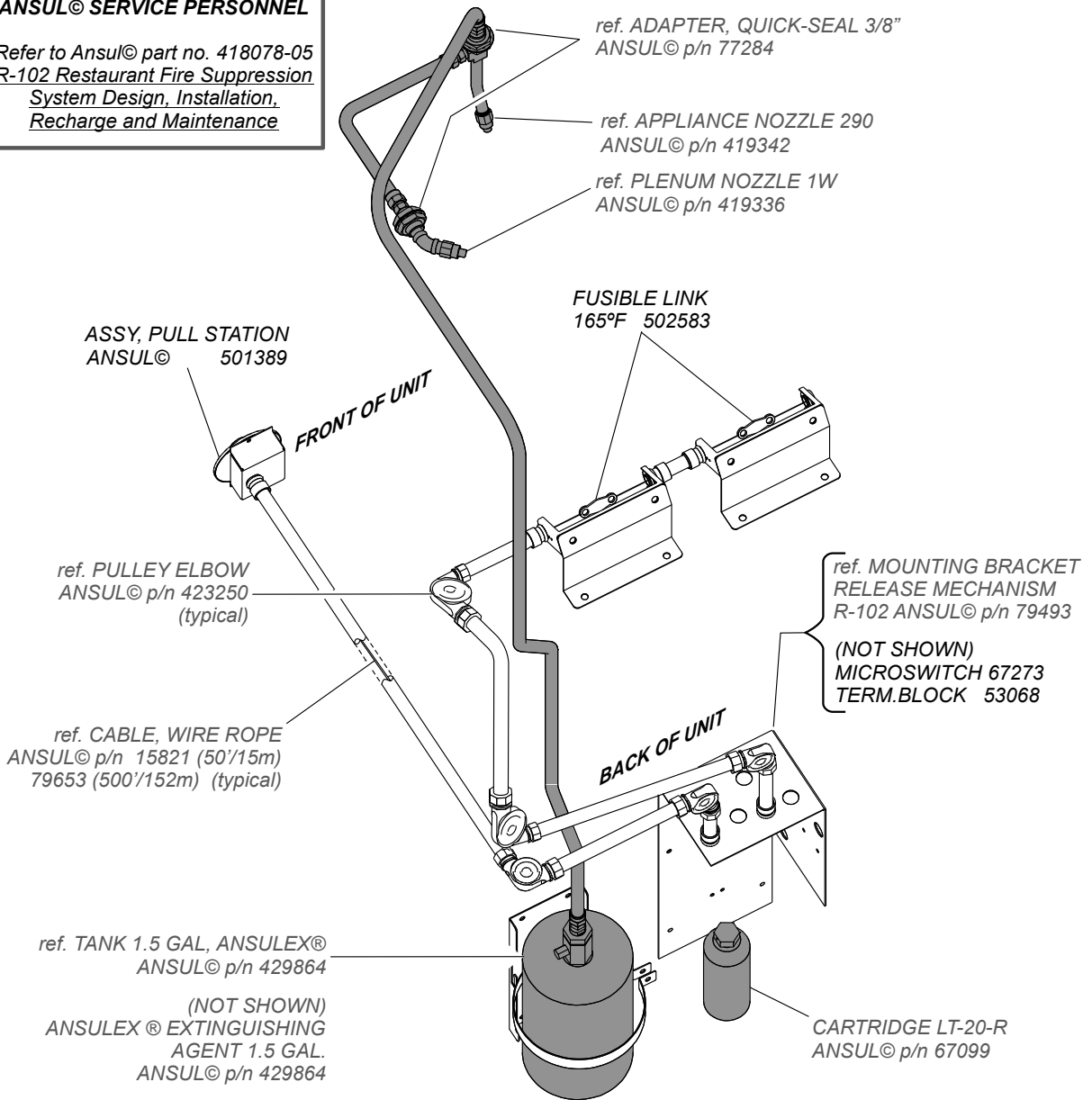

503 p/n 2M-304989 Owners Manual WVF-886 Ventless Fryer

IL2151b

# EXPLODED VIEW & PARTS LIST

## HOOD CABINET COMPONENTS

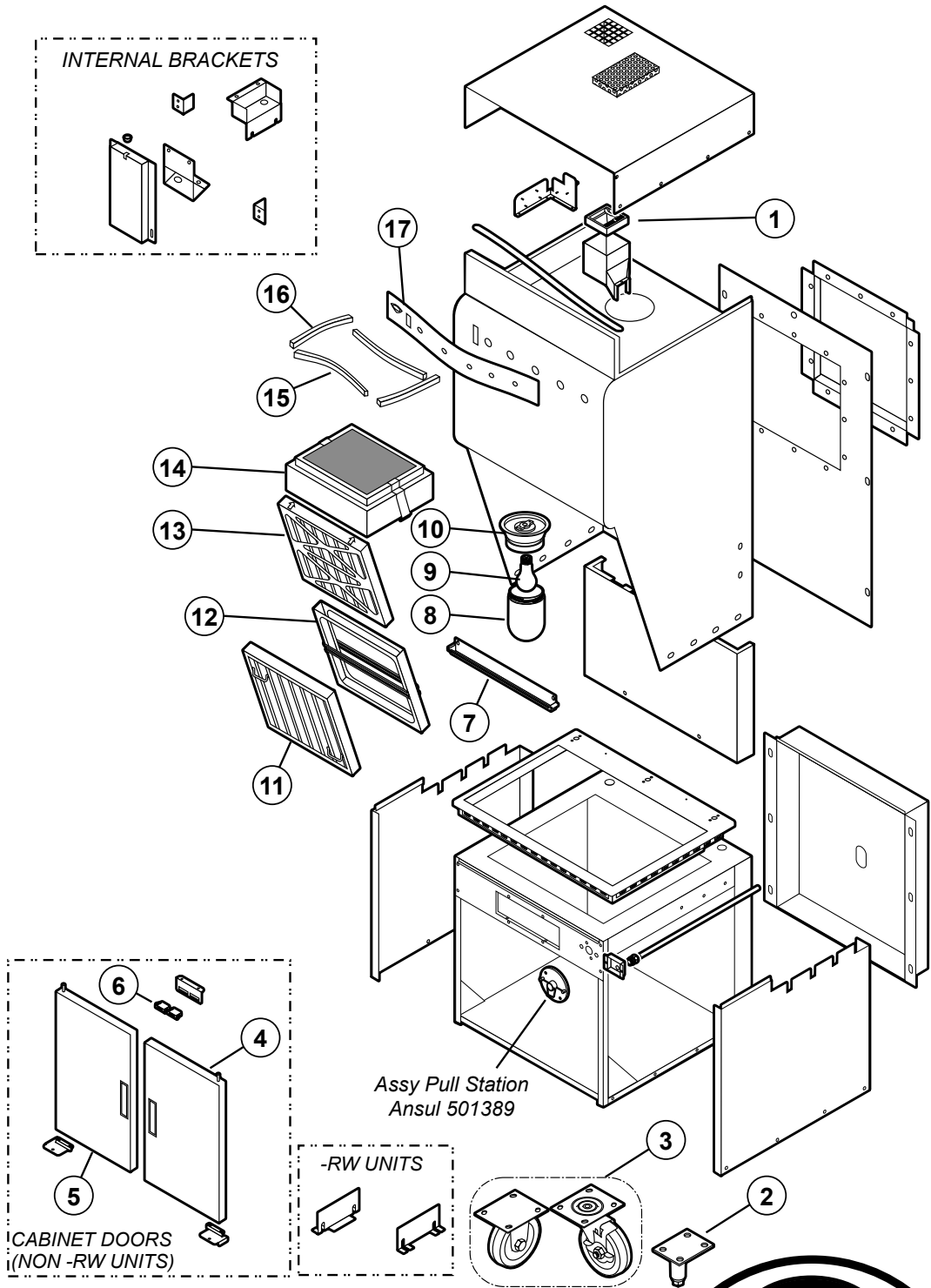

**Model:** WVF886 Hood Cabinet Components  
 Dual Frypot Auto-Lift Fryer with Universal Hood  
 PL503

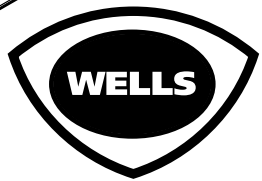

IL1740 Rev. - 4/20/09

## EXPLODED VIEW & PARTS LIST

<b>WVF886 Hood Cabinet Components</b>			
<b>Fig No</b>	<b>Part No</b>	<b>Qty</b>	<b>Description</b>
1	2V-301187	1	Damper
2	WS-22648	Set of 2	KIT LEG REAR OPT WVF/WVG
3	5E-20804	1 Set	CASTER ASSY 2FIX 2SWVL
4	M3-302646	1	DOOR ASSY RIGHT
5	M3-302642	1	DOOR ASSY LEFT
6	2R-46502	2	MAGNET DOOR
7	M3-304405	1	TRAY GREASE DRIP HOOD
8	2Q-305099	1	GLASS GLOBE VCS HOOD
9	2S-305100	1	LIGHT BULB 100W VCS HOOD
10	2E-305098	1	LIGHT HOUSING VCS HOOD
11	2I-302580	1	FILTER BAFFEL
12	M3-302688	1	PREFILTER CAGE
13	2I-302579	1	FILTER PRE HOOD UNIVERSAL
14	WS-22619	1	FILTERPACK ASSY UNIV HOOD
15	WS-502773	2	GASKET SILICONE .25X5X18
16	WS-502772	2	GASKET SILICONE .25X5X15
17	2M-302782	1	FACEPLATE FRNT PNL UNIV

# EXPLODED VIEW & PARTS LIST

## HOOD ELECTRICAL & VACUUM COMPONENTS

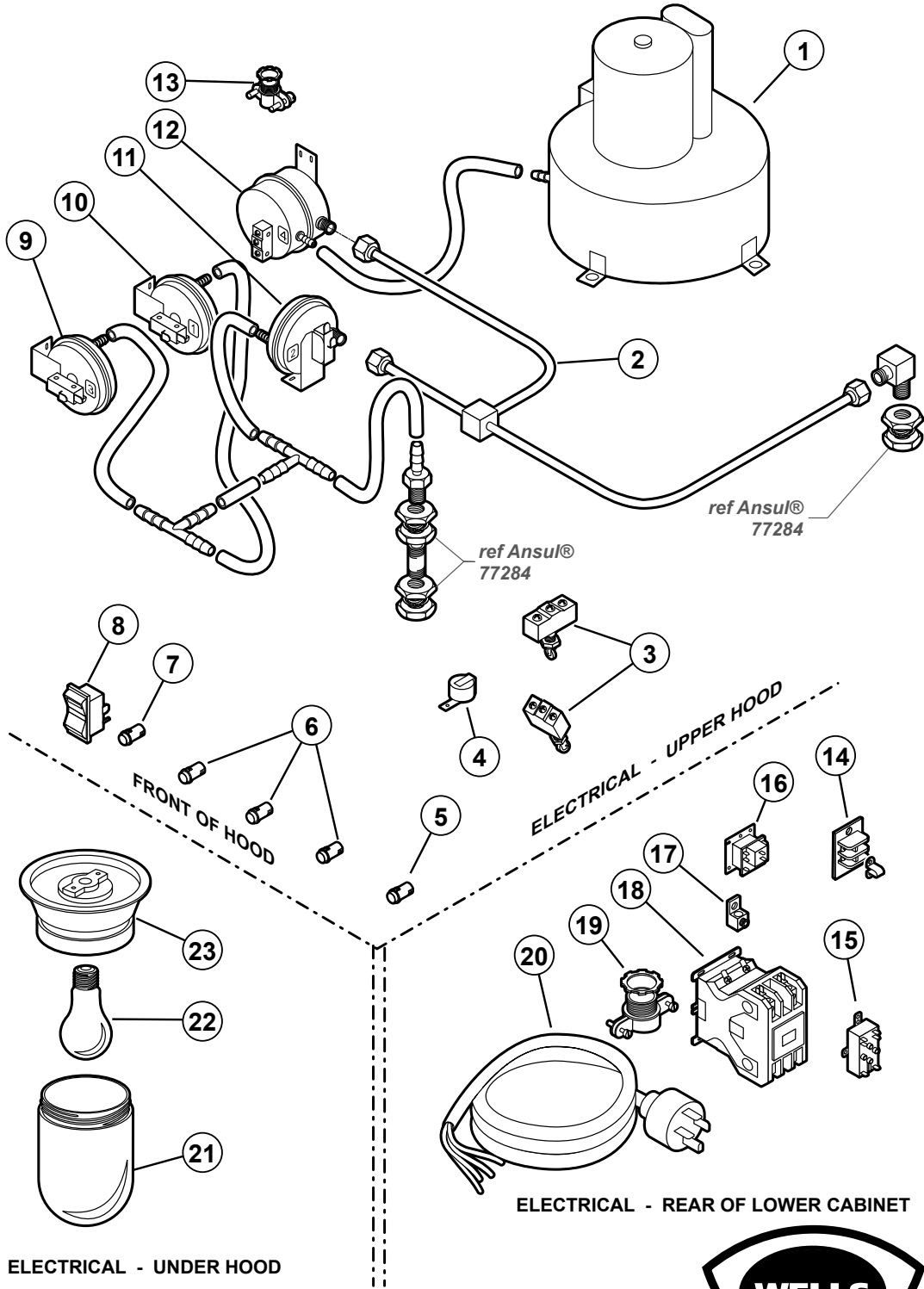

**Model:** WVF886 Hood Electrical & Vacuum Components  
 Dual Frypot Auto-Lift Fryer with Universal Hood

PL503

IL1742 Rev. A 2/14/12



503 p/n 2M-304989 Owners Manual WVF-886 Ventless Fryer

## EXPLODED VIEW & PARTS LIST

WVF886 Hood Electrical & Vacuum Components				
Fig No	Part No	Qty	Description	Application
1	2U-302584	1	BLOWER ASSY UNIVERSAL HD	
2	WS-502588	1	TUBING ASSY VACUUM UNIV	
3	2E-300407	2	SWITCH MANUAL ADVANCE ROT	
4	2J-44834	1	BUZZER 220V ROHS	
5	2J-31157	1	LIGHT SIGNAL RED	
6	2J-30516	3	LIGHT SIGNAL AMBER	
7	2J-35697	1	LIGHT PILOT GREEN 250V	
8	2E-70395	1	SWITCH ROCKER 240V 20A	
9	2E-302592	1	SWITCH VACUUM #3	
10	2E-302590	1	SWITCH VACUUM #1	
11	2E-302591	1	SWITCH VACUUM #2	
12	2E-302593	1	SWITCH VACUUM #4	
13	2K-37748X	1	FTG CONDUIT STRAIGHT 3/8	
14	2E-34005	1	JUMPER FLAME SENSOR TERM	
15	2E-44514	1	RELAY 208-240 COIL	
16	2E-43880	1	RELAY 208/240 DPDT (RW & RWT ONLY)	
17	2C-307288	1	LUG GROUND SOLDERLESS	
18	2E-Z15704	1	CONTACTOR 75A 3POLE	
19	2K-304420	1	STRAIN RELIEF 1 1/4NPT	3 Phase
20	M3-303130	1	CORD SET 60AMP 3 PHASE W/PLUG	3 Phase
21	2Q-305099	1	GLASS GLOBE WCS HOOD	
22	2S-305100	1	LIGHT BULB 100W VCS HOOD	
23	2E-305098	1	LIGHT HOUSING VCS HOOD	

# EXPLODED VIEW & PARTS LIST

## DRAWER WARMER COMPONENTS

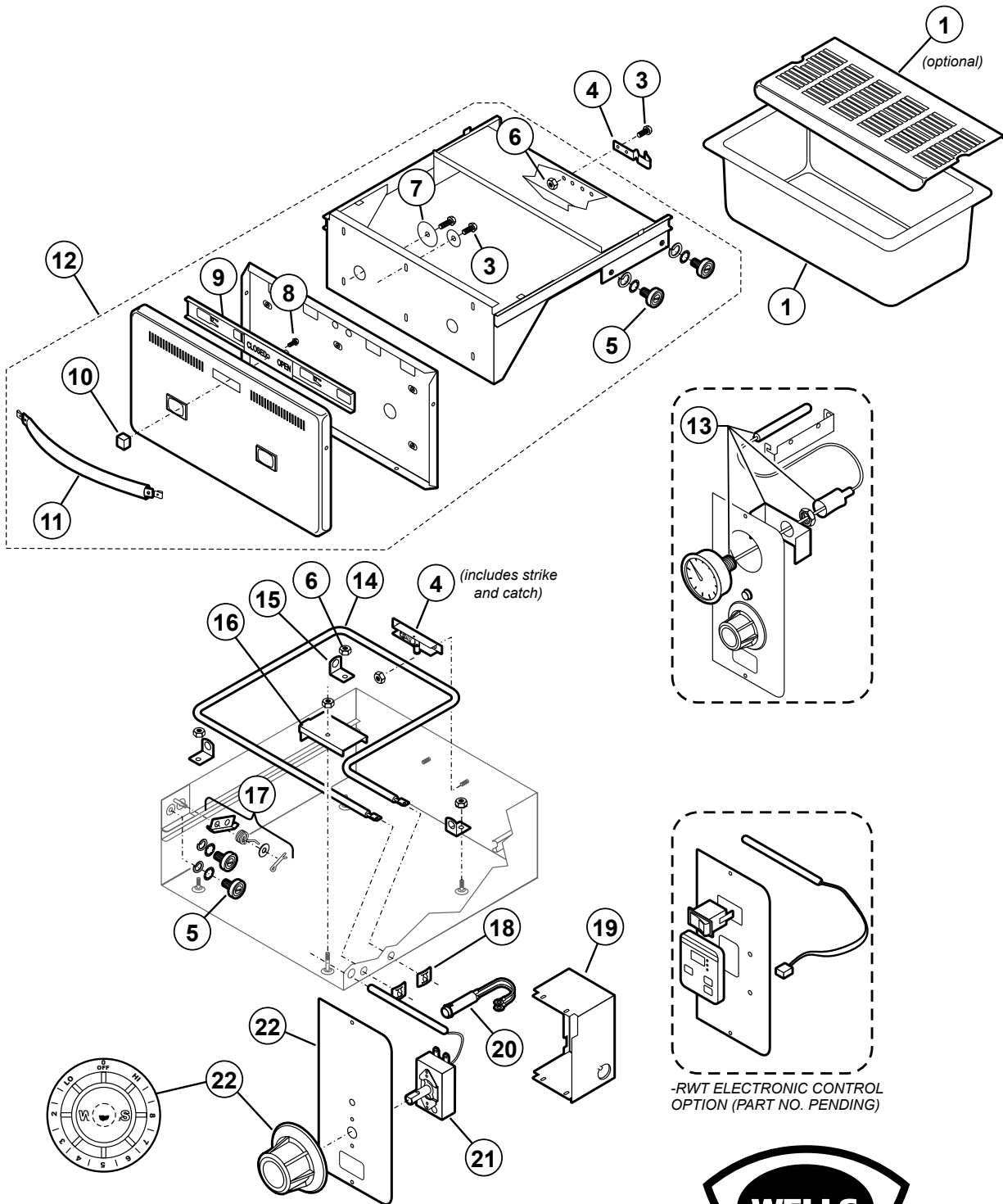

**Model:** WVF886 Drawer Warmer Components  
Dual Frypot Auto-Lift Fryer with Universal Hood

PL503



IL1743 Rev. - 4/20/09

## EXPLODED VIEW & PARTS LIST

WVF886 Drawer Warmer Components			
Fig No	Part No	Qty	Description
1	WS-20624	OPTIONAL	RACK HUMITROL RWS
2	C8-46840	2	PAN INSERT DRAWER RWHD
3	WS-55487	(pk 50)	SCREW 8-32X5/16 PH (PACK OF 50)
4	2C-30471	2	CATCH IVEES MACH AS RECD
5	WS-50483	(pk 6)	BEARING ROLL WARMER SET OF 6
6	2C-35455	AR	NUT 8-32 HEX MS SS
7	2C-35565	AR	WASHER 2 1/16 DRWR BACK RWS
8	2C-35530	AR	SCREW 8-32X3/8PH RD
9	C8-49251	2	SLIDE VENT ASSY RWN
10	WS-51796	2	KNOB SQUARE ROLL WARMER VENT
11	WS-52112	2	HANDLE R W DRAWER
12	WS-67096	2	DRAWER ASY KIT RWHD
13	2T-44475	OPTIONAL	THERMOMETER RW 2 IN DIAL
14	2N-30482UL	2	ELEM 240V 450W
	2N-30519UL		ELEM 120V 450W
15	C8-35677	2	BRKT ELEM MTG RW
17	WS-65923	AR	KIT REPAIR DWR STOP 6-COIL SPR
18	WS-63271	(PK 10)	CLIP RETAINER PILOT LIGHT
19	C8-307569	2	BOX OUTLET
20	2J-35687	2	LIGHT SIGNAL RED RWS
21	2T-38936	2	THERM CONT RW W/O AUX SW
22	C8-31801	1	PANEL CONTROL RW TW324
	C8-33565		PANEL CONTROL LOWER RWS
23	2R-30372	2	KNOB CONTROL ASSY WARM

# EXPLODED VIEW & PARTS LIST

## FRYER AUTOLIFT COMPONENTS

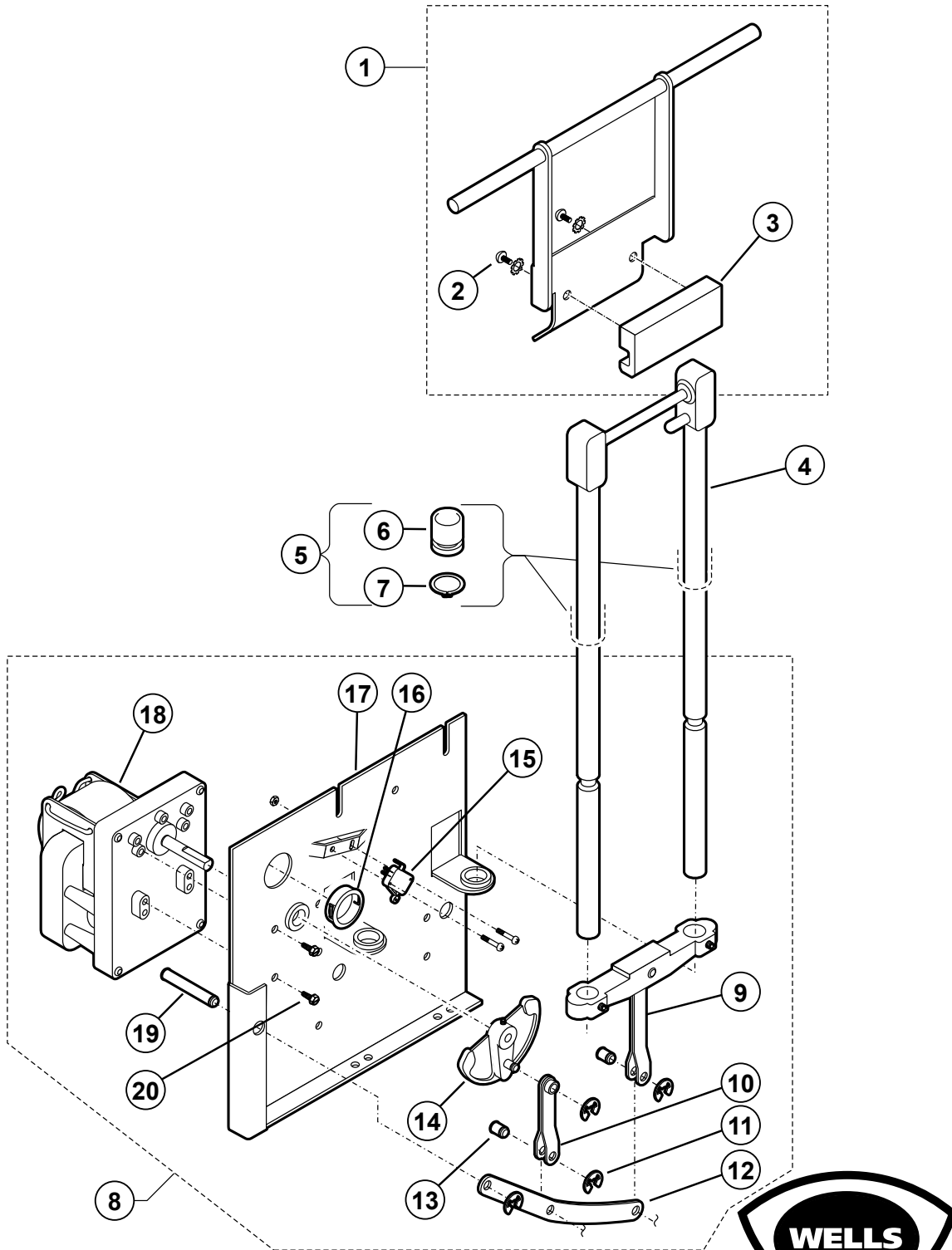

**Model:** Fryer Auto-Lift Components  
Dual Frypot Auto-Lift Fryer with Universal Hood

PL503

IL1744 Rev. - 4/21/09

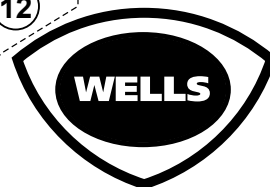



## EXPLODED VIEW & PARTS LIST

WVF886 Fryer Auto-Lift Components			
Fig No	Part No	Qty	Description
1	WS-505656	2	BRKT LIFT ASSY F-585F
2	2C-35487	AR	SCREW 8-32X5/16 PH
3	2V-305658	2	BLOCK PIVOT SS F-58SF
4	2A-31146	2	ROD LIFT BSKT
5	WS-50231	2	BASKET LIFT ROD SEAL-PTFE
6	2I-30231	2	SEAL OIL PTFE LARGE
7	2I-31145	AR	RETAINER OIL SEAL
8	WS-50850	2	MOTOT LIFT ASSY
9	E7-30543	2	ARM CROSS ASSY
10	E7-30878	2	ARM CRANK LEVER ASSY
11	2C-30222	8	RETAINER RING
12	2D-30215	2	ARM ROCKER
13	2A-30876	4	PIN, LEVER MOTOR ASSY
14	2A-30207	4	CRANK CASTING SHORT
15	2E-30198	2	SWITCH UNIMAX
16	2K-31040	2	BUSHING HEYCO 7/8 OD
17	E7-31259	2	BRKT AUTOLIFT ROHS
18	2U-30233	2	MOTOR LIFT ELECT FRYERS
19	2A-30205	2	PIN PIVOT
20	2C-35530	AR	SCREW, 8-32X3/8 RD

# EXPLODED VIEW & PARTS LIST

## FRYER FRYHEAD COMPONENTS

*NOTE: Fryer has two identical fryer heads. Only one is shown.*

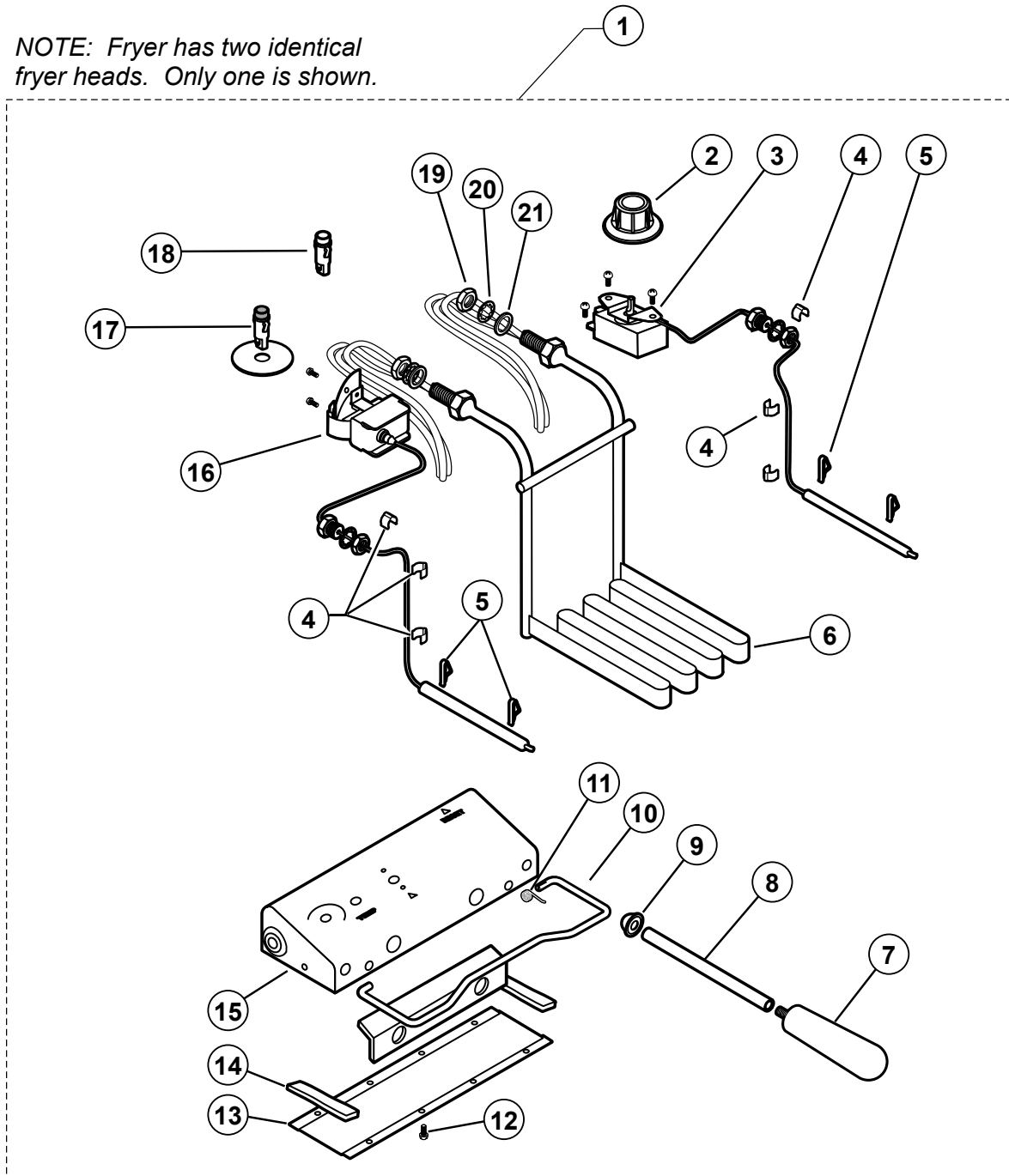

**Model:** F886 Complete Head Assembly  
Dual Frypot Auto-Lift Fryer with Universal Hood

PL503



IL1745 Rev. - 4/21/09

503 p/n 2M-304989 Owners Manual WWF-886 Ventless Fryer

## EXPLODED VIEW & PARTS LIST

### WVF886 Fryer Head Components

Fig No	Part No	Qty	Description
1	WS-62926	2	HEAD ASSEMBLY F88-6 208V STS
	WS-62927		HEAD ASSEMBLY F88-6 240V STS
2	2R-37882	2	KNOB CONTRL ASSY AUTOFRY
3	WS-55510	2	THERMO CTRL FRYER KP-715
4	2C-30157	AR	CLIP CAPILLARY
5	WS-62504	(4 PK)	CLAMP BULB SAFTEY PK OF 4
6	2N-42842UL	2	ELEM 208V 5750W
	2N-42866UL		ELEM 240V 5750W
7	2R-30211	2	HANDLE LIFT GRAY
8	2K-33358	2	ADAPTER HANDLE F58, 68, 88
9	2P-34452	2	CAP PUSH ON TYPE BASKET
10	2A-32427	2	ROD SUPPORT SHORT HEAD
11	2P-32428	2	SPRING SUPPORT ROD
12	WS-55566	(100 PK)	SCREWS(SERV)6X1/4 TH SS
13	E7-35028	2	COVER CONTROL BOX WO/SAF
14	2I-55747	4	GASKET DRWR RWS CLOSED CE
15	E7-30464	2	BOX CONTROL ASSY F5585
16	WS-58656	2	THERMO HI-LIMIT MAIN RESET
17	2J-31157	2	LIGHT SIGNAL RED
18	2J-30516	2	LIGHT SIGNAL AMBER 240V
19	2C-30172	4	NUT 7/8-14 HEX
20	WS-50176	(10 PK)	WASHER LOCK 7/8 FRYER ELEM PK10
21	2I-Z12311	4	GASKET -FIBER WASHER

# EXPLODED VIEW & PARTS LIST

## FRYER CABINET COMPONENTS

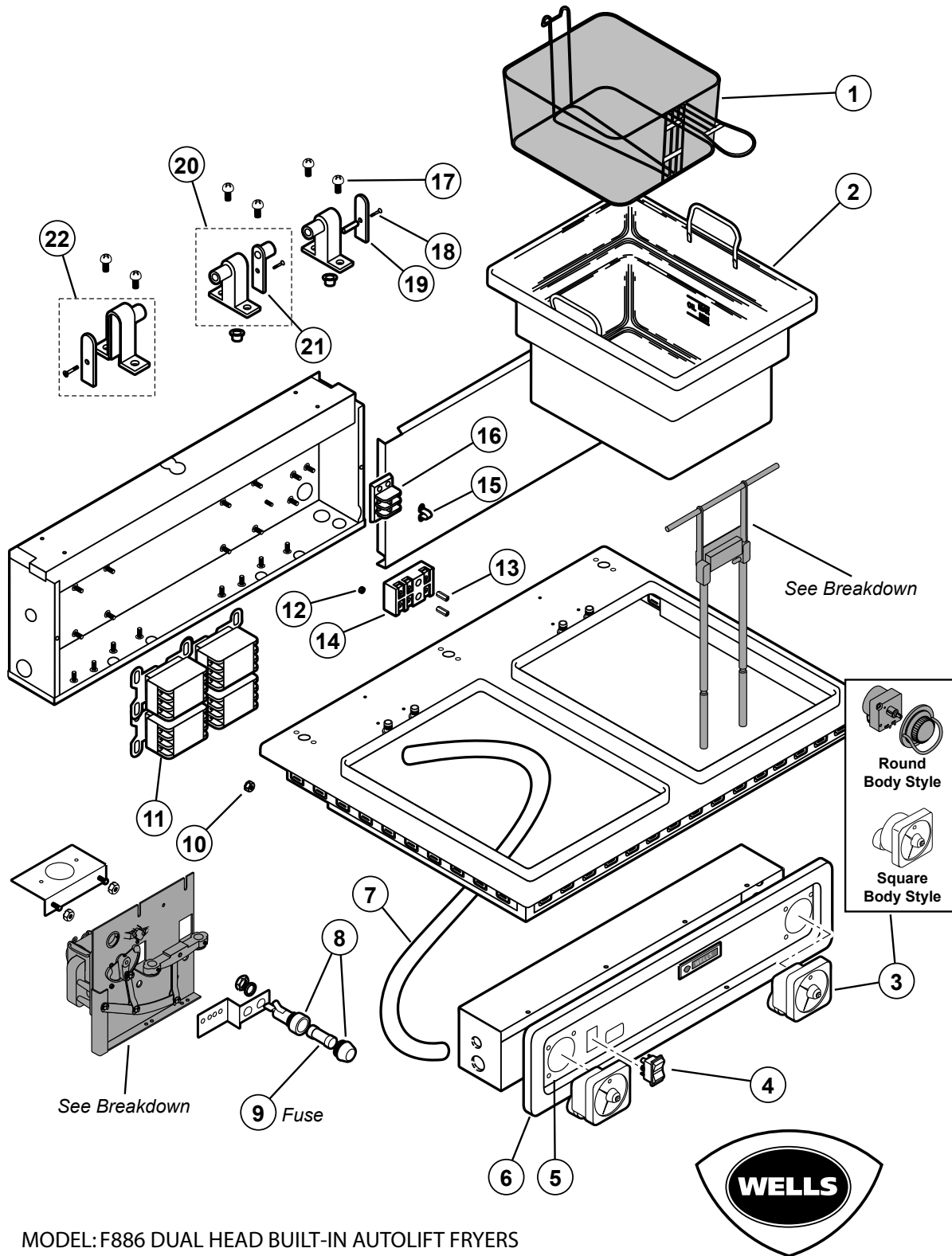

MODEL: F886 DUAL HEAD BUILT-IN AUTOLIFT FRYERS

Wells / Bloomfield LLC.  
IL1725 Rev. B 10/12/11

## EXPLODED VIEW & PARTS LIST

WVF886 Fryer Cabinet Components				
Fig No	Part No	Qty	Description	Application
1	2B-43688	AR	BASKET 1/2 SIZE	
	2B-43689		BASKET FULL SIZE	
2	E7-301344	2	POT ASSY F SERIES FRYER	
3	PS-WL0153	1	KIT, TIMER 40MIN 240V DPST (BUILT FROM 11/01)	Round Body Style
	PS-WL0148	2		
	PS-WL0152	1		Square Body Style
	PS-WL0151	2		
4	2E-35127	1	SWITCH ROCK PLAS BEZEL	
5	2M-308072	1	FACEPLATE VCS F886 STS	
6	E7-308069	1	CONTROL PANEL VCS F886	
7	WS-51881	3 FT	SLEEIVING VARGLAS 3' LONG	
8	2E-34769	1	FUSEHLDR HPG-EE 10A 240V	
9	2E-34768	1	FUSE SC-10, 10A 300V	
10	2C-31053	AR	NUT 8-32 KEPS MS NICKEL	
11	WS-57779	4	CONTACTOR 3POLE 208V 40A	
11	WS-57780	4	CONTACTOR 3POLE 240V 40A	
12	2C-35736	AR	NUT 8-32 HEX KEPS MS	
13	2C-41974	AR	NUT 8-32 HEX 7/8 LONG ALU	
14	WS-50131	1	TERM BLOCK KIT	
15	2E-34005	1	JUMPER FLAME SENSOR TERM	
16	WS-53068	1	TERM BLOCK 2 POLE	
17	2C-33890	AR	SCREW 12-24X3/4PH PAN	
18	2C-31717	AR	SCREW 8X32X7/8 PH FL ROLO	
19	2A-32806	2	COVER PIVOT BRKT TUMBLED	
20	WS-53895	1	CENTER PIVOT BRKT ASSY	
21	H6-33245	1	COVER PIVOT DBL TUMBLE	
22	WS-50183	2	HINGE BRACKET END	