

WELLS BLOOMFIELD, LLC

10 Sunnen Drive P.O.Box 430195
St. Louis, MO 63143 USA
telephone: 314-781-2777
fax: 314-781-2714
www.wellsbloomfield.com

531

OWNERS MANUAL

**MODEL
WVSW
VENTLESS
HOOD**
For
**CONVEYOR
WARMERS**



**Includes
INSTALLATION
USE & CARE
SERVICE
EXPLODED VIEW
PARTS LIST
WIRING DIAGRAM**

IMPORTANT: DO NOT DISCARD THIS MANUAL

This manual is considered to be part of the appliance and is to be given to the OWNER or MANAGER of the restaurant, or to the person responsible for TRAINING OPERATORS of this appliance. Additional manuals are available from your WELLS DEALER.

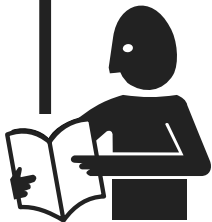

THIS MANUAL MUST BE READ AND UNDERSTOOD BY ALL PERSONS USING OR INSTALLING THIS APPLIANCE. Contact your WELLS DEALER if you have any questions concerning installation, operation or maintenance of this equipment.

PRINTED IN UNITED STATES OF AMERICA

LIMITED WARRANTY STATEMENT

Unless otherwise specified, all commercial cooking equipment manufactured by WELLS BLOOMFIELD, LLC is warranted against defects in materials and workmanship for a period of one year from the date of original installation or 18 months from the date of shipment from our factory, whichever comes first, and is for the benefit of the original purchaser only.

THIS WARRANTY IS THE COMPLETE AND ONLY WARRANTY, EXPRESSED OR IMPLIED IN LAW OR IN FACT, INCLUDING BUT NOT LIMITED TO, WARRANTIES OF MERCHANTABILITY OR FITNESS FOR ANY PARTICULAR PURPOSE, AND/OR FOR DIRECT, INDIRECT OR CONSEQUENTIAL DAMAGES IN CONNECTION WITH WELLS BLOOMFIELD PRODUCTS. This warranty is void if it is determined that, upon inspection by an authorized service agency, the equipment has been modified, misused, misapplied, improperly installed, or damaged in transit or by fire, flood or act of God. It also does not apply if the serial nameplate has been removed, or if service is performed by unauthorized personnel. The prices charged by Wells Bloomfield for its products are

based upon the limitations in this warranty. Seller's obligation under this warranty is limited to the repair of defects without charge by a Wells Bloomfield factory authorized service agency or one of its sub-service agencies. This service will be provided on customer's premises for non-portable models. Portable models (a device with a cord and plug) must be taken or shipped to the closest authorized service agency, transportation charges prepaid, for service. In addition to restrictions contained in this warranty, specific limitations are shown in the Service Policy and Procedure Guide. Wells Bloomfield authorized service agencies are located in principal cities. This warranty is valid in the United States and Canada and void elsewhere. Please consult your classified telephone directory, your foodservice equipment dealer or contact:

Wells Bloomfield, LLC
10 Sunnen Dr., P.O.Box 430129 St. Louis MO 63143 USA
phone (314) 781-2777 or fax (314) 781-2714

for information and other details concerning warranty.

SERVICE POLICY AND PROCEDURE GUIDE and ADDITIONAL WARRANTY EXCLUSIONS

1. Resetting of safety thermostats, circuit breakers, over load protectors, and/or fuse replacements are **not** covered by this warranty unless warranted conditions are the cause.
2. All problems due to operation at **voltages or phase other than specified on equipment nameplates** are **not** covered by this warranty. Conversion to correct voltage and/or phase must be the customer's responsibility.
3. All problems due to **electrical connections not made in accordance with electrical code requirements and wiring diagrams** supplied with the equipment are **not** covered by this warranty.
4. Replacement of items **subject to normal wear**, to include such items as knobs, light bulbs; and, normal maintenance functions including adjustments of thermostats, adjustment of micro switches and replacement of fuses and indicating lights are **not** covered by warranty.
5. Damage to electrical cords and/or plug due to exposure to excessive heat are **not** covered by this warranty.
6. Full use, care, and maintenance instructions supplied with each machine. Noted maintenance and preventative maintenance items, such as servicing and cleaning schedules, are customer responsibility. Those miscellaneous adjustments noted are customer responsibility. Proper attention to preventative maintenance and scheduled maintenance procedures will prolong the life of the appliance.
7. Travel mileage is limited to **sixty (60) miles** from an Authorized Service Agency or one of its sub-service agencies.
8. All labor shall be performed during regular working hours. Overtime premium will be charged to the buyer.
9. All genuine Wells replacement parts are warranted for ninety (90) days from date of purchase on non-warranty equipment. This parts warranty is limited only to replacement of the defective part(s). **Any use of non-genuine Wells parts completely voids any warranty.**
10. Installation, labor, and job check-outs are **not** considered warranty and are thus **not** covered by this warranty.
11. Charges incurred by delays, waiting time or operating restrictions that hinder the service technician's ability to perform service are **not** covered by warranty. This includes institutional and correctional facilities.

SHIPPING DAMAGE CLAIM PROCEDURE

NOTE: For your protection, please note that equipment in this shipment was carefully inspected and packaged by skilled personnel before leaving the factory. Upon acceptance of this shipment, the transportation company assumes full responsibility for its safe delivery.

IF SHIPMENT ARRIVES DAMAGED:

1. **VISIBLE LOSS OR DAMAGE:** Be certain that any visible loss or damage is noted on the freight bill or express receipt, and that the note of loss or damage is signed by the delivery person.
2. **FILE CLAIM FOR DAMAGE IMMEDIATELY:** Regardless of the extent of the damage.

3. **CONCEALED LOSS OR DAMAGE:** if damage is unnoticed until the merchandise is unpacked, notify the transportation company or carrier immediately, and file "CONCEALED DAMAGE" claim with them. This should be done within fifteen (15) days from the date the delivery was made to you. Be sure to retain the container for inspection.

Wells Bloomfield cannot assume liability for damage or loss incurred in transit. We will, however, at your request, supply you with the necessary documents to support your claim.

TABLE OF CONTENTS

WARRANTY	xi
SPECIFICATIONS	1
FEATURES & OPERATING CONTROLS	2
AGENCY LISTING INFORMATION	3
PRECAUTIONS & GENERAL INFORMATION	4
INSTALLATION	5
OPERATION	7
CLEANING INSTRUCTIONS	8
TROUBLESHOOTING SUGGESTIONS	9
EXPLODED VIEW & PARTS LIST	10
WIRING & VACUUM DIAGRAM	11
PARTS & SERVICE	13
CUSTOMER SERVICE DATA	13

INTRODUCTION

Thank You for purchasing this Wells Bloomfield appliance.

Proper installation, professional operation and consistent maintenance of this appliance will ensure that it gives you the very best performance and a long, economical service life.

This manual contains the information needed to properly install this appliance, and to use and care for the appliance in a manner which will ensure its optimum performance.

SPECIFICATIONS

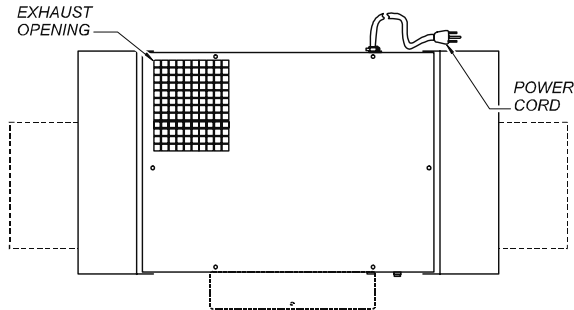

ELECTRICAL SPECIFICATIONS			
MODEL	VOLTS	AMPS 1 ϕ	POWER SUPPLY CORD
WVSW	120	2.6	NEMA 5-15P
	208 - 240	1.3	NEMA 6-15P

CHECK NAMEPLATE FOR PROPER VOLTAGE AND PLUG CONFIGURATION

INSTALLED WEIGHT OF HOOD 92 lbs (42.7 kg)

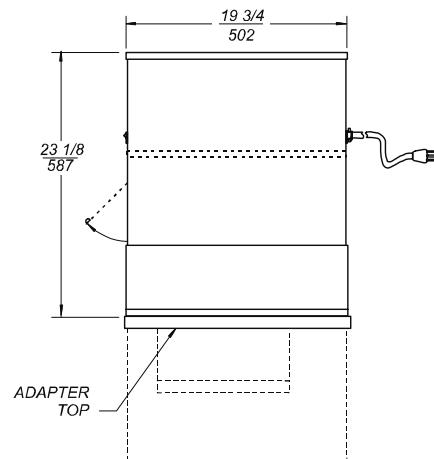
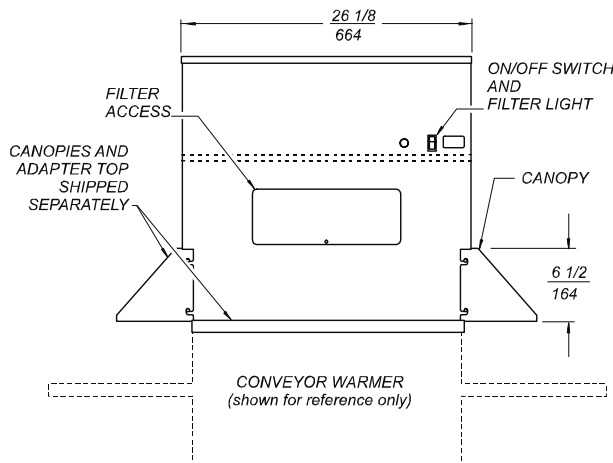

FEATURES & OPERATING CONTROLS

WVSW VENTLESS HOOD

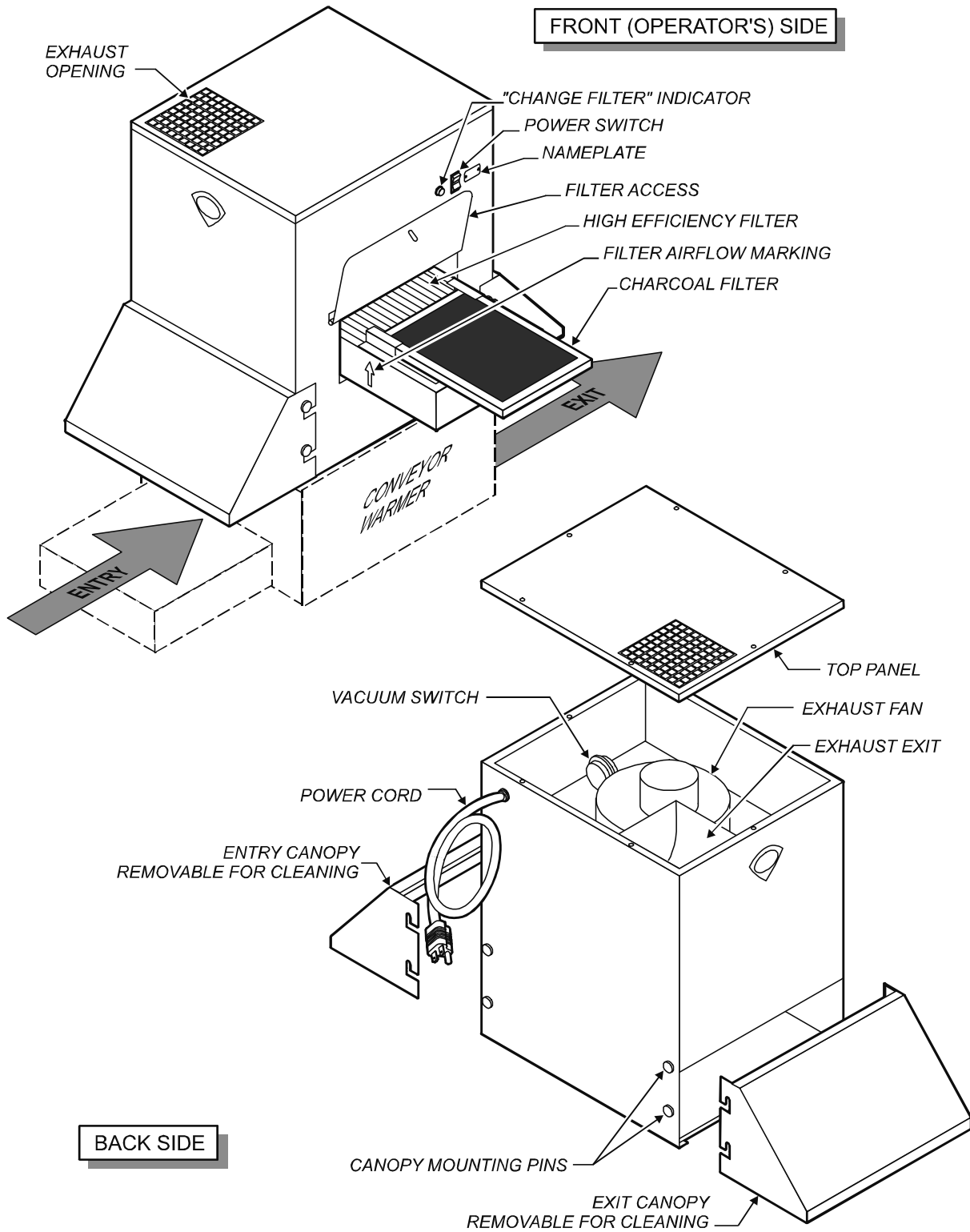

M531 p/n 2M-305812 Owners Manual for Conveyor Hood

Fig. 1 Features & Operating Controls

FEATURES & OPERATING CONTROLS (continued)

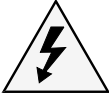
ITEM	DESCRIPTION
CANOPY	Removable canopies aid in vapor capture at entry and exit of the conveyor warmer. Canopies hang from mounting pins at each end of the hood.
ELECTRICAL	The hood plugs into a NEMA 5-15R (120V) or 6-15R (208/240V) receptacle with a 6' power cord. An illuminated power switch on the front panel is used to start/stop the hood fan.
EXHAUST	The hood uses an exhaust fan to provide air movement. The fan exhausts through a screened opening in the top of the hood. IMPORTANT: DO NOT block exhaust opening.
FILTERS	The hood uses two filters. A high efficiency filter is used to capture particulate emissions. A charcoal filter is used to help control odors. Filters are accessed by opening a hinged panel on the front (operator's) side of the hood. Filter operation is monitored by a vacuum switch. When the filter(s) become loaded to the point of being unable to remove particulates, a front panel "change filters" indicator will glow.
NAMEPLATE	Provides Manufacturer, Model and Serial Number information. Also, provides electrical ratings.
TOP PANEL	<div style="display: flex; align-items: center;">  <div> <p>CAUTION! ELECTRIC SHOCK HAZARD EXPOSED ELECTRIC CIRCUITS</p> <p>Top panel must be opened ONLY by qualified personnel. Allows access to interior components. DO NOT stack anything on top of the hood.</p> </div> </div>

AGENCY LISTING INFORMATION

This appliance conforms to NSF Standard 4 for sanitation only if installed and maintained according to the instructions in this manual.



This appliance is  Listed for 120V and 208 - 240V.



This appliance is  Listed for 120V and 208 - 240V.

IMPORTANT: For use with conveyor warmer of 9,000 watts maximum.



NOTE: This ductless hood has not been evaluated to the requirements of NFPA 96.
Local jurisdictions may require additional evaluations for installation of this product.

PRECAUTIONS AND GENERAL INFORMATION



WARNING: ELECTRIC SHOCK HAZARD

All servicing requiring access to non-insulated electrical components must be performed by a factory authorized technician.
DO NOT open or remove the top panel. Failure to follow this warning can result in severe electrical shock.



CAUTION: RISK OF DAMAGE

DO NOT connect or energize this appliance until all installation instructions are read and followed. Damage to the appliance will result if these instructions are not followed.



CAUTION: HOT SURFACE

Exposed surfaces can be hot to the touch and may cause burns.

This appliance is intended for use in commercial establishments only.

This appliance is intended as a smoke and odor control device, designed for use with specified warming equipment. No other use is recommended or authorized by the manufacturer or its agents.

Operators of this appliance must be familiar with the appliance use, limitations and associated restrictions. Operating instructions must be read and understood by all persons using or installing this appliance.

Cleanliness of this appliance is essential to good sanitation. Read and follow all included cleaning instructions and schedules to ensure the safety of the food product.

Disconnect this appliance from electrical power before performing any maintenance or servicing.

DO NOT submerge this appliance in water. This appliance is not jet stream approved. Do not direct water jet or steam jet at this appliance, or at any control panel or wiring. Do not splash or pour water on, in or over any controls, control panel or wiring. Do not wash floor around this appliance with water or steam jet.

Exposed surfaces of this appliance can be hot to the touch and may cause burns.

The technical content of this manual, including any wiring diagrams, schematics, parts breakdown illustrations and/or adjustment procedures, is intended for use by qualified technical personnel.

Any procedure which requires the use of tools must be performed by a qualified technician.

This manual is considered to be a permanent part of the appliance. This manual and all supplied instructions, diagrams, schematics, parts breakdown illustrations, notices and labels must remain with the appliance if it is sold or moved to another location.

This appliance is made in the USA. Unless otherwise noted, this appliance has American sizes on all hardware.

INSTALLATION

UNPACKING & INSPECTION

Carefully read all instructions in this manual before starting any installation.

Carefully remove the hood from the carton.

IMPORTANT: Appliance weighs 92 lbs (42.7 kg). Use appropriate care when removing from carton and installing on conveyor warmer.

Remove all protective plastic film, packing materials and accessories from the hood before connecting electrical power or otherwise performing any installation procedure.

Read and understand all labels and diagrams attached to the hood.

Carefully account for all components and accessories before discarding packing materials. Store all accessories in a convenient place for later use.

COMPONENTS:

HIGH EFFICIENCY FILTER
CHARCOAL FILTER

COMPONENTS SHIPPED SEPARATELY

CANOPY (2 ea)
ADAPTER TOP

SETUP

The conveyor-style warmer requires an adapter top (shipped separately) for mounting the hood. Place adapter top on warmer before setting hood in place. Carefully place hood on top of warmer. Orient hood so that power switch is on the same side as the power switch of the warmer. Center hood over the body of the warmer as shown in *Fig. 2* below:

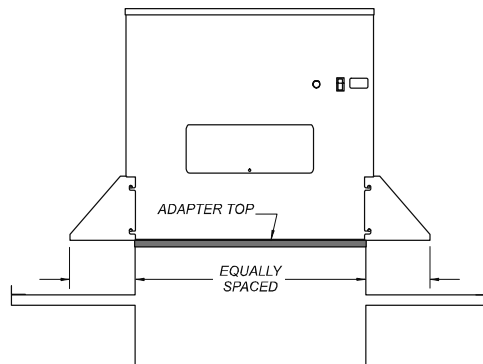

Fig. 2 Hood installation on warmer

Check high efficiency filter and charcoal filter for proper installation. Charcoal filter slides into clips on the high efficiency filter. Airflow marks must point "up".

Attach entry and exit canopies to pins on sides of hood. Canopies are interchangeable and may be mounted at either end.

Maintain required clearances of at least 6" between the appliance and adjacent combustible surfaces.

NOTE: DO NOT discard the carton or other packing materials until you have inspected the hood for hidden damage and tested it for proper operation. Refer to *SHIPPING DAMAGE CLAIM PROCEDURE* on the inside front cover of this manual.



WARNING! RISK OF INJURY

Installation procedures must be performed by a qualified technician with full knowledge of all applicable electrical codes. Failure can result in personal injury and property damage.



CAUTION! RISK OF INJURY AND PROPERTY DAMAGE

Unplug conveyor warmer and allow to cool before beginning installation.

IMPORTANT:

Maintain required clearances of at least 6" between the appliance and adjacent combustible surfaces.

Avoid storing flammable or combustible materials in, on or near the appliance.

INSTALLATION (continued)



WARNING! **ELECTRIC** **SHOCK HAZARD**

All servicing requiring access to non-insulated electrical components must be performed by a factory authorized technician.

DO NOT open any access panel which requires the use of tools. Failure to follow this warning can result in severe electrical shock.



CAUTION! **ELECTRIC** **SHOCK HAZARD**

The ground prong of the power cord is part of a system designed to protect you against electric shock in the event of internal damage. DO NOT cut the ground prong (large round prong) or twist a blade to make the plug fit an existing receptacle.

IMPORTANT:

Contact a licensed electrician to install and connect electrical power to the appliance.

IMPORTANT:

Damage due to being connected to the wrong voltage or phase is NOT covered by warranty.

ELECTRICAL INSTALLATION

Refer to the nameplate. Verify the electrical power source. Voltage and phase must match the nameplate specifications. Plugging the hood into the wrong voltage can severely damage the unit .

Your hood is equipped with a grounded electrical cord. This cord must be plugged into a properly grounded NEMA 5-15R (120V) or NEMA 6-15R (208/240V) single phase receptacle.

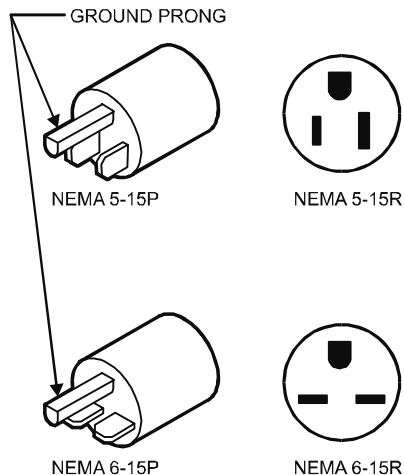

Fig. 3 Electrical Plug and Receptacle Configuration

OPERATING CONTROLS

Controls include a lighted POWER SWITCH and an amber REPLACE FILTER indicator light.

Press POWER SWITCH to ON anytime conveyor warmer is operating.

When power is first turned on, the REPLACE FILTER light will glow. As the fan comes up to speed and air flow is established, the REPLACE FILTER light will go out.

If the REPLACE FILTER light does not go out, the filters must be replaced. However, the fan will continue to operate when the REPLACE FILTER light is lit.



Fig. 4 Operating Controls

FILTER REMOVAL AND INSTALLATION

Disconnect power from hood and conveyor warmer before servicing filters.

Remove screw from filter access panel on front (operator's) side of hood. Slide filter pack (high efficiency filter and charcoal filter) from filter chamber.

Slide new filter pack into filter chamber. Be sure airflow markings on both filters point "up".

Close access panel and reinstall screw.

IMPORTANT:

Filters are disposable. Never attempt to wash either filter. Filters will absorb water if washed, causing food contamination and possible equipment damage.



**CAUTION!
RISK OF INJURY**

Disconnect power from hood and conveyor warmer before servicing filters.

IMPORTANT:

DO NOT store anything on top of the hood.

DO NOT block the exhaust opening.

IMPORTANT:

Both the high efficiency and charcoal filters must be in place at all times during operation.

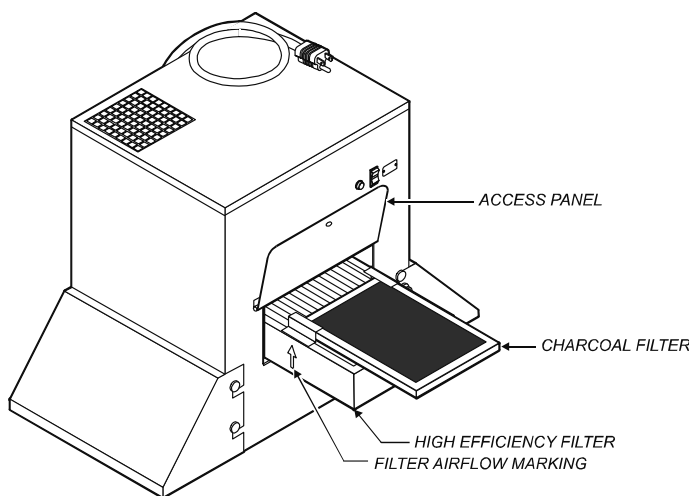

Fig. 5 Filter Installation

CLEANING INSTRUCTIONS



CAUTION! RISK OF INJURY

Disconnect power from hood and conveyor warmer before cleaning.

PREPARATION

Unplug hood and conveyor warmer
Allow to cool completely before cleaning

FREQUENCY

Daily

TOOLS

Mild Detergent
Soft Cloth or Sponge

IMPORTANT: DO NOT spill or pour water into controls, control panel or wiring.

DO NOT spill or pour water into exhaust opening.

DO NOT submerge hood in water or wash with water or steam spray. Damage to internal components will occur.

Damage to internal components from water damage is **not** covered by warranty.

1. Disconnect power from hood and conveyor warmer before cleaning.
2. Remove entry and exit canopies. Canopies may be washed in a sink or dishwasher. Rinse and dry canopies thoroughly.
3. Wipe interior and exterior surfaces of hood with a soft cloth or sponge dampened with water and a mild detergent.

IMPORTANT:

Never attempt to wash either filter.

Filters will absorb water if washed, causing food contamination and possible equipment damage.

4. Rinse all washed areas by wiping with a clean soft cloth dampened with clean water. Dry with a soft cloth.
5. Reinstall entry and exit canopies.

Procedure is complete

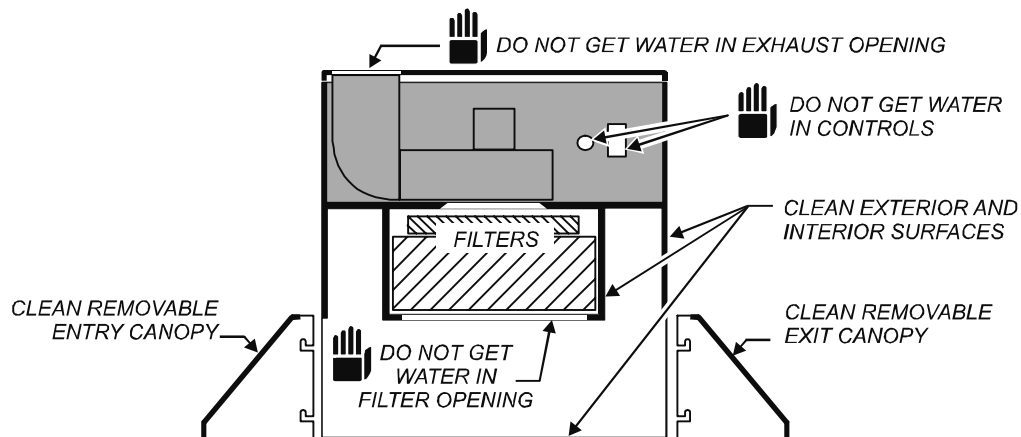

TROUBLESHOOTING SUGGESTIONS

SYMPTOM	PROBABLE CAUSE	CORRECTIVE ACTION
No operation, no lights	Cord unplugged	Plug cord into appropriate power receptacle.
	Circuit breaker off or tripped	Reset circuit breaker
	Damaged power cord or plug	Replace power cord
	Damaged power switch	Replace power switch
REPLACE FILTER light remains lit (never shuts off)	Filters dirty	Replace filters
If filters are clean and fan is operating	New filter still in plastic wrapper	Remove plastic wrapper
	Exhaust opening blocked	Clear or clean exhaust duct and opening
	Filter opening blocked	Clear filter opening
	Vacuum hose kinked	Unkink vacuum hose
	Vacuum line plugged	Clean or replace vacuum line
	Damaged vacuum switch	Replace vacuum switch
If fan is not operating	Fan jammed	Unjam fan
	Damaged motor start capacitor	Replace start capacitor
	Damaged fan motor	Replace fan motor

IMPORTANT:

DO NOT store anything on top of the hood.

DO NOT block the exhaust opening.

Filter operation is monitored by a vacuum switch and a system of vacuum hoses. The vacuum switch energizes the REPLACE FILTER light if airflow through the filters is insufficient for efficient operation. The light is a warning only, and does not control the operation of the hood.

EXPLODED VIEW & PARTS LIST

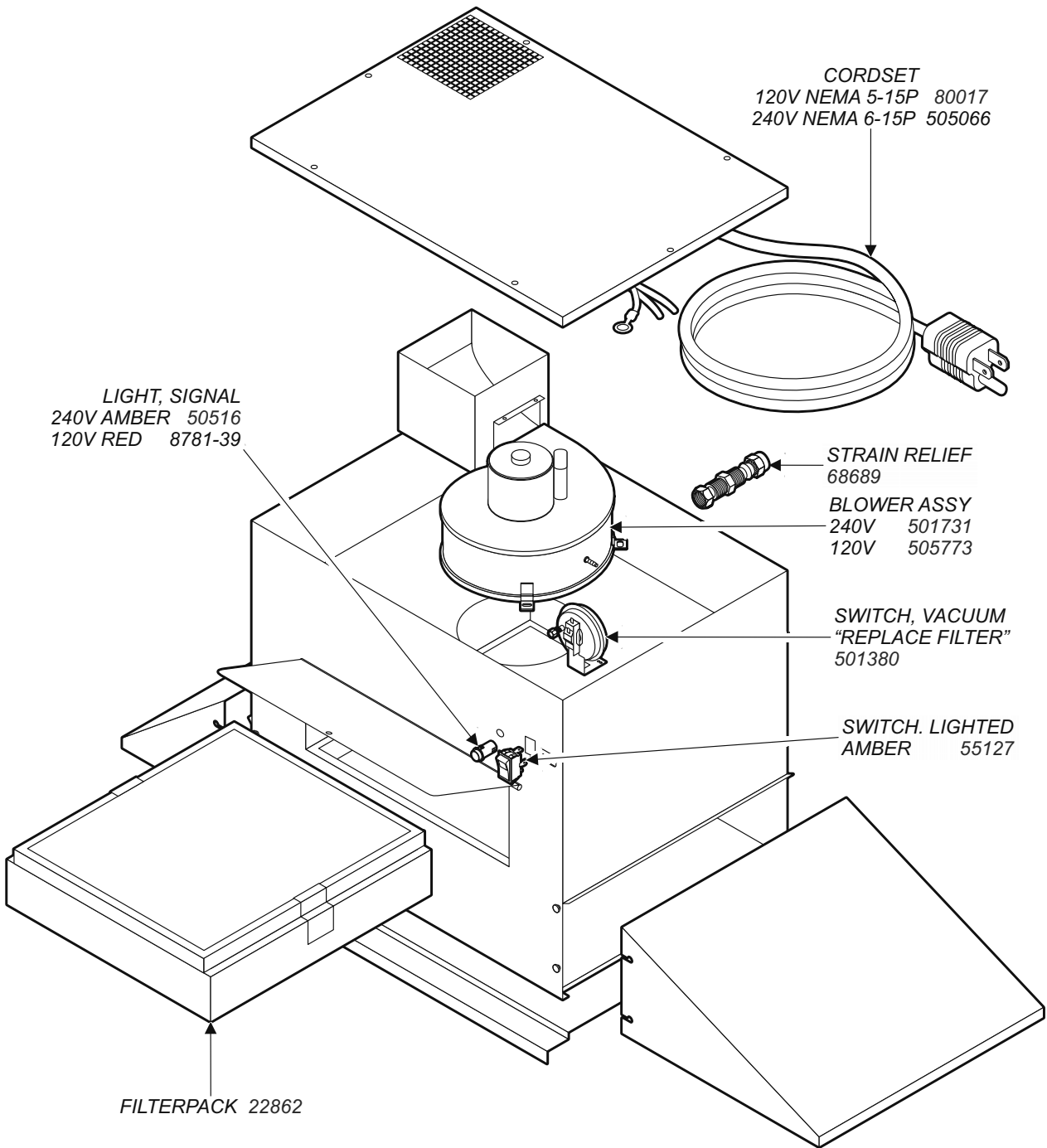

LIGHT, SIGNAL
240V AMBER 50516
120V RED 8781-39

CORDSET
120V NEMA 5-15P 80017
240V NEMA 6-15P 505066

STRAIN RELIEF
68689

BLOWER ASSY
240V 501731
120V 505773

SWITCH, VACUUM
"REPLACE FILTER"
501380

SWITCH, LIGHTED
AMBER 55127

FILTERPACK 22862

M531 p/n 2M-305812 Owners Manual for Conveyor Hood

WIRING & VACUUM DIAGRAM

VACUUM DIAGRAM

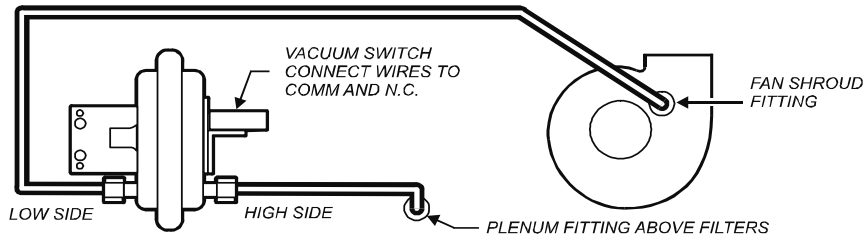

WIRING DIAGRAM

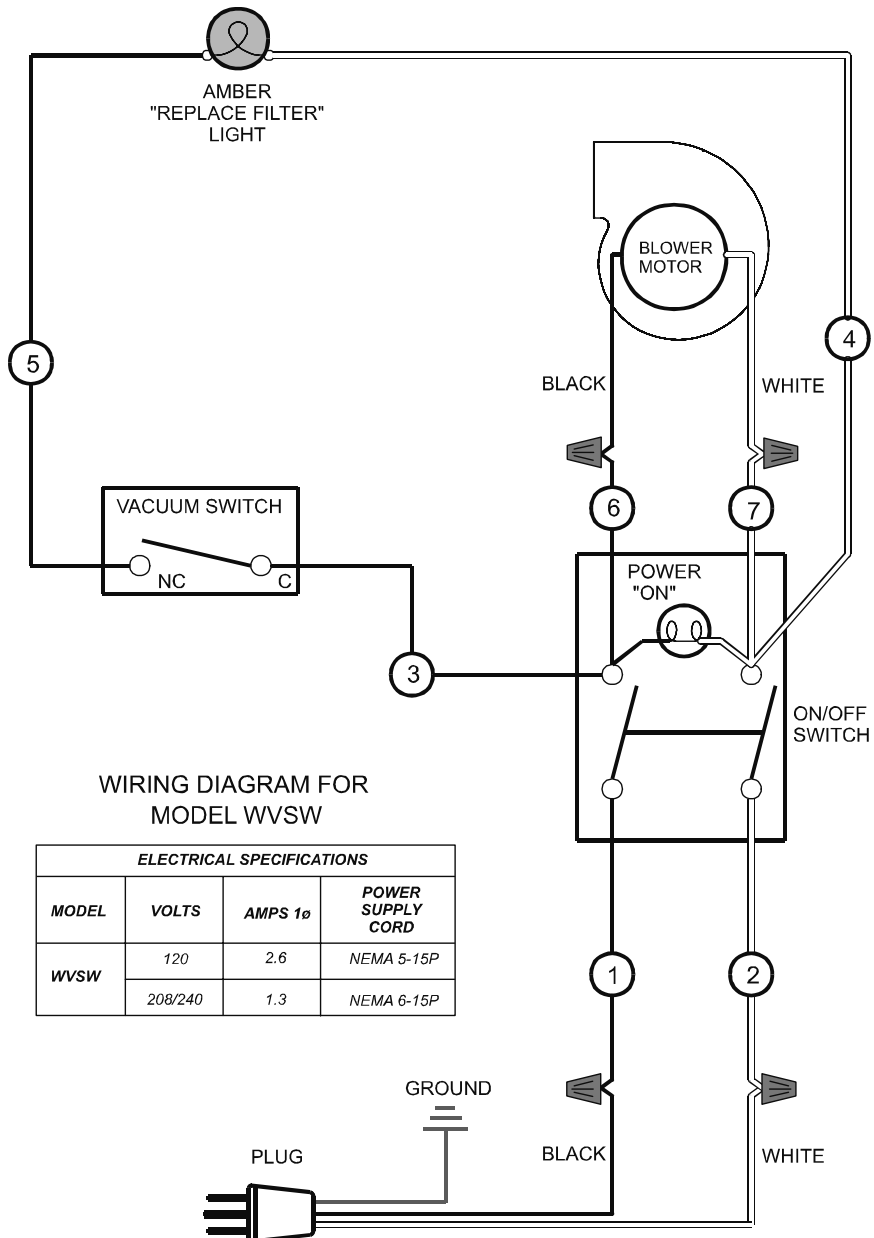

WIRING DIAGRAM FOR
MODEL WWSW

ELECTRICAL SPECIFICATIONS			
MODEL	VOLTS	AMPS 1 ϕ	POWER SUPPLY CORD
WWSW	120	2.6	NEMA 5-15P
	208/240	1.3	NEMA 6-15P

NOTES

PARTS & SERVICE

DESCRIPTION

PART NO.

HIGH EFFICIENCY FILTER 16 x 20x 4

22862

CHARCOAL (CARBON) FILTER 14 x 20 x 7/8

22403

IMPORTANT: Use only factory authorized service parts and replacement filters.

For factory authorized service, or to order factory authorized replacement parts, contact your Wells authorized service agency, or call:

Wells Bloomfield, LLC
10 Sunnen Dr., P.O.Box 430129
St. Louis MO 63143 USA

Service Dept.
phone: (314) 781-2777
fax: (314) 781-2714

Service Parts Department can supply you with the name and telephone number of the **WELLS AUTHORIZED SERVICE AGENCY** nearest you.

CUSTOMER SERVICE DATA

please have this information available if calling for service

RESTAURANT _____ LOCATION _____

INSTALLATION DATE _____ TECHNICIAN _____

SERVICE COMPANY _____

ADDRESS _____ STATE _____ ZIP _____

TELEPHONE NUMBER (____) _____ - _____

EQUIPMENT MODEL NO. _____

EQUIPMENT SERIAL NO. _____

VOLTAGE: (check one) 120 208 240



Wells Bloomfield proudly supports CFESA
Commercial Food Equipment Service Association

SERVICE TRAINING - QUALITY SERVICE



CUSTOMER SATISFACTION

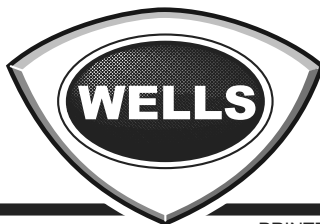

WELLS BLOOMFIELD, LLC
10 Sunnen Drive P.O.Box 430195
St. Louis, MO 63143 USA
telephone: 314-781-2777
fax: 314-781-2714
www.wellsbloomfield.com

PRINTED IN UNITED STATES OF AMERICA