

WELLS MANUFACTURING
265 Hobson Street, Smithville, TN 37166
telephone: 314-678-6314
fax: 314-781-2714
www.wells-mfg.com

522

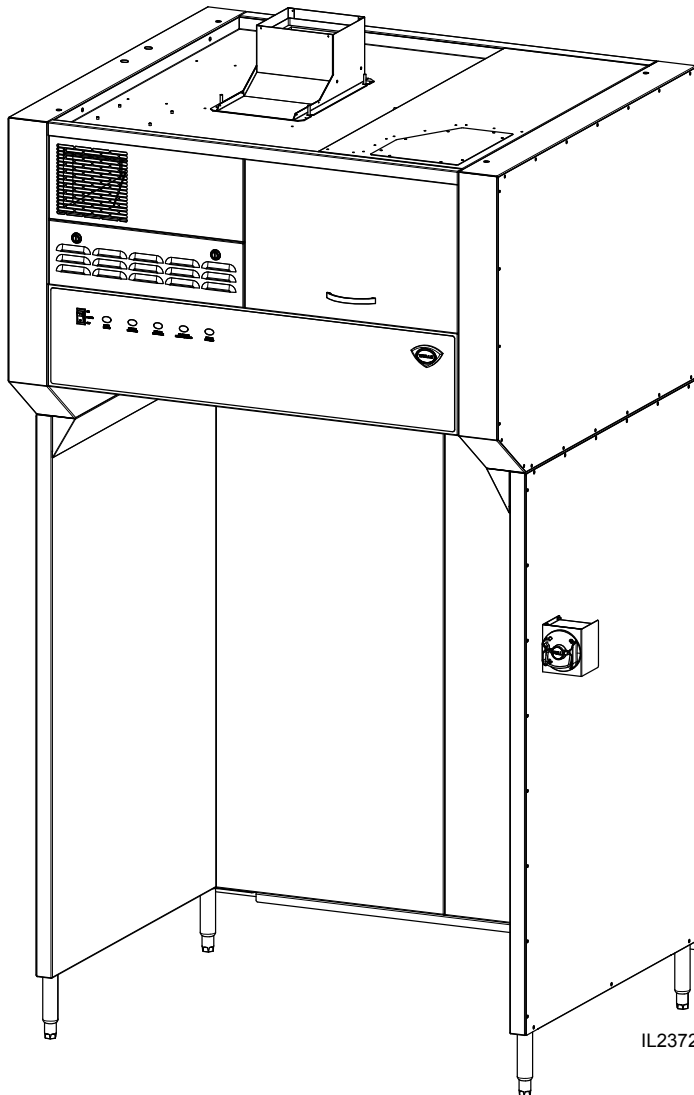

OWNER'S MANUAL
VENTLESS UNIVERSAL
HOOD SYSTEM
for
ELECTRIC
COOKING
APPLIANCES

MODEL
WVU48
WVU96

Manual Includes
INSTALLATION
USE & CARE
EXPLODED VIEW
PARTS LIST
WIRING DIAGRAM

IMPORTANT: DO NOT DISCARD THIS MANUAL

This manual is considered to be part of the appliance and is to be given to the OWNER or MANAGER of the restaurant, or to the person responsible for TRAINING OPERATORS of this appliance. Additional manuals are available from your WELLS DEALER.

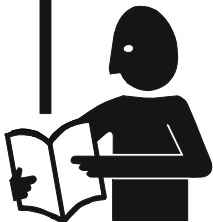

THIS MANUAL MUST BE READ AND UNDERSTOOD BY ALL PERSONS USING OR INSTALLING THIS APPLIANCE. Contact your WELLS DEALER if you have any questions concerning installation, operation or maintenance of this equipment.

LIMITED EQUIPMENT WARRANTY

Wells Manufacturing warranties new products to be free from defects in material and/or workmanship for a period of one [1] year from the date of original installation, except as noted below. Defects that occur as a result of normal use, within the time period and limitations defined in this warranty, will at Wells' discretion have the parts replaced or repaired by Wells or a Wells-authorized service agency.

THIS WARRANTY IS SUBJECT TO ALL LISTED CONDITIONS.

Repairs performed under this warranty are to be performed by a Wells-authorized service agency. Wells will not be responsible for charges incurred or service performed by non-authorized repair agencies.

In all cases, the nearest Wells-authorized service agency must be used.

Wells will be responsible for normal labor charges incurred in the repair or replacement of a warrantied product within 50 miles (80.5 km) of an authorized service agency. Time and expense charges for anything beyond that distance will be the responsibility of the owner. All labor will need to be performed during regular service hours. Any overtime premium will be charged to the owner. For all shipments outside the U.S.A. and Canada, please see the International Warranty for specific details.

It is the responsibility of the owner to inspect and report any shipping damage claims, hidden or otherwise, promptly following delivery.

No mileage or travel charges will be honored on any equipment that is deemed portable. In general, equipment with a cord and plug weighing less than 50 lb. (22.7 kg) is considered portable and should be taken or shipped to the closest authorized service agency, transportation prepaid.

CONTACT

Should you require any assistance regarding the operation or maintenance of any Wells equipment; write, phone, fax or email our service department. In all correspondence mention the model number and the serial number of your unit, as well as the voltage or type of gas you are using.

Business hours are 8:00 a.m. to 4:30 p.m. Central Standard Time
 Telephone 314.678.6314
 Fax 314.781.2714
 Email customerservice@star-mfg.com
 www.wells-mfg.com

WARRANTY EXCLUSIONS

THE FOLLOWING WILL NOT BE COVERED UNDER WARRANTY.

- Any product which has not been installed, cleaned, maintained, or used in accordance with the directions published in the appropriate installation sheet and/or owner's manual as well as national and local codes, including incorrect gas or electrical connection. Wells is not liable for any unit which has been mishandled, abused, misapplied, subjected to chlorides, harsh chemicals, or caustic cleaners, damaged from exposure to hard water, modified by unauthorized personnel, damaged by flood, fire, or other acts of nature [or God], or which have an altered or missing serial number.
- Installation, labor, and job checkouts, calibration of heat controls, air and gas burner/bypass/pilot adjustments, gas or electrical system checks, voltage and phase conversions, cleaning of equipment, or seasoning of griddle surface.
- Replacement of fuses or resetting of circuit breakers, safety controls, or reset buttons.
- Replacement of broken or damaged glass components, quartz heating elements, and light bulbs.
- Labor charges for all removable parts in gas charbroilers and hotplates, including but not limited to burners, grates, and radiants.
- Any labor charges incurred by delays, waiting time, or operating restrictions that hinder a service technician's ability to perform service.
- Parts that fail or are damaged due to normal wear or labor for replacement of Items that can easily be replaced during a daily cleaning routine. such as but not limited to silicone belts, PTFE non-stick sheets, knobs, control labels, bulbs, fuses, quartz heating elements, baskets, racks, and grease drawers.
- Components that should be replaced when damaged or worn, but have been field-repaired instead [eg. field-welded fry pots].
- Any loss of business or profits.

ADDITIONAL WARRANTIES

Specialty/chain specific versions may also have additional and/or extended warranties.

PRODUCTS	PARTS	LABOR
universal ventless hoods	2 years	1 year
canopy hoods	2 years	1 year
"Cook'n Hold" equipment [HW10, HWSMP, LLSC7, LLSC7WA, LLSC11, and LLSC11WA]	2 years	1 year
cast iron grates, burners, and burner shields	1 year	
original Wells parts sold to repair Wells equipment	90 days	
Service First	1 year	

TABLE OF CONTENTS

GENERAL WARRANTY STATEMENT	
ELECTRICAL SPECIFICATIONS	1
FEATURES & OPERATING CONTROLS	2-3
PRECAUTIONS & GENERAL INFORMATION	4
AGENCY LISTING INFORMATION	5
INSTALLATION	5
Unpacking & Inspection	5
Components	5
Under-Hood Appliance Limitations	6-7
Service Technician Installation Notes	8
Base Assembly	9-10
Electrical Installation	11-12
ANSUL® INSTALLATION & SETUP	13-14
Filter Installation	15
OPERATION	16
Operation Lights	16
CLEANING INSTRUCTIONS	17-18
DISCHARGE DIRECTION CHANGE	19
REQUIRED MAINTENANCE & MAINTENANCE LOGS	20-24
TROUBLESHOOTING SUGGESTIONS	25
WIRING DIAGRAM	26-27
EXPLODED VIEW & PARTS LIST	28-37
PARTS & SERVICE	38
CUSTOMER SERVICE DATA	38

INTRODUCTION

Thank You for purchasing this Wells Manufacturing appliance.

Proper installation, professional operation and consistent maintenance of this appliance will ensure that it gives you the very best performance and a long, economical service life.

This manual contains information and instructions for the ventless ventilation hood, its use and care.

For information regarding cooking appliance(s), please refer to the manufacturer's operation manual.

ELECTRICAL SPECIFICATIONS

Model	Volts	Amps	Power Supply
WVU48	208/240V	3.5	For supply connection use #12 AWG copper wire only.
WVU96		8.0	

FEATURES & OPERATING CONTROLS

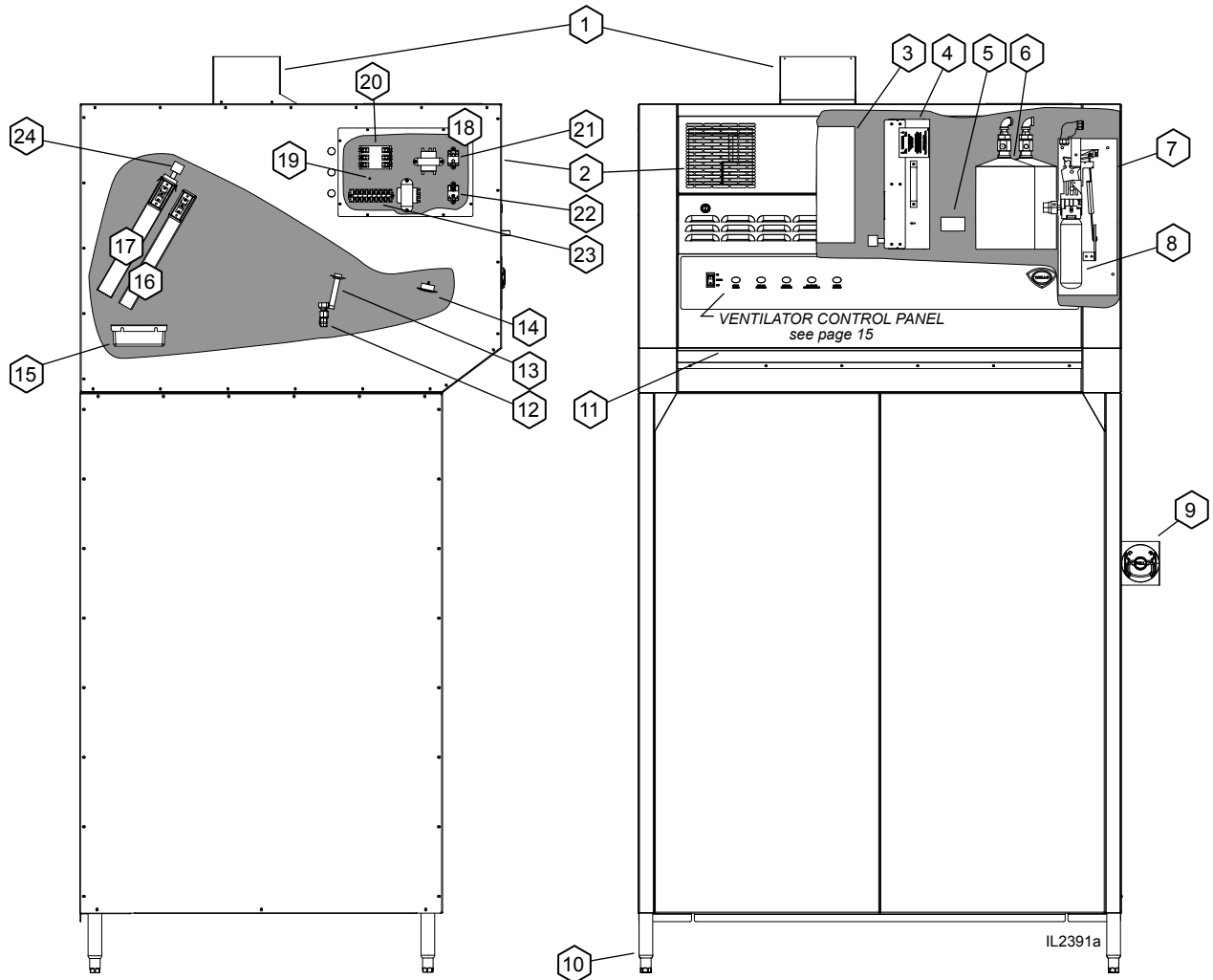

Ventilator Section Operating Features & Controls

FEATURES & OPERATING CONTROLS continued

FEATURES & OPERATION CONTROLS		
ITEM NO	DESCRIPTION	COMMENT
1	VENTILATOR EXHAUST DUCT, TOP	Exit point for ventilator airflow - on top of unit. DO NOT BLOCK
2	VENTILATOR EXHAUST DUCT, FRONT	Exit point for ventilator airflow - on front of unit. DO NOT BLOCK
3	VENTILATOR FAN	Provides air movement for ventilation
4	HI-EFFICIENCY/CHARCOAL FILTER PACK	Removes grease and smoke particles. Also assists in cooking odor removal.
5	NAMEPLATE	Gives manufacturer, make and model description. Also list voltage and amperage data.
6	FIRE SUPPRESSION TANK	Container for ANSUL® Low-pH Liquid fire suppression fluid.
7	ACTUATOR ASSY	Triggers deployment of suppression fluid through manual pull station or electric detection.
8	ANSUL® CARTRIDGE	Propels suppression liquid through suppression manifold and nozzles.
9	MANUAL PULL STATION	Provides a means of manual activation of the fire suppression system. PULL ONLY IN CASE OF FIRE!
10	ADJUSTABLE LEGS	Allows the unit to be leveled.
11	AIR WALL	A wall of air that moves the grease and smoke particles into the filter system.
12	DISCHARGE NOZZLES	Fire suppression media discharges here, (6 places 48", 12 places 96")
13	ELECTRICAL DETECTORS	Designed to activate at certain temperature. Activates (i.e. fire on the cooktop) activates fire suppression system. Should be checked every 6 months during ANSUL® Service Inspection
14	APPLIANCE LIGHT	ON when hood power switch is ON. Illuminates cooking area.
15	GREASE DRIP TRAY	Collects grease/moisture dripping from baffle filter (16)
16	BAFFLE FILTER	Extracts and drains most greases and moisture from the air flow.
17	PRE-FILTER ASSEMBLY	Comprises the PRE-FILTER FRAME and a replaceable PRE-FILTER. Stops large particles of grease from reaching the FILTER PACK for reduced maintenance costs.
18	ELECTRICAL CONNECTION BOX	Houses electrical components
19	GROUND LUG	Ground wire of power connection connects here.
20	EQUIPMENT INTERFACE CONTACTOR	Energizes cooking appliances only while ventilator section is sensed as operational.
21	BUILDING FIRE ALARM RELAY	Reports fire alarm condition to building fire management system.
22	DETECTION END OF LINE RELAY	Prevents appliance operation if a fault is found in detection circuit.
23	SUPPLY CONNECTION TERMINAL BLOCK	Provides connection point for electrical circuitry
24	FILTER INTERLOCK SWITCHES	Proper installation of baffle filter and filter pack closes these switches in ventilator sensor circuit

PRECAUTIONS AND GENERAL INFORMATION

DANGER

DANGER: **SUFFOCATION HAZARD**

Do not attempt to use this ventilator with gas-fired units. This ventilator will not remove products of combustion. Unvented exhaust gasses can be deadly.

WARNING

WARNING: **SHOCK HAZARD**

All servicing requiring access to non-insulated electrical components must be performed by a factory authorized technician.

DO NOT open any access panel which requires the use of tools. Failure to follow this warning can result in severe electrical shock.

IMPORTANT:

The ventilator is disabled when the filters are plugged to the point of insufficient airflow for proper operation. Also, power to the cooking appliances is interrupted if any filters or service panel are removed.

It is the responsibility of the store management to maintain sufficient spares of filter packs to avoid prolonged shutdown due to a dirty or clogged filter pack. Filter packs cannot be cleaned.

Wells Manufacturing assumes no liability for loss of business due to a filter related shutdown. Spare filters can be purchased from any authorized Wells servicer or calling Wells.

This ventilator hood is part of an engineered system and is intended for use in commercial establishments only.

This ventilator is intended for commercial establishments for use in the preparation food for human consumption. No other use is recommended or authorized by the manufacturer or its agents.

Operators of this appliance must be familiar with the appliance use, limitations and associated restrictions. Operating instructions must be read and understood by all persons using or installing this appliance.

This ventilator hood system is designed to reduce odor emissions, but will not completely eliminate all cooking odors. Air exchange rates at the installation site must comply with the requirements of the local jurisdictional authority. To ensure that odors do not accumulate, recommended minimum air exchange is 200 cfm per linear foot of hood into and out of the site.

This unit is intended for use with light- and medium duty electric cooking appliances only. Cooking appliances placed under this ventilator must comply with the restrictions set forth in the *Installation section of this manual*.

Do not connect or energize this appliance until all installation instructions are read and understood. Property damage or bodily injury may result if these instructions are not followed. Disconnect this appliance from electrical power before performing any maintenance or servicing.

Cleanliness of this appliance is essential to good sanitation. Read and follow all included cleaning instructions and schedules to ensure the safety of the food product.

This appliance is not jet steam approved. Do not direct water jet or steam jet at this appliance, or at any control panel or wiring. Do not splash or pour water on, in or over any controls, control panel or wiring. Do not attempt to wash filter packs. Water will cause their immediate failure and disable the ventilator.

Exposed surfaces of this appliance can be hot to the touch and may cause burns.

Avoid storing flammable or combustible materials in, on or near the ventilator or associated cooking appliance.

The technical content of this manual, including any wiring diagrams, schematics, parts breakdown illustrations and/or adjustment procedures, is intended for use by qualified technical personnel.

Any procedure which requires the use of tools must be performed by a qualified technician.

All supplied instructions, diagrams, schematics, parts breakdown illustrations, notices and labels must remain with the appliance if the unit is sold or moved to another location.

This appliance is made in the USA. Unless otherwise noted, this appliance has American sizes on all hardware.

Warranty for this unit is 2 years for parts and 1 year for labor with proper installation/start-up and maintenance.

AGENCY LISTING INFORMATION

SANITATION



NSF/ANSI 2



UL710B

Recirculating System

This appliance conforms to NSF Standard 2 for sanitation only if installed in accordance with the supplied *Installation Instructions* and operated and maintained in accordance with the instructions in this manual.

UL CLASSIFIED for use in US and Canada

INSTALLATION

UNPACKING & INSPECTION

Carefully remove the appliance from the carton. Remove all protective plastic film, packing materials and accessories from the appliance before connecting electrical power or otherwise performing any installation procedure.

Carefully read all instructions in this manual and any other documents packed with the appliance before starting any installation. All documentation should remain with the equipment operator for future reference.

Read and understand all labels and diagrams attached to the ventilator.

Carefully account for all components and accessories before discarding packing materials.

COMPONENTS

	4 ft	8 ft
Pre-Filter	2 ea.	4 ea.
Baffle Filter	2 ea.	4 ea.
Filter pack	1 ea.	2 ea.
Grease cup	1 ea.	2 ea.

Ansul® components - must be installed by an authorized Ansul® distributor only:

	4 ft	8 ft
2 ea.	4 ea.	Fire suppression agent tank
2 ea.	4 ea.	Fire suppression agent (Ansulex® Low pH) 1.5 gal.
1 ea.	2 ea.	Fire suppression system charging cartridge

Store these components in a convenient place for later use.

The unit is shipped configured for horizontal discharge of the exhaust. To convert to vertical discharge:

1. Remove top access cover.
2. Remove internal turning vane.
3. Insert top discharge scoop assy and fasten w/hardware from cover.
4. Remove front discharge vent panel and damper assy.
5. Assemble damper in Top discharge scoop assy.
6. Replace front discharge vent panel.

NOTE: DO NOT discard the carton or other packing materials until you have inspected the appliance for hidden damage and tested it for proper operation. Refer to *SHIPPING DAMAGE CLAIM PROCEDURE* on the inside front cover of this manual.



WARNING: RISK OF INJURY

Installation procedures must be performed by a qualified technician with full knowledge of all applicable electrical codes. Failure can result in personal injury and property damage.

IMPORTANT:

Fire suppression system must be charged and certified by an authorized Ansul® distributor. Ventilator will not operate and cooking appliance will not be energized until the Ansul® fire suppression system has been charged.

IMPORTANT:

After cooking appliances are positioned under the hood, swivel nozzles must be positioned per Ansul® recommendations.

INSTALLATION (continued)

UNDER-HOOD APPLIANCE LIMITATIONS:

GENERAL LAYOUT DATA
SANITATION

MODEL WVU-48SS UNIVERSAL VENTLESS HOOD SYSTEM



NSF/ANSI 2 UL710B

VOLTAGE AC 60 HZ	AMPS 1 PH	HORSE POWER	TYPICAL AIRFLOW	MAX GREASE EMISSIONS	CLEARANCE TO COMBUSTIBLES	SOUND LEVEL dBA AVG	UNDER HOOD LED LIGHTING
208/240	3.5	3/4	1500 CFM	.0024 LB/HR/FT	N/A	68	1485 LUMENS

UL CAT. YZCT RECIRCULATING SYSTEM FILE NO. MH48408

SPECIAL ENVIRONMENTAL NOTICE: THE HOOD SYSTEM IS DESIGNED TO REDUCE EMISSIONS BUT WILL NOT COMPLETELY ELIMINATE COOKING AROMAS. AIR EXCHANGE AT THE INSTALLATION SITE MUST COMPLY WITH REQUIREMENTS OF THE LOCAL JURISDICTIONAL AUTHORITY. A MINIMUM OF 800 CUBIC FEET OF FRESH AIR PER MINUTE INTO THE AREA IS RECOMMENDED TO ENSURE ADEQUATE DILUTION.

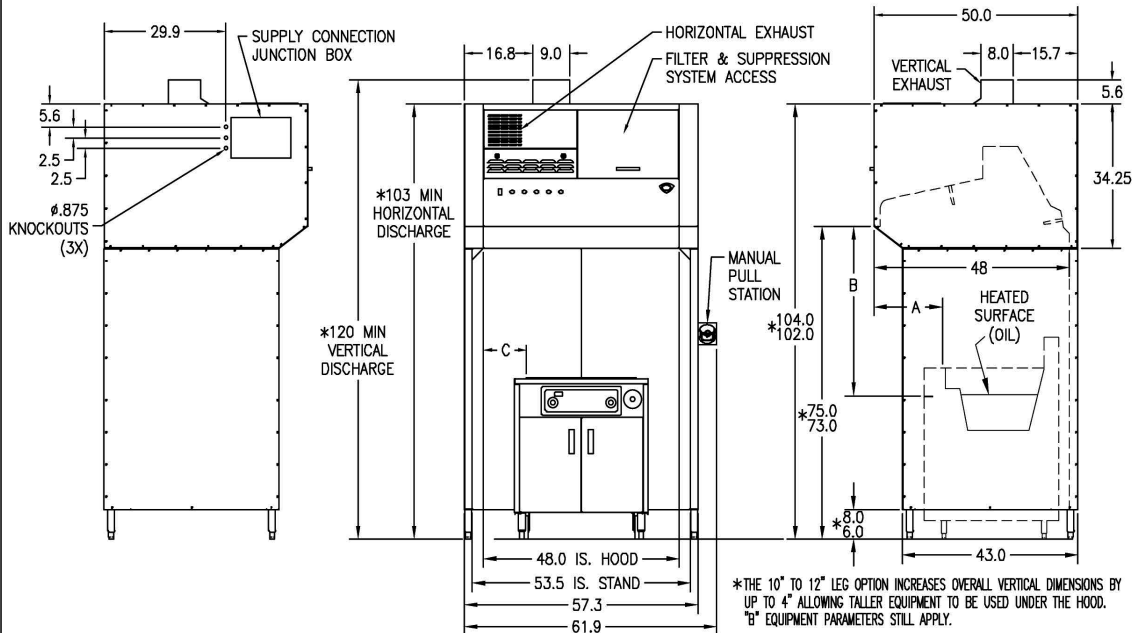

EQUIPMENT PARAMETERS APPLIANCE TYPE	MAXIMUM KW/FT	MAX COOKING TEMPERATURE	MAXIMUM SINGLE APPLIANCE HEATED COOKING SURFACE LENGTH	DIM A (3) MINIMUM	DIM B (4) MINIMUM	DIM B (4) MAXIMUM	DIM C (5) MINIMUM
FRYER	16.9	400	18	14 (EDGE OF OIL)	37	42	0
GRIDDLE	5.5	450	36	21 (EDGE OF HEATED PLATE)	37	42	1
RANGE (2) /HOTPLATE	5.5	N/A	48	21 (EDGE OF HEATED PLATTEN)	37	42	1
WOK	7.0	N/A	48	21 (EDGE OF HEATED SURFACE)	37	42	0
VERTICAL BROILER	7.0	N/A	25	20 (EDGE OF HEATED SURFACE)	10	N/A	0
OVEN	N/A	575	48	6 (FRONT EDGE OF DOOR)	8	N/A	0
BRAISING PAN/SKILLET (1)	4.5	550	48	14 (EDGE OF HEATED SURFACE)	37	42	0
CONVECTION OVEN	N/A	575	48	6 (FRONT EDGE OF DOOR)	8	N/A	0
STEAMER / COMBI OVEN	N/A	575	48	6 (TOP EDGE OF DOOR)	20	N/A	0
STEAM JACKETED KETTLE	16.9	450	48	14 (EDGE OF OF HEATED SURFACE)	30	42	0
SANDWICH GRILL (1)	4.5	550	36	18 (EDGE OF HEATED PLATTEN)	30	42	0
CONVEYOR OVEN	4.5	N/A	23	6 (EDGE OF HEATED SURFACE)	20	42	0

- (1) LID MUST NOT INTERFERE WITH SUPPRESSION NOZZLE DISCHARGE PATTERN.
- (2) PLUS OVEN KW IF APPLICABLE.
- (3) FRONT OF HOOD TO FRONT EDGE OF HEATED COOKING SURFACE.
- (4) BOTTOM FRONT EDGE OF HOOD TO HEIGHT OF HEATED COOKING SURFACE.
- (5) INSIDE OF HOOD SIDE TO EDGE OF HEATED COOKING SURFACE.

THE HOOD AND ALL UNDER HOOD APPLIANCES MUST BE INSTALLED IN ACCORDANCE WITH THE STANDARD FOR VENTILATION CONTROL AND FIRE PROTECTION OF COMMERCIAL COOKING OPERATIONS NFPA 96, THE NATIONAL ELECTRIC CODE NFPA 70 AND ALL LOCAL CODES WHERE APPLICABLE. ALL UNDER HOOD APPLIANCES MUST BE INSTALLED AS PER MANUFACTURER INSTRUCTIONS AND CONTROLLED BY THE HOOD EQUIPMENT SHUTOFF INTERFACE THROUGH A CUSTOMER SUPPLIED CONTACTOR. SEE THE INSTRUCTION MANUAL FOR INTERFACE CONNECTION OPTIONS. APPLIANCES MUST MEET EQUIPMENT PARAMETERS DESCRIBED ABOVE. ONLY ELECTRICALLY HEATED APPLIANCES ARE ACCEPTABLE FOR INSTALLATION. PRIOR TO OPERATION THE FIRE SUPPRESSION SYSTEM MUST BE CHARGED AND CERTIFIED BY AN ANSUL® AUTHORIZED DISTRIBUTOR. ADEQUATE SIDE CLEARANCE MUST BE PROVIDED FOR SUPPLY CONNECTION AND SUPPRESSION MANUAL PULL ACCESS. EXHAUST IS SHIPPED FOR HORIZONTAL DISCHARGE AND FIELD CONVERTIBLE FOR VERTICAL DISCHARGE.

NOTE: SPECIFICATIONS SUBJECT TO CHANGE WITHOUT NOTICE.

SK2547 REV (F) 4/15/2016

M522 p/n 2M-Z16247 OpM WVU- Universal Hood

INSTALLATION (continued)

UNDER-HOOD APPLIANCE LIMITATIONS:

GENERAL LAYOUT DATA
SANITATION



NSF/ANSI 2 UL710B

MODEL WVU-96SS UNIVERSAL VENTLESS HOOD SYSTEM

VOLTAGE AC 60 HZ	AMPS 1 PH	HORSE POWER	TYPICAL AIRFLOW	MAX GREASE EMISSIONS	CLEARANCE TO COMBUSTIBLES	SOUND LEVEL dBA AVG	UNDER HOOD LED LIGHTING
208/240	8.0	1.5	3000 CFM	.0024 LB/HR/FT	N/A	70	2970 LUMENS

UL CAT. YZCT RECIRCULATING SYSTEM FILE NO. MH48408

SPECIAL ENVIRONMENTAL NOTICE: THE HOOD SYSTEM IS DESIGNED TO REDUCE EMISSIONS BUT WILL NOT COMPLETELY ELIMINATE COOKING AROMAS. AIR EXCHANGE AT THE INSTALLATION SITE MUST COMPLY WITH REQUIREMENTS OF THE LOCAL JURISDICTIONAL AUTHORITY. A MINIMUM OF 1600 CUBIC FEET OF FRESH AIR PER MINUTE INTO THE AREA IS RECOMMENDED TO ENSURE ADEQUATE DILUTION.

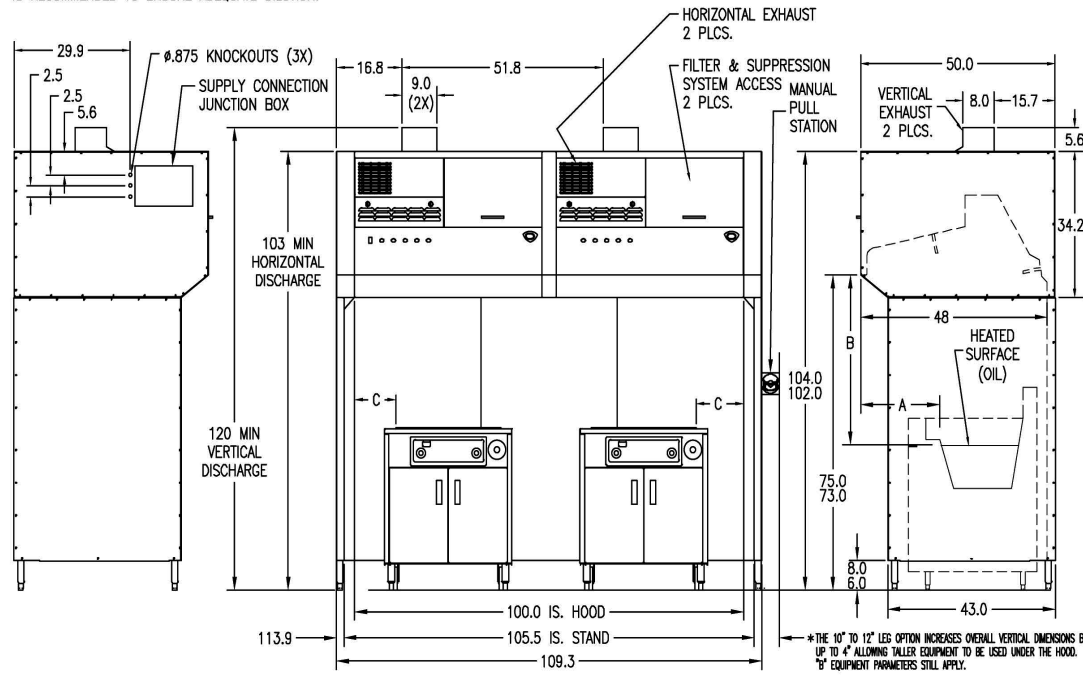

*THE 10" TO 12" LES OPTION INCREASES OVERALL VERTICAL DIMENSIONS BY UP TO 4" ALLOWING TALLER EQUIPMENT TO BE USED UNDER THE HOOD. IF EQUIPMENT PARAMETERS STILL APPLY.

EQUIPMENT PARAMETERS APPLIANCE TYPE	MAXIMUM KW/FT	MAX COOKING TEMPERATURE	MAXIMUM SINGLE APPLIANCE HEATED COOKING SURFACE LENGTH	DIM A (3) MINIMUM	DIM B (4) MINIMUM	DIM B (4) MAXIMUM	DIM C (5) MINIMUM
FRYER	16.9	400	18	14 (EDGE OF OIL)	37	42	0
GRIDDLE	5.5	450	36	21 (EDGE OF HEATED PLATE)	37	42	1
RANGE (2) /HOTPLATE	5.5	N/A	48	21 (EDGE OF HEATED PLATTEN)	37	42	1
WOK	7.0	N/A	48	21 (EDGE OF HEATED SURFACE)	37	42	0
VERTICAL BROILER	7.0	N/A	25	20 (EDGE OF HEATED SURFACE)	10	N/A	0
OVEN	N/A	575	48	6 (FRONT EDGE OF DOOR)	8	N/A	0
BRAISING PAN/SKILLET (1)	4.5	550	48	14 (EDGE OF HEATED SURFACE)	37	42	0
CONVECTION OVEN	N/A	575	48	6 (FRONT EDGE OF DOOR)	8	N/A	0
STEAMER / COMBI OVEN	N/A	575	48	6 (TOP EDGE OF DOOR)	20	N/A	0
STEAM JACKETED KETTLE	16.9	450	48	14 (EDGE OF OF HEATED SURFACE)	30	42	0
SANDWICH GRILL (1)	4.5	550	36	18 (EDGE OF HEATED PLATTEN)	30	42	0
CONVEYOR OVEN	4.5	N/A	23	6 (EDGE OF HEATED SURFACE)	20	42	0

- (1) LID MUST NOT INTERFERE WITH SUPPRESSION NOZZLE DISCHARGE PATTERN.
- (2) PLUS OVEN KW IF APPLICABLE.
- (3) FRONT OF HOOD TO FRONT EDGE OF HEATED COOKING SURFACE.
- (4) BOTTOM FRONT EDGE OF HOOD TO HEIGHT OF HEATED COOKING SURFACE.
- (5) INSIDE OF HOOD SIDE TO EDGE OF COOKING SURFACE.

THE HOOD AND ALL UNDER HOOD APPLIANCES MUST BE INSTALLED IN ACCORDANCE WITH THE STANDARD FOR VENTILATION CONTROL AND FIRE PROTECTION OF COMMERCIAL COOKING OPERATIONS NFPA 96, THE NATIONAL ELECTRIC CODE NFPA 70 AND ALL LOCAL CODES WHERE APPLICABLE. ALL UNDER HOOD APPLIANCES MUST BE INSTALLED AS PER MANUFACTURER INSTRUCTIONS AND CONTROLLED BY THE HOOD EQUIPMENT SHUTOFF INTERFACE THROUGH A CUSTOMER SUPPLIED CONTACTOR. SEE THE INSTRUCTION MANUAL FOR INTERFACE CONNECTION OPTIONS. APPLIANCES MUST MEET EQUIPMENT PARAMETERS DESCRIBED ABOVE. ONLY ELECTRICALLY HEATED APPLIANCES ARE ACCEPTABLE FOR INSTALLATION. PRIOR TO OPERATION THE FIRE SUPPRESSION SYSTEM MUST BE CHARGED AND CERTIFIED BY AN ANSUL® AUTHORIZED DISTRIBUTOR. ADEQUATE SIDE CLEARANCE MUST BE PROVIDED FOR SUPPLY CONNECTION AND SUPPRESSION MANUAL PULL ACCESS. EXHAUST IS SHIPPED FOR HORIZONTAL DISCHARGE AND FIELD CONVERTIBLE FOR VERTICAL DISCHARGE.

NOTE: SPECIFICATIONS SUBJECT TO CHANGE WITHOUT NOTICE.

SK2552 REV (F) 4/19/2016

M522 p/n 2M-Z16247 OpM WVU- Universal Hood

INSTALLATION (continued)

SERVICE TECHNICIAN INSTALLATION NOTES

This ventilator hood is to be used with light-duty and medium-duty electrically powered cooking appliances only.

- DO NOT attempt to use this ventilator hood with gas-fired units.
- DO NOT use this ventilator hood with electrical appliances whose dimensions or wattage characteristics exceed those defined in the Under Hood Cooking Appliance Limitations, page 6.

Installation and start up must be performed by an Authorized Installation Company.

Ansul® Installer must complete the WARRANTY INITIATION form (2M-303912) included with the unit for the warranty to begin, and record installation particulars on the CUSTOMER SERVICE DATA form located at the end of this manual.

IT IS THE RESPONSIBILITY OF THE INSTALLER TO verify that this VENTILATOR installation is in compliance with the specifications listed in this manual, with local code requirements, and in accordance with N.F.P.A 96 the STANDARD FOR VENTILATION CONTROL AND FIRE PROTECTION OF COMMERCIAL COOKING OPERATIONS.

NOTE: Certain codes require FRYERS to be restrained with a TETHER or other RESTRAINT DEVICE. If this ventilator is to be used with a fryer, it is the RESPONSIBILITY OF THE INSTALLER to check with the AUTHORITY HAVING JURISDICTION, in order to ascertain the applicability of this requirement to this specific installation .

SETUP

Setup the appliance only on a firm, level, non-combustible surface. Verify local codes for requirements. Concrete, tile, terrazzo or metal surfaces are recommended. Metal over combustible material may not meet code for non-combustible surfaces.

Verify vertical clearances. Ceiling height shall be no less than 103" inches when utilizing horizontal discharge option. Ceiling height shall be no less than 120" inches when utilizing vertical discharge option.

Verify that the unit sits firmly on ALL LEGS. With a spirit level, check that the appliance is level front-to-back and side-to-side. With the adjustable legs, adjust as required to level the appliance. In order to prevent tipping or deflection, legs must be adjusted such that all legs are in firm contact with the floor.

DANGER

DANGER: SUFFOCATION HAZARD

Do not attempt to use this ventilator with gas-fired units. This ventilator will not remove products of combustion. Unvented exhaust gasses can be deadly.



WARNING: SHOCK HAZARD

All servicing requiring access to non-insulated electrical components must be performed by a factory authorized technician.

DO NOT open any access panel which requires the use of tools. Failure to follow this warning can result in severe electrical shock.



CAUTION: RISK OF DAMAGE

DO NOT connect or energize this appliance until all installation instructions are read and followed. Property damage or bodily injury could result if these instructions are not followed.

IMPORTANT:

If a remote pull station is to be used, ventilator cannot be moved without first disabling the remote pull station.

Contact your Ansul® agent for details.

INSTALLATION (continued)

Hardware Provided

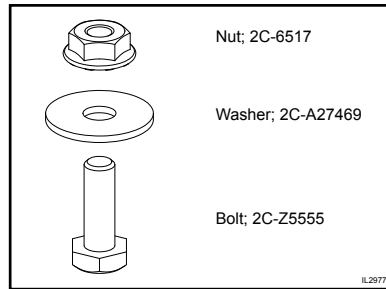

BASE ASSEMBLY

Prior to assembling the base, locate it as close to the final position as possible. Then follow these steps.

1. Align the two rear panels (Fig 1) and secure with a bolt, washer and nut (8 places).
2. Place the Base Bottom Stiffener (N1-Z15330) to the bottom of the two rear panels and secure with bolt, washer and nut (8 places).
3. Align the left and right side of the base to the rear panel (Fig 2) and secure with bolt, washer and nut (8 places each side).
4. Align the rear corner brackets in place (Fig 3) and secure with bolt, washer and nut (4 places each bracket).
5. Install the 6" adjustable legs and secure in place with the bolt provided.

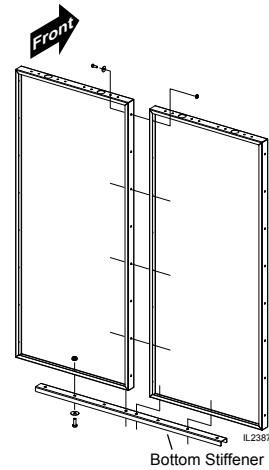

Figure 1

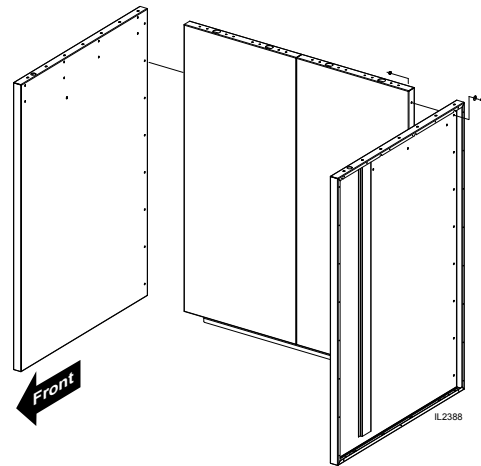

Figure 2

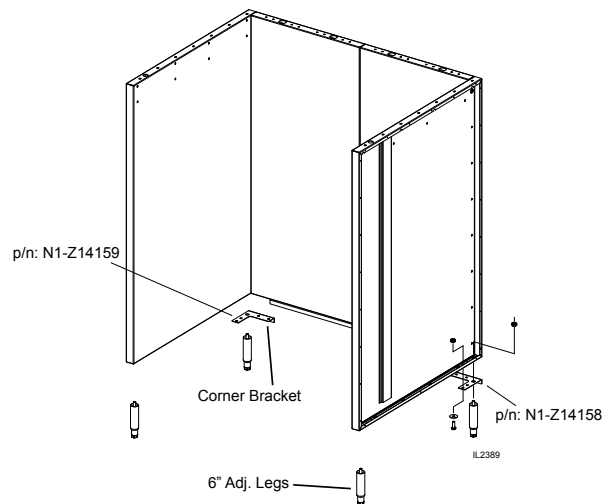

Figure 3

INSTALLATION (continued)

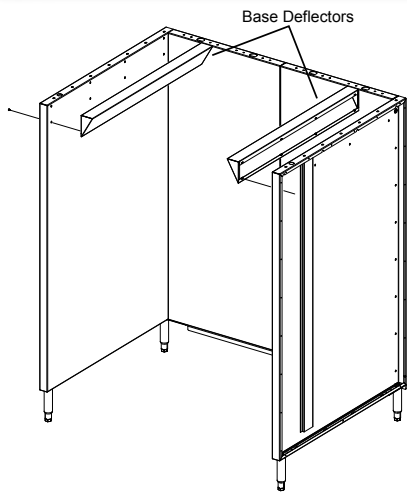

Figure 4

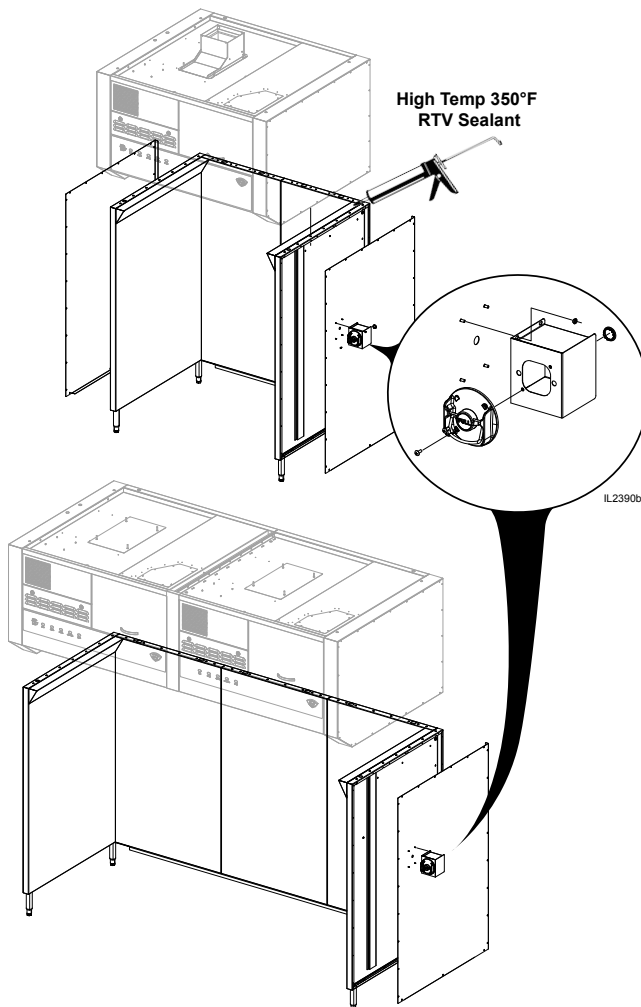

Figure 5

6. Align the two base deflectors (Fig 4) in place and secure with screws (8 per deflector)
7. Move the base into position, and using a level, adjust the legs until level.
8. Remove the side panels of the hood assembly so when lowered onto the base assembly it will be easier to secure in place.
9. Apply a bead of RTV Sealant with a temperature rating of 375°F on the base (*between the base and hood, once hood is lowered*) as shown in (Fig 5). Follow the warning that come with the sealant. **DO NOT** allow a film to form on the bead before lowering the hood down on the base. If a film forms, remove the bead and re-apply a new bead.

IMPORTANT: BEFORE APPLYING RTV SEALANT, CLEAN ALL RECEIVING SURFACES OF ANY DIRT, GREASE OR FORGIEN MATERIAL.

10. Using the upper supporting brackets on the hood, lower the hood on top of the base (Fig 5) so the mounting holes line up. Secure with bolt, washer and nut (7 places each side).
11. Contact your electrical & Ansul® contractors to provide service to the system. Refer to the *ELECTRICAL INSTALLATION & FIRE SUPPRESSION SYSTEM INSTALLATION sections in this manual.*
12. Once complete the side panels can be installed using hardware provided.

INSTALLATION



DANGER: SUFFOCATION HAZARD

Do not attempt to use this ventilator with gas-fired units. This ventilator will not remove products of combustion. Unvented exhaust gasses can be deadly.



WARNING SHOCK HAZARD

Electrical connections must be made by a licensed electrician.



CAUTION: FIRE HAZARD HEALTH HAZARD

All cooking appliance must be connected to the cooking appliance contactor, the control circuit of which is controlled by the ventilator.

Failure to control cooking appliances will provide no protection in the event of a fire, nor will cooking vapors and odors be contained in the event of ventilator hood

ELECTRICAL INSTALLATION

Refer to the nameplate on the ventilator. Verify ELECTRICAL SERVICE POWER. Voltage and phase must match the nameplate specifications, and available electrical service amperage must meet or exceed the listed amperage. Refer to specifications listed on page 1 of this manual.

The ground lug of this ventilator must be connected to a suitable building ground.

Remove the left side panel to access the cooking appliance contactor and building alarm relay. Remove the appropriate knockout, then wire the cooking appliance control circuit to the terminal block per Fig below.

NOTE: It is the responsibility of the electrical contractor to provide suitable wiring, flexible or rigid conduit, and an appropriate strain relief.

Electrical Connection

NOTE: The hood requires a single phase (1ph), 208 or 240 volt, 20 amp supply. When connecting line voltage to the unit's terminal block, use a minimum of #12 gage copper wire only, suitable for 167°F (76°C) ambient temperature.

Appliance Connections

All under hood appliances are required to be interlocked with the hood's equipment cut-off circuit, through a customer supplied contactor. This contactor must be a UL listed, definite purpose AC resistive air heating type, suitable for the appliance load. Installation and connections shall be in accordance with the National Electric Code NFPA 70. These connections provide an automatic shutdown of the appliance when the hood is OFF, or in the event of a malfunction or appliance fire.

Equipment Cutoff Connections

- Opt 1: Use TB#3 & TB#4 for 208 or 240 volt control circuit. These contacts will be de-energized when the hood is OFF or in the event of a malfunction
- Opt 2: Use TB#5 & TB#6 as a Normally Closed SPST relay connection for equipment control circuits with voltages other than 208 or 240 AC. These contacts will be open when hood is OFF or in the event of a malfunction.

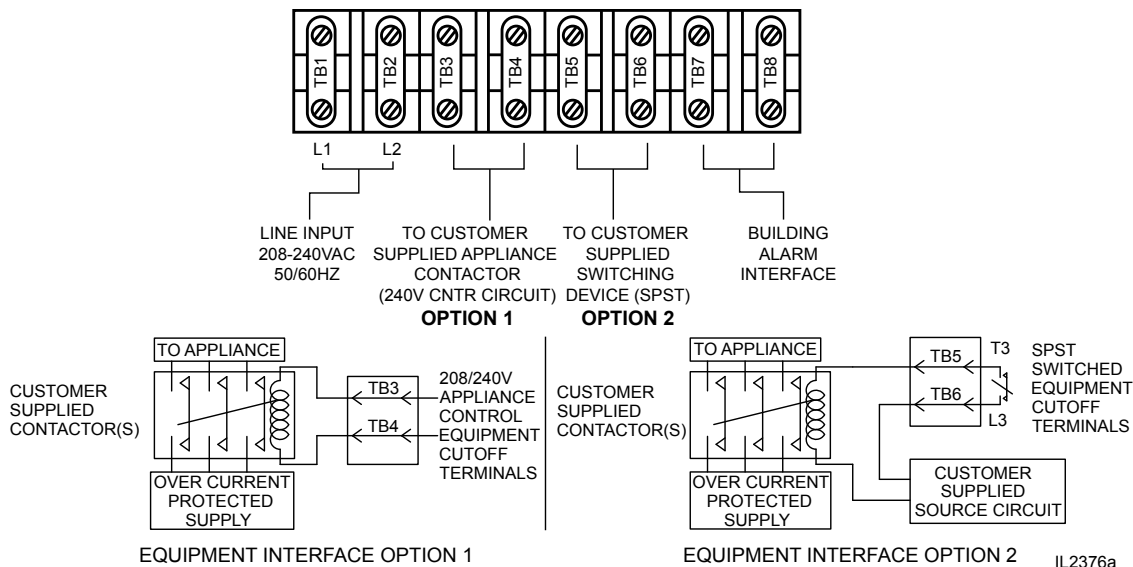

IL2376a

INSTALLATION continued

SUPPLY POWER INSTALLATION

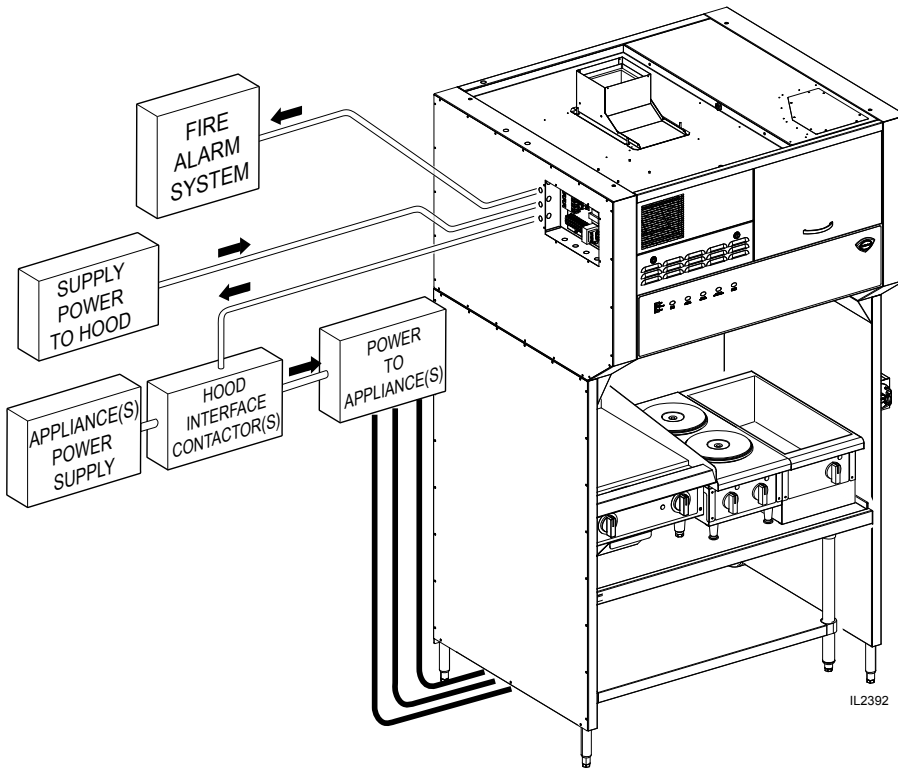

DANGER

DANGER: **SHOCK HAZARD**

Turn power off to the unit before removing the side electrical box cover.



CAUTION: **SHOCK HAZARD**

The ground lug of this appliance must be connected to a suitable building ground.

IMPORTANT:
Contact a licensed electrician to install and connect electrical power to the appliance.

IMPORTANT:
Damage due to being connected to the wrong voltage or phase is NOT covered by warranty.

INSTALLATION continued

DANGER

**DANGER
FIRE HAZARD**

Fire suppression system must be charged and certified by an authorized Ansul® distributor.

DO NOT attempt to modify or bypass the fire suppression system.

An uncontrolled fire can cause serious injury or death.

NOTE:

If the fire suppression system is discharged, a buzzer will sound continuously. The unit will remain inoperable until the fire suppression system is serviced, recharged and reset by an authorized Ansul® distributor.

Charging of the Ansul® Fire Suppression system must be in accordance with Ansul® Design, Installation, Recharge and Maintenance Manual, #418087.

NOTE:

If a REMOTE MANUAL PULL STATION is installed, moving the ventilator for any reason may cause the Ansul® system to discharge.

IMPORTANT:

Should the fire suppression system discharge: all nozzles must be replaced, and all lines thoroughly cleaned, prior to recharging the system.

Residual fire suppression media may compromise the flow and dispersion of fire suppression media in any subsequent activation.

The alarm relay is activated by the Ansul® fire detection system. If the installation includes a building alarm system, connect to terminals T7 & T8 of the terminal block in supply connection box. These terminals are configured from the factory for normally open operation.

The ventilator will operate properly, and the appliance control relay will be energized, only when:

1. The VENTILATOR POWER SWITCH is "ON".
2. The Ansul® Fire Suppression System is charged and armed.
3. All filters are in position and serviceable, and the ventilator air flow system is satisfied.

FIRE SUPPRESSION SYSTEM INSTALLATION

EACH 4' FOOT SECTION OF THE FIRE SUPPRESSION SYSTEM is comprised of two containers of Ansul® Low pH liquid fire suppression media and a system pressurization canister, plus associated plumbing. Actuation controls are contained in the Automan enclosure.

The hood is supplied with a field installed MANUAL PULL STATION, which must be set-up at the time of installation by an authorized Ansul® distributor.

The MANUAL PULL STATION allows for manual emergency shutdown of cooking appliance power, and actuation of the fire suppression system.

Six (*WVU48*) or twelve (*WVU96*) NOZZLES disperse the fire suppression media. Two inner nozzles protect the fan and plenum. The appliance nozzles are swivel mounted, and must be directed toward the cooking surface of the installed cooking appliance.

If the ventilator is situated such that the supplied manual pull station cannot be installed or is not readily accessible, a REMOTE MANUAL PULL STATION may be required by local codes. Any such remote manual pull station must be installed by an authorized Ansul® distributor in accordance with the AUTHORITY HAVING JURISDICTION.

The fire detection system utilizes six (*WVU48*) or twelve (*WVU96*) electronic thermal detectors with an actuation set point of 225°F (107°C) in the upper hood locations and 275°F (135°C) detectors in the lower wall locations. The signaling from any of these detection devices will automatically discharge the fire suppression media through all nozzles, disable the cooking appliances and cause the alarm to sound.

Fire suppression media will form an emulsion designed to both smother and cool the fuels in/on the cooking appliance.

INSTALLATION

FIRE SUPPRESSION SYSTEM INSTALLATION (continued)

The MANUAL PULL STATION and any similar REMOTE MANUAL PULL STATION will activate the fire suppression system when the ring on the pull station is pulled to its full extent.



**DANGER
BURN HAZARD**

Any additional remote pull station must **NOT** be installed on the front of the cooking appliances,

Discharge of the fire extinguishing system into hot grease or oil may cause hot foam to spill over from the cooking surface or frypot.

Serious burns and other injuries can result from contact with hot oil and from slipping in spilled oil.

The manual pull station is installed on the right side (facing the unit). It may, however, be relocated to the left side of the ventilator hood by an authorized Ansul® agent.

INSTALLATION

NOTE:

The BAFFLE FILTERS, PRE-FILTERS and FILTER PACK actuate position switches when they are properly positioned. They must be properly installed for the under hood cooking appliance contactor to be energized.

WARNING
SLIP AND FALL HAZARD

DO NOT operate any grease-producing cooking appliance

(e.g. fryer or griddle) unless the grease cup is properly installed. Oil will drip onto floor creating a slipping hazard.

CAUTION
BURN HAZARD

DO NOT operate any cooking appliance unless the grease cup is installed.

Moisture dripping onto hot surfaces, oil or grease can cause splattering.

FILTER INSTALLATION

Note air flow direction arrow on filter pack. Remove old filter pack and slide new filter pack fully into the appropriate slot. Verify that the airflow arrow points toward the fan.

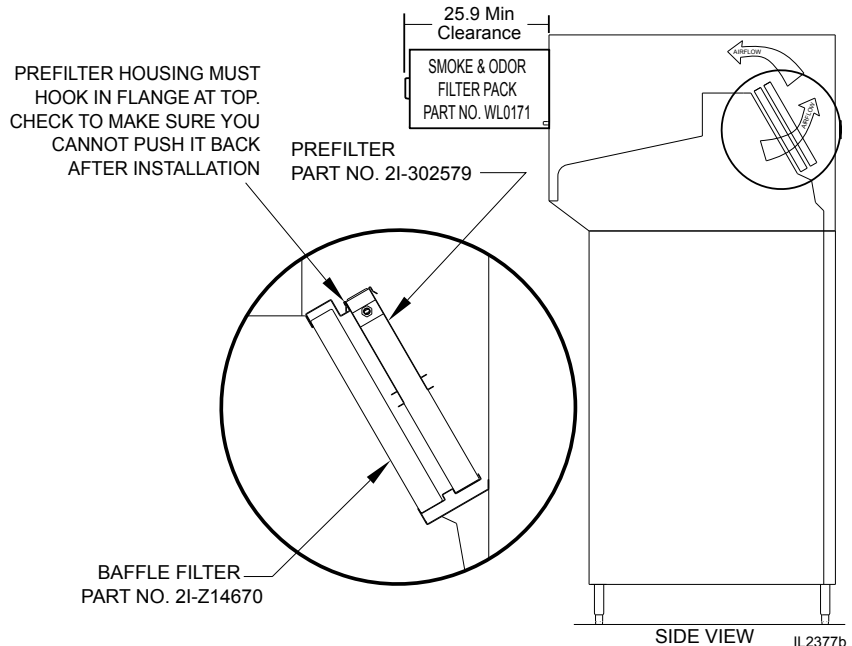

Baffle filters are reusable and should be cleaned at least weekly. Change pre-filters and smoke/odor filter pack as indicated on the front panel. These filters are disposable and cannot be reused. The smoke / odor filter pack is accessed thru the front service door.

Pre-filters are located behind the baffle filters, when installing pre-filters engage top retaining flange prior to seating pre-filter housing in lower chamber.

Use only genuine Wells replacement parts and filters, call (314) 678-6314 or your authorized Wells service agent. Parts supplied by others will void your warranty and may not provide safe operation.

BAFFLE FILTER and GREASE CUP INSTALLATION

1. Install baffle filter from front. Engage the baffle filter in the retainer slot. Push up until the baffle filter bottom clears the lower lip of the retainer, then lower the baffle filter into the bottom retainer
2. Install GREASE CUP into brackets below the baffle filter.

Note: Failure to install the GREASE CUP will allow grease and moisture from the BAFFLE FILTER to drop into hot cooking surfaces, creating both a SAFETY HAZARD (hot oil splatter) and a HEALTH HAZARD (contamination of the cooking surface or cooking oil).

OPERATION

Control Panel

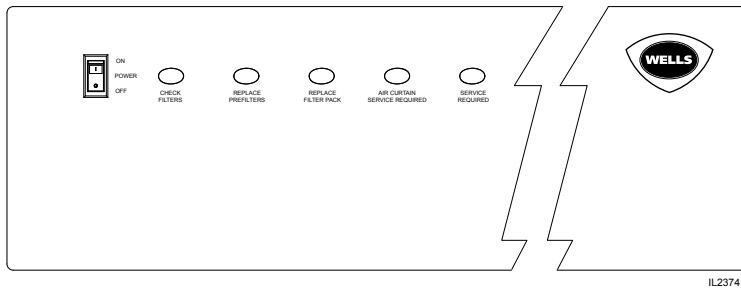

NOTE: Cooking appliances must be operated in accordance with the manufacturer's instructions.

During normal operation, the illuminated power switch will be the only light on the control panel that will be ON.

If the CHECK FILTERS light illuminates, check BAFFLE FILTERS, PREFILTERS, and the HEPA AIR FILTERS for proper installation.

If the REPLACE PRE-FILTERS light illuminates .. Replace the Pre-filters.

If the REPLACE FILTER light illuminates, replace the FILTER PACK.

NOTE: the REPLACE FILTERS light is a warning that filter pack is nearing the end of its service life. The ventilator will continue to operate for a period of time after the REPLACE FILTER LIGHT turns ON to allow continued operation through a peak period. However, filter pack must be replaced within a short time period or it will clog, disabling the ventilator and appliances.

If the SERVICE REQUIRED light illuminates, the filter pack is restricted to the point of insufficient airflow for proper operation and the Ventilator will shut down until the underlying clogged filter situation has been corrected. Replace clogged item with a fresh filter to correct the condition. Reset the unit by turning VENTILATOR POWER SWITCH to OFF, then back to ON.

If the air curtain service required lights illuminate, there is insufficient airflow for proper operation. Call an authorized Wells Service Agent.

A failure of incoming electric power will cause a shut down of the unit. Reset the unit by turning VENTILATOR POWER SWITCH to OFF, then back to ON.

Operation Lights

There are three (WVU48) equipment lights and six on the (WVU96) that provide illumination of the working area. These lights are controlled by the main power switch.



CAUTION: HOT SURFACE

Exposed surfaces can be hot to the touch and may cause burns.



CAUTION: SHOCK HAZARD

DO NOT splash or pour water or grease onto control panel or wiring.

IMPORTANT:

The ventilator cannot operate if the filter pack is removed or clogged.

It is the responsibility of the store management to maintain sufficient spares of filter packs to avoid prolonged shutdown of the ventilator when this filter is expended.

Filter packs cannot be cleaned.

Wells Manufacturing assumes no liability for loss of business due to filter related shutdown.

Filters that are not genuine Wells Replacement Parts may cause your unit to operate incorrectly and you will risk the possibility of voiding your warranty.

CLEANING INSTRUCTIONS



CAUTION: HOT SURFACE

Exposed surfaces can be hot to the touch and may cause burns. Allow unit to cool before cleaning.

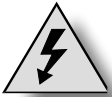

CAUTION: SHOCK HAZARD

DO NOT splash or pour water or grease onto control panel or wiring.

PRECAUTIONS: Disconnect unit from electric power and allow to cool
Cover frypot to prevent oil contamination

FREQUENCY: Daily

TOOLS: Mild detergent, clean non-abrasive towels

NOTE: Ventilator section to be cleaned in conjunction with cooking appliance. Refer to appliance user instructions for cleaning procedure.

1. TURN HOOD POWER SWITCH TO OFF.
Cover cooking appliance to prevent oil contamination.
2. Remove BAFFLE FILTERS and GREASE CUP(s).
3. Empty GREASE CUP(s) into an appropriate grease collection receptacle.
4. Clean BAFFLE FILTERS and GREASE CUP(s) in a sink or dishwasher using mild detergent and warm water.
5. Dry components with a clean non-abrasive cloth. Reinstall BAFFLE FILTERS and GREASE CUP(s) in ventilator.
6. Wipe exterior of ventilator with a clean cloth moistened with warm water and mild detergent. Rinse by wiping with a clean cloth moistened with warm water.
7. Uncover the cooking appliance and reconnect unit to electric power.

Procedure is complete

CLEANING INSTRUCTIONS

PRECAUTIONS: Disconnect unit from electric power and allow to cool
Cover cooking surfaces and frypots to prevent contamination.

FREQUENCY: Monthly

TOOLS: Mild detergent, clean non-abrasive towels

NOTE: Ventilator section to be cleaned in conjunction with cooking appliance. Refer to appliance user instructions for cleaning procedure.



CAUTION: HOT SURFACE

Exposed surfaces can be hot to the touch and may cause burns. Allow unit to cool before cleaning.

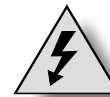

CAUTION: SHOCK HAZARD

DO NOT splash or pour water or grease onto control panel or wiring.

1. TURN HOOD POWER SWITCH TO OFF.
Cover cooking appliance to prevent oil contamination.
2. Remove BAFFLE FILTERS, GREASE CUP(s), and all FILTER PACK(s).
3. Wipe interior of ventilator with a clean cloth moistened with warm water and mild detergent. Rinse by wiping with a clean cloth moistened with warm water. DO NOT clean by spraying.
4. Dry ventilator thoroughly with a clean non-abrasive cloth.
Reinstall all FILTERS, BAFFLE FILTERS, GREASE CUP(s).
5. Uncover the cooking appliance and reconnect unit to electric power.

Procedure is complete

IMPORTANT:

DO NOT wash FILTER PACK. Washing these filters will clog them, and cause installed cooking appliance to be disabled.

IMPORTANT:

DO NOT clean interior of ventilator by spraying.

Spraying can contaminate the cooking appliance, and may cause internal damage to the ventilator blower, operation proofing system and/or fire suppression system.

Clean by wiping only.

MAINTENANCE: DISCHARGE DIRECTION CHANGE

Procedure for changing the discharge on a WVU-48 / 96

PARTS LIST

Fig No	Part No	Description	Qty
1	2C-35487	SCREW 8-32 X 5/16 PH TR HD	AR
2	2C-6517	1/4-20 FLANGED HEX SHAKEPROOF LOCK NUT	AR
3	2V-307913	DAMPER FIRE 8X9	1
4	N1-WL0167	ACCESS DOOR ASSY. ELEC COMPARTMENT	1
5	N1-WL0172	FRONT DUCTWORK ASSEMBLY	1
6	N1-WL0244	TOP DISCHARGE SCOOP ASSEMBLY	1
7	N1-Z14097	FRONT DISCHARGE VENT PANEL	1
8	N1-Z14100	DISCHARGE CURVE	1
9	N1-Z14139	BLOCK-OFF PLATE, TOP DISCHARGE	1

Horizontal to Vertical:

1. Remove the Front Access Door (Item 4) by turning the slotted screws $\frac{1}{4}$ turn and lift out the panel.
2. Remove the Front Discharge Vent Panel (Item 7) by removing the mounting screws.
3. Remove the damper (Item 3).
4. Re-install the Front Access Door and Front Discharge Vent Panel.
5. Remove the Top Discharge Block-Off plate (item 9) by removing the four mounting nuts.
6. Remove the Discharge Curve (Item 8) by removing the two 8-32 screws (Item 1) securing the curve and slide the curve out of the bracket.
7. Install the Vertical discharge assembly (Item 6) and secure with four $\frac{1}{4}$ -20 nuts.
8. Install the damper (Item 3) into the top of the Vertical discharge assembly (Item 6).

Vertical to Horizontal:

1. Remove the damper (Item 3) from the vertical discharge housing (Item 6).
2. Remove the four nuts that secure the Vertical discharge housing (Item 6) to the top panel of the hood.
3. Remove the vertical discharge housing.
4. Insert the discharge curve (Item 8) into the duct as shown. Slide one end of the curve into the bracket located on the rear wall of the duct and secure the front end of the curve with two 8-32 x 5/16 screws (Item 1).
5. Install the block-off plate (Item 9) and secure with four $\frac{1}{2}$ -20 nuts.
6. Remove the Front discharge vent panel (Item 7) and access door (Item 4).
7. Install the damper (Item 3) into the front ductwork assembly (Item 5).
 - a. Note the required orientation of the damper as noted on the damper.
8. Re-install the front discharge vent panel and access door.

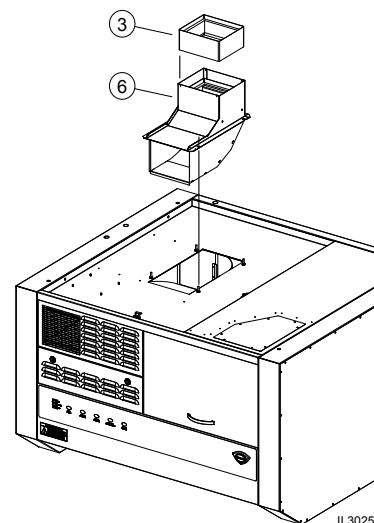
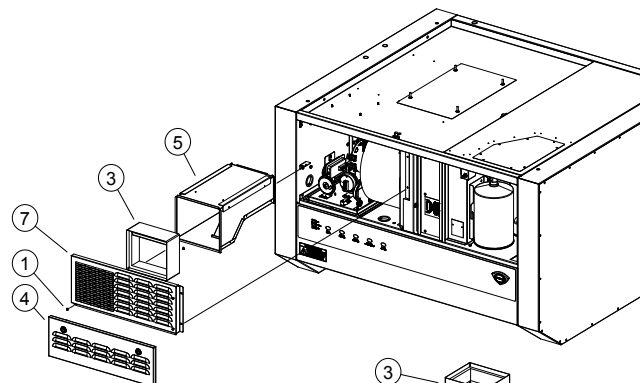
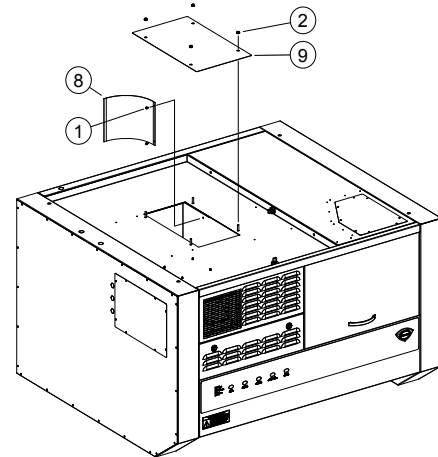

IL3025

REQUIRED MAINTENANCE

IMPORTANT:

Per NFPS 96, a signed and dated VENTILATOR HOOD MAINTENANCE LOG must be maintained on the premises, and be made available for inspection by the authority having jurisdiction upon request.

IMPORTANT:

Should the fire suppression system discharge, all lines and nozzles must be thoroughly cleaned prior to recharging the system.

Be sure to note such cleaning on the hood maintenance log. Residual fire suppression media may compromise the flow and dispersion of fire suppression media in any subsequent activation.

USE AND MAINTENANCE SHALL BE IN ACCORDANCE WITH THE STANDARD FOR VENTILATION CONTROL AND FIRE PROTECTION OF COMMERCIAL COOKING OPERATIONS, N.F.P.A. 96 (current edition).

3-MONTH MAINTENANCE:

Thoroughly clean entire HOOD PLENUM and BLOWER section.

6-MONTH MAINTENANCE:

Inspection and testing of total operation including FIRE DAMPER and all SAFETY INTERLOCKS shall be performed by qualified service personnel.

All FIRE SUPPRESSION SYSTEM actuation components including MANUAL PULL STATION and any REMOTE MANUAL PULL STATION must be inspected for proper operation in accordance with the maintenance schedule published in ANSUL® R-102 SYSTEM DESIGN, INSTALLATION, RECHARGE AND MAINTENANCE MANUAL (418087).

ANNUAL (12-MONTH) MAINTENANCE:

NOZZLES and MANUAL PULL STATION must be cleaned in accordance with ANSUL® R-102 SYSTEM DESIGN, INSTALLATION, RECHARGE AND MAINTENANCE MANUAL (418087).

12-YEAR MAINTENANCE:

The FIRE SUPPRESSION AGENT TANK must be HYDROSTATICALLY TESTED, and the FIRE EXTINGUISHING AGENT must be REPLACED in accordance with the maintenance schedule published in ANSUL® R-102 SYSTEM (STANDARD UL 300 LISTED). This maintenance to be performed by qualified Ansul® service personnel only.

Inspection shall be conducted on a monthly basis in accordance with the manufacturer's Operation Manual. At a minimum, this inspection shall include verification of the following:

WELLS BLOOMFIELD, LLC
VENTILATOR HOOD OWNERS MONTHLY INSPECTION LOG

OPERATION	AGENT DATE												
Extinguishing system components: In proper place and (visually in good order													
Manual pull station actuators for fire suppression system are obstructed													
The maintenance log is in place and up to date													
No obvious physical damage or condition exists that might prevent operation of the fire suppression system													
The nozzle blow-off caps are in place and in good condition													
The hood, duct and protection cooking appliance have not been replaced, modified or relocated													
Clean plenum GREASE BAFFLE and BLOWER (max. interval: 3 months)													
Change PRE-FILTER and FILTER PACK (as required)													

IL2144

This MAINTENANCE LOG is to be performed and completed by a trained technician who has completed the instruction necessary to perform the maintenance and recharge service.

WELLS BLOOMFIELD, LLC
VENTILATOR HOOD MAINTENANCE LOG

OPERATION	AGENT / DATE												
Clean and inspect discharge nozzle in plenum BEFORE filters MAX. interval: 6 months													
Clean and inspect discharge nozzle in plenum AFTER filters MAX. interval: 6 months													
Inspect fire suppression detectors, all releasing devices for actuation, fire suppressant tank liquid level Max interval: 6 months (discharge of fire suppressant not a part of this test)													
Inspect fire suppression hoses, plumbing and tank for obstructions and any condition such as, but not limited to, corrosion and pitting. Max interval: 6 months													
Inspect and test all filter interlocks Max. interval: 6 months													
Replace fire damper fusible link: rated @ 212°F Max interval: 12 months													
	Log TEMP												
	Log mfg DATE Stamp												

IL2378a

THIS MAINTENANCE LOG MUST BE KEPT IN A PROTECTIVE COVER PERMANENTLY ATTACHED TO THE APPLIANCE
Log all repairs and recommendations on reverse side. Any repairs, other than replacement of factory authorized parts, to the fire suppression plumbing system must be subject to hydrostatic pressure testing.

ANSULEX Low pH

QUICK IDENTIFIER (In Plant Common Name)

Manufacturer's Name:	ANSUL INCORPORATED	Emergency Telephone No.:	CHEMTREC (800) 424-9300 or (703) 527-3887
Address:	One Stanton Street, Marinette, WI 54143-2542	Other Information Calls:	(715) 735-7411
Prepared By:	Safety and Health Department	Date Prepared:	February 1, 1999

SECTION 1 - IDENTITY

Common Name (Used on Label): (Trade Name and Synonyms)	ANSULEX Low pH Liquid Fire Suppressant	CAS No.:	N/A
Chemical Name:	N/A This is a Mixture	Chemical Family:	Mixture
Formula:	N/A		

SECTION 2 - INGREDIENTS

PART A - HAZARDOUS INGREDIENTS				
Principal Hazardous Component(s) (chemical and common name(s)):	Wt. %	CAS No.	ACGIH TLV	Acute Toxicity Data
None	N/A	N/A	N/A	N/A
PART B - OTHER INGREDIENTS				
Other Component(s) (chemical and common name(s)):	Wt. %	CAS No.	ACGIH TLV	Acute Toxicity Data
Proprietary Mixture of Organic and Inorganic Salts	48.0 - 50.0	N/A	N/E	NDA
Phosphoric Acid	0.2	7664-38-2	N/E	NDA
EDTA	0.65	64--02-8	N/E	NDA
Yellow-Green Fluorescent Dye	0.011	518-47-8	N/E	Oral LD ₅₀ (rat) 6800 mg/kg
Water	Approx. 50.0	7732-18-5	N/E	NDA

SECTION 3 - PHYSICAL AND CHEMICAL CHARACTERISTICS (Fire and Explosion Data)

Boiling Point:	113°C	Specific Gravity (H ₂ O=1):	1.33	Vapor Pressure (mm Hg):	Not Determined
Percent Volatile by Volume (%):	Approx. 50.0	Vapor Density: (Air = 1):	1.03	Evaporation Rate: (Butyl Acetate=1):	Approx. 0.005
Solubility in Water:	100%	Reactivity in Water:	Mild exothermic reaction		
Appearance and Odor:	Fluorescent Yellow Colored Liquid, Mild Odor				
Flash Point:	None to boiling	Flammable Limits in Air % by Volume:	N/A	Extinguisher Media:	N/A
Auto-Ignition Temperature:	N/A				
Special Fire Fighting Procedures:	NONE - THIS IS AN EXTINGUISHING AGENT				
Unusual Fire and Explosion Hazards:	None				

SECTION 4 - PHYSICAL HAZARDS

Stability:	Unstable <input type="checkbox"/> Stable <input checked="" type="checkbox"/>	Conditions to Avoid:	N/A
Incompatibility (Materials to Avoid):	Reactive Metals, ClF ₃ , electrically energized equipment, any material reactive with water.		
Hazardous Decomposition Products:	Not established, acrid fumes.		
Hazardous Polymerization:	May Occur <input type="checkbox"/> Will Not Occur <input checked="" type="checkbox"/>	Conditions to Avoid:	N/A

M522 p/n 2M-Z16247 OpM WVU- Universal Hood

SECTION 5 - HEALTH HAZARDS

ANSULEX Low pH (continued)

Threshold Limit Value:	None Established		
Routes of Entry: Eye Contact:	Irritant		
Skin Contact:	Irritant		
Inhalation:	Not an expected route of entry. Can be irritating to mucous membranes.		
Ingestion:	Irritating to mucous membranes. Acute Oral LD ₅₀ (Sprague-Dawley rats) 825.5mg/kg.		
Signs and Symptoms:	Acute Exposure: Material irritates skin, eyes, and mucous membranes. Chronic Exposure: None known.		
Medical Conditions Generally Aggravated by Exposure:	None known.		
Chemical Listed as Carcinogen or Potential:	National Toxicology Program: Yes <input type="checkbox"/> No <input checked="" type="checkbox"/>	I.A.R.C Monographs: Yes <input type="checkbox"/> No <input checked="" type="checkbox"/>	OSHA Yes <input type="checkbox"/> No <input checked="" type="checkbox"/>

SECTION 6 - EMERGENCY AND FIRST AID PROCEDURES

Eye Contact:	Flush and irrigate with water for 15 minutes while holding eyelids open. If irritation persists, seek medical attention.
Skin Contact:	Wash thoroughly with soap and water. If irritation persists, seek medical attention.
Inhalation:	Fresh air if symptoms occur. If irritation persists, seek medical attention.
Ingestion:	Dilute by drinking large quantities of water.

SECTION 7 - SPECIAL PROTECTION INFORMATION

Respiratory Protection (Specify Type):	N/A		
Ventilation:	Local Exhaust: N/A	Mechanical (General):	N/A
Protective Gloves:	Rubber gloves for spill/leak	Eye Protection:	Chemical goggles recommended during spill/leak procedures.
Other Protective Clothing or Equipment:	Eye wash and safety showers are good safety practice.		

SECTION 8 - SPECIAL PRECAUTIONS AND SPILL/LEAK PROCEDURES

Precautions to be taken in Handling and Storage:	Store in original container. Keep tightly closed. Keep separate from acid.
Other Precautions:	See incompatibility information in Section 4.
Steps to be taken in Case Material is Released or Spilled:	Stop leaks. Contain spills. Remove as much as possible. Place in closed container for proper disposal Wash spill area with large amounts of water to remove traces and neutralize.
Waste Disposal Methods:	Dispose of in compliance with local, state and federal regulations.

HAZARDOUS MATERIAL IDENTIFICATION SYSTEM

HAZARD INDEX	
4 SEVERE HAZARD	0 HEALTH
3 SERIOUS HAZARD	0 FLAMMABILITY
2 MODERATE HAZARD	0 REACTIVITY
1 SLIGHT HAZARD	
0 MINIMAL HAZARD	

N/A = Not Applicable NDA = No Data Available N/E = Not Established

ANSUL and ANSULEX are registered trademarks.

Internet Address: <http://www.ansul.com>

ANSUL INCORPORATED, ONE STANTON STREET, MARINETTE, WI 54143-2542

Form No. F-90160-6

©1999 Ansul Incorporated

M522 p/n 2M-Z16247 Opm WVU- Universal Hood

TROUBLESHOOTING SUGGESTIONS

Problem	Possible Cause	Suggested Remedy
Unit will not operate (no indicators lights lit)	Disconnected from electric power	Reconnect to electric power
		Reset circuit breaker for unit
Unit will not operate (buzzer sounds)	Fire suppression system not set	Contact an authorized Ansul® distributor for repairs
CHECK FILTER light lit	Filter pack, Pre-filter or baffle filter not in position	Properly install filters
REPLACE FILTER light lit	Filter nearing end of service life	Arrange to replace filters in a timely manner
	Filter pack plugged	Replace filter pack
	Fire damper in exhaust collar has closed	Contact an authorized Wells service agent for repairs
SERVICE REQUIRED light lit (cooking appliance not operating)	One or more vacuum sensing lines or ports plugged, or sensing line dislodged.	Contact an authorized Wells service agent for repairs
	NOTE: If, after 20 seconds, there is insufficient airflow for proper operation, SERVICE REQUIRED light will illuminate and under-hood appliance (s) will be de-energized.	
	Press VENTILATOR POWER SWITCH to OFF, then back to ON to reset system.	

NOTE:

FILTERS are the only user serviceable components in this ventilator hood system. For all problems that cannot be remedied by servicing the filters, contact:

- Ventilator section - authorized Wells service agency
- Fire suppression system - authorized Ansul® distributor

IMPORTANT:

Contact ANSUL® for fire suppression system installation, set-up and service:

Ansul Incorporated 1-800-TO-ANSUL (1-800-862-6785)
 One Station Street
 Marinette, WI 54143-2542 website <http://www.ansul.com>

IMPORTANT:

Parts used in the Ansul® fire suppression system are not serviceable by the owner/operator.

Procedures for servicing fire suppression equipment are described in:

ANSUL® R-102 SYSTEM DESIGN, INSTALLATION, RECHARGE AND MAINTENANCE MANUAL
 (418087, current edition)

NOTE:

ANSUL® Manual 418087 is intended for use by authorized Ansul® service personnel only.

WIRING DIAGRAM

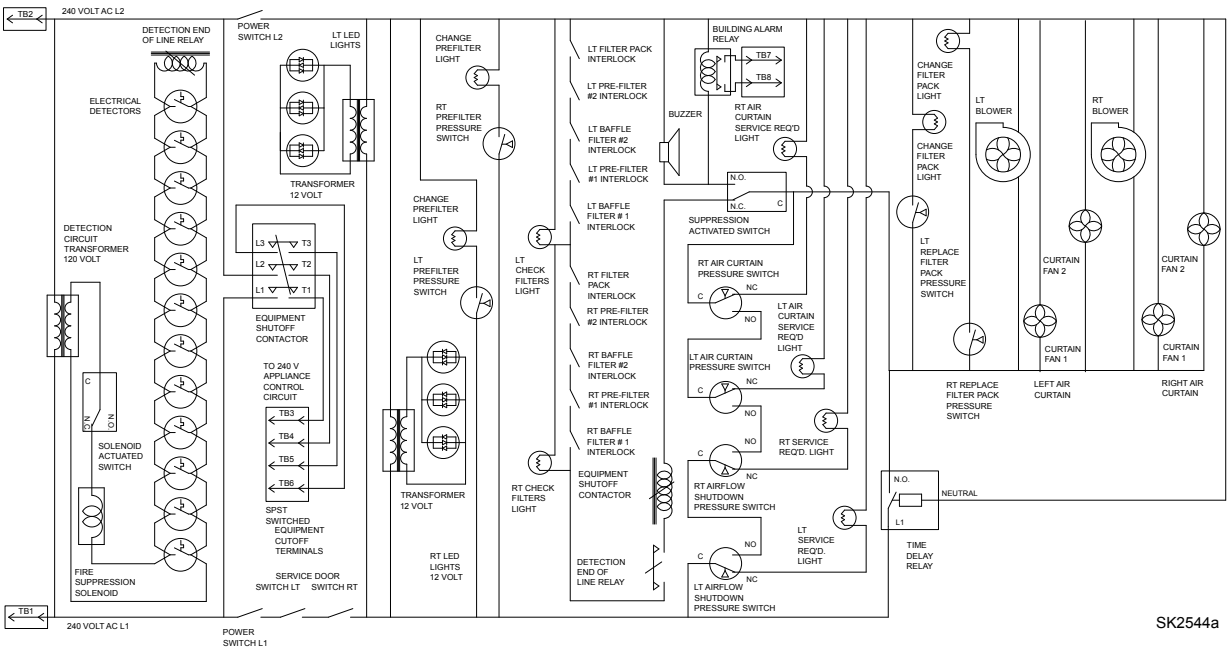
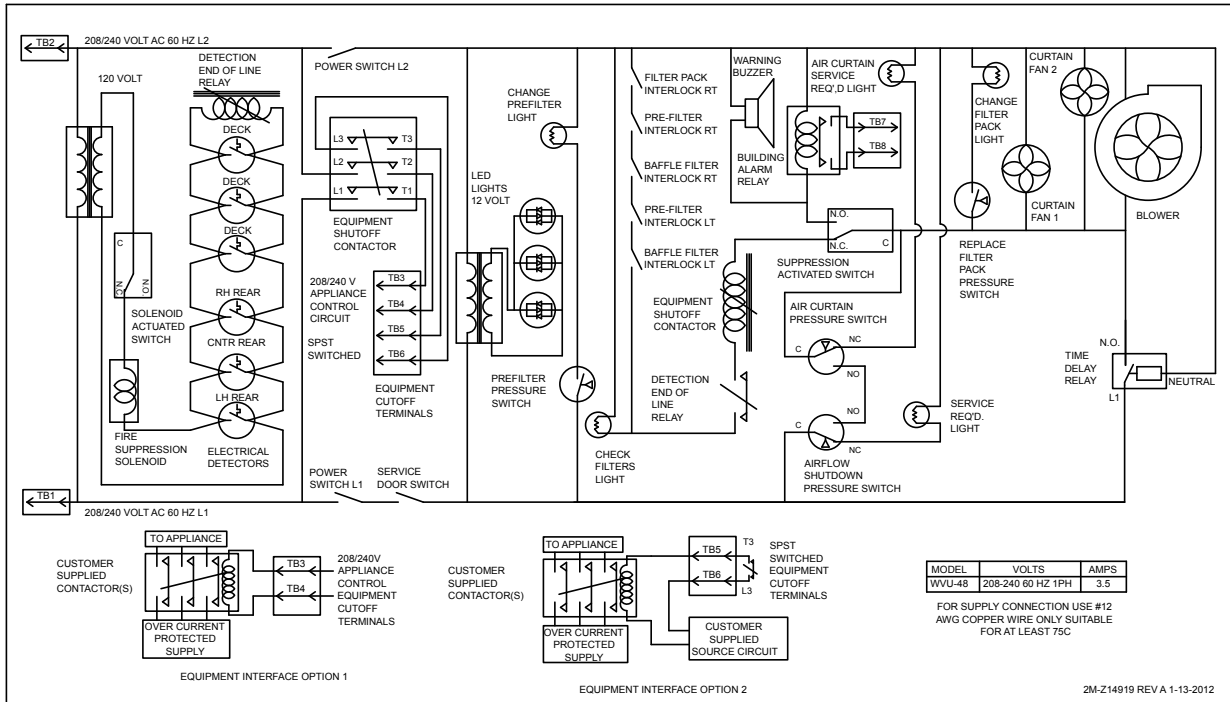

M522 p/n 2M-Z16247 OpM WVU- Universal Hood

EXPLODED VIEW & PARTS LIST

Filter Maintenance

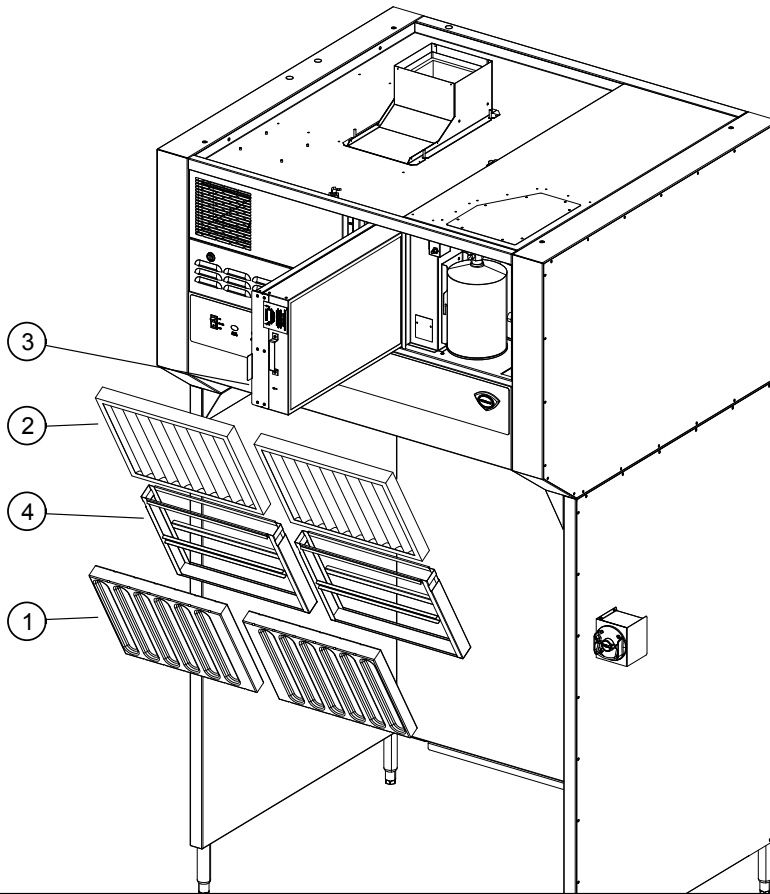

<p>①</p> <p>Baffle Filter: 16" x 20" Part No: 2I-Z14670</p>	<p>②</p> <p>Pre-Filter Hood Part No: 2I-Z16258</p>
<p>③</p> <p>Filter HEPA/Carbon Pack Part No: N1-WL0171</p>	<p>④</p> <p>Pre-Filter Cage Part No: M3-WL0230</p>

Model: WVU48 Filter Assy

SK2553 Rev. D, 10/20/2015

M522 p/n 2M-Z16247 OpM WVU- Universal Hood

EXPLODED VIEW & PARTS LIST

Filter Maintenance

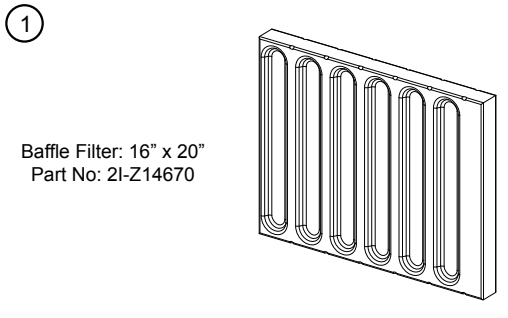
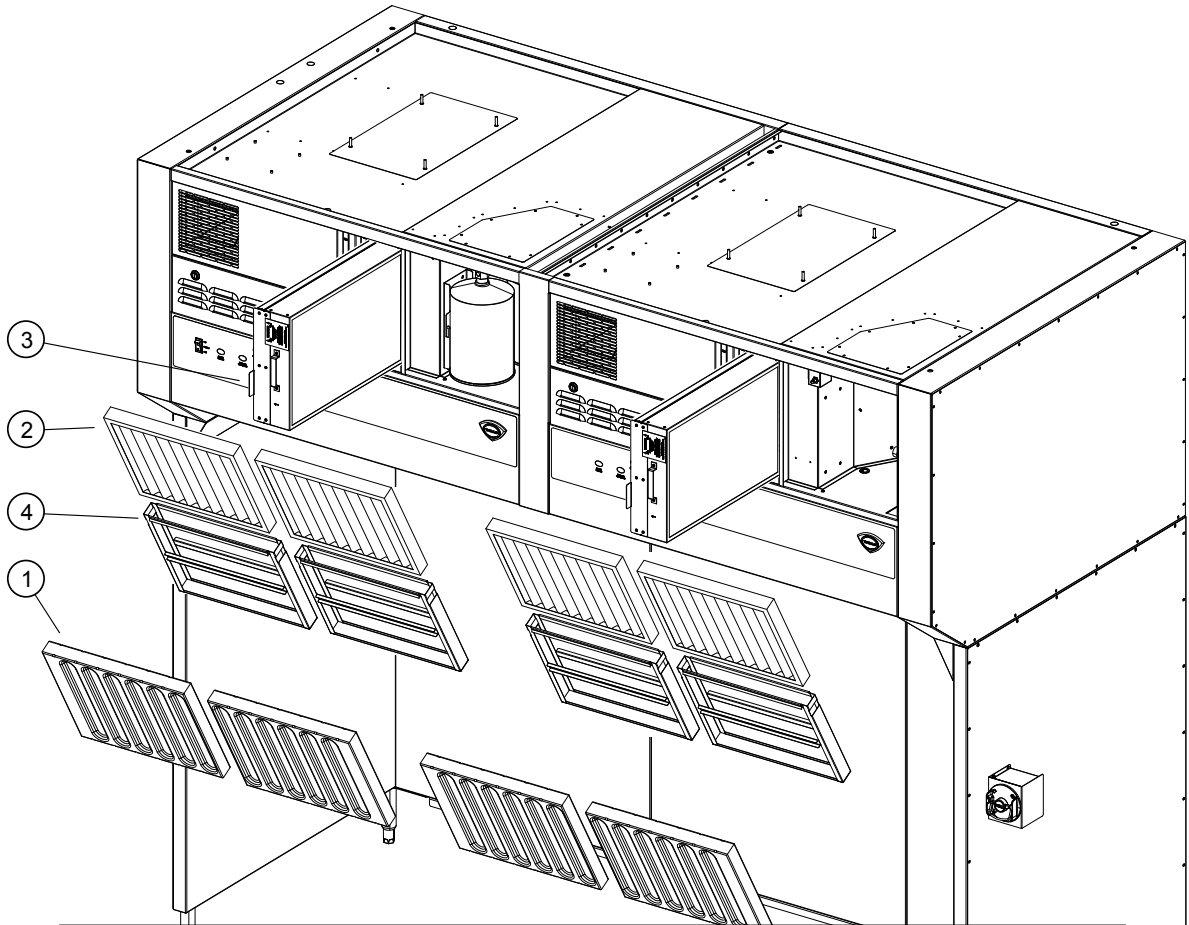

①

Baffle Filter: 16" x 20"
Part No: 2I-Z14670

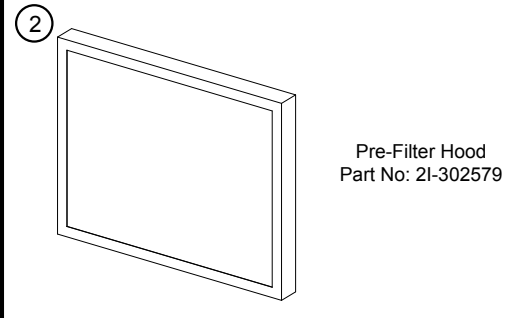

②

Pre-Filter Hood
Part No: 2I-302579

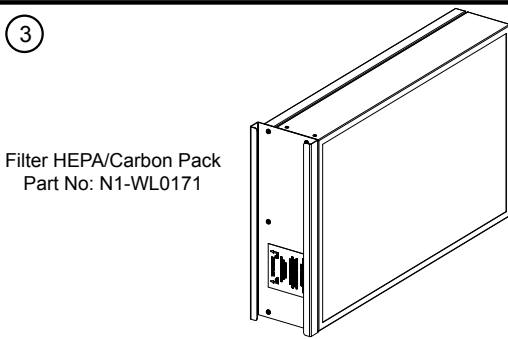

③

Filter HEPA/Carbon Pack
Part No: N1-WL0171

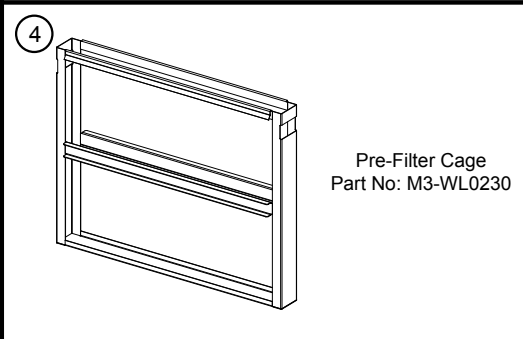

④

Pre-Filter Cage
Part No: M3-WL0230

Model: WVU96 Filter Assy

SK2576 Rev. C, 10/20/2015

M522 p/n 2M-Z16247 OpM WVU- Universal Hood

EXPLODED VIEW

Universal Hood Internal Control

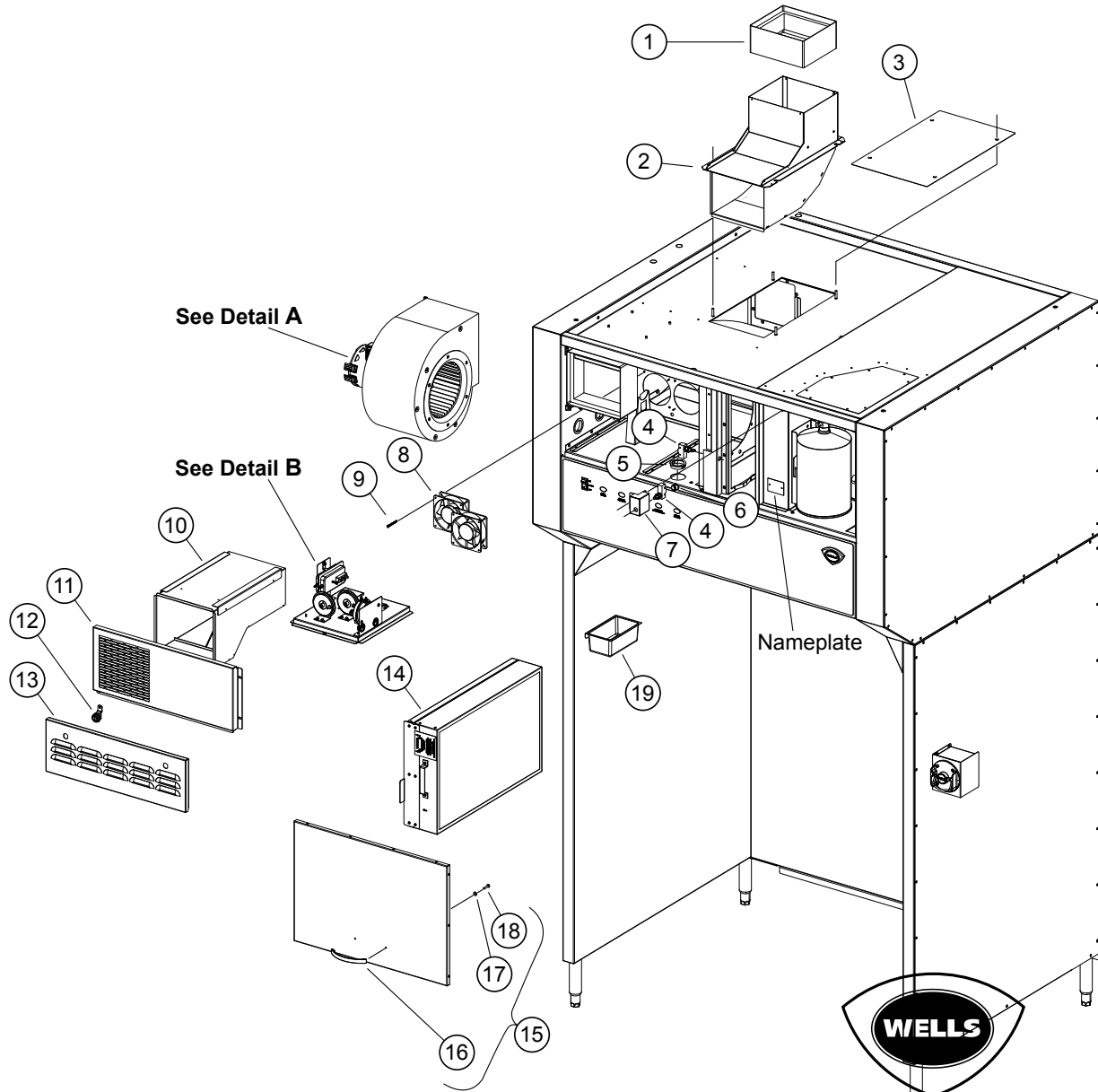

Model: WVU48 Universal Hood Internal Control

SK2554 Rev. A 2/13/2015

PARTS LIST

Universal Hood Internal Control

Internal Control Assy				
Fig No.	Part No	WVU48	WVU96	Description
1	2V-307913	1	2	DAMPER FIRE 8X9 WVU
2	N1-WL0244	1	2	TOP DISCHARGE SCOOP ASSY.
3	N1-Z14139	1	2	BLOCK-OFF PLATE, TOP DISCHARGE
4	2E-300407	6	12	SWITCH MANUAL ADVANCE ROT
5	2K-Y8571	3	7	BUSHING SNAP 2 1/8
6	2K-Y1139	1	2	BUSHING HEYCO SB500-6
7	N1-Z14484	1	2	MOUNTING BRACKET, DOOR
8	2U-200577	2	4	MOTOR, FAN 240V, HI-OUTPU
9	2C-45201	4	8	SCREW 8-32X2 PH PAN HD MS
10	N1-WL0172	1	2	DUCTWORK ASSEMBLY
11	N1-Z14097	1	2	FRONT DISCHARGE VENTPANEL
12	2R-Z14532	2	4	CAM LATCH, SLOTTED
13	N1-Z14087	1	2	ACCESS DOOR, ELECT
14	N1-WL0171	1	2	FILTER HEPA/CARBON PACK
15	N1-WL0170	1	2	DOOR ASSY,FRONT ANSUL
16	2R-Z14429	1	2	HANDLE, 5"
17	2C-1810	2	4	WASHER 3/16 BURR STL NP
18	Included with #15	2		
19	2D-Z14672	1	2	GREASE CUP

EXPLODED VIEW & PARTS LIST

Universal Hood Internal Control (Detail A)

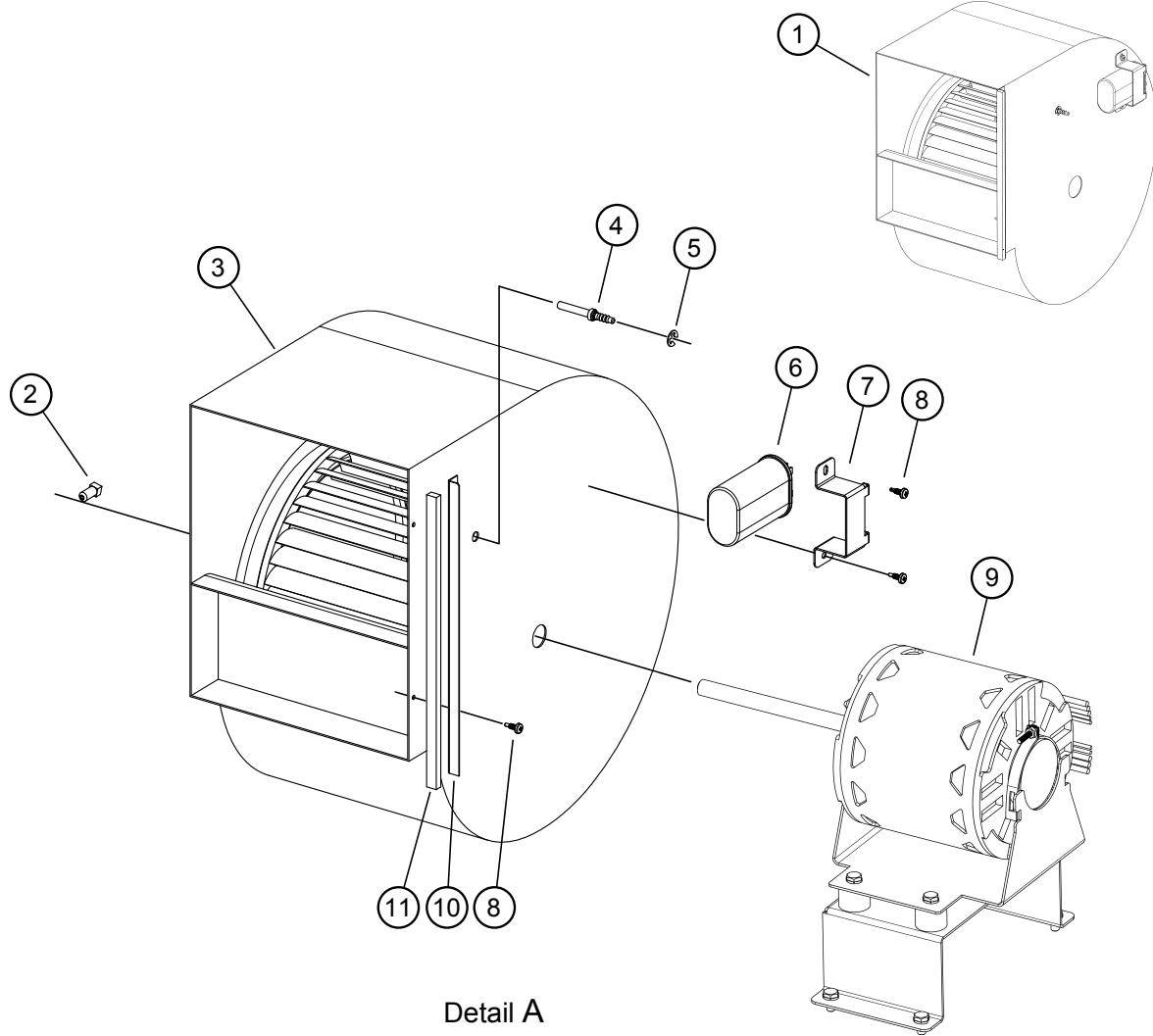

Detail A
Blower & Motor Assy

08/2017 MODELS AND LATER*

DETAIL A, Blower & Motor Assy

Fig No.	Part No	WVU48	WVU96	Description
1	NI-WL0830	1	2	BLOWER ASSEMBLY
2	Included w/ no 4	1	2	
3	2U-Z14912	1	2	BLOWER & WHEEL ASSY
4	2A-Z15331	1	2	PRESSURE TAP TUBE FITTING
5	2C-Z15332	1	2	E-CLIP RETAINING RING 1/4"
6	2E-Z14913	1	2	RUN CAPACITOR, 10MFD, 370V
7	N1-Z15392	1	2	BRACKET, RUN CAPACITOR
8	2C-301522	4	8	SCREW 8X12 RPH PAN SELF DRILLING
9	NI-WL0831	1	2	BLOWER MOTOR ASSEMBLY
10	N1-Z15316	1	2	SIDE FLANGE, BLOWER HOUSING
11	N1-Z15317-1	1	2	GASKET TAPE 10.25 LG, BLOWER SIDE FLANGE

EXPLODED VIEW & PARTS LIST

Universal Hood Internal Control (Detail B)

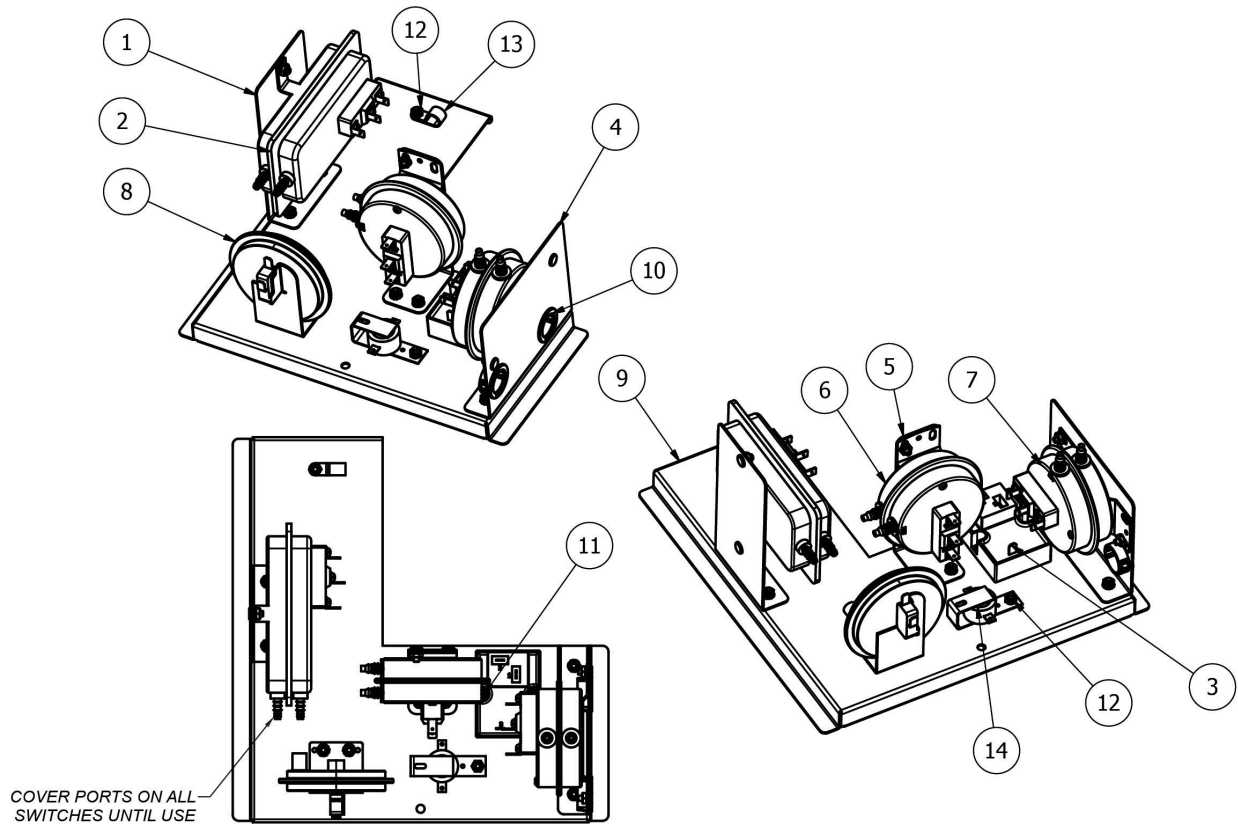

08/2017 MODELS AND LATER*

DETAIL B, Internal Control Panel Assy

Fig No	Part Number	WVU48	WVU96	Description
1	N1-Z15362	1	2	BRACKET, PRESSURE SWITCH
2	2E-Z14673	1	2	PRESSURE SWITCH
3	2P-Z17415		1	TIMER,CUBE/ RELAY
4	N1-Z14886	1	2	BRACKET,PRESSURE SWITCH
5	N1-Z15531	1	2	BRACKET,HEPA PRESS.SWITCH
6	2E-Z15352	1	2	VACUUM SWITCH,HEPA FILTER
7	2E-Z15365	1	2	PRESSURE SWITCH
8	2E-302591	1	2	SWITCH VACUUM #2
9	N1-Z22130	1	2	MOUNTING TRAY, INTERNAL CONTROLS
10	2K-Y5093	2	4	BUSHING-SNAP #SB-1000-12
11	2C-08-07-0042		2	SCREW 8-32X5/8 RHP STL NP
12	2C-Z7165	15	30	NUT 8-32 HEX SS W/EXT WSH
13	2C-Z18059	1	2	CABLE CLAMP, 0.5 INCH NYLON
14	2J-44834		1	BUZZER

EXPLODED VIEW

Universal Hood Electrical Components

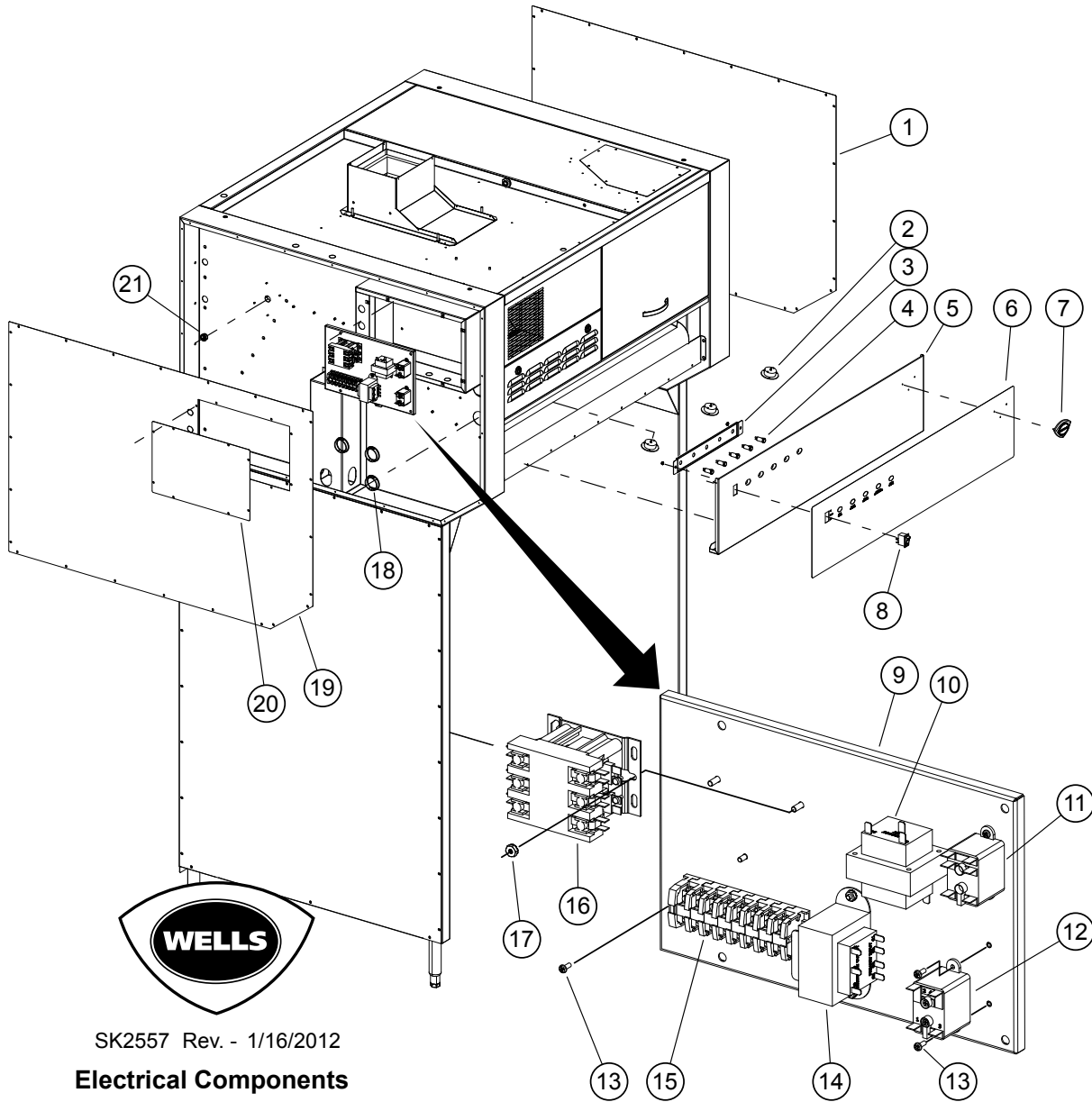

SK2557 Rev. - 1/16/2012
Electrical Components

PARTS LIST

Universal Hood Electrical Components

Control Panel				
Fig No.	Part No	WVU48	WVU96	Description
1	N1-Z14142	1		COVER, HOOD SIDE RIGHT
2	N1-WL0245	3	6	LED FLOODLIGHT, 45W CW w/TERM
3	N1-Z15418	1	2	MOUNTING PLATE, CTRL LIGHT
4	N1-WL0281	5	10	LIGHT SIGNAL, CLEAR LED w/TERM
5	N1-WL0250	1		CONTROL PANEL, FRONT ASSY
5	N1-WL0278		1	CONTROL PANEL, FRONT ASSY
6	2M-Z14069		1	GRAPHIC PANEL, NO SWITCH
6	2M-Z14510	1		GRAPHIC PANEL W/ SWITCH
7	2M-306719	1	2	LOGO WELLS DIECAST SHIELD
8	2E-305295	1		SWITCH ROCKER 250V 10A GR
9	N1-Z15435	1		ELEC. AUTOMAN BKT. MODIFY
10	2E-Z15018	1	2	TRANSFORMER, 208/240 12V
11	2E-44514	1		RELAY 208-240V COIL
12	2E-Z15353	1		RELAY, 120V COIL, SPNO
13	2C-1488	6		SCREW 6-32X3/8 RHP STL NP
14	2E-Z15335	1		TRANSFORMER, 208/240
15	WS-WL0282	1		TERMINAL BLOCK ASSY
16	2E-Z14960	1		CONTACTOR, 40A
17	2C-40680	2		NUT 10-32 HEX KEPS MS SS
18	2K-Y8571	3	7	BUSHING SNAP 2 1/8
19	N1-Z14141	1		COVER, HOOD SIDE LEFT
20	N1-Z15344	1		COVER,SIDE ELECTRIC BOX
21	2K-8043	2		BUSHING HEYCO SB-875-10

EXPLODED VIEW & PARTS LIST

Universal Hood Suppression System

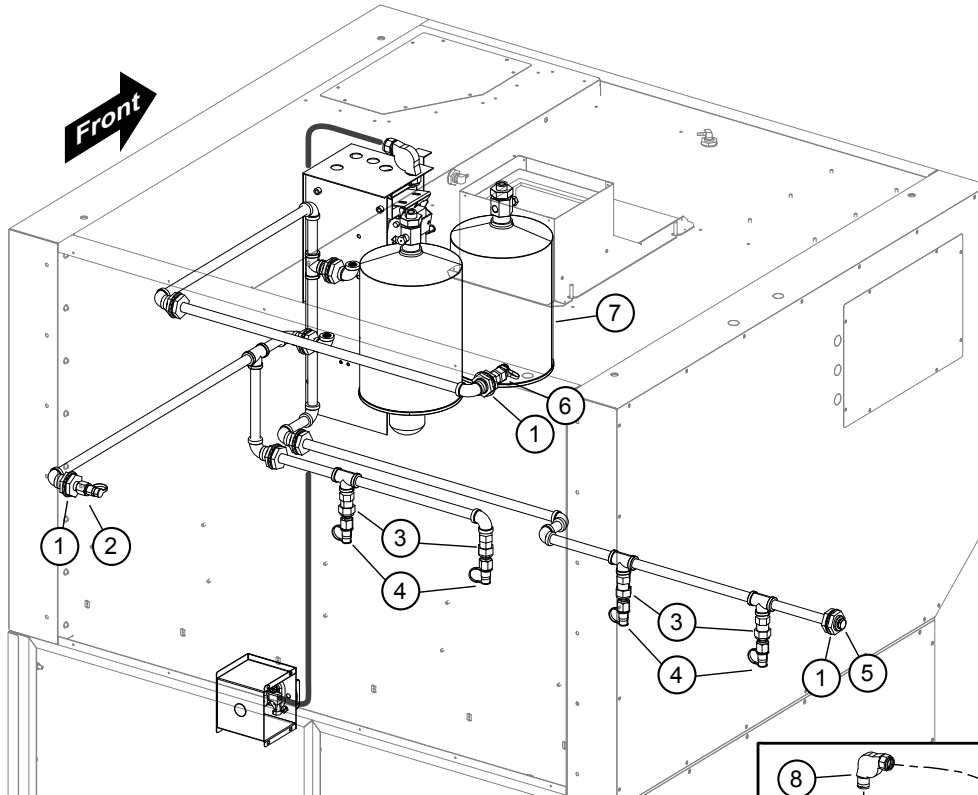

Suppression System				
Fig. No	Part No	WVU48	WVU96	Description
1	2K-47269	8	16	ADAPTER 3/8IN QUICK CON A
2	2O-47267	1	2	NOZZLE ANSUL 1N
3	2O-307481	5	10	ADAPTER SWIVEL ANSUL
4	2O-Z14574	4	8	NOZZLE, #245
5	2C-Z15115	1	2	HEX HEAD PIPE PLUG 3/8NPT
6	2O-302931	1	2	NOZZLE 1 W
7	2O-304433	2	4	TANK SS ANSULEX 1.5 GALLO
8	2O-47272		1	PULLEY ELBOW
9	N1-Z15435	1	1	ELEC. AUTOMAN BKT MODIFY
10	2O-Z14918	1	2	ANSUL CARTRIDGE LT-30-R
11	2O-308131		1	REMOTE PULL STATION RED
12	2O-307966	-	1	ANSUL REG. ACTUATOR ASSY
13	2K-Z15635	-	1	ELBOW, MALE 7/16-20X1/4NPT

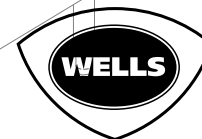
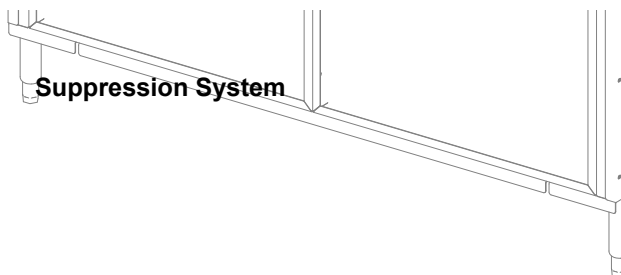
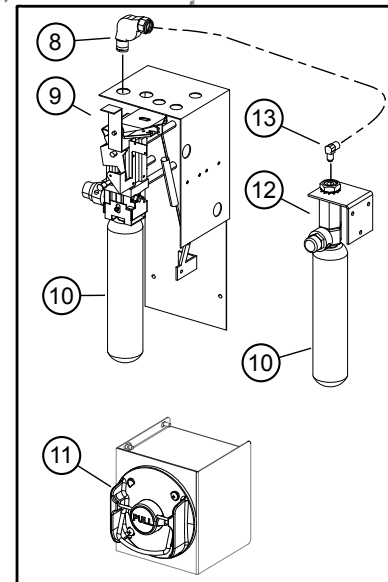

SK2558 Rev. A 1/16/2015

EXPLODED VIEW & PARTS LIST

Universal Hood Detection System

Adapter 1/2" Quick Seal
Part No: 2T-Z15320

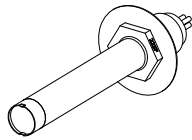
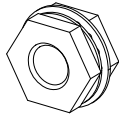

Thermal Detector-225°F
Part No: 2T-Z15320

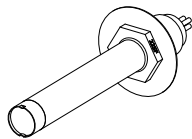

Thermal Detector-275°F
Part No: 2T-Z16137

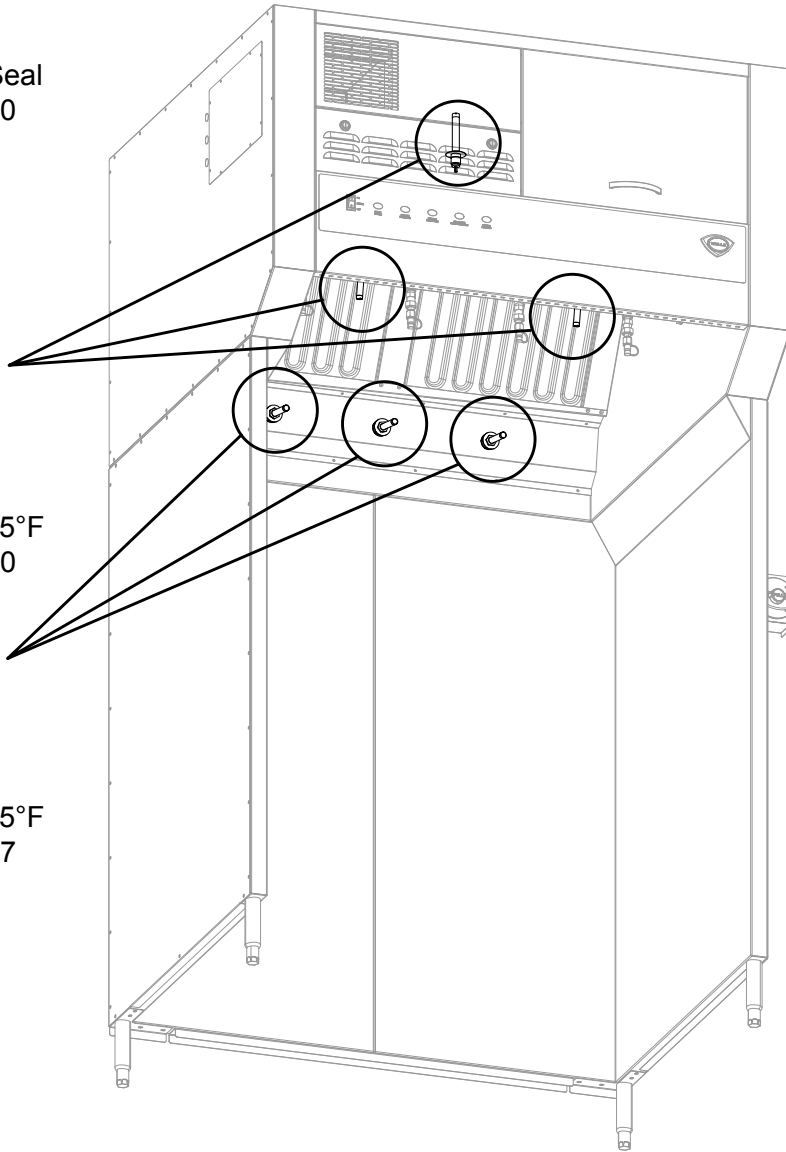

Detection System

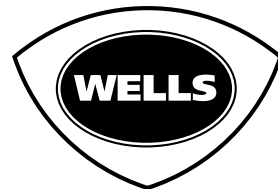

SK2559 Rev. A 7/25/2012

EXPLODED VIEW & PARTS LIST

Universal Hood Base Assy

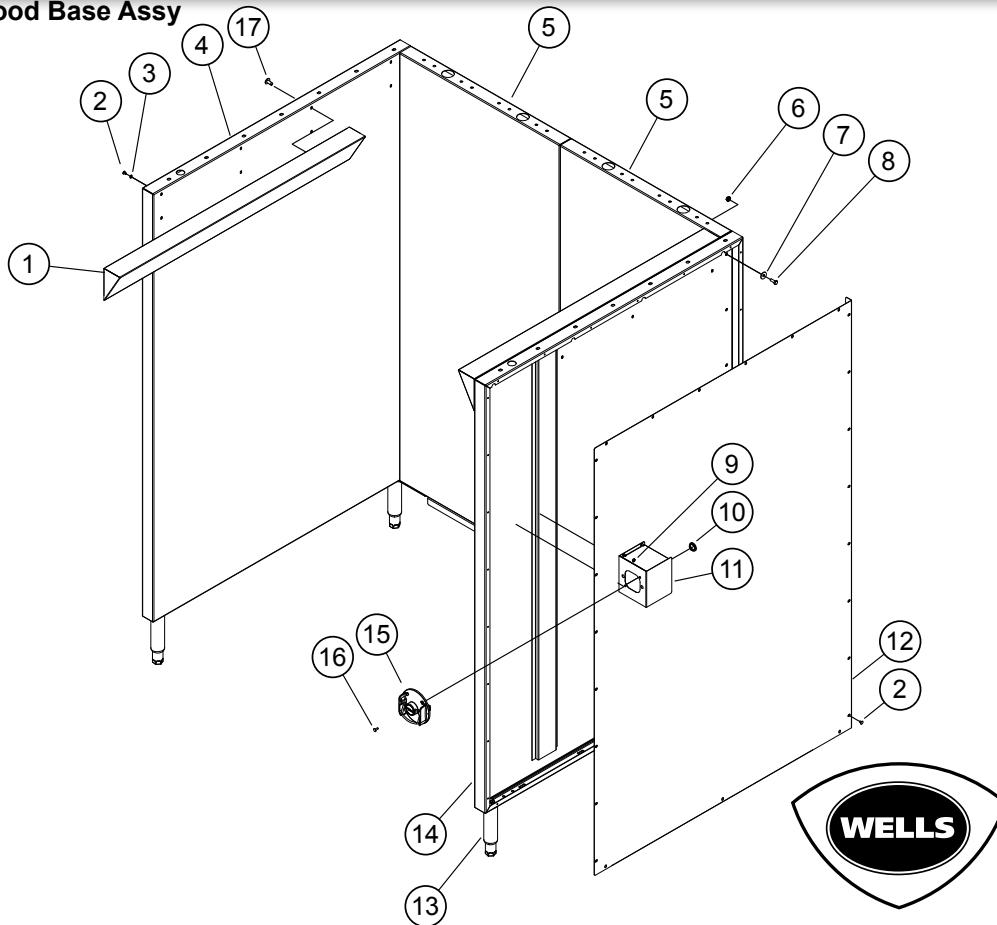

Model: WVU48 Base Assy

SK2561 Rev. A 11/18/2013

Base Assembly				
Fig No.	Part No	WVU48	WVU96	Description
1	N1-Z15193		2	BASE DEFLECTOR
2	2C-35487		66	SCREW 8-32X5/16 PH TR HD
3	2C-1825		16	WASHER #8 EXT STL NP
4	N1-WL0176		1	BASE,SUPPORT ASSY LFT
5	N1-Z16772	2		BASE,BACK SUPPORT
	N1-Z16774		3	BASE,BACK SUPPORT 8FT
6	2C-6517	70	85	NUT 1/4-20 HEX STL NP
7	2C-A27469	70	85	WASHER,FLAT 1/4IN 7/8OD 1
8	2C-Z5555	70	85	BOLT 1/4-20 X .75 HEX SS
9	2C-31053		4	NUT 8-32 KEPS MS NICKEL
10	2P-70903-05		1	PLG BTN PLTD MTL 7/8
11	N1-WL0126		1	BOX, MANUAL PULL ASSEMBLY
12	N1-WL0180		1	COVER,BASE SIDE RT ASSY
	N1-Z14152		1	COVER, BASE SIDE LEFT
13	2A-307628		4	LEG 6 ADJ 1/2-13 SS
	2A-Z16259			LEG, 10" ADJ. 1/2-13 SS (Optional)
14	N1-WL0177		1	BASE,SUPPORT ASSY RT
15	2O-308131		1	REMOTE PULL STATION RED
16	2C-31730		2	SCREW 8-32X1/2 PH TR HD M
17	2C-6349		16	SCREW #8X3/8 B THP STL NP

PARTS & SERVICE

DESCRIPTION

PART NO.

IMPORTANT: Use only factory authorized service parts and replacement filters.

For factory authorized service, or to order factory authorized replacement parts, contact your Wells authorized service agency, or call:

Wells Manufacturing
265 Hobson Street
Smithville, Tennessee 37166 U.S.A.

Service Dept.
phone: (314) 678-6314
fax: (314) 781-2714

Service Parts Department can supply you with the name and telephone number of the WELLS authorized service agency nearest you.

CUSTOMER SERVICE DATA

please have this information available if calling for service

RESTAURANT _____ LOCATION _____

INSTALLATION DATE _____ TECHNICIAN _____

SERVICE COMPANY _____

ADDRESS _____ STATE _____ ZIP _____

TELEPHONE NUMBER (____) _____ - _____

EQUIPMENT MODEL NO. _____ EQUIPMENT SERIAL NO. _____

VOLTAGE: (check one) 208 240



SERVICE TRAINING - QUALITY SERVICE



CUSTOMER SATISFACTION



WELLS MANUFACTURING

265 Hobson Street, Smithville, Tennessee 37166

telephone: 314-678-6314

fax: 314-781-2714

www.wells-mfg.com