

Series Includes:

CAT507

CAT509

CAT522

CAT529

CAT529-BD

CAT529-BDR



welcome

Thank you for your purchase of a Winston CVap® Thermalizer. The benefits you will enjoy from this cabinet include precise doneness temperatures, greater yields, safer foods, reduced labor, and superior food quality.

capable of producing foods at the precise temperature and moist or crisp texture desired.

If you have any questions, or if anything cooked in your CVap Thermalizer doesn't meet your satisfaction, please call our Customer Service Center at 1.800.234.5286, or email us at customerservice@winstonind.com.

This cabinet utilizes Controlled Vapor Technology (CVap). Using a combination of dry and moist heat, CVap cabinets are

table of contents

welcome	2	daily operating procedures	10-14
safety	3	retherm guidelines	15
receiving your cabinet	4	retherm guidelines (blank).....	16
installing auto water fill	5	roasting guidelines	17
electrical information	6	daily cleaning.....	18-19
ventilation requirements	7	troubleshooting	20-22
component identification.....	8	warranty & terms & conditions	23
controls.....	9		

Please read this entire use & care manual before operating your CVap therm & hold cabinet. The manual contains important safety information and operating instructions.

As is the case with most cooking appliances, your CVap cabinet should be used with caution. Please read the following warnings to avoid potential injuries.

Need to contact us? Choose the most convenient method.

Internet: www.winstonfoodservice.com
Email: customerservice@winstonind.com
Phone: 1.800.234.5286 | 1.502.495.5400 | 1.502.495.5458
Mail: 2345 Carton Drive | Louisville, KY 40299 USA

Copyright© 2020 Winston Industries LLC. All rights reserved. CVap is a registered trademark of Winston Industries LLC. The CVap logo is a trademark of Winston Industries LLC. All other company and product names may be trademarks of their respective companies.

⚠ DANGER

Electrical Hazard

Can cause serious injury or death. Do not attempt to install or service this equipment unless you are a licensed electrician or trained servicer.

1. Because this equipment utilizes high voltage, it should only be installed and serviced by a licensed electrician or trained servicer. Attempting to install or service the equipment yourself could result in serious, potentially fatal injuries.
2. If an electrical shock is felt when touching equipment, shut off power immediately (unplug cord or turn off circuit breaker) and call a trained servicer for repair. Failure to do so could result in serious, potentially fatal injuries.
3. Always turn power switch off any time equipment is not in use.

⚠ WARNING

Burn Hazard

Can cause serious injury. Avoid heated vapor when opening or closing equipment door.

4. This unit utilizes heated water vapor, which transfers heat much more quickly and efficiently than dry air of the same temperature. Use caution when opening doors or reaching into the unit, as heated vapor can quickly cause burns.

⚠ WARNING

Contamination Hazard

Can cause serious illness or damage to equipment. Clean equipment daily to avoid potential contamination hazard.

5. Clean equipment daily to prevent food residue or chlorides (salts) from accumulating, which can damage stainless steel and contaminate food. **Failing to follow proper cleaning procedures can void your warranty.**

6. Prior to using equipment for the first time, perform the daily cleaning procedure found on pages 18 and 19.

⚠ CAUTION

Burn Hazard

Can cause injury. Allow 30 minutes for equipment to cool before attempting to clean.

7. Always allow equipment to cool before cleaning.

⚠ CAUTION

High Temperature and Grease Hazard

Can cause damage to equipment. Avoid placing equipment near high heat or in grease laden atmosphere.

Don't place equipment in an area where air temperatures exceed 100°F (38°C). A heat shield may be required to prevent heat exposure and grease laden vapors from affecting the equipment. Excess heat and grease inside the equipment cavities can cause electrical components to fail.

⚠ WARNING

Safety Hazard, Intended Use

Can cause serious injury or damage to equipment >> Supervise untrained, young, or handicapped persons.

1. This equipment is not intended for use by persons (including children) with reduced physical, sensory, or mental capabilities, or lack of experience and knowledge, unless they have been given supervision or instruction concerning use of the equipment by a person responsible for their safety.
2. Children should be supervised to ensure that they do not play with the equipment.
3. This equipment is intended to be used for commercial applications, for example in kitchens of restaurants, canteens, hospitals and in commercial enterprises such as bakeries, butcheries, etc., but not for continuous mass production of food.

receiving your cabinet

Shipping Damage

Examine equipment thoroughly for shipping damage before, during and after unloading. All Winston products are carefully inspected and verified to be in good condition before leaving our factory. The carrier delivering your cabinet has assumed responsibility for its safe arrival. If you notice any damage (obvious or hidden), a claim must be made to the carrier.

Obvious Loss or Damage

Please note any obvious loss or damage on the freight bill or express receipt, and have the carrier's agent sign to acknowledge the claim. The carrier will supply the necessary forms. If you do not obtain and complete the forms before the carrier's agent departs, the carrier might refuse your damage claim.

Concealed Loss or Damage

Sometimes loss or damage is not obvious until the product has been unpacked. If you notice damage that was concealed by packaging or crating, contact the carrier in writing to notify them of the damage. The carrier should agree to inspect the damage within 15 days. Please retain all packing materials. The carrier will supply an inspection report and the required claim forms.

Physical

Casters are non-marking; back casters are non-locking, front are locking.

Water Supply

In order to operate properly, the evaporator in this cabinet must be filled with clean, potable water. Hardware is included to connect the cabinet to a copper line in your facility's water system. If your facility has plastic or galvanized pipes, contact a licensed plumber to connect the water supply. Equipment should be installed to comply with applicable federal, state, or local plumbing codes.

Units with automatic water fill systems are to be installed with adequate backflow protection to comply with federal, state, and local codes.

As water evaporates, any minerals in the water will deposit on the surface of the evaporator. These mineral deposits will inhibit the transfer of heat. Deposits can also degrade and damage stainless steel. The best way to avoid mineral deposits is to clean the unit daily. It is also advisable to contact your water utility for advice on minimizing deposit buildup. Experience has shown that leaks will occur by failing to clean and rinse the evaporator daily. **Leaking evaporators are not covered under warranty.**

installing auto water fill

Insert tubing and push fully into the connector. (Reference drawing on this page.) Once seated, try to pull the tubing out of the connector so that the capture ring comes out (about 1/16" (1.6mm)) and the tubing cannot be removed.

Prior to connecting a newly installed water line to the auto water fill connection, it is extremely important to flush the water line of any debris. Debris in the water line will cause damage to the water solenoid and would not be covered under warranty.

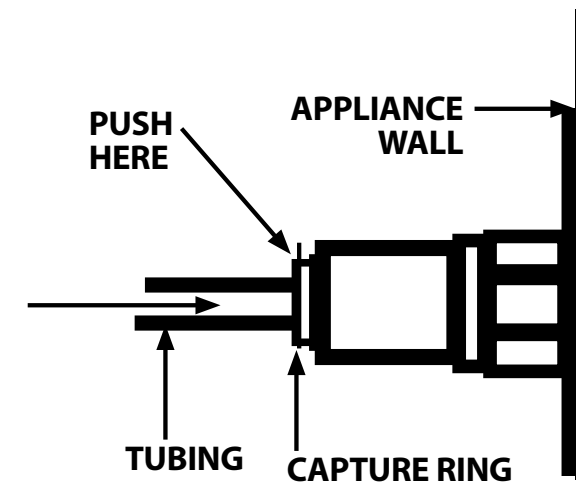

The maximum incoming water temperature may not exceed 140°F (60°C) and the incoming water pressure must be between 20 and 150 psi (1.4 Kg/cm² to 10.5 Kg/cm² (kilogram-force per sq. centimeter)).

CAUTION

High Temperature Hazard

Can cause damage to equipment. Fill evaporator with water prior to turning power on, and do not allow evaporator to run dry.

CAUTION: Units with auto water fill systems MUST NOT BE ALLOWED TO RUN DRY. Heat damage to the water valve may result.

It is the responsibility of the owner and installer to make sure that installation complies with all applicable local and state plumbing codes.

Model	Height with 3" Caster (IN/MM)	Width (IN/MM)	Depth (IN/MM)	Weight (LBS/KG)
CAT507	36.2/919	27.6/701	34.5/876	215/98
CAT509	41.2/1046	27.6/701	34.5/876	235/107
CAT522	76.1/1933 (5" casters)	27.6/701	34.5/876	410/187
CAT529	76.1/1933 (5" casters)	35.5/902	34.5/876	450/203
CAT529-BD	78.7/1998 (5" casters)	35.5/902	34.5/876	560/252
CAT529-BDR	78.7/1998 (5" casters)	35.5/902	34.5/876	560/252

electrical

The equipment is shipped from the factory with a 84" (2134mm) (minimum) power cord and plug. Refer to the table below to determine the correct electrical outlet. It may

be necessary to hire a licensed electrician to install the correct outlet or wiring. Winston does not recommend hard wiring the equipment direct.

Below is electrical information for various models of Winston's CVap therm & hold cabinet.

Model	Volts	Hertz	PH	Amps	Watts	Circuit Amps	Plug Type
CAT507	208	60	1	36.8	7655	50	US/CAN 6-50P
	208	60	3	23.7	7655	30	US/CAN 15-30P
	240	60	1	31.9	7655	50	US/CAN 6-50P
	International						
	230*	50	1	33.3	7655	N/A	N/A
CAT509	208	60	1	36.8	7655	50	US/CAN 6-50P
	208	60	3	23.7	7655	30	US/CAN 15-30P
	240	60	1	31.9	7655	50	US/CAN 6-50P
	International						
	230	50	1	33.3	7655	N/A	N/A
CAT522	208	60	3	33.7	11215	50	US/CAN 15-50P
	240	60	3	29.2	11212	50	US/CAN 15-50P
Not available for the international market at this time.							
CAT529	208	60	3	33.7	11215	50	15-50P
	240	60	3	29.2	11215	50	15-50P
Not available for the international market at this time.							
CAT529-BD & BDR	208	60	3	33.7	11215	50	15-50P
	240	60	3	29.2	11215	50	15-50P
Not available for the international market at this time.							

ventilation requirements

Ventilation clearances - To operate properly, the thermalizer will need sufficient space for air circulation. Allow at least 2" (51mm) clearance on all sides of the cabinet, particularly around ventilation holes. Care should be taken to prevent placing the cabinet close to anything combustible. It must be installed with its supplied legs, feet, or casters. Half size units may be stacked upon each other using only a Winston supplied stacking kit and following the instructions enclosed with the kit. Your warranty may be void if you do not adhere to these ventilation requirements.

⚠ CAUTION

High Temperature and Grease Hazard
Can cause damage to equipment.
Avoid placing equipment near high heat or in grease laden atmosphere.

Do not place equipment in an area where air temperatures around the equipment exceed 100°F (38°C). A heat shield may be required to prevent excessive heat exposure and grease laden vapors from affecting the equipment if adjacent to heat, vapor, or grease generating devices (such as grills, steamers, cabinets, etc.). Excess heat and grease inside the equipment cavities may cause electrical components to fail.

Vent hood - Generally this equipment does not need to be installed under a mechanical ventilation system (vent hood). Check local health and fire codes for specific requirements.

component identification

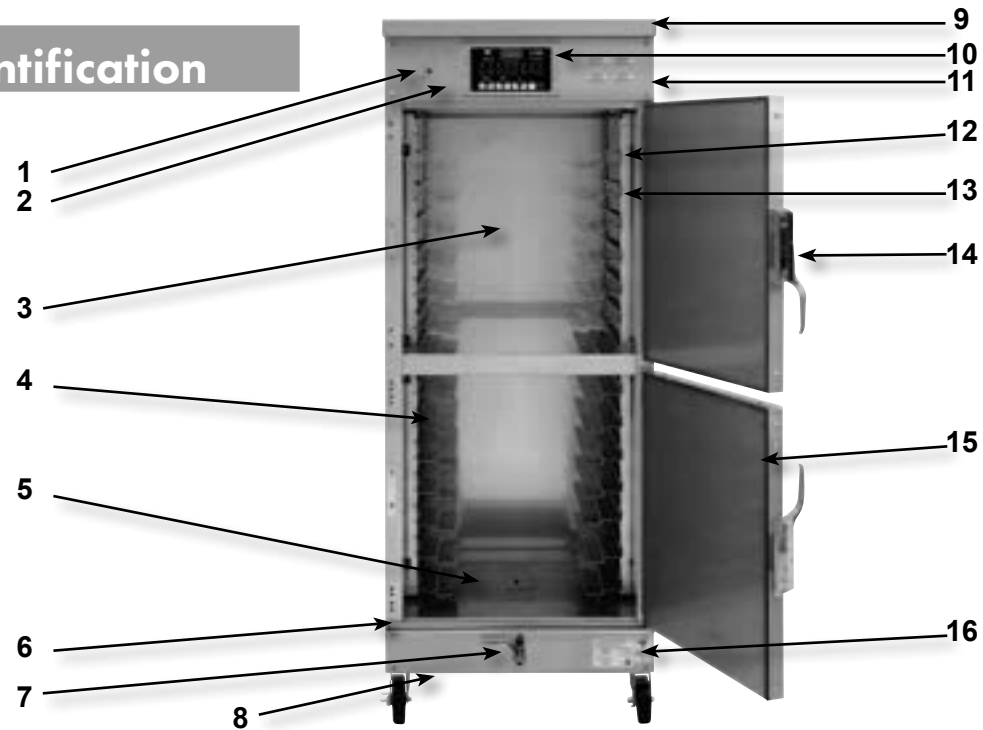

Note: Equipment shown with optional rail supports. Standard unit comes with wire rack supports.

Model shown is CAT522. Highlighted features are common to all models.

1. **Power Switch** allows operator to turn electrical power on and off.
2. **Microprocessor Controller** allows operator to select one of eight multi-interval programmable cycles
3. **Food Chamber** cooking cavity where the dual heat system combines to create the perfect cooking environment.
4. **Adjustable Rack Support** supports racks onto which food is placed.
5. **Evaporator and Heater** (not visible) supply vapor atmosphere to the food chamber by heating water within the evaporator.
6. **Drain Trough** carries water that has condensed onto door back to evaporator.
7. **Drain Valve** enables operator to drain evaporator, to perform daily cleaning.
8. **Bottom Cover** (not visible) provides service access.
9. **Top Cover** provides service access.
10. **Control Escutcheon** is removable for servicing or replacing microprocessor.
11. **Side Panels** support insulation and form outside of cabinet.
12. **Rack Support Bracket** receives rack support.
13. **Air Heaters** (not visible) supply air heat for food texture control.
14. **Door & Latch** can be reversed on site.
15. **Door Gasket** seals food chamber against heat or vapor loss.
16. **Name Plate** identifies model and serial number- important for servicing and parts orders. Plate also displays electrical data.

controls

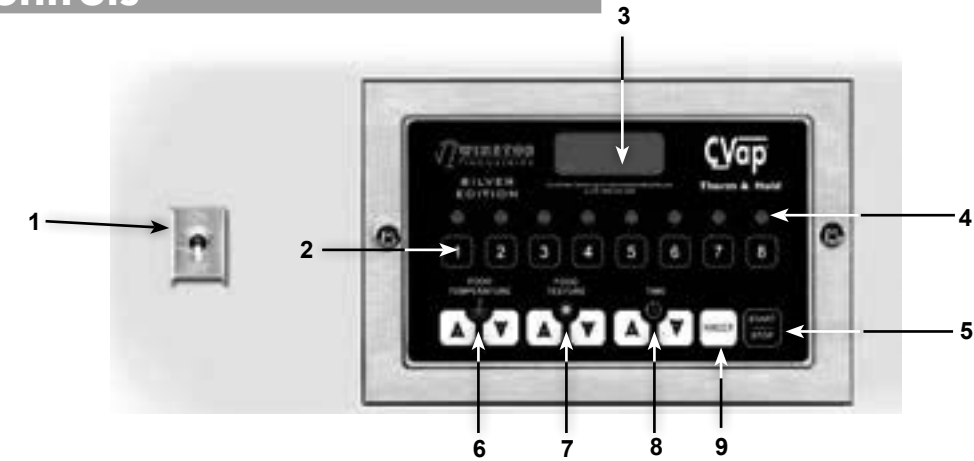

1. **Power Switch** controls electrical power to the cabinet.
2. **Mode Buttons** (cook / retherm / hold channels) provide operators with the ability to select desired mode of operation. Long press of these buttons allows operator to cancel out of a cook, retherm, or hold cycle. Buttons are numbered 1 through 8.
3. **Digital LED Readout** displays chosen setpoints for food temperature, food texture, and cook time as the cabinet is programmed. After pressing Start/Stop button, the display indicates the remaining time in each portion of the cooking process.
4. **LED Program Lamps** indicate which mode is selected when illuminated above that button.
5. **Start/Stop Button** is used to start or stop the selected mode of operation. A long press from **IDLE** allows the operator to enter programming mode.
6. **Food Temperature Up (▲) and Down (▼) Buttons**. Short press either button to adjust temperature.
7. **Food Texture Up (▲) and Down (▼) Buttons**. Short press either button to adjust the level of moistness or crispness in food.
8. **Time Up (▲) and Down (▼) Buttons**. Short press either button to adjust cook time.
9. **HACCP Button** enables user to check current HACCP-relevant conditions inside the cabinet. provides operator the ability to check current food temperature (E=evaporator), food texture (A=air), dry air (D=differential), relative humidity (H), or probe (P) at any time during the cycle (see page 10). This button provides HACCP data recall for Gold edition controls.



What's the difference between a long press and a short press?

Short Press - Press button, hold for less than 1 second.

Long Press - Press button, hold for more than 1.5 seconds.

daily operating procedure

⚠️ WARNING

Contamination Hazard

Can cause serious illness.
Clean equipment prior to first use, to remove traces of industrial chemicals and oils.

Prior to using equipment for the first time, perform the daily cleaning procedure listed on pages 18 and 19.

1. Prepare unit for cooking/ retherming/ holding. Adjust rack supports in retherming cavity if required.
2. **Fill evaporator with 3.5 gallons (13.3 liters) of water prior to operation.** We recommend filling manually at first, rather than waiting for the auto fill to fill it. **Tip:** Speed up initial cabinet preheat by using hot water (do not use water that's hotter than the desired food temperature. Locations with hard water should add one tablespoon white vinegar or lemon juice to water in evaporator to help prevent scale buildup. You may want to seek advice from your local water authority concerning possible water treatment necessary for the protection of the unit. Some water supplies are high enough in chemical content to be capable of destroying stainless steel if used untreated. The evaporation process can concentrate the chemicals to a level which causes a high interaction with stainless steel. When water is of unknown quality, automatic fill units should be connected to the water source through a deionizer/demineralizer. Experience has shown that leaks will occur by failing to clean and rinse the evaporator daily. **Leaking evaporators are not covered under warranty.**

3. Operating and Programming Functions Using Preprogrammed Settings

Preheat

- A. Turn Power Switch on. **IDLE** will display on the LED readout until operator selects mode. **Note: Unit will not preheat until program button is selected.**
- B. Select the desired preprogrammed mode (short press); Buttons 1-8 (refer to guidelines on pages 13 through 15 for suggested cook/ retherm cycles). A red light will appear above the selected button. Food temperature and food texture settings have been preprogrammed for each button 1-8 in the default mode. The operator must program a time value to initiate the timer function. 
- C. Once a button is selected, the cabinet will enter a Preheat mode and display **PRHT** on the LED display.
- D. When the cabinet reaches the selected channel's food temperature and food texture levels, the word **LOAD** will display on the LED, and a five-second alarm will sound.

Load Cabinet / Cook / Retherm Cycle

- A. Load cabinet with desired product.
- B. Check time value to ensure it is correct (see check values description). Press the time ▲ and ▼ buttons to program a cook / retherm time (refer to suggested guidelines on pages 15-17). 

- C. Long press Start/Stop button to start the timer. The programmed cook / retherm time will display with a flashing colon. Cook/retherm time cycle will then count down. 
- D. When timer reads 00:00, a five-second alarm will sound and cabinet will automatically enter hold mode (hold food temperature and food texture settings are preprogrammed at the factory for buttons 1-8 in the default mode, time is indefinite). **Hold** will display until operator cancels program. Refer to guidelines on pages 15 through 17 in the right hand column.

Hold Cycle / Unload Cabinet

- A. When the cook/retherm mode is complete, an alarm will sound, and the LED will display **HOLD** and **time value counting up**. Food will continue to hold at preprogrammed settings until Start/Stop button is pressed.  Hold is an infinite time value.
- B. Either remove food product after cook / retherm cycle is complete and alarm sounds, or allow food to hold for food production flow and flexibility. We recommend that you open the door for one to five minutes after cook/retherm cycle when selecting buttons 1 through 7. This will help prevent overcooking.
- C. Button 8 in the default mode is pre-programmed as a dedicated Hold Mode. Use this button to operate the unit as a holding cabinet. Program time value for total time needed. Note: Default setting is ten hours. You can use the Time up or down buttons to initiate a timed cycle, or as an egg timer. Time will

count down to zero, then an alarm will sound until you add time or reset cycle. To reset, depress Button 8, or other channel button. To cancel cycle, depress channel button. The Start/Stop button is non-active in this setting.

Canceling a Cycle

To cancel a cook/retherm cycle in at any point in the cycle:

- A. Long press the selected button. The red light will go off and unit will revert to **IDLE** on the LED display.
- or
- B. Long press the Start/Stop button. Unit will revert to **IDLE** on the LED display. 

ELEC Message on LED

If the LED is displaying **ELEC** it indicates there has been a power interruption. This can occur if there is an interruption to the electrical power being supplied to the equipment (a blackout), or if equipment's power switch is turned off during a cycle. To remove **ELEC** message, **long press** the Start/Stop button until the LED display reads **IDLE**. Proceed with normal application. 

⚠️ WARNING

Temperature Hazard

Can cause serious illness.
Verify that food temperature has not fallen into the danger zone.





If power is interrupted for an extended period, food temperature can drop out of the safe zone. Ensure that appropriate HACCP standards have been maintained prior to serving.



4. Programming Instructions









Winston's control enables the operator to manually program a cook or retherm cycle and hold cycle for each of the channel buttons (1–8). See description below for description of programming modes.

- E1 = Food Temperature button / Temperature of moist heat cook/retherm cycle.
- Ehold = Food Temperature button / Temperature of moist heat hold cycle.
- A1 = Food Texture button / Total oven temperature of cook retherm cycle.
- Ahold = Food texture button / Total oven temperature of hold cycle.
- T1 = Cook/retherm time
- Cnst = Infinite hold time

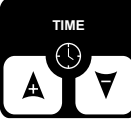

Channel Button 1	Channel Button 2	Channel Button 3	Channel Button 4	Channel Button 5	Channel Button 6	Channel Button 7	Channel Button 8
E1	E1	E1	E1	E1	E1	E1	E1
E Hold	E Hold	E Hold	E Hold	E Hold	E Hold	E Hold	E Hold
A1	A1	A1	A1	A1	A1	A1	A1
A Hold	A Hold	A Hold	A Hold	A Hold	A Hold	A Hold	A Hold
T1	T1	T1	T1	T1	T1	T1	T1
CnST	CnST	CnST	CnST	CnST	CnST	CnST	CnST

- A. Long Press the Start/Stop button. LED will display **PROG** (Program). 
- B. Short press desired channel button (1-8) to program. LED will light above chosen channel button.
- C. To program intervals **E1**, **E HOLD**: Depress the Food Temperature  buttons. **E1** will display, followed by the temperature values. Using the arrows, select desired temperature. Depress the channel button to move to Ehold interval. Depress the  and  buttons. **Ehold** will display, followed by



the temperature values. Using the  and  buttons, select desired temperature.

- D. To program intervals **A1**, **A Hold**: Depress the Food Texture  buttons. **A1** will display, followed by the temperature values. Using the  and  buttons, select desired temperature. Depress the channel button to move to A Hold interval. Depress the Food Temperature  buttons. **A HOLD** will display, followed by the temperature values. Using the  and  buttons select desired temperature.
- E. To program interval **T1**, depress the Time  buttons. **T1** will display, followed by the time values. Using the  and  buttons, select desired times. T1 is only programmed using E1 and A1.

5. Constant Cook Programming Instructions



To program the oven to continuously cook (CnST), depress the Time  or  buttons until display reads **CnST**. NOTE: When programmed, CnST will allow constant cooking or retherming and **NO HOLD** cycle. NOTE: This also activates the egg timer. To cancel cycle, depress channel button. Start/Stop button is non-functional in this mode.

6. Egg Timer Operation (only available when no hold values are selected, E Hold, A Hold)

- A. Count-down timer is independent of heat control. To set egg timer, press the Time  and  buttons.
- B. When timer reaches 00:00 value, alarm will sound. The alarm may be disarmed by a short press of the Time  button. The equipment will not enter an automatic hold.
- C. Egg timer will read **CnST** + value. To cancel cycle, depress channel button. Start/Stop button is non-functional in this mode.

7. Set Delay Timer



The delay timer enables the operator to specify an amount of time before the oven will enter preheat mode.

- A. To enter DELAY programming, while in **IDLE**, long press the Time  button.
- B. The LED display will read **dLay**.
- C. Select the channel button to cook, retherm, or hold. LED light will illuminate over the button number.
- D. Using the Time  and  buttons, program the number of hours to preheat.
- E. Short press Start/Stop button.
- F. Display will alternate between **dLay** and the amount of time remaining until preheat.

G. At the specified time, delay mode will automatically engage heaters and enter a preheat mode for selected channel.

H. Delay timer may be canceled with a long press of Start/Stop button, returning the cabinet to **IDLE** mode. 



8. To Check Cycle Settings

- A. To view current temperature, short press HACCP button. The LED will read the evaporator (**E**) temperature, differential (**D**) temperature, air (**A**) temperature, in order, displaying each reading consecutively for five seconds. 
- B. To view programming settings, depress channel button (1–8) and long press Food Temperature  button. The LED display will read the following values: **E1**, **E hold**, **A1**, **A Hold** consecutively.

Quick Operating Procedures Using Factory Preprogrammed Settings

Here are some tips for operating your CVap® therm & hold cabinet.

To select mode – Press desired channel button (1–8). Red LED lamp will light above selected channel.

To start retherm mode – When display shows **LoAd**, add food, program time (using Time  and  buttons), and then press long press Start/Stop button. 

To check temperature – Water (evaporator) temperature may be checked at any time during a cycle by pressing the HACCP button. Current water temperature will be displayed. Press the HACCP button again to display differential temperature between water and air. Press the HACCP button a third time for total water and air temperature. Press HACCP button a fourth time for HACCP food probe (if applicable). Press HACCP button a fifth time for relative humidity.



To cancel cycle – Any cycle may be cancelled by long pressing the Start/Stop button of selected mode after cycle has been started. **IdLE** will be displayed and cabinet will not heat until a mode has been selected.



For any of the following three functions, make certain the control reads “idLE.”

To change from Fahrenheit to Centigrade - Press and hold the Food Temperature ▼ button and Food Texture ▲ button at the same time, and then toggle the Food Texture ▲ button to **CENT** or **FAHR**.



To disarm low water alarm – hold down both Food Temperature ▲ and ▼ buttons and toggle.

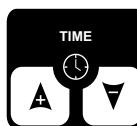

To set RTC-Clock setting – From the Idle mode, long press the Time ▲ and ▼ buttons. Toggle the Time ▲ and ▼ buttons until time displays on the control LED. Press the Time ▲ and ▼ buttons to set the time to operator's local time (the default is Eastern Time Zone). After time has been set, wait 5 seconds for the control display to revert back to display **IDLE**. Note: Time is displayed in military time.

⚠ WARNING

Temperature Hazard

Can cause serious illness. Verify that food temperature has not fallen into the danger zone.

ELEC Message on LED

If the LED is displaying **ELEC**, this indicates there has been an interruption in power to the unit. This can occur if there is an interruption to the electrical power being supplied to the equipment (a blackout), or if the equipment's power switch is turned off in the middle of a cycle. To remove **ELEC** message, **long press** the Start/Stop button until the LED display reads **IDLE**. Proceed with normal application.

If power is interrupted for an extended period, food temperature can drop out of the safe zone. Ensure that appropriate HACCP standards have been maintained prior to serving.



Thermalizer

Retherm Guidelines

	Menu	Retherm (minutes)		Hold
		Thawed	Frozen	
1 Slow Moist Cook/Retherm E 190 D 40 A 230	Wrapped sandwiches, i.e., frozen/thawed hot dogs, hamburgers, chicken. BBQ items, i.e., pulled beef pork ribs, ground meat. Vegetables, i.e., frozen, canned, fresh vacuum - packed bags/chubs. Pizza (moist, soft crust no color, combination dishes i.e. lasagna/casseroles/eggs).	25-35	30-70	Auto Soft Moist Hold Food Temp 150°F (66°C) Food Texture 160°F (71°C)
2 Moist Bake E 170 D 120 A 290	Pizza (moist with some browning), breakfast items i.e., pancake on stick, french toast, waffles, smiles, grilled cheese, hot pockets, pizza sticks, burritos, egg rolls, hashbrowns, fish patty, chicken patty, grilled proteins, biscuits, desserts, i.e., pies/rolls/bar cookies.	14-25	18-30	Auto Moist Bake Hold Food Temp 150°F (66°C) Food Texture 175°F (79°C)
3 Moist Cook/Retherm E 190 D 110 A 300	Fast bake pizza (moist with some browning), chicken patty, fish patty (whole meat product), wrapped sandwiches, i.e., frozen/thawed hot dogs, burgers, chicken BBQ items, i.e., pulled pork ribs, large proteins and combination foods, i.e., casseroles, vegetables (fresh, frozen, canned), desserts, such as, individual cookies, rolls, pies, cakes.	12-30	30-70	Auto Moist Hold Food Temp 150°F (66°C) Food Texture 160°F (71°C)
4 Crisp Bake E 150 D 200 A 350	Crisp chicken patty, fish patty, steak, popcorn/breaded foods, french fries, potato products, items typically cooked in fryer (note: items must be bakable)	12-30	12-60	Auto Crisp Hold Food Temp 140°F (60°C) Food Texture 190°F (88°C)
5 Extra Crisp Bake E 130 D 220 A 350	Bake-only fries, tater tots or extra crispy items.	12-30	12-60	Auto Crisp Hold Food Temp 130°F (54°C) Food Texture 190°F (88°C)
6 Rapid Retherm E 190 D 160 A 350	Baked potatoes, casseroles.	15-40	30-90	No Hold. Remove product when Retherm cycle is completed
7 Bake E 170 D 180 A 350	Sheet cakes/pastries, general bake cycle.	20-60	60-300	Auto Bake Hold Food Temp 150°F (66°C) Food Texture 180°F (82°C)
8 General Holding Cycle E 150 D 30 A 180	Holding of foods with moist/firm texture.	Constant		General Hold Food Temp 150°F (66°C) Food Texture 180°F (82°C)



WINSTON INDUSTRIES
THE TASTE OF INNOVATION

Copyright© 2017 Winston Industries LLC. All rights reserved. CVap is a registered trademark of Winston Industries LLC. The CVap logo is a trademark of Winston Industries LLC. All other company and product names may be trademarks of their respective companies.

Models CAT507, CAT509, CAT522, & CAT529

Retherm Guidelines

Thermalizer

- E** Moist Heat/Food Temperature
- D** Dry Heat
- A** Total Oven Temperature/Food Texture

	Menu	Retherm (minutes)		Hold
		Thawed	Frozen	
1	Slow Moist Cook/Retherm E 190 D 40 A 230			Auto Soft Moist Hold Food Temp 150°F (66°C) Food Texture 160°F (71°C)
2	Moist Bake E 170 D 120 A 290			Auto Moist Bake Hold Food Temp 150°F (66°C) Food Texture 175°F (79°C)
3	Moist Cook/Retherm E 190 D 110 A 300			Auto Moist Hold Food Temp 150°F (66°C) Food Texture 160°F (71°C)
4	Crisp Bake E 150 D 200 A 350			Auto Crisp Hold Food Temp 140°F (60°C) Food Texture 190°F (88°C)
5	Extra Crisp Bake E 130 D 220 A 350			Auto Crisp Hold Food Temp 130°F (54°C) Food Texture 190°F (88°C)
6	Rapid Retherm E 190 D 150 A 350			No Hold. Remove product when Retherm cycle is completed
7	Bake E 170 D 180 A 350			Auto Bake Hold Food Temp 150°F (66°C) Food Texture 180°F (82°C)
8	General Holding Cycle E 150 D 30 A 180			General Hold Food Temp 150°F (66°C) Food Texture 180°F (82°C)

Copyright© 2017 Winston Industries LLC. All rights reserved. CVap is a registered trademark of Winston Industries LLC. The CVap logo is a trademark of Winston Industries LLC. All other company and product names may be trademarks of their respective companies.

Roasting Guidelines

Thermalizer

Menu	Retherm		Roasting Time	Hold	
	Food Temp	Food Texture		Food Temp	Food Texture
Top & Bottom Rounds Rare	130-135°F 54-57°C	160-175°F 71-79°C	5-7 hrs. 30 minutes per lb. 66 minutes per kg.	130°F 54°C	135°F 57°C
Medium	140-145°F 60-63°C	170-175°F 77-79°C		140°F 60°C	145°F 63°C
Well-done	145-150°F 63-66°C	175-180°F 79-82°C (30° differential)		140°F 60°C	145°F 63°C
Corned Beef (requires minimum 2-hour hold)	190°F 93°C	250°F 121°C	20 minutes per lb. 44 minutes per kg.	165°F 74°C	180°F 82°C
Beef Brisket (requires minimum 2-hour hold)	190°F 88°C	220°F 104°C	20 minutes per lb. 44 minutes per kg.	165°F 74°C	180°F 82°C
Chicken Breast* 4-6 oz. (113-170g)	140-165°F 60-74°C	185-200°F 85-93°C	30-60 minutes	140°F 60°C	165°F 74°C
Whole	140-165°F 60-74°C	300-350°F 149-177°C	45-60 minutes	140°F 60°C	165°F 74°C
Turkey (25-lb (11.3-kg)), whole or breast (recommend overnight for whole)	140-165°F 60-74°C	300-350°F 149-177°C	5 hours or 12 minutes per lb. 27 minutes per kg.	140°F 60°C	165°F 74°C
Ham (football)	190°F 88°C	230-300°F 110-149°C	15 minutes per lb. 33 minutes per kg.	150°F 66°C	160°F 71°C
Pork Ribs (requires minimum 1-hour hold)	190°F 93°C	230°F 110°C	2 - 2.5 hours	140°F 60°C	165°F 74°C
Hamburger Raw	140-165°F 60-74°C	225-350°F 107-177°C	20 - 60 minutes	140°F 60°C	165°F 74°C
Fish/Seafood Filet	140-160°F 60-71°C	200-300°F 93-149°C	30 - 60 minutes	140°F 60°C	165°F 74°C

- Time and temperature settings are recommended guidelines only. Due to variations in the products' quality, weight, and desired degree of doneness, the cooking times may need to be adjusted accordingly.

daily cleaning

Required Cleaning Accessories & Supplies

- Pan for draining evaporator (unless utilizing floor drain)
- Food grade germicidal detergent
- Descaling agent

⚠️ DANGER

Electric Hazard

Can cause serious injury or death.

If an electrical shock is felt during operation or cleaning, unplug equipment and have it serviced by a licensed electrician or trained servicer before placing back into service.

⚠️ WARNING

Contamination Hazard

Can cause serious illness or damage to equipment.

Clean equipment daily to avoid potential contamination hazard.

Ensure safe operation by cleaning cabinet daily. Failure to do so can allow harmful deposits to develop, increasing the potential for food contamination, and endangering your customers.

⚠️ CAUTION

Corrosion Hazard

Can cause damage to equipment.

Clean equipment daily to avoid potential corrosion damage.

Clean evaporator daily to prevent chlorides (salts) from accumulating. Chlorides can cause the evaporator tank to corrode, to the extent that leaks can occur. Leaks caused by corrosion, which is caused by a failure to clean daily, are not covered under the manufacturer's warranty.

⚠️ WARNING

Contamination Hazard

Can cause serious illness.

Clean equipment prior to first use, to remove traces of industrial chemicals and oils.

Prior to using equipment for the first time, perform the daily cleaning procedure listed on the next page.

daily cleaning procedure

⚠️ CAUTION

Burn Hazard

Can cause injury.

Allow 30 minutes for equipment to cool before attempting to clean.

Before each cleaning procedure, disconnect equipment from its electrical power source and allow to cool for at least one half hour.

1. Place empty pan under drain valve, open valve, and allow evaporator to drain.
2. Remove and clean rack supports using a food grade germicidal agent. Clean probe (if included) with mild soap and water.
3. Spray food chamber and evaporator with a food grade germicidal detergent.
4. Wipe inside surfaces to remove all food deposits.
5. Inspect for scale build-up on tank surface, float, and probe. (see photo below). If present, apply descaling agent. Read ALL warnings and follow directions listed on descaling agent package.

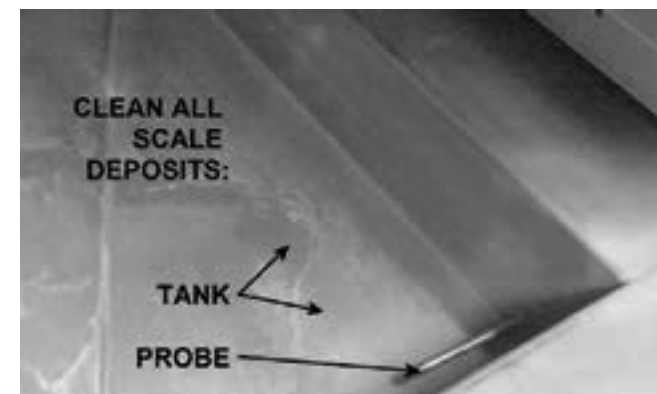

6. Inspect heating elements (if exposed). The heating elements are stainless steel. If cleaning is needed, scrub with a Teflon® or nylon bristle brush to remove heavy food particles. Further cleaning may be done with a plastic scouring pad and alkaline based cleansers. **DO NOT** use wire brushes, scrapers, steel wool pads or chloride based cleansers. Follow cleanser manufacturer's instructions for use on stainless steel. Rinse well several times with clean water and wipe immediately.
7. Rinse all inside surfaces, including evaporator, and dry with clean towel.

⚠️ WARNING

Electrical Hazard

Can cause serious personal injury or damage to equipment.

Avoid spraying equipment exterior or controls with water.

Do not spray outside of equipment or controls with water.

8. Rinse, dry, and replace rack supports.
9. Verify that valve is closed, and refill evaporator.
10. Reconnect equipment to electrical power and make ready for use.

troubleshooting

We know how frustrating and costly it can be when a critical piece of equipment is down for repairs. It is our goal to minimize service disruptions, to get you back up and operating in the shortest time possible.

We carefully analyze all service calls. This analysis helps us to improve our manufacturing processes, and reduces product service issues. Generally speaking, most equipment failures can be attributed to the following three causes:

- Faulty use and care practices.
- Electrical supply problems.
- Equipment faults.

Please refer to the Troubleshooting Chart on the page 22 for common problems and solutions. If the problem you're experiencing isn't listed, or if the standard solution fails to resolve your problem, you will need a

qualified servicer to diagnose and repair the problem.

If your equipment is still under warranty, or you are uncertain whether or not warranty is still in place, please call Winston Customer Service at 1-800-234-5286 (or 502-495-5400). Our friendly staff will help you verify coverage, and if under warranty, will arrange for a servicer to call on you.

If your equipment is no longer under warranty, or you are uncertain whether the warranty is still in place, please call Customer Service at 1-800-234-5286, or visit our website at www.winstonind.com, and click the Service tab to locate an authorized servicer near you.

In order to expedite service, please have the complete model and serial number (found on the equipment's identification tag) on hand when you contact us.

Please have the following information on hand when contacting Winston Industries regarding product service.

1. **Model** _____ **Serial #** _____
(located on name plate)
2. **Your name** _____
3. **Company name** _____
4. **Company address** _____
5. **Company phone** _____
6. **Type of problem** _____

troubleshooting

⚠ DANGER

Electrical Hazard

Can cause serious injury or death.
Do not attempt to install or service equipment unless you are a licensed electrician or trained servicer.

This equipment utilizes high voltage, high temperature heating systems, and hot water vapor. If used improperly, any of these hazards can cause serious injury or death. To avoid the potential for an accident, please have cabinet installed by a licensed electrician, and serviced only by trained servicers. Please make these pages available to the servicer.

SERVICE PARTS	PART NUMBER	SERVICE PARTS	PART NUMBER
Ball Valve 1/4", for transport cabinets	PS2896	Heater Water 240V (1852 watts, 31.1 ohms)	PS2795
Bracket Mount Threaded Caster Holds Stem Caster New Style after 20060123-029	PS2934-4	Heater Air 208V (29) (2800 watts, 15.5 ohms)	PS2732
Bracket Mount Threaded Caster Holds Stem Caster Old Style before 20060123-029	PS2421-4	Mobile Water Removal Motor, Blower Motor, Blower (Before November 2004)	PS2696 PS2119 PS2100
Caster, 5" Locking	PS2142	Motor Cooling	PS2098
Casters, 5" Non-Locking	PS2141	O-Ring for Drain Cap	PS1280-3
Caster, 5" Lock & NLock Stem (29)	PS2343-4	O-Ring for Float	PS1216-1
Caster, 3" locking	PS2146	O-Ring for Heaters	PS1784-3
Caster, Swivel, non-lock, 3 T-Stem	PS2147	O-Ring for Water Inlet	PS1786-3
Casters 3" Non-Locking	PS2540-4	Power Cord	PS2346
Casters 3" Plate Locking	PS2310	Power Switch	PS2304
Casters 3" Plate Non-Locking	PS2311	Probe, Air	PS2178
Control Board 208/240V	PS2613	Probe, Water	PS2177
Control Board 208/240V, Stargazer	PS2964	T-Stat Hi Limit	PS2750
Door handle, magnetic	PS1774	Rails, Wire	PS2359
Door Hinge	PS2116	Rails, Wire, (26 pack)	PS2359-26
Door Relay Switch 3.62 Ohms	PS2991	Relay 208/240 Three pole Main & Air Relay	PS1007
Door Switch Stop Asm	PS2372	Relay 208/240 Two pole Water heater Relay	PS2460
Fan Blade	PS2371	ScaleKleen (24 pack)	PS2192-24
Floats	PS2669	ScaleKleen (12 pack)	PS2192-12
Floats SS	PS2669 SS	Top Cover Extension 11" (22)	PS2351
Evaporator Cover	PS1806	Top Cover Extension 8.5" (22)	PS2553
External Water Filter	PS2429	T-Stat HI Limit	PS2750
Gasket, door (Top) (22)	PS2798	Tube & Clamps	PS2586
Gasket, door, bottom (22)	PS2799	Valve Saddle, Self Tapping	PS1251
Gasket (29-BD)	PS2796	Valve Water Retro Upgrade from Plastic to Brass	PS2692
Gasket, door, bottom	PS2150	Water Solenoid (208V)	PS2754
Gasket, door, top	PS2151	Wheel Stems (29)	PS2540-4
Grommet, Large, door (6 pack)	PS1263-6	Water Solenoid/Valve (Brass) 208/240V	PS2754
Grommet, Small, (6 pack)	PS1271-6	Wire Oven Rack, Chrome Plated	PS2206-14
Handle-Magnetic	PS1774	Wire Oven Rack, Chrome Plated	PS2206-4
Heater Air 208V, 3 Phase (3004 watts, 14.4 Ohms)	PS2766	Wire Oven Rack, Chrome Plated	PS2206-6
Heater, Air 240V (1852 watts, 31.1 ohms)	PS2714	Wire Rail, Chrome Plated	PS2980-1
Heater, Water 208V (1803 watts, 24 ohms)	PS2174	Wire Rail, Chrome Plated 26-pack	PS2980-28

troubleshooting

TROUBLE	FAULT CODE
Digital display fails to light.....	A
Flooding/leaking water	G, H
Food drying out	B, D, E, G
Food excessively moist	C, F
Food not hot enough.....	B, D, F, G
Food too hot	C, E
Injury or accident.....	I

FAULT	CORRECTION
A. Circuit breaker tripped.....	Adjust
Fuse blown.....	Replace
Power cord not plugged in.....	Adjust
Faulty cordset	Call servicer
Faulty power switch	Call servicer
B. Evaporator (water) tank empty	Adjust, see pg. 10
C. Food Temperature setting too high	Adjust, see pgs. 10-12
D. Food Temperature setting too low	Adjust, see pgs. 10-12
E. Food Texture setting too high	Adjust, see pgs. 10-12
F. Food Texture setting too low.....	Adjust, see pgs. 10-12
G. Door gasket defective	Replace
H. Drain valve defective or missing.....	Replace
I. Injury or accident - call manufacturer	Tel 1-800-234-5286

Warranty and Terms and Conditions

Limited 1 year Warranty (excluding gaskets, lamps, hoses, power cords, glass panels, fryer baskets, batteries, and evaporators). Warranty disclaimer for failure to clean.

WINSTON EXPRESSLY DISCLAIMS ALL OTHER WARRANTIES, EITHER EXPRESS OR IMPLIED, INCLUDING ANY IMPLIED WARRANTY OF FITNESS FOR A PARTICULAR PURPOSE AND ANY IMPLIED WARRANTY OF MERCHANTABILITY.

For complete details on warranty and terms & conditions of sale, go to:

<https://foodservice.winstonind.com/warranty-information/>

Both the Warranty and Terms and Conditions of Sale are integral to this document.

Need Parts?

For more information regarding genuine Winston replacement parts and accessories visit our website.

OEM parts are designed specifically for our products, and can help you save on costly repairs. Protect your warranty coverage with genuine Winston parts. <https://foodservice.winstonind.com/parts-supplies>