

Series Includes:
HBK5D1



WELCOME

If you have questions about your CVap equipment, please contact your corporate office, local distributor, or Winston's Customer Care Center via the contact info below.

CONTACT INFORMATION:

www.winstonfoodservice.com
 E-mail: customercare@winstonind.com
 Phone: 1.800.234.5286 | 1.502.495.5400
 Fax: 1.502.495.5458
 Mail: 2345 Carton Drive | Louisville, KY 40299 USA

CONTENTS

Important Safety Information	2-3
General Installation	3-4
How Your CVap Works	5
Daily Cleaning Procedure	6-7
Warranty & Terms and Conditions	8

WARNINGS AND INSTALLATION INSTRUCTIONS

As is the case with most cooking equipment, your CVap hold & serve drawer should be used with caution. Please read the following warnings to avoid potential injuries.

! DANGER: Electrical Hazard

Can cause serious injury or death >> Do not attempt to service this equipment unless you are a licensed electrician or trained servicer.

Because this equipment utilizes high voltage, it should only be installed and serviced by a licensed electrician or trained servicer. Attempting to install or service the equipment yourself could result in serious, potentially fatal injuries.

If an electrical shock is felt when touching equipment, shut off power immediately (pull cord or turn off circuit breaker) and call a trained servicer for repair. Failure to do so could result in serious, potentially fatal injuries.

Always turn power switch off any time equipment is not in use.

! WARNING: Burn Hazard

Can cause serious injury >> Avoid heated vapor when opening or closing cabinet door.

This equipment utilizes heated water vapor, which transfers heat much more quickly and efficiently than dry air of the same temperature. Use caution when opening drawers or reaching into the equipment, as heated vapor can quickly cause burns.

! WARNING: Contamination Hazard

Can cause serious illness or damage to equipment >> Clean equipment daily to avoid potential contamination hazard.

Clean equipment daily to prevent buildup of food residue or chlorides, which can also damage stainless steel and contaminate food. Failure to follow proper cleaning procedures can void your warranty.

Prior to using equipment for the first time, perform the daily cleaning procedure listed on pages 6-7.

! CAUTION: Electrical Hazard

Can cause injury >> Do not connect equipment to an external switching device.

In order to avoid a hazard due to inadvertent resetting of the thermal cutout, this equipment must not be supplied through an external switching device, such as a timer, or connected to a circuit that is regularly switched on and off by the utility.

! CAUTION: Burn Hazard

Can cause injury >> Allow 30 minutes for equipment to cool before attempting to clean.

Always allow equipment to cool before cleaning to avoid potential burns.

! WARNING: Safety Hazard, Intended Use

Can cause serious injury or damage to equipment >> Supervise untrained, young, or handicapped persons.

1. This equipment is not intended for use by persons (including children) with reduced physical, sensory, or mental capabilities, or lack of experience and knowledge, unless they have been given supervision or instruction concerning use of the equipment by a person responsible for their safety.
2. Children should be supervised to ensure that they do not play with the equipment.
3. This equipment is intended to for commercial applications, such as restaurants and institutions, and in commercial enterprises such as bakeries, but not for continuous mass production of food.

! CAUTION: High Temperature & Grease Hazard

Can cause damage to equipment >> Avoid placing equipment near high heat or in grease-laden atmosphere.

Do not place equipment in areas where air temperature exceeds 100°F (38°C). A heat shield may be required to prevent heat exposure and grease-laden vapors from affecting the equipment if near heat, vapor, or grease generating devices (such as grills, steamers, ovens, etc.). Excess heat and grease inside the equipment cavities may cause electrical components to fail.

WATER FILL PROCEDURE

Water Supply

In order to operate properly, the evaporator in this cabinet must be filled with clean, potable water. As water evaporates, any minerals in the water will deposit on the surface of the evaporator. These mineral deposits will inhibit the transfer of heat. Deposits can also degrade and damage stainless steel. The best way to avoid mineral deposits is to clean the equipment daily. It is also advisable to contact your water utility for advice on minimizing deposit buildup.

For locations with hard water, add one tablespoon (15ml) of white vinegar or lemon juice to water to help

minimize scale buildup. Please consider contacting your local water authority to obtain advice on possible water treatment to protect the equipment. Some water supplies are high enough in chemical content to be capable of damaging stainless steel (if used untreated). The evaporation process can concentrate the chemicals in the water to a level which could cause a damaging reaction with the stainless steel.

INSTALLING AUTO WATER FILL

Insert tubing and push fully into the connector (reference drawing below). Once seated, try to pull the tubing out of the connector so that the capture ring comes out (about 1/16" (1.6mm)) and the tubing cannot be removed.

Prior to connecting a newly installed water line to the auto water fill connection, it is extremely important to flush the water line of any debris. Debris in the water line will cause damage to the water solenoid and would not be covered under warranty.

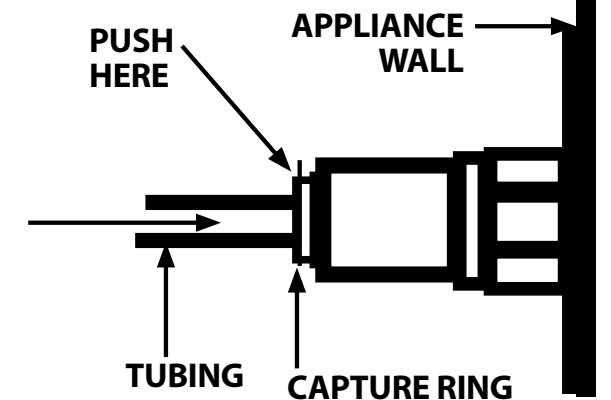

The maximum incoming water temperature may not exceed 140°F (60°C) and the incoming water pressure must be between 20 and 150 psi (1.4 Kgf/cm2 to 10.5 Kgf/cm2 (kilogram-force per sq. centimeter)).

! CAUTION: High Temperature Hazard

Can cause damage to equipment >> Fill evaporator with water prior to turning power on, and do not allow evaporator to run dry.

CAUTION: Equipment with auto water fill systems MUST NOT BE ALLOWED TO RUN DRY. Heat damage to the water valve may result.

It is the responsibility of the owner and installer to make sure that installation complies with all applicable local and state plumbing codes.

ELECTRICAL

The equipment is shipped from the factory with a 84" (2134mm) (minimum) power cord and plug. It may be necessary to hire a licensed electrician to install the correct outlet or wiring. Winston does not recommend wiring the unit direct.

VENTILATION REQUIREMENTS

Ventilation clearances - To operate properly, the equipment will need sufficient space for air circulation. Allow at least 2" (51mm) clearance on all sides of the equipment, particularly around ventilation holes. Care should be taken to prevent placing the unit close to anything combustible. It must be installed with its supplied legs or feet. Equipment may be stacked upon each other using only a Winston supplied stacking kit and following the instructions enclosed with the kit. Your warranty may be void if you do not adhere to these ventilation requirements.

COMPONENT IDENTIFICATION



1. **Drawer** - 6" (152 mm) deep for holding one full size, two half size, or three third size pans.
2. **Name Plate** (not visible in photo) identifies model number and serial number (important for servicing and ordering parts), voltage, power, and electrical information. Electrical Requirements Label identifies that equipment is for use with an individual branch circuit only.
3. **Food chamber** - (not visible in photo) holding cavity where the dual heat system combines to create the perfect holding environment.

CAUTION: High Temperature & Grease Hazard Can cause damage to equipment >> Avoid placing equipment near high heat or in grease-laden atmosphere.

Do not place equipment in an area where air temperatures around the equipment exceed 100°F (38°C). A heat shield may be required to prevent excessive heat exposure and grease laden vapors from affecting the equipment if adjacent to heat, vapor, or grease generating devices (such as grills, steamers, ovens, etc.). Excess heat and grease inside the equipment cavities may cause electrical components to fail.

Vent hood - Generally this equipment does not need to be installed under a mechanical ventilation system (vent hood). Check local health and fire codes for specific requirements.

4. **Air Heaters** - (not visible) located inside the base, supply heat for precise food texture control.
5. **Drain Valve** - allows for draining water from evaporator.
6. **Access Panel** - (not visible in photo) provides easy access for service.
7. **Drawer Gasket** - seals food chamber against heat or vapor loss.
8. **Evaporator** - (not visible in photo) located inside the base, supplies vapor to food chamber to control food temperature.
9. **NEMA 5-15P Plug (US) and Power Cord** - (not visible in photo) located on back side, lower-right-hand corner, provides electricity to equipment. 5-20P plugs available for Canadian customers.
10. **Control panel** - contains power switch and control escutcheon. Allows operator to program food temperature and food texture. Escutcheon is removable for servicing or replacing microprocessor.
11. **Bottom Cover** - (not visible in photo) located underneath, allows service access.

CONTROLS - HBK SERIES

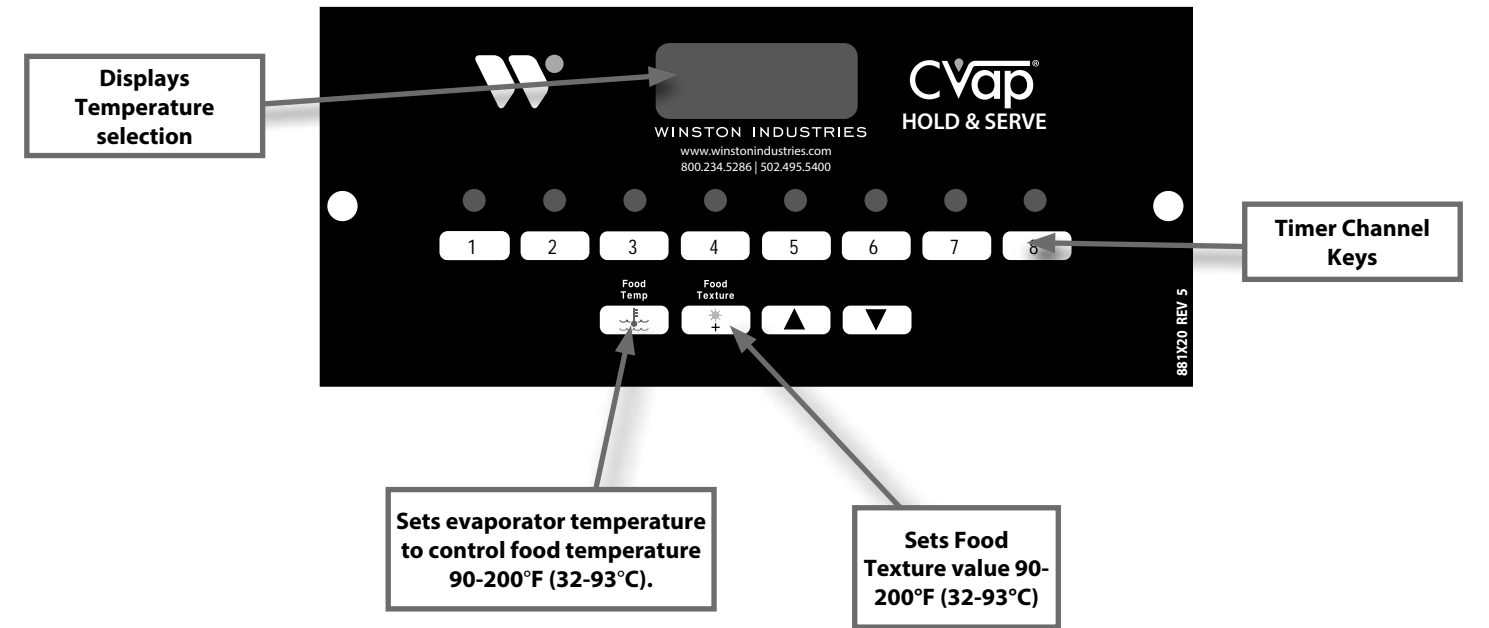

HOW YOUR CVAP WORKS

ON/OFF SWITCH	Energizes control and evaporator and air heat systems. Fill with potable water prior to turning on.
FOOD TEMP	Adjust Food Temp keys to increase/decrease temperature in 2° increments.
FOOD TEXTURE	Adjust Food Texture keys to increase/decrease the differential (temperature increase above food temp setting) in 2° increments.
CONVERT °F to °C or °C to °F	°F/°C key is unmarked - located directly beneath Channel 1 button. Unmarked key- directly below Channel 1 button. While in the programming mode, press unmarked key to switch between Fahrenheit and Celsius.
CLEAN DAILY	Stainless steel can corrode if soil is allowed to stand. Clean daily. Remove loose parts and wash in sink. Rinse well. Do not use chlorine.
CABINET RESET BUTTON (INTERNATIONAL UNITS ONLY)	(Located on the back of the unit near the top) Resets the thermostat in the event that the High Limit Thermostat trips. To reset, allow the cabinet unit to cool to below 250°F (121°C). Press the High Limit Reset button. If the High Limit Thermostat trips frequently, call a service technician for repair.
TECHNICAL SERVICE AND TROUBLESHOOTING	If you have questions about your CVap equipment, please contact your corporate office, local distributor, or Winston's Customer Care Center. web: winstonfoodservice.com e-mail: customer@winstonind.com telephone: 1.800.234.5286 +1.502.495.5400 (8:00 a.m. - 5:00 p.m. EST, Monday through Friday)

DAILY CLEANING

Required Cleaning Accessories and Supplies

- Pan for draining evaporator (unless utilizing floor drain)
- Food grade germicidal detergent
- Descaling agent

! DANGER: Electrical Hazard

Can cause serious injury or death >> If an electrical shock is felt during operation or cleaning, unplug equipment and have it serviced by a licensed electrician or trained servicer before placing back into service.

! WARNING: Contamination Hazard

Can cause serious illness or damage to equipment >> Clean equipment daily to avoid potential contamination hazard.

Ensure safe operation by cleaning equipment daily. Failure to do so can allow harmful deposits to develop, increasing the potential for food contamination, and endangering your customers.

! CAUTION: Corrosion Hazard

Can cause damage to equipment >> Clean equipment daily to avoid potential corrosion damage.

Clean evaporator daily to prevent chlorides (salts) from accumulating. Chlorides can cause the evaporator tank to corrode, to the extent that leaks can occur. Leaks caused by corrosion, which is caused by a failure to clean daily, are not covered under the manufacturer's warranty.

! WARNING: Contamination Hazard

Can cause serious illness >> Clean equipment prior to first use to remove traces of industrial chemicals and oils.

Prior to using equipment for the first time, perform the daily cleaning procedure listed in right column.

DAILY CLEANING DAILY CLEANING PROCEDURE

! CAUTION: Burn Hazard

Can cause injury >> Allow 30 minutes for equipment to cool before attempting to clean.

Before each cleaning procedure, disconnect equipment from its electrical power source and allow to cool for at least one half hour.

1. Place empty pan under drain valve, turn drain valve and allow evaporator to drain.
2. Remove drawer and wash, using a food-grade germicidal agent. Rinse and allow to dry.
3. Apply food grade germicidal detergent to food chamber and evaporator.

NOTE: To ensure that the drawer opens and closes easily, check the drawer rollers (both on the drawer and inside the equipment cavity) to make sure they are fastened tightly, in good operating condition, and not excessively worn.

4. Wipe inside surfaces to remove all food deposits.
5. Inspect for scale build-up on the tank surface, water level sensor, fill tube and probe (see photo below). If present, apply descaling agent. Read ALL warnings and follow directions listed on descaling agent package.



6. Wipe down all outside surfaces with mild detergent, in particular where the door seals. Also clean the gasket. This procedure will prolong gasket life.

! CAUTION: Leaking Hazard

Can cause damage to equipment >> Use care when cleaning plastic tube. Damage to tube can cause leaking inside the equipment.

7. Inspect heating elements (if exposed). The elements are stainless steel. If cleaning is needed, scrub with Teflon™ or nylon bristle brush to remove heavy food particles. Further cleaning may be done with a plastic scouring pad and alkaline based cleansers. DO NOT use wire brushes, scrapers, steel wool pads or chloride-based cleansers. Follow cleanser manufacturer's instructions for use on stainless steel. Rinse well with clean water and wipe immediately.

! WARNING: Electrical Hazard

Can cause serious personal injury or damage to equipment >> Avoid spraying equipment exterior or controls with water jet.

8. Rinse all inside surfaces, including evaporator, and dry with clean towel. **Do not spray outside of equipment or controls with water.**
9. Replace drawer.
10. Close drain valve and refill evaporator.
11. Reconnect equipment to electrical power and make ready for use.

HBK PROGRAMMING

COMPUTER DISPLAY	PRESS KEY/ACTION	NOTES
<p>STEP 1</p>		<p>Press and hold the #1 key while turning on the power switch. IMMEDIATELY RELEASE #1 KEY after turning on the power. The first two digits of the display will flash, indicating you are in the programming mode.</p>
<p>STEP 2</p>		<p>Select the channel you would like to program (channel 3 is selected in the following examples).</p>
<p>STEP 3</p>		<p>Use arrow keys to adjust the hold timer. Maximum is 60 minutes.</p>
<p>STEP 4</p>		<p>Press the Food Temp key to program food temperature.</p>
<p>STEP 5</p>		<p>Use arrow keys to adjust Food Temperature setting. Hold either key down for fast scrolling (off, 100 to 210°F (off, 32 to 99°C)).</p>
<p>STEP 6</p>		<p>Press Food Texture key to program food texture.</p>
<p>STEP 7</p>		<p>Use arrow keys to adjust the Food Texture setting. Hold either key down for fast scrolling (0 to 210°F (32 to 99°C)). 300°F (149°C) maximum when added to Food Temp setting.</p>
<p>STEP 8</p>		<p>To exit programming, press and hold the #1 channel key for 3 seconds until the software ID# and JF00 appear. The cabinet will then start heating to the set temperature.</p>
<p>STEP 9</p>		<p>Programming is complete.</p>

TO SET DIFFERENT HOLDING TIMES for each of the other 7 channels, repeat steps 2 and 3, then skip to step 8.

OTHER PROGRAMMING FEATURES

REBOOT PROCEDURE

On rare occasions, a power interruption may occur, making it necessary to reboot the controller software. To reboot, leave power cord on, and unplug drawer from power receptacle. Press and hold the #8 channel key while plugging the unit back in. Drawer will reboot to original factory settings.

NOTE: If location experiences frequent power interruptions, use of a surge protector is recommended.

CHANGING FROM FAHRENHEIT TO CELSIUS

Press the #1 key while turning on the power switch, then release. Locate the #9 key (hidden- directly below the #1 key) and press to switch from Celsius to Fahrenheit or Fahrenheit to Celsius. LED display will indicate which scale is active.

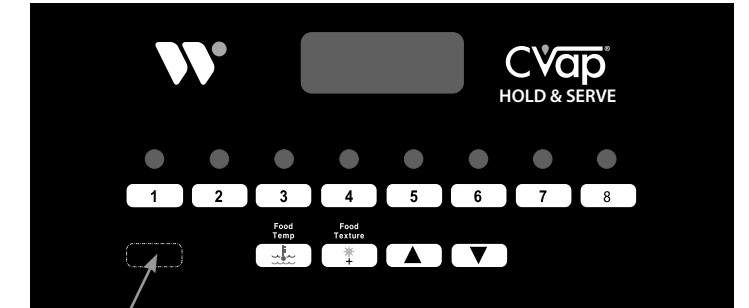

Key 9 (hidden)

WARRANTY AND TERMS & CONDITIONS

Limited 1 year Warranty (excluding gaskets, lamps, hoses, power cords, glass panels, fryer baskets, batteries, and evaporators). Warranty disclaimer for failure to clean.

WINSTON EXPRESSLY DISCLAIMS ALL OTHER WARRANTIES, EITHER EXPRESS OR IMPLIED, INCLUDING ANY IMPLIED WARRANTY OF FITNESS FOR A PARTICULAR PURPOSE AND ANY IMPLIED WARRANTY OF MERCHANTABILITY.

For complete details on warranty and terms & conditions of sale, go to:

<https://foodservice.winstonind.com/warranty-information/>

Both the Warranty and Terms and Conditions of Sale are integral to this document.

Need Parts?

For more information regarding genuine Winston replacement parts and accessories visit our website.

OEM parts are designed specifically for our products, and can help you save on costly repairs. Protect your warranty coverage with genuine Winston parts. <https://foodservice.winstonind.com/parts-supplies>



Winston Foodservice is a Division of Winston Industries LLC

2345 Carton Drive | Louisville, KY 40299

800.234.5286 | +1.502.495.5400 | Fax +1.502.495.5458 | www.winstonfoodservice.com

Revised 01.09.20